

# Operator's Manual

## Trench Roller RT 82 SC-2 RTx SC-2



EN

5200008726	04	0613
------------	----	------



**Copyright notice**

© Copyright 2013 by Wacker Neuson Production Americas LLC  
All rights, including copying and distribution rights, are reserved.  
This publication may be photocopied by the original purchaser of the machine. Any other type of reproduction is prohibited without express written permission from Wacker Neuson Production Americas LLC.  
Any type of reproduction or distribution not authorized by Wacker Neuson Production Americas LLC represents an infringement of valid copyrights. Violators will be prosecuted.

---

**Trademarks**

All trademarks referenced in this manual are the property of their respective owners.

---

**Manufacturer**

Wacker Neuson Production Americas LLC  
N92W15000 Anthony Avenue  
Menomonee Falls, WI 53051 U.S.A.  
Tel: (262) 255-0500 · Fax: (262) 255-0550 · Tel: (800) 770-0957  
[www.wackerneuson.com](http://www.wackerneuson.com)

---

**Original instructions**

This Operator's Manual presents the original instructions. The original language of this Operator's Manual is American English.

---

Foreword

SAVE THESE INSTRUCTIONS—This manual contains important instructions for the machine models below. These instructions have been written expressly by Wacker Neuson Production Americas LLC and must be followed during installation, operation, and maintenance of the machines.

Machines covered in this manual

Machine	Item Number
RT 82 SC-2	0620293
	0620367
	0620525
	0620528
	0620529
	0620530
	0620845
	5200003107
RTx	5200008538
	5200008539
	5200008540

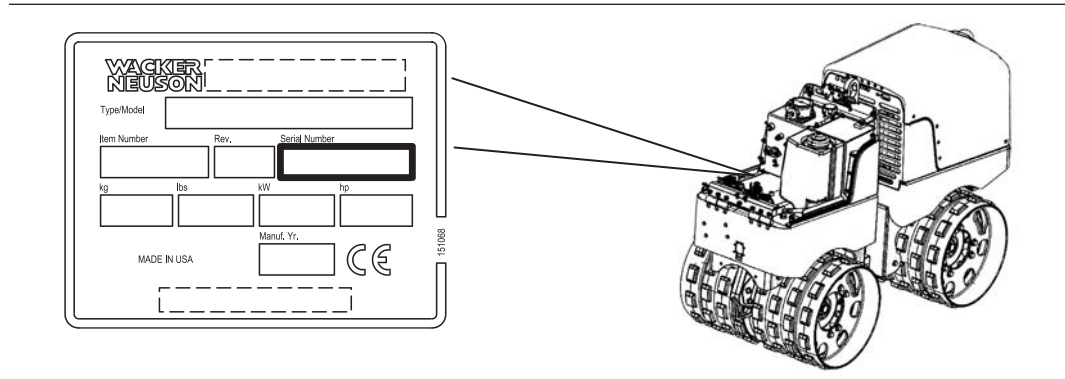

wc\_gr009903

Machine identification

A nameplate listing the model number, item number, revision number, and serial number is attached to this machine. The location of the nameplate is shown above.

Serial number (S/N)

For future reference, record the serial number in the space provided below. You will need the serial number when requesting parts or service for this machine.

Serial Number:

**Machine documentation**

- From this point forward in this documentation, Wacker Neuson Production Americas LLC will be referred to as Wacker Neuson.
- Keep a copy of the Operator's Manual with the machine at all times.
- Use the separate Parts Book supplied with the machine to order replacement parts.
- Refer to the separate Repair Manual for detailed instructions on servicing and repairing the machine.
- If you are missing any of these documents, please contact Wacker Neuson to order a replacement or visit [www.wackerneuson.com](http://www.wackerneuson.com).
- When ordering parts or requesting service information, be prepared to provide the machine model number, item number, revision number, and serial number.

**Expectations for information in this manual**

- This manual provides information and procedures to safely operate and maintain the above Wacker Neuson model(s). For your own safety and to reduce the risk of injury, carefully read, understand, and observe all instructions described in this manual.
- Wacker Neuson expressly reserves the right to make technical modifications, even without notice, which improve the performance or safety standards of its machines.
- The information contained in this manual is based on machines manufactured up until the time of publication. Wacker Neuson reserves the right to change any portion of this information without notice.
- The illustrations, parts, and procedures in this manual refer to Wacker Neuson factory-installed components. Your machine may vary depending on the requirements of your specific region.

**CALIFORNIA Proposition 65 Warning**

---

Combustion exhaust, some of its constituents, and certain vehicle components contain or emit chemicals known to the State of California to cause cancer and birth defects or other reproductive harm.

---

**Laws pertaining to spark arresters**

**NOTICE:** State Health Safety Codes and Public Resources Codes specify that in certain locations spark arresters be used on internal combustion engines that use hydrocarbon fuels. A spark arrester is a device designed to prevent accidental discharge of sparks or flames from the engine exhaust. Spark arresters are qualified and rated by the United States Forest Service for this purpose. In order to comply with local laws regarding spark arresters, consult the engine distributor or the local Health and Safety Administrator.

**Manufacturer's approval**

This manual contains references to *approved* parts, attachments, and modifications. The following definitions apply:

- **Approved parts or attachments** are those either manufactured or provided by Wacker Neuson.
- **Approved modifications** are those performed by an authorized Wacker Neuson service center according to written instructions published by Wacker Neuson.
- **Unapproved parts, attachments, and modifications** are those that do not meet the approved criteria.

Unapproved parts, attachments, or modifications may have the following consequences:

- Serious injury hazards to the operator and persons in the work area
- Permanent damage to the machine which will not be covered under warranty

Contact your Wacker Neuson dealer immediately if you have questions about approved or unapproved parts, attachments, or modifications.





## EC Declaration of Conformity

### Manufacturer

Wacker Neuson Production Americas LLC, N92W15000 Anthony Avenue,  
Menomonee Falls, Wisconsin USA

### Product

Product	RT 56-SC2, RT 82-SC2, RTx
Product category	Trench Roller
Product function	To compact soil
Item number	0620528, 0620529, 0620530, 0620845, 5200003107, 5200008540
Net installed power	15.5 kW
Measured sound power level	108 dB(A)
Guaranteed sound power level	109 dB(A)

### Conformity Assessment Procedure

According to ANNEX VIII

### Notified Body

Lloyds Register Quality Assurance Limited (Notified Body No 0088)  
71 Fenchurch Street, London EC3M 4BS, United Kingdom

### Directives and Standards

We hereby declare that this product meets and complies with the relevant regulations and requirements of the following directives and standards:

2006/42/EC, 2000/14/EC, 2004/108/EC, EN 500-1, EN 500-4

### Authorized Person for Technical Documents

Axel Häret, Wacker Neuson Produktion GmbH & Co. KG, Preußenstraße 41, 80809 München

Menomonee Falls, WI, USA, 22.02.13

William Lahner  
Managing Director

Dan Domanski  
Technical Director

Paul Sina  
Manager, Product Engineering





<b>Foreword</b>	<b>3</b>
<b>EC Declaration of Conformity</b>	<b>7</b>
<b>1 Safety Information</b>	<b>13</b>
1.1 Signal Words Used in this Manual .....	13
1.2 Machine Description and Intended Use .....	14
1.3 Safety Guidelines for Operating the Machine .....	15
1.4 Service Safety .....	17
1.5 Safety Guidelines for Lifting the Machine .....	18
1.6 Hydraulic Fluid Safety .....	19
1.7 Operator Safety while Using Internal Combustion Engines .....	20
<b>2 Labels</b>	<b>21</b>
2.1 Label Locations .....	21
2.2 Label Meanings .....	22
<b>3 Lifting and Transporting</b>	<b>29</b>
3.1 Lifting the Machine .....	29
3.2 Transporting the Machine .....	29
<b>4 Operation</b>	<b>31</b>
4.1 Preparing the Machine for First Use .....	31
4.2 Control / Component Locations .....	32
4.3 Control / Component Descriptions .....	33
4.4 Features and Controls .....	36
4.5 Accessing the Engine or Hydraulic Component Compartments .....	37
4.6 Accessing the Control Compartment .....	38
4.7 Control Panel .....	39
4.8 SmartControl™ SC-2 Transmitter .....	41
4.9 Operating Status Indicator Codes .....	43
4.10 Infra-red System and Control Channels .....	44
4.11 Before Starting .....	46
4.12 Starting .....	47
4.13 Stopping .....	48
4.14 Light Ring Color Codes .....	49
4.15 Operation .....	50

4.16 Position of the Operator .....51

4.17 Range Limits .....52

4.18 Operating Characteristics .....53

4.19 Communication Faults .....53

4.20 NiMH Battery .....54

4.21 Replacing the Battery Pack .....54

4.22 Charging the Transmitter Battery .....55

4.23 Machine Stability .....56

4.24 Articulated Joint Locking Bar .....58

4.25 Tip-Overs .....58

4.26 Emergency Shutdown Procedure .....59

4.27 Overview of the ECM and the Diagnostic Tool .....59

4.28 ECM Stages of Engine Start Up .....60

4.29 ECM Monitoring of Solenoids .....61

4.30 Connecting the Diagnostic Tool .....62

4.31 Programming the ECM Tip-Over Mode .....63

4.32 Entering the ECM Diagnostic Mode .....64

4.33 ECM Fault and Error Codes .....65

4.34 Resetting the ECM Diagnostic Data and the Tip-Over Light .....67

4.35 Calibrating the Joysticks .....68

**5 Changing Drums (RTx) 70**

5.1 Removing the Drum Extensions .....70

5.2 Installing Drum Extensions .....72

**6 Maintenance 75**

6.1 Break-in Period .....75

6.2 Periodic Maintenance Schedule .....75

6.3 Hydraulic Oil Requirements .....76

6.4 Hydraulic Oil Level .....77

6.5 Changing Hydraulic Oil and Filter .....77

6.6 Articulated Joint and Steering Cylinders .....79

6.7 Cleaning SmartControl™ Transmitter .....79

6.8 Scraper Bars .....80

6.9 Shock Mounts .....81

6.10 Battery .....81

6.11 Lubrication .....82

6.12 Engine Oil and Filter .....82

6.13 Servicing the Air Cleaner .....83

6.14 Engine Fuel Delivery System Maintenance .....85

6.15	Maintaining the Fuel Filter .....	85
6.16	Draining the Fuel Filter Water Separator .....	86
6.17	Priming the Fuel System .....	86
6.18	Engine Coolant .....	86
6.19	Adjusting Valve Clearance .....	87
6.20	Adjusting the Fan Belt .....	88
6.21	Storage .....	89
6.22	Long-Term Storage .....	89
6.23	Machine Disposal / Decommissioning .....	90
<b>7</b>	<b>Troubleshooting</b>	<b>91</b>
<b>8</b>	<b>Technical Data</b>	<b>94</b>
8.1	Engine .....	94
8.2	Roller .....	95
8.3	Lubrication .....	95
8.4	Sound and Vibration Specifications .....	96
8.5	Dimensions .....	96
8.6	Radiation Compliance .....	96
<b>9</b>	<b>AEM Safety Manual</b>	<b>97</b>
<b>10</b>	<b>Schematics</b>	<b>124</b>
10.1	Electrical Schematic - Sheet 1 .....	124
10.2	Electrical Schematic - Sheet 2 .....	125
10.3	Components .....	126
10.4	Hydraulic Schematic .....	130
10.5	Hydraulic Schematic Components .....	131



## 1 Safety Information

### 1.1 Signal Words Used in this Manual

This manual contains DANGER, WARNING, CAUTION, *NOTICE*, and NOTE signal words which must be followed to reduce the possibility of personal injury, damage to the equipment, or improper service.



---

This is the safety alert symbol. It is used to alert you to potential personal hazards.  
▶ Obey all safety messages that follow this symbol.

---



---

#### **DANGER**

DANGER indicates a hazardous situation which, if not avoided, will result in death or serious injury.

- ▶ To avoid death or serious injury from this type of hazard, obey all safety messages that follow this signal word.
- 



---

#### **WARNING**

WARNING indicates a hazardous situation which, if not avoided, could result in death or serious injury.

- ▶ To avoid possible death or serious injury from this type of hazard, obey all safety messages that follow this signal word.
- 



---

#### **CAUTION**

CAUTION indicates a hazardous situation which, if not avoided, could result in minor or moderate injury.

- ▶ To avoid possible minor or moderate injury from this type of hazard, obey all safety messages that follow this signal word.
- 

**NOTICE:** Used without the safety alert symbol, NOTICE indicates a situation which, if not avoided, could result in property damage.

**Note:** A Note contains additional information important to a procedure.

## 1.2 Machine Description and Intended Use

This machine is a remote-controlled trench roller. The Wacker Neuson Trench Roller consists of two distinct machine halves (front and rear) joined by an articulated joint. Each machine half includes an exciter assembly and two drums. The front half also includes a diesel engine and pumps for the hydraulic system. The rear half includes the hydraulic oil reservoir and the fuel tank. The diesel engine powers the hydraulic systems that provide machine movement and drum vibration. The operator controls all machine functions (steering, vibration, and engine start/stop) using an infra-red control system.

---

This machine is intended to be used for compacting sub-bases, backfill, and cohesive type soils.

---

This machine has been designed and built strictly for the intended use(s) described above. Using the machine for any other purpose could permanently damage the machine or seriously injure the operator or other persons in the area. Machine damage caused by misuse is not covered under warranty.

The following are some examples of misuse:

- Using the machine as a ladder, support, or work surface
  - Using the machine to carry or transport passengers or equipment
  - Using the machine to tow other machines
  - Operating the machine outside of factory specifications
  - Operating the machine in a manner inconsistent with all warnings found on the machine and in the Operator's Manual
- 

This machine has been designed and built in accordance with the latest global safety standards. It has been carefully engineered to eliminate hazards as far as practicable and to increase operator safety through protective guards and labeling. However, some risks may remain even after protective measures have been taken. They are called residual risks. On this machine, they may include exposure to:

- Heat, noise, exhaust, and carbon monoxide from the engine
- Burns from hot hydraulic fluid
- Fire hazards from improper refueling techniques
- Fuel and its fumes
- Personal injury from improper lifting techniques
- Crushing hazards from improper operation and for other persons in the work zone

To protect yourself and others, make sure you thoroughly read and understand the safety information presented in this manual before operating the machine.

### 1.3 Safety Guidelines for Operating the Machine

#### Operator training

Before operating the machine:

- Read and understand the operating instructions contained in all manuals delivered with the machine.
- Familiarize yourself with the location and proper use of all controls and safety devices.
- Contact Wacker Neuson for additional training if necessary.

When operating this machine:

- Do not allow improperly trained people to operate the machine. People operating the machine must be familiar with the potential risks and hazards associated with it.

---

#### Operator qualifications

Only trained personnel are permitted to start, operate, and shut down the machine. They also must meet the following qualifications:

- have received instruction on how to properly use the machine
- are familiar with required safety devices

The machine must not be accessed or operated by:

- children
- people impaired by alcohol or drugs

---

#### Application area

Be aware of the application area.

- Keep unauthorized personnel, children, and pets away from the machine.
- Remain aware of changing positions and the movement of other equipment and personnel in the application area/job site.

Be aware of the application area.

- Do not operate the machine in areas that contain flammable objects, fuels, or products that produce flammable vapors.
- Always use the SmartControl™ transmitter neck strap provided by Wacker Neuson while operating with the control cable connected. This neck strap is designed to break away so that the operator will not be dragged by the machine should the machine slide, tip, or fall.
- Always remain in visual contact with the machine at all times while operating the controls.
- Never operate multiple rollers within 20 meters (65 feet) of one another, unless you are certain that each roller and its accompanying transmitter have been set to a different control channel than the other rollers/transmitters being used within the area. Refer to section *Setting Control Channels* for additional information.

## Safety devices, controls, and attachments

Only operate the machine when:

- All safety devices and guards are in place and in working order.
- All controls operate correctly.
- The machine is set up correctly according to the instructions in the Operator's Manual.
- The machine is clean.
- The machine's labels are legible.

To ensure safe operation of the machine:

- Do not operate the machine if any safety devices or guards are missing or inoperative.
  - Do not modify or defeat the safety devices.
  - Only use accessories or attachments that are approved by Wacker Neuson.
- 

## Safe operating practices

When operating this machine:

- Remain aware of the machine's moving parts. Keep hands, feet, and loose clothing away from the machine's moving parts.

When operating this machine:

- Do not operate a machine in need of repair.
  - Do not consume the operating fluids used in this machine. Depending on your machine model, these operating fluids may include water, wetting agents, fuel (gasoline, diesel, kerosene, propane, or natural gas), oil, coolant, hydraulic fluid, heat transfer fluid (propylene glycol with additives), battery acid, or grease.
  - Use caution when operating near the edges of pits, trenches or platforms. Check to be sure that the ground surface is stable enough to support the weight of the machine with the operator and that there is no danger of the roller sliding, falling, or tipping.
  - Position yourself safely when operating machine in reverse or on hills. Leave enough space between yourself and the machine so you will not be placed in a hazardous position should the machine slide or tip.
  - Do not use a cellphone or send text messages while operating this machine.
  - Stay clear of the articulated steering joint and the area between the front and rear frames.
- 

## Personal Protective Equipment (PPE)

Wear the following Personal Protective Equipment (PPE) while operating this machine:

- Close-fitting work clothes that do not hinder movement
  - Safety glasses with side shields
  - Hearing protection
  - Safety-toed footwear
- 

## After Use

- Stop the engine when the machine is not being operated.
  - Close the fuel valve, if equipped, when machine is not being operated.
  - Ensure that the machine will not tip over, roll, slide, or fall when not being operated.
  - Store the machine in a clean, dry location out of the reach of children.
-



## 1.4 Service Safety

### Service training

Before servicing or maintaining the machine:

- Read and understand the instructions contained in all manuals delivered with the machine.
- Familiarize yourself with the location and proper use of all controls and safety devices.
- Only trained personnel shall troubleshoot or repair problems occurring with the machine.
- Contact Wacker Neuson for additional training if necessary.

When servicing or maintaining this machine:

- Do not allow improperly trained people to service or maintain the machine. Personnel servicing or maintaining the machine must be familiar with the associated potential risks and hazards.

---

### Precautions

Follow the precautions below when servicing or maintaining the machine.

- Read and understand the service procedures before performing any service to the machine.
- All adjustments and repairs must be completed before operating the machine. Do not operate the machine with a known problem or deficiency.
- All repairs and adjustments shall be completed by a qualified technician.
- Turn off the machine before performing maintenance or making repairs.
- Remain aware of the machine's moving parts. Keep hands, feet, and loose clothing away from the machine's moving parts.
- Reinstall the safety devices and guards after repair and maintenance procedures are complete.
- Always secure the articulated steering joint using the locking bar before lifting, jacking, and servicing the machine. The machine halves could swing together unexpectedly and cause a serious injury.
- Do not remove the radiator cap when the engine is running or hot. The radiator fluid is hot and under pressure and may cause severe burns!
- Do not remove air cleaner cover, paper element, or precleaner while engine is running.
- Do not leave SmartControl™ transmitter unattended while servicing machine.

---

### Machine modifications

When servicing or maintaining the machine:

- Use only accessories/attachments that are approved by Wacker Neuson.

When servicing or maintaining the machine:

- Do not defeat safety devices.
- Do not modify the machine without the express written approval of Wacker Neuson.

**Replacing parts and labels**

- Replace worn or damaged components.
  - Replace all missing and hard-to-read labels.
  - When replacing electrical components, use components that are identical in rating and performance to the original components.
  - When replacement parts are required for this machine, use only Wacker Neuson replacement parts or those parts equivalent to the original in all types of specifications, such as physical dimensions, type, strength, and material.
- 

**Cleaning**

When cleaning and servicing the machine:

- Keep the machine clean and free of debris such as leaves, paper, cartons, etc.
- Keep the labels legible.

When cleaning the machine:

- Do not clean the machine while it is running.
  - Never use gasoline or other types of fuels or flammable solvents to clean the machine. Fumes from fuels and solvents can become explosive.
- 

**Personal Protective Equipment (PPE)**

Wear the following Personal Protective Equipment (PPE) while servicing or maintaining this machine:

- Close-fitting work clothes that do not hinder movement
- Safety glasses with side shields
- Hearing protection
- Safety-toed footwear

In addition, before servicing or maintaining the machine:

- Tie back long hair.
- Remove all jewelry (including rings).

## 1.5 Safety Guidelines for Lifting the Machine

When lifting the machine:

- Make sure slings, chains, hooks, ramps, jacks, forklifts, cranes, hoists, and any other type of lifting device used is attached securely and has enough weight-bearing capacity to lift or hold the machine safely. See section *Technical Data* for machine weight.
- Remain aware of the location of other people when lifting the machine.
- Only use the lifting points and tie-downs described in the Operator's Manual.
- Make sure the transporting vehicle has sufficient load capacity and platform size to safely transport the machine.

To reduce the possibility of injury:

- Do not stand under the machine while it is being lifted or moved.
- Do not get onto the machine while it is being lifted or moved.

## 1.6 Hydraulic Fluid Safety

**WARNING**

Possibility of severe injury. Hydraulic fluid is under high pressure and becomes very hot during operation.

- ▶ To avoid injury, obey the safety instructions listed below.

**Safety instructions**

- Inspect the hydraulic system thoroughly before operating the machine.
- Do not touch hydraulic fluid or hydraulic components while the machine is operating. Wait until the machine is cool.
- Before disconnecting hydraulic fittings or hoses, ensure that all pressure has been bled from the circuit. Set all controls in neutral, turn engine off, and allow the fluids to cool before loosening hydraulic fittings or attaching test gauges.
- Hydraulic fluid escaping under high pressure may penetrate the skin, cause burns, blind, or cause other serious injuries or infections. Contact a physician immediately for treatment if your skin has been penetrated by hydraulic fluid, even if the wound seems minor.
- Fluid leaks from small holes are often practically invisible. Do not use your bare hands to check for leaks. Check for leaks using a piece of cardboard or wood.
- Hydraulic fluid is extremely flammable. Stop the engine immediately if a hydraulic leak is detected.
- After servicing the hydraulics, make sure all components are reconnected to the proper fittings. Failure to do so may result in damage to the machine and/or injury to a person on or near the machine.

## 1.7 Operator Safety while Using Internal Combustion Engines

**WARNING**

Internal combustion engines present special hazards during operation and fueling. Failure to follow the warnings and safety standards could result in severe injury or death.

- ▶ Read and follow the warning instructions in the engine owner's manual and the safety guidelines below.

**DANGER**

Exhaust gas from the engine contains carbon monoxide, a deadly poison. Exposure to carbon monoxide can kill you in minutes.

- ▶ NEVER operate the machine inside an enclosed area, such as a tunnel, unless adequate ventilation is provided through such items as exhaust fans or hoses.

**Operating safety**

When running the engine:

- Keep the area around exhaust pipe free of flammable materials.
- Check the fuel lines and the fuel tank for leaks and cracks before starting the engine. Do not run the machine if fuel leaks are present or the fuel lines are loose.

When running the engine:

- Do not smoke while operating the machine.
- Do not run the engine near sparks or open flames.
- Do not touch the engine or muffler while the engine is running or immediately after it has been turned off.
- Do not operate a machine when its fuel cap is loose or missing.
- Do not start the engine if fuel has spilled or a fuel odor is present. Move the machine away from the spill and wipe the machine dry before starting.

**Refueling safety**

When refueling the engine:

- Clean up any spilled fuel immediately.
- Refill the fuel tank in a well-ventilated area.
- Replace the fuel tank cap after refueling.
- Use suitable tools for refueling (for example, a fuel hose or funnel).

When refueling the engine:

- Do not smoke.
- Do not refuel a hot or running engine.
- Do not refuel the engine near sparks or open flames.



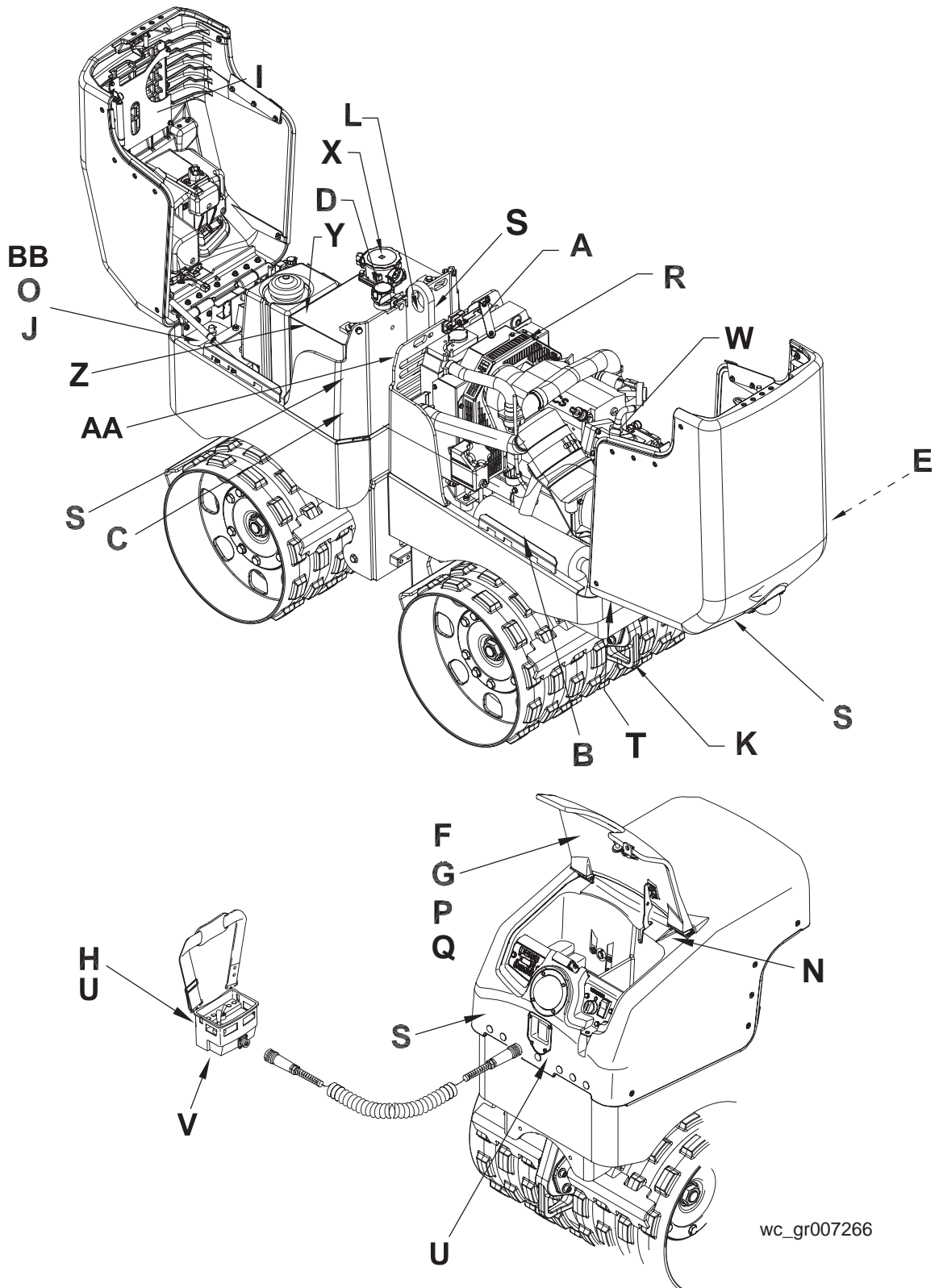

2 Labels

2.1 Label Locations







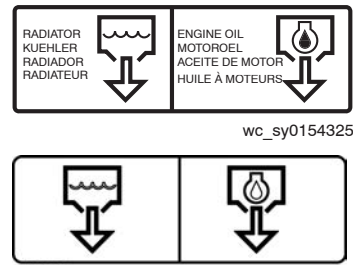

wc\_gr007266

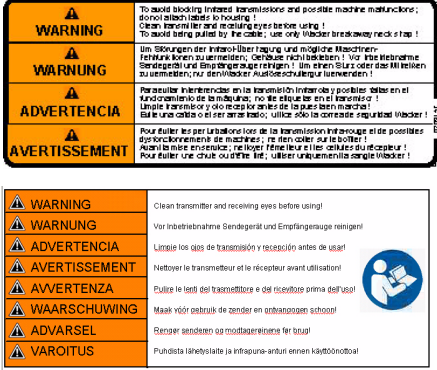

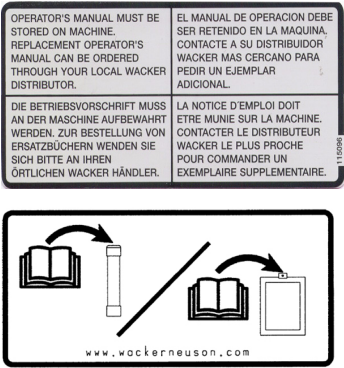
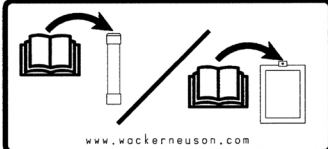
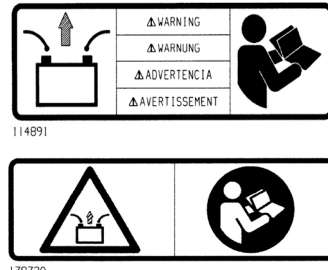
2.2 Label Meanings

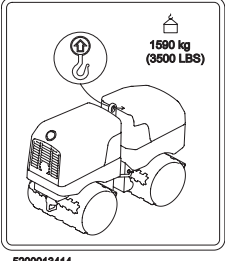

<p><b>A</b></p>	 <p>178711</p>	<p>WARNING Pressurized contents. Do not open when hot!</p>
<p><b>B</b></p>	 <p>115415 178729</p>	<p>WARNING Hot surface</p>
<p><b>C</b></p>	 <p>17873</p>	<p>WARNING! Pinch point.</p>
<p><b>D</b></p>	 <p>111760</p>	<p>Hydraulic oil reservoir fill</p>
<p><b>E</b></p>	 <p>wc_sy0154325 0178727</p>	<p>Radiator/Engine Oil</p>

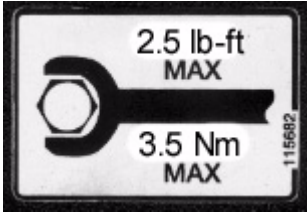
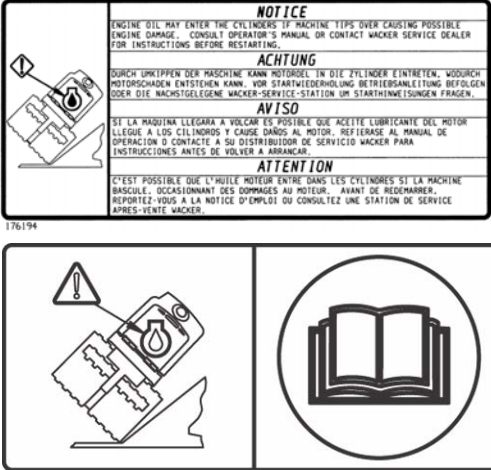

<p><b>F</b></p>	<p>0159430</p> <p>0178826</p>	<p><b>DANGER!</b></p> <p>Asphyxiation hazard.</p> <ul style="list-style-type: none"> <li>Engines emit carbon monoxide.</li> <li>Do not run the machine indoors or in an enclosed area unless adequate ventilation, through such items as exhaust fans or hoses, is provided.</li> <li>Read and understand the supplied Operator's Manual before operating the machine. Failure to do so increases the risk of injury to yourself or others.</li> <li>To reduce the risk of hearing loss, always wear hearing protection when operating this machine.</li> </ul>
<p><b>G</b></p>	<p>159431</p> <p>0178823</p>	<p><b>WARNING!</b></p> <p>Infrared signal: Always aim transmitter directly at receiving eye on machine.</p> <ol style="list-style-type: none"> <li>No travel when operator is within 2 meter (6.6 ft.) of front or rear of machine. Machine will operate when operator is within 2 meter (6.6 ft.) of either side of machine.</li> <li>Machine may receive and react to signals reflected off objects.</li> </ol> <p>Read the Operator's Manual.</p>

<p><b>H</b></p>	 <p><b>WARNING</b> To avoid blocking infrared transmissions and possible machine malfunctions, do not attach labels to housing! Clean transmitter and receiving eyes before using! To avoid being pulled by the cable, use only Wacker Neuson breakaway neck strap!</p> <p><b>WARNUNG</b> Um Sicherungen der Infrarot-Strahlung und mögliche Maschinen-Fehlfunktionen zu vermeiden, dürfen keine Aufkleber an der Maschine angebracht werden! Vor der Inbetriebnahme des Sendegeräts und des Empfängers muss das Gehäuse gereinigt werden! Um einen Sturz oder das Mitnehmen zu vermeiden, nur den Wacker Neuson Ausfallschlingel verwenden!</p> <p><b>ADVERTENCIA</b> Para evitar interferencias en la transmisión, evitar los y posibles fallos en el funcionamiento de la máquina, no se debe colocar en el transmisor o el receptor etiquetas ni adhesivos. Limpiar la lente del transmisor y del receptor antes de utilizarlos. Evitar la caída o el ser arrastrado, utilice sólo la correa de seguridad Wacker.</p> <p><b>AVERTISSEMENT</b> Pour éviter les pertes de transmission infrarouge et de possibles dysfonctionnements de machine, ne rien coller sur le boîtier. Avant la mise en service, nettoyer l'émission et les cellules du récepteur. Pour éviter une chute ou d'être tiré, utiliser uniquement la ceinture Wacker.</p> <p><b>WARNING</b> Clean transmitter and receiving eyes before using!</p> <p><b>WARNUNG</b> Vor Inbetriebnahme Sendegerät und Empfängerauge reinigen!</p> <p><b>ADVERTENCIA</b> Limpiar los ojos de transmisión y recepción antes de usar!</p> <p><b>AVERTISSEMENT</b> Nettoyer le transmetteur et le récepteur avant utilisation!</p> <p><b>AVERTENZA</b> Pulire le lenti del trasmettitore e del ricevitore prima dell'uso!</p> <p><b>WAARSCHUWING</b> Maak vóór gebruik de zender en ontvanger schoon!</p> <p><b>ADVASEL</b> Rens de zender en ontvanger voor gebruik!</p> <p><b>VAROITUS</b> Puhdista lähdeosia ja infrapuna-anturi ennen käyttöönottoa!</p> 	<p>To avoid blocking infrared transmissions and possible machine malfunctions, do not attach labels to housing! Clean transmitter and receiving eyes before using! To avoid being pulled by the cable, use only Wacker Neuson breakaway neck strap!</p> <p>Clean transmitter and receiving eyes before using! Read the Operator's Manual.</p>
<p><b>I</b></p>	 <p>OPERATOR'S MANUAL MUST BE STORED ON MACHINE. REPLACEMENT OPERATOR'S MANUAL CAN BE ORDERED THROUGH YOUR LOCAL WACKER DISTRIBUTOR.</p> <p>EL MANUAL DE OPERACION DEBE SER RETENIDO EN LA MAQUINA. CONTACTE A SU DISTRIBUIDOR WACKER MAS CERCA PARA PEDIR UN EJEMPLAR ADICIONAL.</p> <p>DIE BETRIEBSVORSCHRIFT MUSS AN DER MASCHINE AUFBEWAHRT WERDEN. ZUR BESTELLUNG VON ERSATZBÜCHERN WENDEN SIE SICH BITTE AN IHREN ÖRTLICHEN WACKER HÄNDLER.</p> <p>LA NOTICE D'EMPLOI DOIT ETRE MUNIE SUR LA MACHINE. CONTACTER LE DISTRIBUTEUR WACKER LE PLUS PROCHE POUR COMMANDER UN EXEMPLAIRE SUPPLEMENTAIRE.</p>  <p>www.wackerneuson.com</p> <p>180562</p>	<p>Operator's Manual must be stored on machine. Replacement Operator's Manual can be ordered through your local Wacker Neuson distributor.</p>
<p><b>J</b></p>	 <p><b>WARNING</b> Disconnect battery before servicing. Read the Operator's Manual.</p> <p><b>WARNUNG</b></p> <p><b>ADVERTENCIA</b></p> <p><b>AVERTISSEMENT</b></p>    <p>114891</p> <p>176730</p>	<p><b>WARNING</b> Disconnect battery before servicing. Read the Operator's Manual.</p>
<p><b>K</b></p>		<p>Tie-down point</p>
<p><b>L</b></p>	 <p>1690 kg (3500 LBS)</p> <p>5200013414</p>	<p><b>NOTICE</b> Lifting point</p>

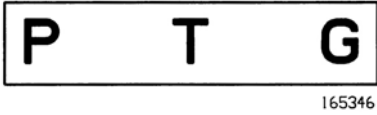

<p><b>N</b></p>		<p>This machine may be covered by one or more patents.</p>
<p><b>O</b></p>		<p>Torque battery hold-down nuts to 3.5 Nm (2.5 ft.lbs.) max.</p>
<p><b>P</b></p>		<p><b>NOTICE</b>          Engine oil may enter the cylinders if machine tips over, causing possible engine damage. Consult Operator's Manual or contact your Wacker Neuson Service Dealer for instructions before restarting.</p>
<p><b>Q</b></p>		<p>Guaranteed sound power level in dB(A).</p>

<p>R</p>	 <p>178717</p>	<p>WARNING</p> <p>Entanglement hazard. Rotating machinery. Do not reach inside machine when engine is running.</p>
<p>S</p>	 <p>110892</p>	<p>CAUTION!</p> <p>Do not stand within 2m (6.6 ft.) of the machine when the amber control lights are flashing. The roller will respond to remote signals when the light is flashing.</p>
<p>T</p>	 <p>112216 DRAIN</p>	<p>Hydraulic oil drain</p>

<p><b>U</b></p>	<p>CHANNEL LABELS: MARK THE OPERATING CHANNEL ON BOTH TRANSMITTER AND ROLLER. REPLACE ORIGINAL LABEL WITH NEW WHEN CHANNELS ARE CHANGED.</p> <p>KABALAUFLEBER: BEDENUNGSKANAL SOWOHL AUF SEBBER ALS AUCH WALZE MARKIEREN, URSPRUENGLICHEN AUFLEBER MIT EINEM NEUEN ERSETZEN, WENN DIE KANALES GEANDERT SIND.</p> <p>CALCOMANIA PARA CANAL: MARQUE EL CANAL DE CONTROL TANTO EN EL TRANSMISOR COMO EN EL RODILLO. REEMPLACE CALCOMANIA ORIGINAL CON UNA CALCOMANIA NUEVA CUANDO CANALES SON CAMBIADOS.</p> <p>AUTOCOLLANT POUR CANAL: MARQUER L'AUTOCOLLANT DE COMMANDE SUR L'EMETTEUR ET LE ROULEAU. REMPLACER L'AUTOCOLLANT ORIGINAL PAR UN AUTOCOLLANT NOUVEAU QUAND LES CANAUX SONT CHANGEES.</p> 	<p>Channel labels: Mark the operating channel on both the transmitter and roller. Replace original label with new when channels are changed.</p>								
<p><b>V</b></p>	<table border="1"> <tr> <td style="text-align: center;">▲ <b>CAUTION</b></td> <td>To avoid unintended operation when using multiple machines, select different channel settings for each machine! To avoid transmitter damage and possible malfunction, do not open housing! See Operator's Manual.</td> </tr> <tr> <td style="text-align: center;">▲ <b>VORSICHT</b></td> <td>Um unkontrolliertes Fahren bei Benutzung mehrerer Maschinen zu vermeiden; unterschiedliche Kanaladressen wählen! Um Beschädigungen und mögliche Fehlfunktionen des Senders zu vermeiden; Gehäuse nicht öffnen! Siehe Betriebsanleitung!</td> </tr> <tr> <td style="text-align: center;">▲ <b>ATENCIÓN</b></td> <td>Para evitar una operación descontrolada durante uso de varias máquinas; seleccione un canal diferente para cada máquina! Para evitar daños y posibles fallas del transmisor; no abra la caja del transmisor! Vea el manual de operación!</td> </tr> <tr> <td style="text-align: center;">▲ <b>ATTENTION</b></td> <td>Pour éviter la conduite incontrôlée lors de l'utilisation de plusieurs machines; sélectionner différents canaux! Pour éviter des détériorations et de possibles dysfonctionnements de l'émetteur; ne pas ouvrir le boîtier! Voir la notice d'utilisation!</td> </tr> </table>	▲ <b>CAUTION</b>	To avoid unintended operation when using multiple machines, select different channel settings for each machine! To avoid transmitter damage and possible malfunction, do not open housing! See Operator's Manual.	▲ <b>VORSICHT</b>	Um unkontrolliertes Fahren bei Benutzung mehrerer Maschinen zu vermeiden; unterschiedliche Kanaladressen wählen! Um Beschädigungen und mögliche Fehlfunktionen des Senders zu vermeiden; Gehäuse nicht öffnen! Siehe Betriebsanleitung!	▲ <b>ATENCIÓN</b>	Para evitar una operación descontrolada durante uso de varias máquinas; seleccione un canal diferente para cada máquina! Para evitar daños y posibles fallas del transmisor; no abra la caja del transmisor! Vea el manual de operación!	▲ <b>ATTENTION</b>	Pour éviter la conduite incontrôlée lors de l'utilisation de plusieurs machines; sélectionner différents canaux! Pour éviter des détériorations et de possibles dysfonctionnements de l'émetteur; ne pas ouvrir le boîtier! Voir la notice d'utilisation!	<p>To avoid unintended operation when using multiple machines, select different channel settings for each machine! To avoid transmitter damage and possible malfunction, do not open housing! See Operator's Manual!</p>
▲ <b>CAUTION</b>	To avoid unintended operation when using multiple machines, select different channel settings for each machine! To avoid transmitter damage and possible malfunction, do not open housing! See Operator's Manual.									
▲ <b>VORSICHT</b>	Um unkontrolliertes Fahren bei Benutzung mehrerer Maschinen zu vermeiden; unterschiedliche Kanaladressen wählen! Um Beschädigungen und mögliche Fehlfunktionen des Senders zu vermeiden; Gehäuse nicht öffnen! Siehe Betriebsanleitung!									
▲ <b>ATENCIÓN</b>	Para evitar una operación descontrolada durante uso de varias máquinas; seleccione un canal diferente para cada máquina! Para evitar daños y posibles fallas del transmisor; no abra la caja del transmisor! Vea el manual de operación!									
▲ <b>ATTENTION</b>	Pour éviter la conduite incontrôlée lors de l'utilisation de plusieurs machines; sélectionner différents canaux! Pour éviter des détériorations et de possibles dysfonctionnements de l'émetteur; ne pas ouvrir le boîtier! Voir la notice d'utilisation!									
<p><b>W</b></p>		<p>P=Power relay T= Throttle relay G= Glowplug relay</p>								
<p><b>X</b></p>		<p>Hydraulic oil reservoir fill.</p>								

<p><b>Y</b></p>	<p>173440</p> <p>0178715</p>	<p><b>DANGER!</b></p> <p>Asphyxiation hazard.</p> <ul style="list-style-type: none"> <li>Engines emit carbon monoxide.</li> <li>Do not run the machine indoors or in an enclosed area unless adequate ventilation, through such items as exhaust fans or hoses, is provided.</li> <li>Read the Operator's Manual.</li> <li>No sparks, flames, or burning objects near the machine.</li> <li>Stop the engine before refueling.</li> </ul> <p>Use only clean, filtered diesel fuel.</p>
<p><b>Z</b></p>	<p>0180563</p>	<p>Low sulfur fuel or ultra low sulfur fuel only.</p>
<p><b>AA</b></p>	<p>5200005890</p>	<p><b>WARNING</b></p> <p>Explosion hazard. Do not use evaporative starting fluids such as ether on this engine. The engine is equipped with a cold starting aid. Using evaporative starting fluids can cause an explosion which can cause engine damage, personal injury, or death. Read and follow the engine starting instructions in this Operator's Manual.</p>
<p><b>BB</b></p>	<p>0183199</p> <p>Hg Cd Pb</p>	<p><b>WARNING</b></p> <ul style="list-style-type: none"> <li>Keep all sparks and open flames away from the battery.</li> <li>Wear eye protection.</li> <li>Keep away from children.</li> <li>Battery acid is poisonous and corrosive.</li> <li>Read the Operator's Manual.</li> <li>Explosion hazard.</li> </ul> <p>Dispose of waste batteries in accordance with local environmental regulations. Battery contains mercury (Hg), cadmium (Cd), or lead (Pb).</p>

### 3 Lifting and Transporting

#### 3.1 Lifting the Machine

Lock front and rear machine halves together using the joint locking bar **(b)** at the articulated steering joint on the machine. Use a lifting device with sufficient weight-bearing capacity. Lift machine from lifting eye **(c)**.

ALWAYS lock the articulated steering joint before lifting the machine.

#### 3.2 Transporting the Machine

When transporting the machine, place blocks in front of and behind each drum and use the tie down lugs **(a)** provided to securely fasten the machine to the trailer.

Make sure that the joint locking bar **(b)** is engaged.

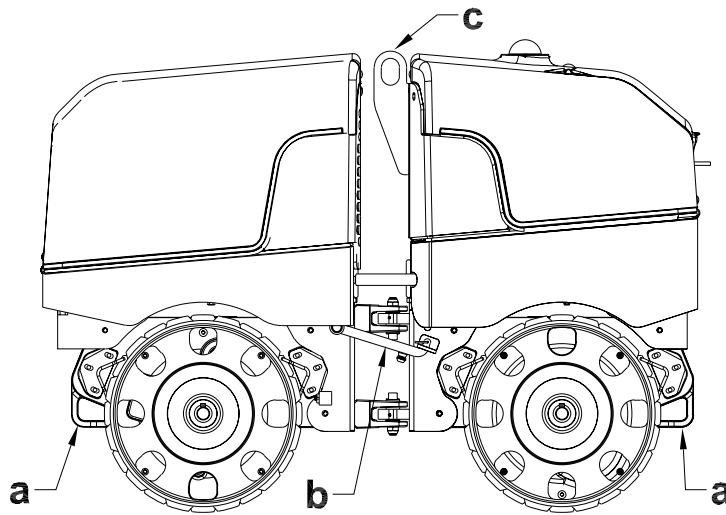

wc gr000980

Notes



## 4 Operation

### 4.1 Preparing the Machine for First Use

1. Make sure all loose packaging materials have been removed from the machine.
2. Check the machine and its components for damage. If there is visible damage, do not operate the machine! Contact your Wacker Neuson dealer immediately for assistance.
3. Take inventory of all items included with the machine and verify that all loose components and fasteners are accounted for.
4. Attach component parts not already attached.
5. Add fluids as needed and applicable, including fuel, engine oil, and battery acid.
6. Move the machine to its operating location.

4.2 Control / Component Locations

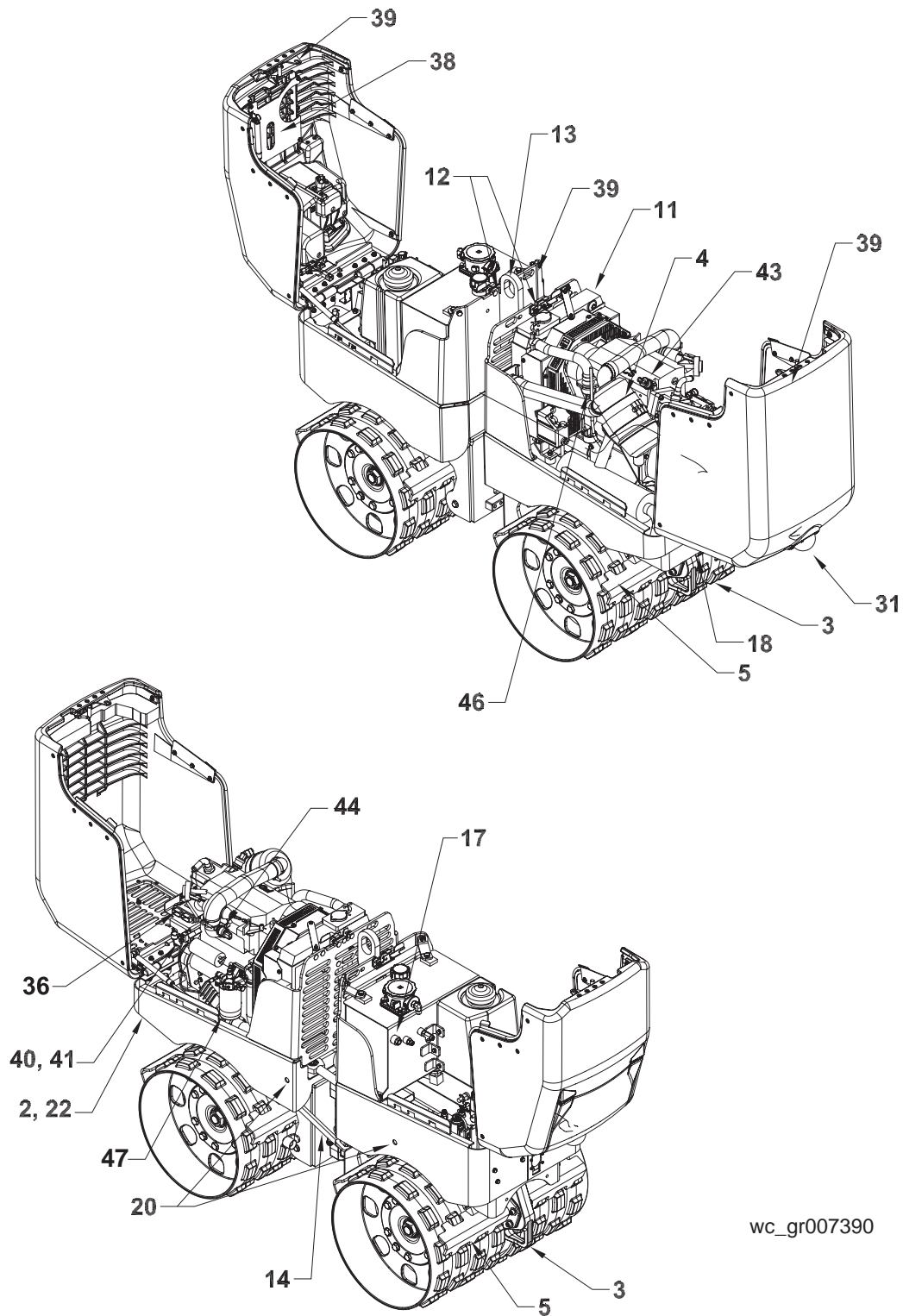

wc\_gr007390



## 4.3 Control / Component Descriptions

Ref.	Description	Ref.	Description
1	Oil dipstick	28	Display panel
2	Engine oil drain plug	29	SmartControl™ transmitter
3	Tie-down lugs	30	Charge cable
4	Air cleaner	31	Receiving eye/light ring
5	Scraper bar	32	Oil cooler
9	Exciter pump	33	Docking port
10	Drive pump	34	Steering cylinder
11	Radiator	35	Decoder module
12	Hood latch	36	Engine Control Module (ECM)
13	Lifting eye	37	Latch
14	Articulated joint locking bar	38	Manual holder
15	Hydraulic tank	39	Hood locking tab
16	Hydraulic tank return line filter	40	System fuse - 20A
17	Hydraulic oil level sight gauge	41	Self-resetting circuit breaker - 50A
18	Hydraulic tank drain plug	42	Charge cord / Service box receptacle
19	Articulated joint grease fitting	43	Oil PSI switch
20	Steering cylinder grease fittings	44	Air filter restriction switch
21	Fuel tank	46	High water temperature switch / Glow plug timer
22	Radiator drain plug	47	Fuel filter
23	Hydraulic manifold	—	—
24	Battery	—	—

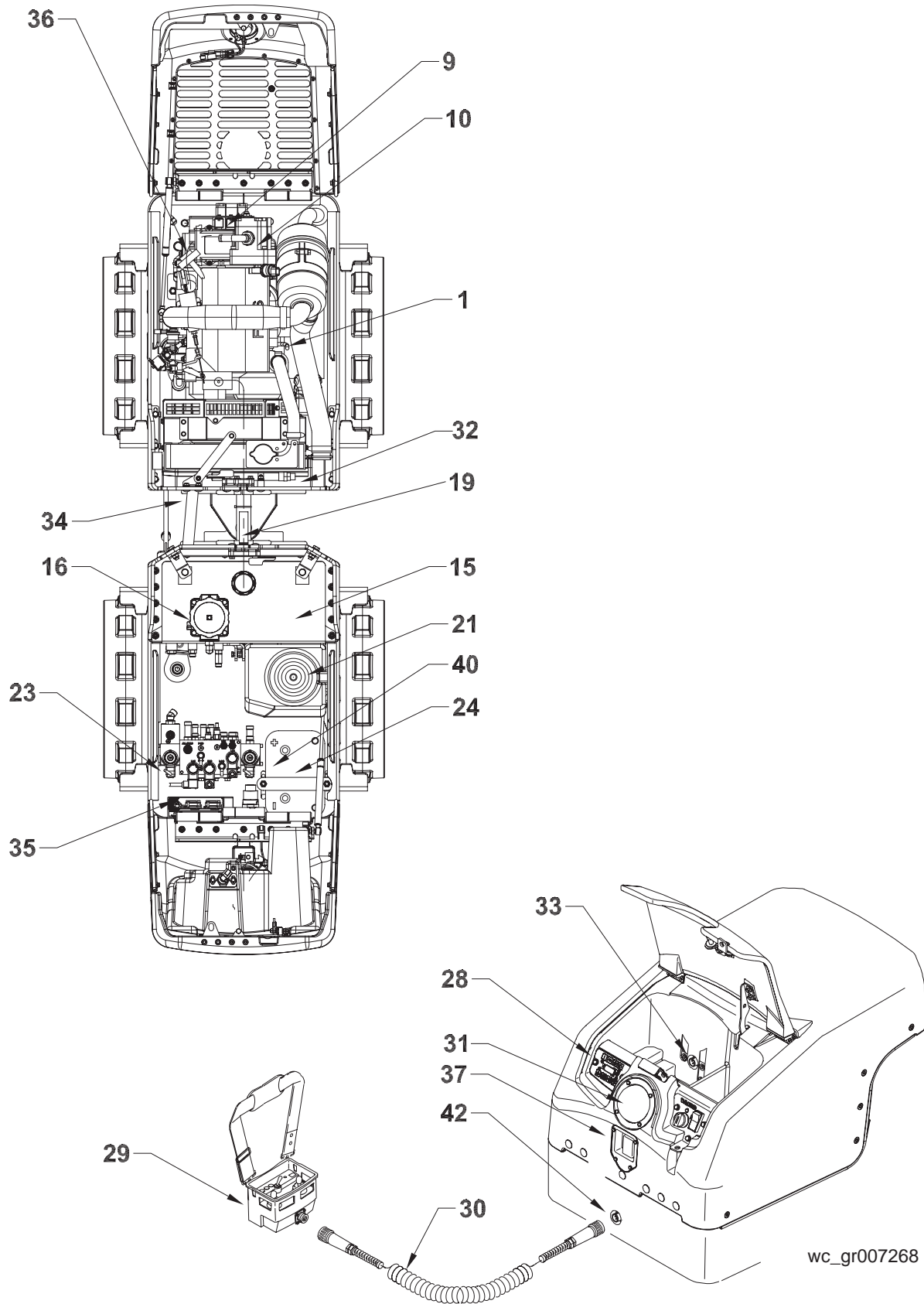

wc\_gr007268

Ref.	Description	Ref.	Description
1	Oil dipstick	28	Display panel
2	Engine oil drain plug	29	SmartControl™ transmitter
3	Tie-down lugs	30	Charge cable
4	Air cleaner	31	Receiving eye/light ring
5	Scraper bar	32	Oil cooler
9	Exciter pump	33	Docking port
10	Drive pump	34	Steering cylinder
11	Radiator	35	Decoder module
12	Hood latch	36	Engine Control Module (ECM)
13	Lifting eye	37	Latch
14	Articulated joint locking bar	38	Manual holder
15	Hydraulic tank	39	Hood locking tab
16	Hydraulic tank return line filter	40	System fuse - 20A
17	Hydraulic oil level sight gauge	41	Self-resetting circuit breaker - 50A
18	Hydraulic tank drain plug	42	Charge cord / Service box receptacle
19	Articulated joint grease fitting	43	Oil PSI switch
20	Steering cylinder grease fittings	44	Air filter restriction switch
21	Fuel tank	46	High water temperature switch / Glow plug timer
22	Radiator drain plug	47	Fuel filter
23	Hydraulic manifold	—	—
24	Battery	—	—

4.4 Features and Controls

This machine is designed specifically for remote control operation. This feature protects the operator by allowing him or her to stand at a distance from the machine, and the work area, during operation. When used in excavations, it allows the operator to stand safely above the trench, rather than in it.

The SC-2 transmitter (a) is designed for infra-red (IR) remote-controlled operations only. The coil cord (b) is only used for charging the transmitter battery or supplying power to the transmitter when there is no battery. No control signals are sent through the cord.

The infra-red system includes the transmitter and two receiving eyes. This system provides wireless line-of-sight operation up to 20 meters (65 feet). It uses a hand-held transmitter to transmit signals to the receiving eyes on the machine to control machine operation. Only one eye needs to receive a signal for proper operation.

When operating multiple rollers within 20 meters (65 feet) of one another, it is possible that the transmitter from one roller can inadvertently take control of another roller. This can occur when multiple rollers are set to the same control channel as that of one transmitter. To prevent the transmitter from one roller inadvertently taking control of another roller, be certain that each roller and its accompanying transmitter are set to a different control channel than the other rollers/transmitters being used within the area. Refer to section *Infra-red System and Control Channels* for additional information.

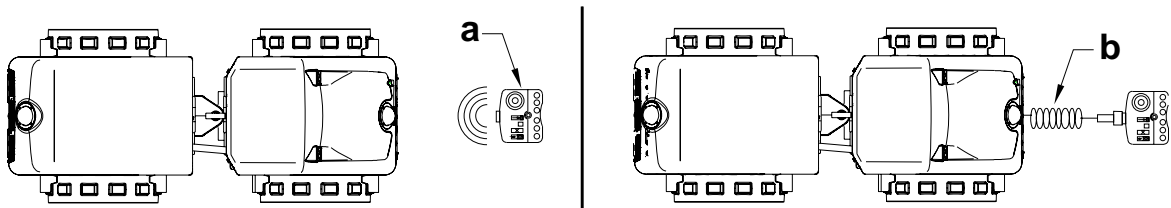

wc\_gr000957

## 4.5 Accessing the Engine or Hydraulic Component Compartments

**To access the engine or hydraulic component compartments:**

1. Reach into slot in cover and press latch release **(a)** until latch opens.
2. Raise hinged cover and place in the open position.

**To close:**

3. Position cover over the compartment, near the closed position.
4. Being careful not to pinch fingers or hands, release cover and allow weight of cover to engage latch.

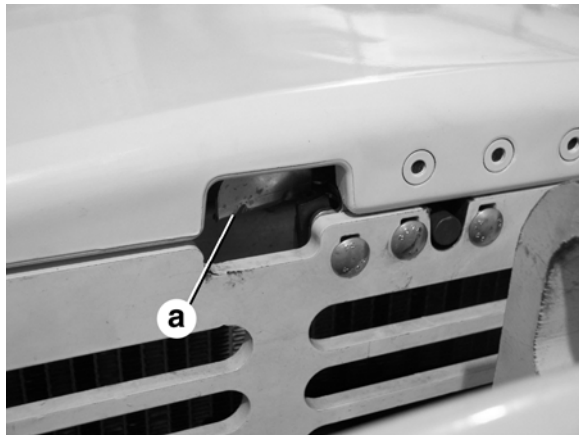

wc\_gr001725

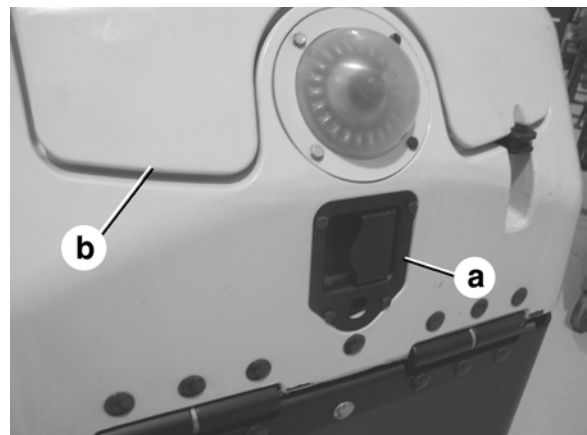

wc\_gr001726

## 4.6 Accessing the Control Compartment

**Requirement** Engine stopped

---

**Procedure** Follow the procedure below to access the control compartment.

---



**CAUTION**

The control compartment lid is spring-loaded.

- ▶ Stay clear when opening the lid, and do not place any objects on the lid when opening.
- 

1. To open, pull latch **(a)** handle to release the latch.
2. To close, position the cover over the compartment, near the closed position.

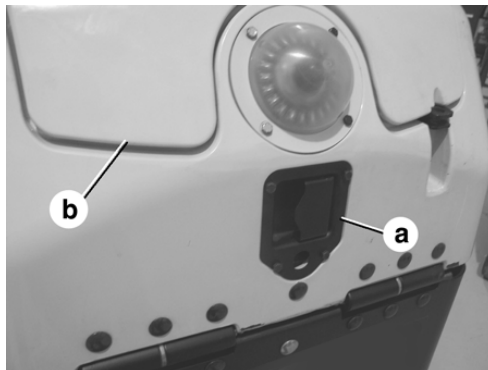

wc\_gr001726

3. Being careful not to pinch fingers or hands, with hand on top side of lid **(b)**, force the lid into the closed position until the latch secures the lid.

### 4.7 Control Panel

The control panel is mounted to the dash under the back hood access cover of the machine. It contains the following features:

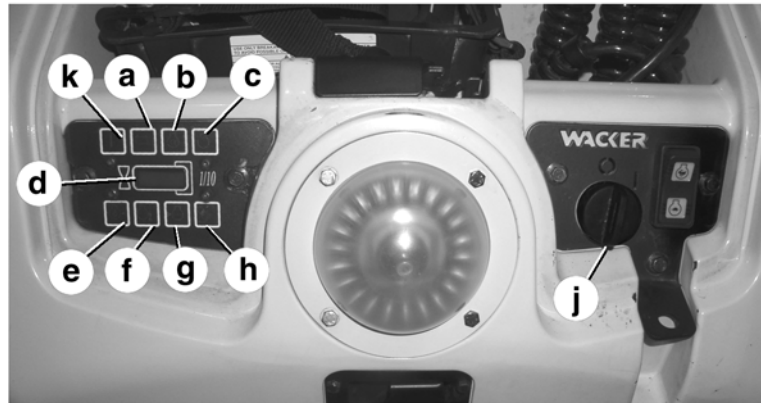

wc\_gr001728

	Component	Description
a	Charging system light	The engine is equipped with an alternator and voltage regulator to maintain the battery charge. The charging system warning light illuminates when there is a malfunction of the system. Although the machine will run with the light on for a short period of time, continued operation will drain the battery and eventually cause the machine to lose all operating functions. If the system warning light illuminates while operating the machine in a narrow trench or other confined area, drive machine into a safer area as soon as possible to avoid stranding it in a hazardous or inaccessible location.
b	Glow plug light	The engine is equipped with an automatic glow plug system that pre-heats the combustion chambers to improve normal and cold weather starts. The glow plug light illuminates when the keyswitch and the transmitter ON/OFF switch are placed in the I (ON) positions. It will go off when the combustion chambers are pre-heated. Note: Allow 5 minutes for the engine to warm up before operating the roller.
c	Air cleaner light	The air cleaner warning light illuminates when the air filter cartridge needs to be replaced.

	Component	Description
d	Hour meter	The hour meter records the actual running time of the engine. Use the hour meter when planning scheduled maintenance.
e	Engine oil pressure light	The oil pressure warning light illuminates when oil pressure falls below the engine manufacturer's recommended value. During such a condition, the engine will automatically shut down.
f	Coolant temperature light	The cooling temperature warning light illuminates when engine coolant temperature exceeds 230°F (110°C). During such a condition, the engine will automatically shut down. Note: Allow temperature to drop below 212°F/100°C before attempting to restart.
g	Coolant level light	The cooling level warning light illuminates when coolant level is too low. During such a condition, the engine will automatically shut down.
h	Stability light	The stability warning light illuminates when the pitch of the roller exceeds 45°. The machine is equipped with safety switches that shut down the engine during such a condition.
j	Keyswitch	Turning the keyswitch to the I (ON) position supplies power to the machine. The green power-on indicator (k) illuminates indicating power is on. The keyswitch has an automatic shutoff feature that powers off the electronics after 1 hour of non-engine run time. To reset the machine, turn the keyswitch to the O (OFF) position and then back to the I (ON) position. Note: The machine can be restarted within this 1-hour period if the transmitter is turned off and then on. The glow plugs will be activated if needed. All shutdown functions have a fault detection feature where the warning light and red LED light rings remain on after the machine shuts down, until the fault is corrected, and the keyswitch is turned to the O (OFF) position. All shutdown functions and the air filter restriction circuit have built-in circuitry to detect a possible bad sensor, unplugged sensor, or a cut or damaged wire to the sensor. Whenever any of these sensor faults occur, the corresponding control panel light will flash on and off.



### 4.8 SmartControl™ SC-2 Transmitter

- Wireless control
- Line of sight operation
- 16 control channels
- Clear transmissions into direct sunlight, up to 130,000 LUX
- Maximum range: 20m (65 ft.)
- Transmitting time (full charge): 12 hours
- Recharge time (full charge): 2-1/2 hours
- Battery: Ni-MH (nickel metal hydride) battery pack

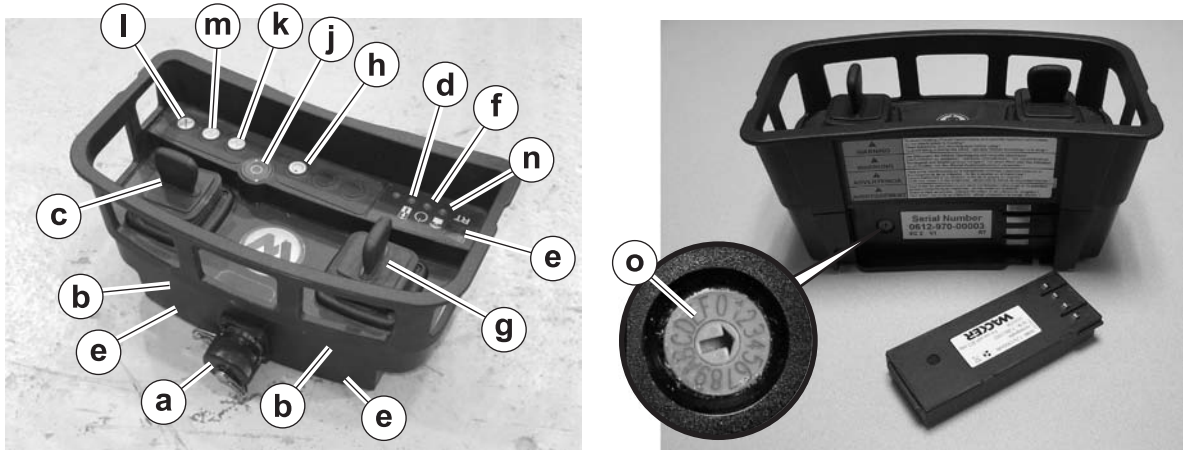

wc\_gr006335

Ref	Component	Description
a	Cable connector	The cable connector provides a connection point for the transmitter cord. When the transmitter cord is connected, the transmitter battery recharges while the engine is running.
b	Infra-red emitting diodes	The diodes—located on all sides of the transmitter—are used to transmit the coded infra-red signal to the receiving eyes on the machine.  Keep the transmitter clean to ensure maximum signal strength.
c	Forward/reverse (travel) joystick	The right joystick (c) controls forward/reverse motion.
g	Left/right (steering) joystick	The left joystick (g) controls left/right motion.  Move the joysticks in the direction desired. The roller will change to high speed whenever the travel joystick is placed fully in the forward or fully in the reverse position.
d	Battery charge indicator	This LED illuminates green while the battery is charging.

Ref	Component	Description
e	Near field transmitting diodes (LEDs)	These LEDs—located on all sides of the transmitter—are part of the machine's sensing system which stops the machine when the operator and transmitter are located too close to the machine.
f	Operating status indicator	This LED indicates the operating status of the transmitter.  See <i>Operating Status Indicator Codes</i> .
h	Engine START pushbutton	Pressing this button causes the engine to crank. An override prevents the engine from cranking if it is already running.
j	ON/OFF pushbutton	Pressing this button turns on and off the SmartControl™ transmitter. The operating status indicator (f) illuminates green (flashing) when the transmitter is on.  Turning the transmitter off stops the engine and the machine.
k	LOW vibration pushbutton	Pressing this button causes the vibration to come on in the LOW vibration mode.
l	Vibration OFF pushbutton	Pressing this button causes all vibration to stop.
m	HIGH vibration pushbutton	Pressing this button causes the vibration to come on in the HIGH vibration mode.
—	Vibration pushbuttons	When the machine is moving in the high speed travel mode, pressing either vibration pushbutton (k or m) causes the roller to drop out of the high speed travel mode and into the low speed travel mode. Conversely, when the vibration is on, the machine cannot go into the high speed travel mode.
n	Signal transmission indicator	To aid in diagnostics, this green LED flashes any time a signal is sent to the roller.
o	Control channel selector switch	This selector switch, when set to match that of the machine's decoder module, allows the SmartControl to control the roller.

## 4.9 Operating Status Indicator Codes

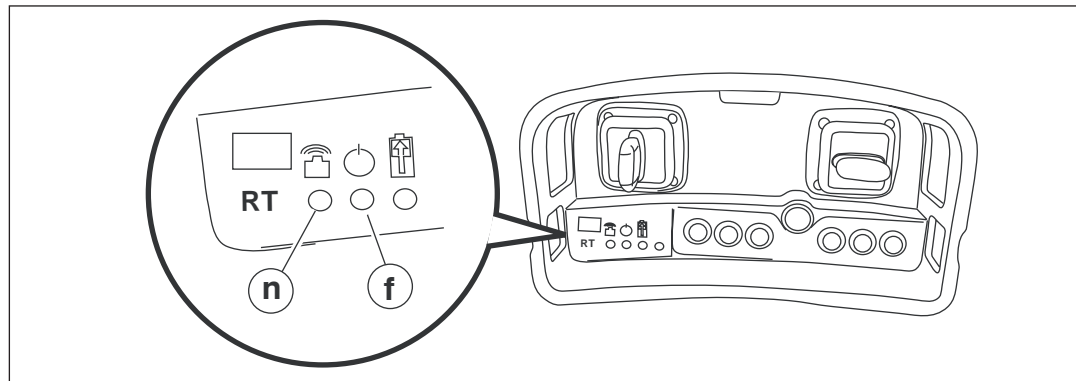

wc\_gr010837

Ref.	Color and appearance	Status	Transmitter function	Cause / Remedy
f	None	Off	Off	No power: transmitter is OFF. No power: battery is discharged.
	Green (blinking slowly)	On (normal)	Normal operation	Transmitter is operating normally.
	Green (steady)	Setup mode	Awaiting joystick calibration.	See <i>Calibrating the Joysticks</i> .
	Green (blinking fast)	Calibration mode	Transmitter is in calibration mode, and the calibration procedure can be performed.	See <i>Calibrating the Joysticks</i> .
	Red to green to yellow (cycling)	Most recent joystick calibration had an error.	Machine operation may still be possible depending on amount of usable data available.	Joystick(s) incorrectly calibrated. Middle position of joystick(s) is not being detected. ▶ Recalibrate joysticks.
	Red and green (alternating)	Under-voltage fault	Weak signal communication.	Battery charge is low. ▶ Recharge or replace battery.
	Red (flashing every second)	Under-voltage fault	Transmission has stopped. Transmitter unable to control the machine.	Discharged battery. ▶ Recharge or replace battery.
	Red (blinking rapidly)	Joystick calibration is required	Transmitter unable to control the machine.	▶ Calibrate joysticks ▶ If calibration does not solve the problem, contact Wacker Neuson Product Support.
	Red (steady)	Near-field or circuit board error	No transmission: transmitter unable to control the machine.	Hardware fault. Contact Wacker Neuson Product Support.
f	Green (blinking fast)	Joystick or function key error	Transmitter unable to control the machine.	Operating error within a function key, or one or both joysticks. ▶ Contact Wacker Neuson Product Support.
n	Red (steady)			

## 4.10 Infra-red System and Control Channels

The infrared (IR) system consists of three main components: the SmartControl™ SC-2 transmitter (**a**), the receiving eyes (**b**), and the decoder module (**c**).

The receiving eyes are positioned on the top of the machine enclosed within protective lenses. They receive, filter and amplify the infrared transmission. They include:

- An integrated pre-amp to strengthen signal input
- IR correction, to filter outside light interference
- A frequency range of 500 kHz

There is an amber LED (**d**) on the base (bottom) of each eye. When illuminated, the amber LED indicates:

- Electric power is being supplied to the eye. The LED illuminates for the first 1–2 seconds after power has been applied (key switch is turned on).
- The eye is receiving a signal from the SmartControl™ SC-2 transmitter module. The LED will remain on during operation.

The decoder module is positioned behind the hydraulic manifold at the back of the machine. It receives, decodes, and outputs the signal from the transmitter module. It is also the electric power supply for all hydraulic solenoids.

The IR system can be set to one of sixteen different control channels. Using different channels allows multiple rollers to operate in the same area without interference. Whenever multiple rollers are operated within 20 meters (65 feet) of one another, make certain each roller and its accompanying transmitter is set to a different control channel than the other rollers/transmitters being used within the area.

Channel selection rotary switches (**e** and **f**) are included on both the transmitter module and on the decoder module. The switches come from the factory set to the last digit of the machine's serial number. For proper operation, BOTH switches must be set to the SAME channel. The channel of each transmitter/machine pair is identified by a label on both on the transmitter and the machine.

To change the control channel:

1. Remove the transmitter module battery and rotate the selector switch to the desired position. Re-install the transmitter module battery.
2. Set the rotary switch on the decoder module to the same position as that of the rotary switch on the transmitter module.
3. To determine if the decoder module and the transmitter module are set to the same channel, turn the key switch to the ON position and set the transmitter module's ON/OFF switch to the ON position. The amber lights on the machine's light ring should blink at a slow rate indicating that the machine is receiving signals from the transmitter module. If the amber lights illuminate but do not blink, the transmitter module and the decoder module are not set to the same channel.
4. Change the channel identification label to match the selected channel each time the channel is changed. Channel identification labels are supplied with the Operator's Manual.

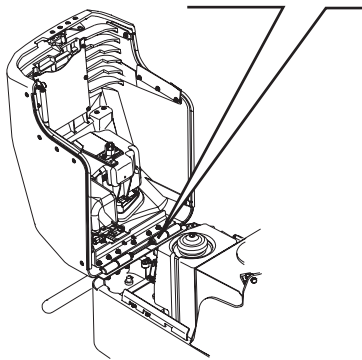
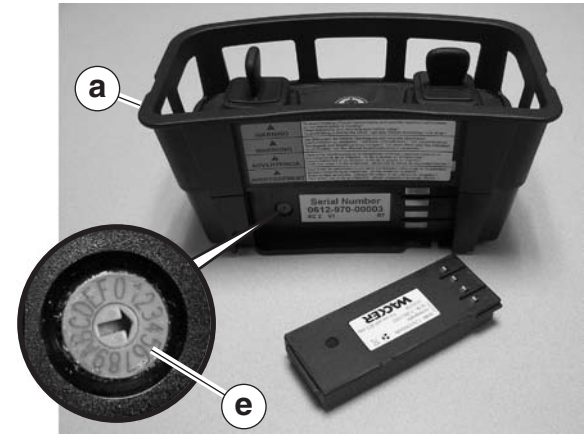
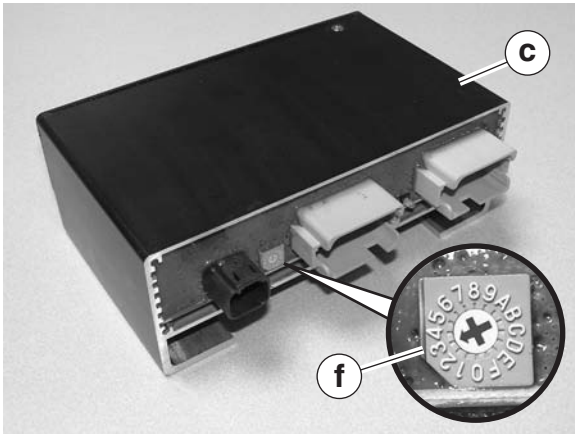
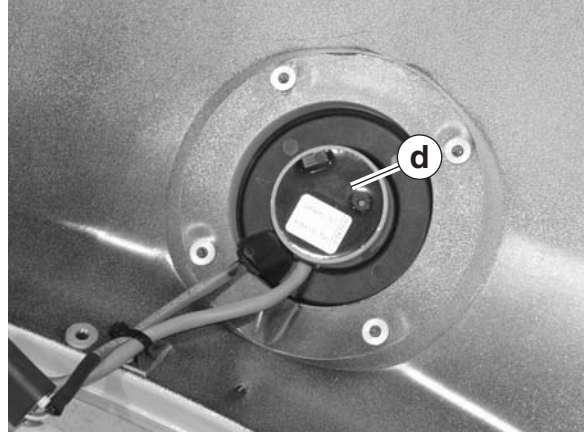
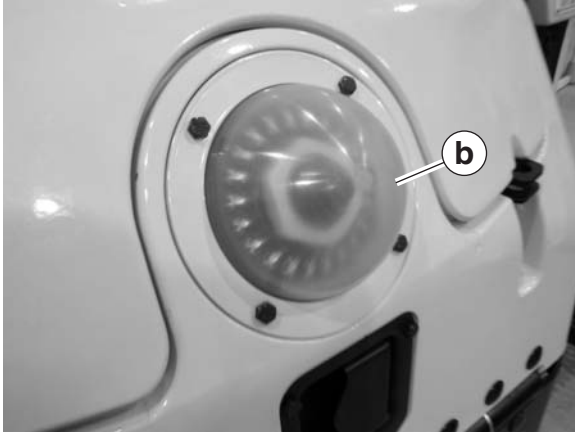

wc\_gr003923

4.11 Before Starting

Before starting the machine check the following:

- Engine oil level
- Hydraulic fluid level
- Condition of fuel lines
- Condition of air cleaner
- Fuel level
- Water level
- Scraper bars are clean and properly adjusted
- Check that the SmartControl™ transmitter module and the machine's decoder module are set to the same control channel.

**Note:** All fluid levels should be checked with the machine on a level surface.

Ensure that regular maintenance has been carried out.

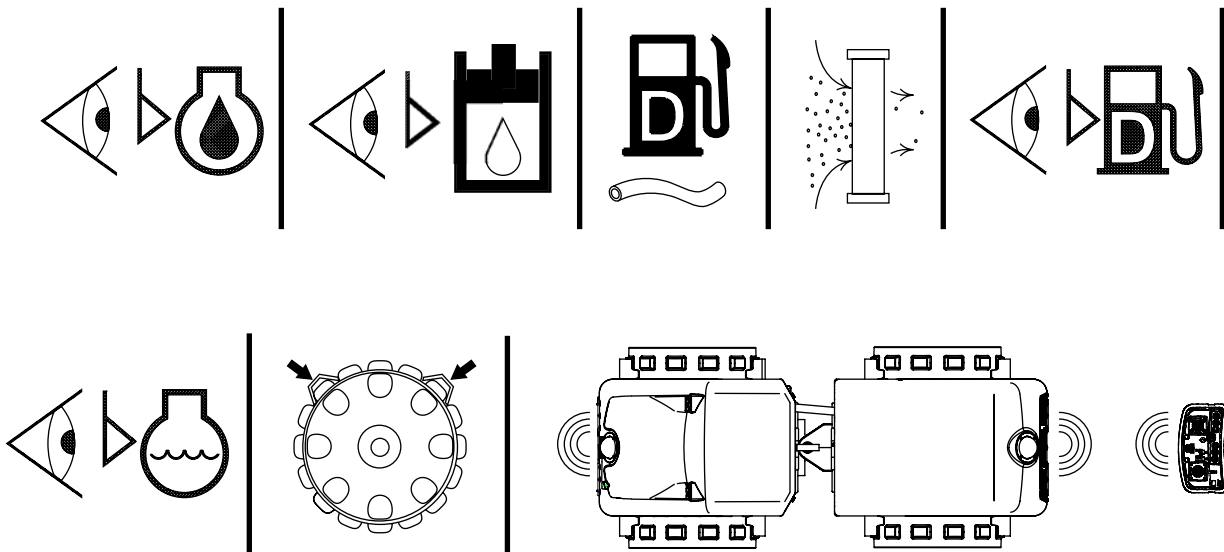

wc\_gr003062

## 4.12 Starting

1. Place the throttle switch **(b)** in the idle (slow) position.
2. Turn the key switch **(a)** to the **I** (ON) position. All lights on the display/control panel and the light ring **(q)** (both red and amber) will illuminate for a 5-second LED test. After 5 seconds, all lights go off except the power ON indicator **(h)**, charge indicator **(i)**, engine oil pressure indicator **(l)**, and the amber LEDs of the light ring which remain illuminated.
3. Turn on the SmartControl™ SC-2 transmitter by pressing the red ON/OFF pushbutton **(d)**. Make sure the amber indicator lights in the light rings **(q)** are flashing at a slow rate. This indicates infrared reception and that the transmitter is at the correct distance from the machine. If they are not flashing, it indicates that either the transmitter is not on or that the control channel of the transmitter does not match the control channel of the machine. If they are flashing at a fast rate (three times per second), it indicates that the transmitter (and operator) are too close to the machine. Reposition the SmartControl™ SC-2 transmitter so that the indicator lights flash at a slow and steady rate. If you are operating multiple rollers, check to make certain each roller and its accompanying transmitter are set to a different control channel.
4. After approximately 2 seconds, if engine conditions dictate (coolant temperature too cool), the glow plug indicator **(j)** will illuminate and the light ring will flash red, signifying that the glow plugs are on. The colder the engine coolant temperature, the longer the glow plugs will stay on; approximately 30 seconds at 0°C (32°F).

**Note:** *The starter will not crank when the glow plugs are on.*

5. Immediately after the glow plug light **(j)** and red light ring **(q)** go out, press the engine start pushbutton **(g)** and hold it down until the engine starts. If the machine fails to start within 20 seconds of cranking, release the engine start pushbutton. Press the red ON/OFF pushbutton to turn the transmitter off. Wait 30 seconds, then turn the transmitter back on and repeat the starting procedure.
6. Once started and sufficient oil pressure is sensed, the oil pressure indicator will go out.
7. Allow the unit to warm up a minimum of 5 minutes before engaging the throttle switch **(b)** to the *high* (fast) position.

### 4.13 Stopping

1. Turn the vibration off by pressing vibration off pushbutton **(f)**.
2. Place the throttle switch **(b)** in the idle (slow) position.

**Note:** *The engine cannot be shut down using the throttle control alone. The throttle switch only changes the engine speed from high (fast) to idle (slow).*

3. Turn off the SmartControl™ SC-2 transmitter by pressing the red ON/OFF pushbutton **(d)**. The machine's engine will shut down.
4. Turn the key switch **(a)** to the **O** (OFF) position.

**Note:** *The machine has a built-in shutoff timer. If the key is left in the ON position when the engine is not running, the timer will shut off the power to the control panel after one hour.*

A parking brake is located in the rear drum. The brake is connected to the hydraulic system through the brake valve of the control manifold. The brake is spring activated and hydraulically disengaged. Hydraulic oil flow to the brake is enabled as soon as the engine starts. Thus, when the engine is running, the brake is disengaged; when the engine is not running, the brake is engaged.

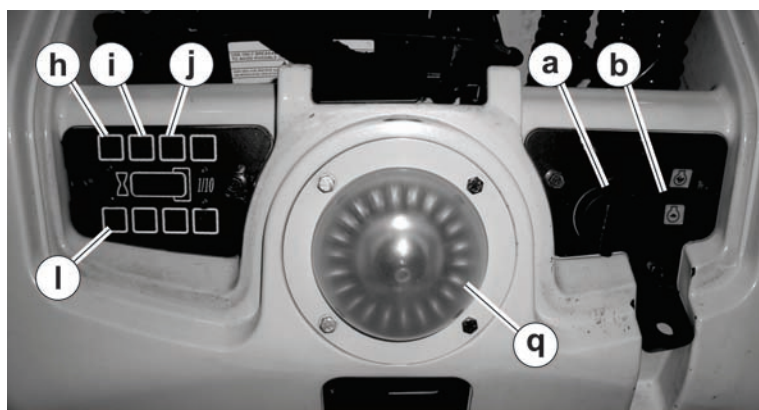

wc\_gr006336



## 4.14 Light Ring Color Codes

Color—Code	Mode	Reason / Remedy
Amber—solid	Non communication	Machine's key in ON position, but: <ul style="list-style-type: none"> <li>• Transmitter is not turned on.</li> <li>• Transmitter battery is dead.</li> <li>• Transmitter not pointed at machine.</li> <li>• Transmitter too far from machine.</li> <li>• Transmitter and decoder are on different channels.</li> <li>• Communication fault (see topic <i>Communication Faults</i>)</li> </ul>
Amber—slow flash	Normal operation	Machine is receiving proper signal from transmitter and is operational.
Amber—fast flash	Operator safety	Machine is receiving signal but operator is too close to machine. <ul style="list-style-type: none"> <li>• Move farther than two meters (6 feet) from machine until amber lights flash slowly.</li> </ul>
Red—solid	Machine shut down	Critical error has occurred such as: tip over, low oil pressure, or high coolant temperature. <ul style="list-style-type: none"> <li>• For tip over: Turn key OFF, upright machine. See topic <i>Resetting the ECM Diagnostic Data and the Tip-Over Light</i>.</li> <li>• For low oil pressure: Turn key OFF. Check oil. Restart as normal.</li> <li>• For high coolant temperature: Turn key OFF. Allow machine to cool. Add coolant.</li> </ul>
Red—slow flash	Automatic glow plug	Glow plugs are preheating engine. No functions allowed until preheat cycle is complete.
Red—fast flash	Over voltage	Machine is receiving more than 18 Volts due to non-12V system used for jump starting. <ul style="list-style-type: none"> <li>• Replace machine's 12V battery.</li> <li>• Do not jump-start the machine.</li> </ul>

## 4.15 Operation

Clean the transmitter and receiver eyes prior to operation.

Keep the transmitter pointed at either of the receiving eyes on the machine for continued operation. The light ring amber LEDs will blink to show that the machine is receiving signals from the transmitter.

The infrared system is equipped with an operator distance sensing system. If the operator is standing within 1–2 m (3–6 ft.) of the front or rear of the machine, the amber light ring will flash rapidly, and the machine will not travel forward/reverse or vibrate until the operator moves outside the 1–2 m (3–6 ft.) distance. Once the operator is at the correct distance, the amber lights will flash slowly to indicate the machine can be operated.

**Note:** *The control cable is not needed for using the infrared system.*

The SmartControl™ SC-2 transmitter battery can be recharged at the end of operation by connecting the transmitter receptacle **(b)** to the battery docking port **(c)**. See *Charging Transmitter Batteries*.

The Cable Control System will only charge the transmitter battery if the control cable is connected to the transmitter receptacle **(b)** and plugged into the port **(a)** in the back of the roller.



**CAUTION**

Multiple rollers are not to be operated within 20 meters (65 feet) of one another, unless you are certain you have each roller and its accompanying transmitter set to a different control channel than the other rollers/transmitters being used within the area. Refer to section *Infra-red System and Control Channels* for additional information. Failure to assign different control channels can, in certain circumstances, cause one transmitter to inadvertently take control of more than one machine.



**WARNING**

Always use the SmartControl™ SC-2 transmitter neck strap provided by Wacker Neuson while operating with the control cable connected. This neck strap is designed to break away so that the operator will not be dragged by the machine should the machine slide, tip, or fall.

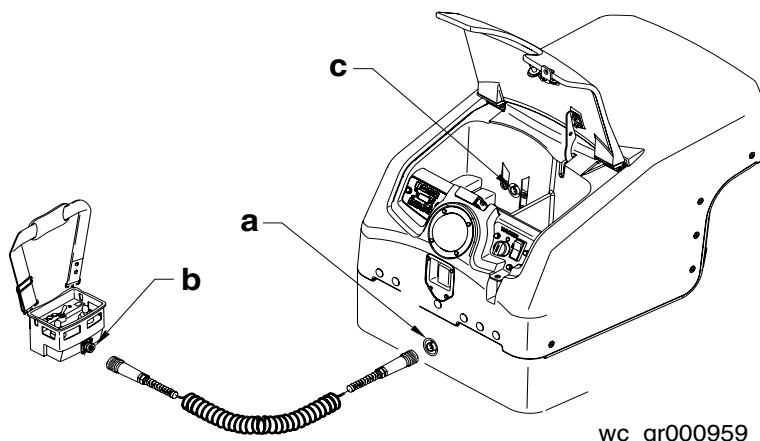

## 4.16 Position of the Operator

Although either receiving eye on the machine can receive signals from any direction, the switches on the transmitter are positioned so that they correspond to the movements of the machine with the operator standing **BEHIND** it.

For example, when standing behind the machine (**a**), pushing forward on the forward/reverse joystick causes the machine to move away from the operator, pushing left on the steering joystick results in the machine turning left, etc.

As the operator changes positions in the work area, it is important that he or she understands the changes that will occur in the control of the machine.

If the operator stands in front of the machine (**b**), it will respond in a direction opposite in relation to the operator. That is, pushing forward causes the machine to move toward the operator; pushing left results in the machine turning to the operator's right. Operating the machine while standing in front of it is not recommended.



**WARNING**

Do not stand closer than 2m (6.6 ft.) to the roller when operating the roller from either side. The roller's sensing system will not stop the roller from moving when the transmitter is in the storage compartment or on the side of the roller. The machine senses its distance from the transmitter only to the front and rear of the machine when the receiving eyes have a clear view of the transmitter. When operating from the side of the machine, always maintain a distance of at least 2m (6.6 ft.) from the machine. Never operate the machine with the transmitter in the storage compartment.



**WARNING**

The roller will stop if it approaches the operator but will not stop if it approaches other personnel. **ALWAYS** be sure that all other persons are at a safe distance from the machine. Stop the machine if people step into the work area of the machine.

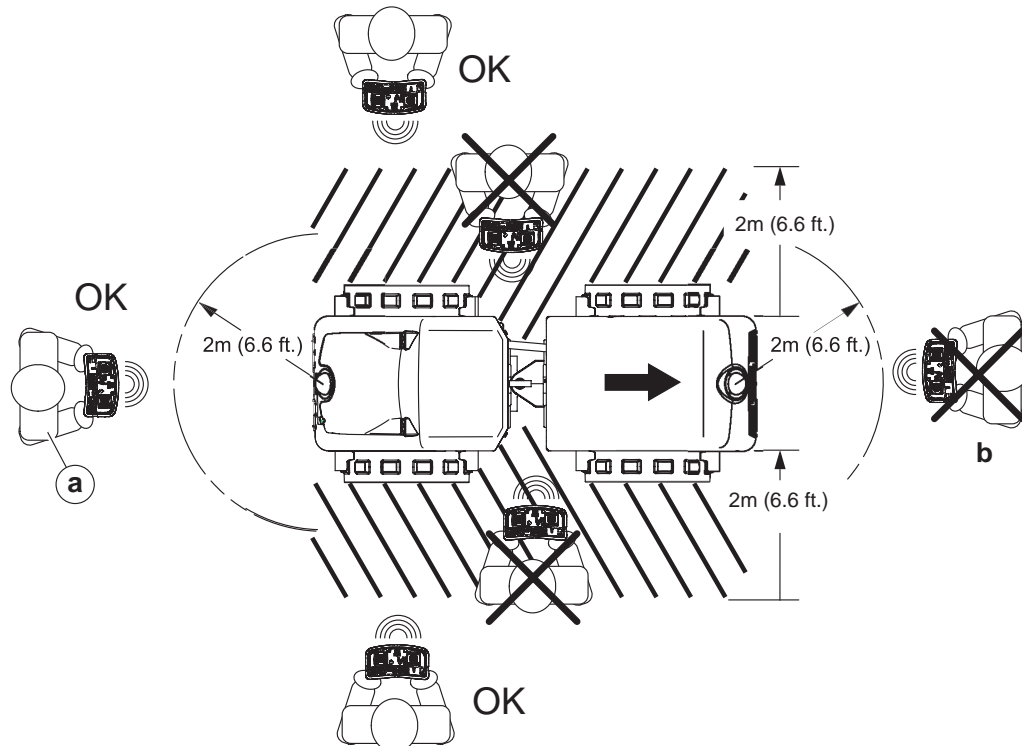

wc\_gr003925

### 4.17 Range Limits

The transmitter signal will remain in contact with the machine at distances up to 20 m (65 ft). If operating into direct sunlight or with a low battery charge, the operating range may decrease.

If the machine moves out of range, the amber lights on the machine will stop blinking and come on continuously. The machine will immediately stop moving, and vibration will stop. The operator must then move closer to the machine to re-establish contact. If contact is not made within 30 seconds, the engine will shut off.

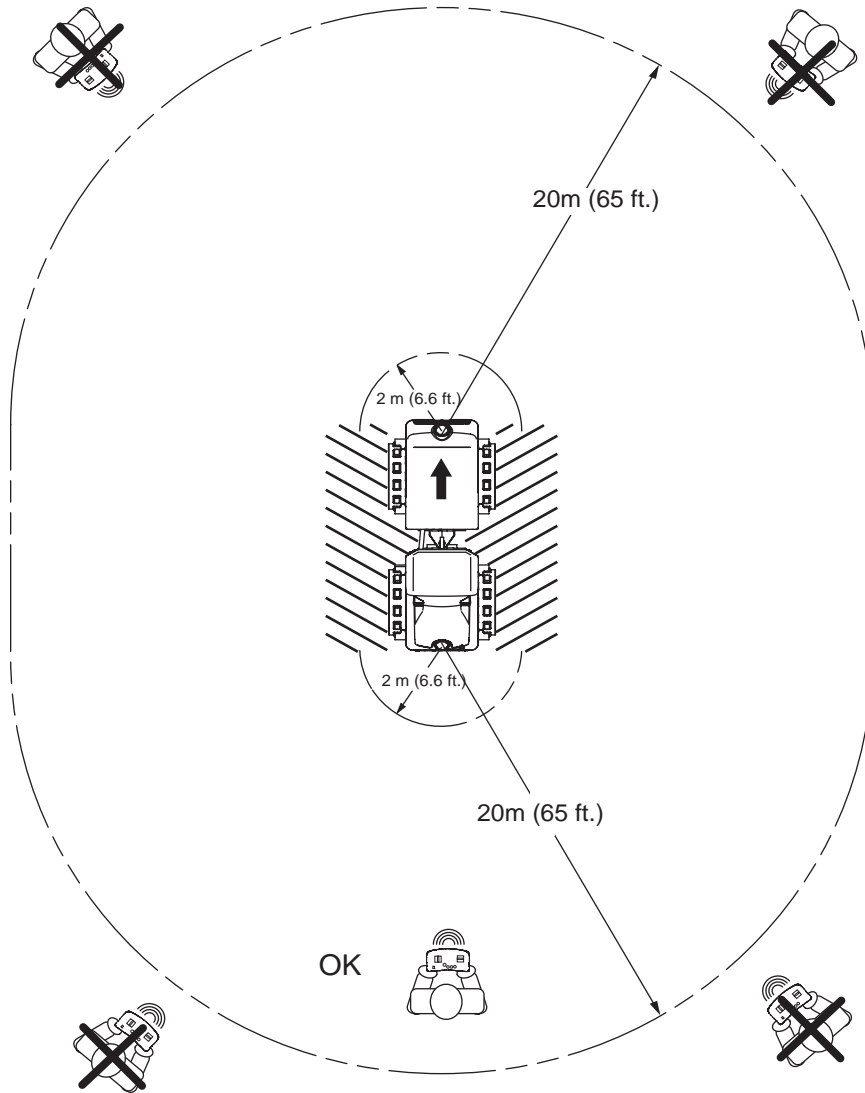

wc\_gr003926

## 4.18 Operating Characteristics



### WARNING

Personal injury or equipment damage hazards. The roller's sensing system will not stop the roller from moving when the transmitter is in the storage compartment or on the side of the roller.

- ▶ When operating from the side of the machine, always maintain a distance of at least 2m (6.6 ft.) from the machine.
- ▶ Never operate the machine with the transmitter in the storage compartment.

- In some instances, objects passing between the machine and transmitter (such as support beams) will block the signal. When this occurs, the machine will stop moving. If the signal is not re-established within 30 seconds, the engine will shut down.
- In an enclosed area (such as a shop floor or warehouse) or an area surrounded by large structures, the infra-red signal may reflect off surrounding surfaces, causing it to be picked up by the machine even when the transmitter is pointed away from the machine. This condition is more pronounced at shorter distances when the signal strength is strong.
- As the distance between the transmitter and machine increases, the intensity of the signal diminishes.

## 4.19 Communication Faults

**Description** The decoder has built-in diagnostics that continuously check for a faulty signal transmitted from the receiving eyes to the decoder. If a faulty signal is detected, the decoder stops machine movement and the light rings illuminate solid amber.

**Fault correction** Communication faults may occur when a receiving eye is damaged. The faults vary in frequency and duration. When a normal signal is restored, the light rings slowly flash amber and machine movement is restored.

If communication faults occur regularly, check the condition of the receiving eyes. Replace damaged components as needed.

## 4.20 NiMH Battery

The battery used to power the transmitter is a high capacity Nickel Metal Hydride (NiMH) cell rated at 2000 mAh and is capable of accepting hundreds of charging cycles. If the machine fails to operate for the full operating period, even after the battery has been fully discharged and recharged, the battery pack may need to be replaced.

Charging characteristics:

- Time to fully charge: 2 hours
- Full-charge operating time: 16 hours\*
- Operating time after 1 hour charge: 8 hours\*
- At temperatures below 0°C, charging is not possible

\* Operating time decreases at severely cold temperatures.

## 4.21 Replacing the Battery Pack

The battery pack (a) on the back of the transmitter should be replaced once a year or when it no longer holds a full charge.

To replace the battery pack press the orange tab (b) and slide the battery pack out.

**Note:** A new battery may not be fully charged. After replacing the battery, charge it for approximately one hour to ensure it is at full capacity.

**Note:** In the interests of environmental protection, dispose of used batteries properly. DO NOT dispose in trash, or incinerate.

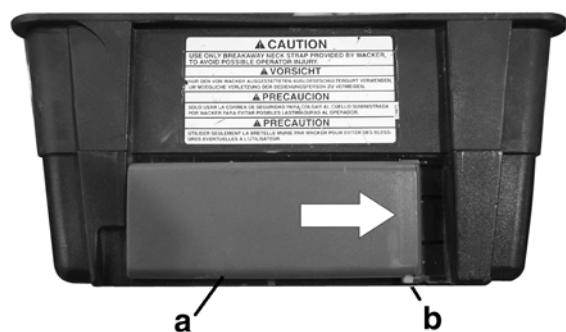

wc\_gr001666

## 4.22 Charging the Transmitter Battery

The NiMH battery pack **(b)** in the transmitter has enough capacity to provide 16 hours of continuous operation. To maintain battery capacity, recharge it during non-working hours by using the onboard docking port.

**Note:** *There is no need to run the NiMH battery completely down before recharging. The battery can be recharged from any state of discharge with no loss in performance or life.*

### Procedure

To charge the battery, perform one of the following procedures:

- Plug the transmitter receptacle **(a)** into the charging port **(b)**. Slide the transmitter forward until the battery charge light comes on.



### WARNING

Personal injury or equipment damage hazards. The roller's sensing system will not stop the roller from moving when the transmitter is in the storage compartment or on the side of the roller.

- ▶ When operating from the side of the machine, always maintain a distance of at least 2m (6.6 ft.) from the machine.
- ▶ Never operate the machine with the transmitter in the storage compartment.

- Plug one end of the control cable into the transmitter receptacle **(a)** and the other end into the port **(c)** on the back of the machine.

**Note:** *Using the second method requires the machine to be running or the keyswitch to be in the "ON" position.*

### Charging time

Approximately 2 hours is required to bring the transmitter battery up to full charge. This is the most efficient way to use the battery. The transmitter will operate with a partially charged battery; however, its operating time will be reduced accordingly.

**Note:** *The charging circuit in the transmitter is self-regulating and limits the charging current to the battery, so that the battery cannot be overcharged.*

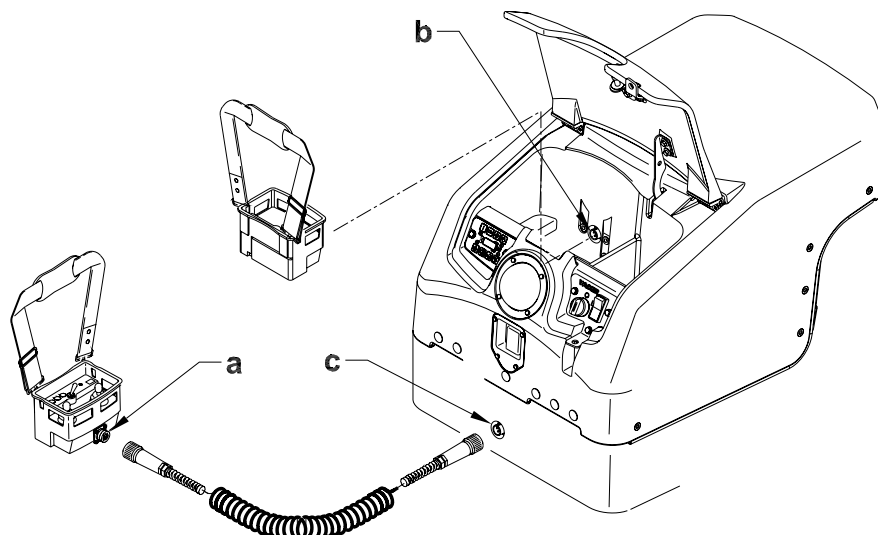

wc\_gr001031

### 4.23 Machine Stability



**WARNING**

Crushing hazards. Certain job site conditions or operating practices may adversely affect machine stability.

- ▶ Follow the instructions below to reduce the risk of tipping or falling incidents.

**Surface conditions**

Pay attention to changing surface conditions while operating the machine. Adjust speed and travel direction as necessary to maintain safe operation.

- Machine stability and traction may be severely reduced when operating on uneven or rough terrain, rocky soils, or wet or loosely packed surface material.
- The machine may suddenly tip, sink, or fall when moved onto surfaces that have been newly filled with earth.

**Steering angle**

An articulated roller is more likely to tip when moving off an elevated surface if the machine is turned away from the edge.

- As shown in the illustration on the right, always turn the machine toward the edge when moving off an elevated surface.



wc\_gr007076

**Travel speed**

A fast moving machine is more likely to tip or fall over while making turns or changing direction.

- Reduce travel speed before turning the machine.

**Drum overhang**

The machine can tip suddenly if more than half of the drum width extends beyond the edge of the elevated surface.

- Reduce travel speed and watch the drum position carefully when operating along the edge of an elevated surface.
- Keep as much of the drum on the elevated surface as possible.

**Vibrating on a compacted surface**

Activating the vibratory system on a fully compacted surface may cause the drums to rebound and momentarily lose contact with the ground. If this occurs while the machine is on an incline, the machine may slide.

- If the drums rebound on the compacted surface, reduce vibration speed or stop vibration entirely.

When operating on slopes or hills special care must be taken to reduce the risk of personal injury or damage to the equipment. Whenever possible, operate machine



up and down hills rather than from side to side to improve stability and reduce the possibility of a rollover. The machine is equipped with safety switches which will shut down the engine should the side-to-side operating angle exceed 45°. Forward/backward tilt is not limited by the safety switches. For safe operation and for protection of the engine, continuous duty use should be restricted to slopes of 14° (25% grade) or less.



NEVER operate machine on side slopes greater than 26° (50% grade). At slopes greater than this, the machine may roll over, even on stable ground.

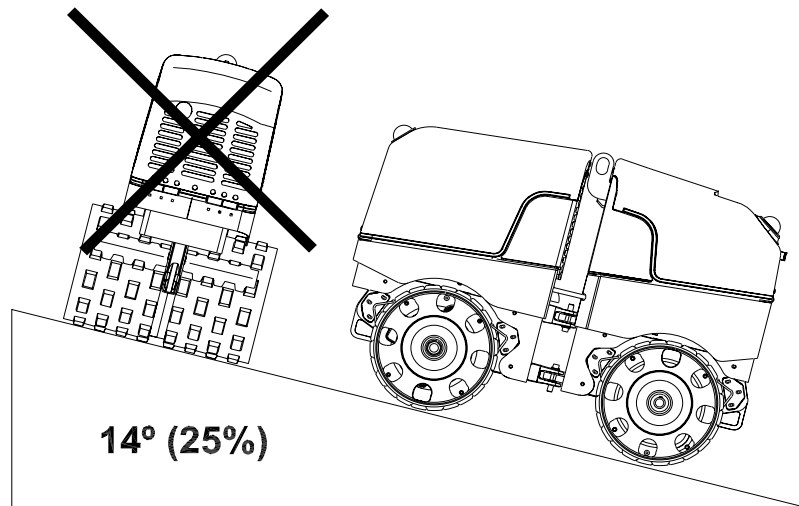

wc\_gr000238

## 4.24 Articulated Joint Locking Bar

A bar is provided to lock the articulated joint, and prevent the two machine halves from swinging together.

When lifting or jacking up the machine, secure the articulated joint with the bar as shown. Hold bar in position using the cotter pin **(a)** provided.

When operating the machine, place the bar in the storage clamp **(b)** as shown.

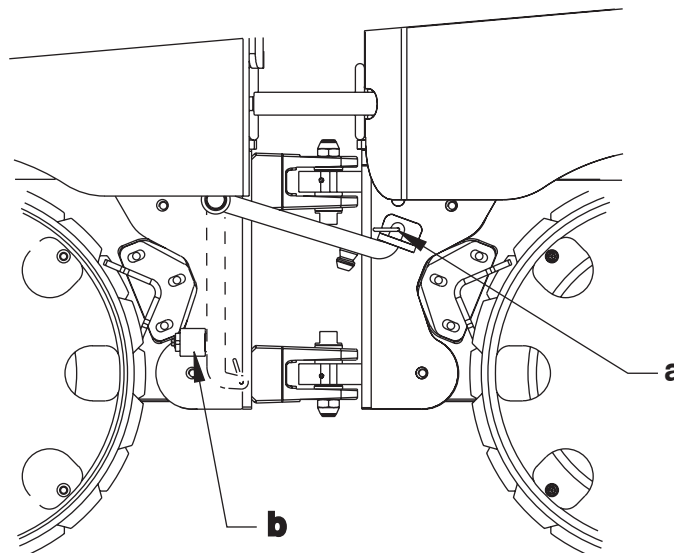

wc\_gr000239

## 4.25 Tip-Overs

Proper operation of the machine on slopes will prevent rollovers. If a machine tip-over does occur, care must be taken to prevent damage to the engine. In this position, oil from the engine crankcase can flow into the combustion chamber, which can severely damage the engine next time it is started. If the machine has rolled on its side, **immediate** steps should be taken to right the machine.

**NOTICE:** To prevent damage to the engine after a tip-over, the machine must NOT be started, AND must be serviced to remove any oil that may have been trapped in the combustion chambers. Contact your local Wacker Neuson dealer for instructions or servicing.

A tip over is indicated by the tip-over light which flashes when in the "FLASH LED" mode or stays on solid when in the "LOCK OUT START" mode. See section *Programming the ECM Tip Over Mode*.

## 4.26 Emergency Shutdown Procedure

If a breakdown/accident occurs while the machine is operating, follow the procedure below.

1. Turn off the transmitter to stop the engine and close the fuel valve.
2. Turn the roller keyswitch to the OFF position.
3. Return the machine to an upright position if tipped over.
4. Contact rental yard or machine owner.

## 4.27 Overview of the ECM and the Diagnostic Tool

The RT SC-2 Roller features an Engine Control Module (ECM) with diagnostic and programmable abilities. The diagnostics are conveyed via alpha-numeric codes displayed on three LED displays that are viewable through the plastic case of the ECM. These diagnostic/program abilities include:

- The ability to view the stages of engine start-up.
- The ability to view seven fault conditions and over 35 error codes.
- The ability to lockout or allow engine start after a machine tip-over.

A diagnostic tool, which comes standard with the machine, is used to interface with the ECM.

### 4.28 ECM Stages of Engine Start Up

The ECM displays codes as the machine goes through the start up sequence. These codes are described below.

**Note:** *It is not necessary to enter the diagnostic mode to view these codes.*

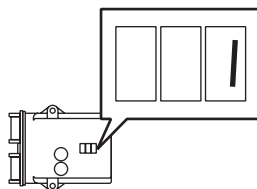

Code	State	Description
<ul style="list-style-type: none"> <li>■ 8.8.8 for 3 seconds</li> <li>■ E 1.x for 2 seconds</li> <li>■ F_L or F_O for 3 seconds</li> </ul>	Power up	Power up delay cycle. Software version. Current tip over/roll over mode.
1	Stop/Idle	During this state, power is applied to the ECM and decoder but the engine is off. The ECM is waiting for the start signal to initiate the glow plug cycle.
2	Preglow	During this state, the glow sensor determines the glow time and power is applied to the glow plugs. This cycle starts immediately after the control box power switch is placed in the ON position.
3	Prestart	Post preglow state. The ECM is waiting for the starting cycle.
4	Start	Power is being applied to starter.
5	Post glow	5 second post glow after engine start.
6	Run	Standard running mode.
7	Fault	All functions stopped. Waiting repeat of power up cycle.  Faults that produce engine shut down: <ul style="list-style-type: none"> <li>■ low oil pressure</li> <li>■ over temperature</li> <li>■ tip over</li> <li>■ over voltage</li> </ul>

## 4.29 ECM Monitoring of Solenoids

The ECM monitors the wiring to, and condition of, the fuel solenoid and the wiring to, and condition of, the starter solenoid.

If the wire **(a)** to the fuel solenoid is disconnected or the fuel solenoid is faulty, the following results occur.

- The control panel indicators **(b)** will flash immediately after the transmitter is turned on.
- The red LEDs of the light ring will illuminate solid red.
- The engine will not crank.

Reconnect the wire or replace the fuel solenoid to enable the machine to start.

If the wire **(c)** to the starter solenoid is disconnected or the starter solenoid is faulty, the following results occur.

- The control panel indicators **(b)** will flash immediately after the starter pushbutton is pressed.
- The red LEDs of the light ring will illuminate solid red.
- The engine will not crank.

Reconnect the wire or replace the starter solenoid to enable the machine to start.

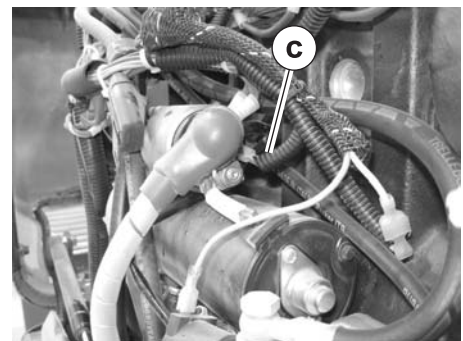
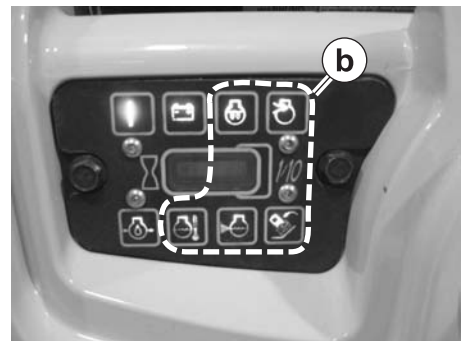
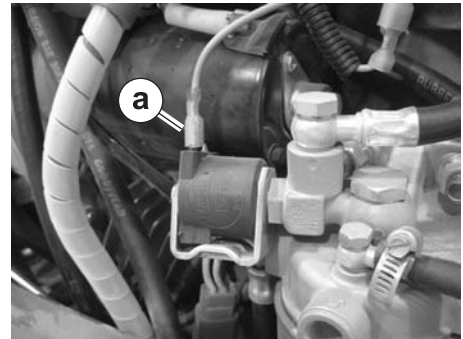

wc\_gr006333

### 4.30 Connecting the Diagnostic Tool

Use the diagnostic tool to access the diagnostic capabilities of the Engine Control Module (ECM).

To connect the diagnostic tool:

1. Shut down the machine.
2. Open the engine compartment.
3. Remove the cap from the connector **(b)** on the wiring harness.
4. Plug the diagnostic tool **(a)** into the wiring harness.

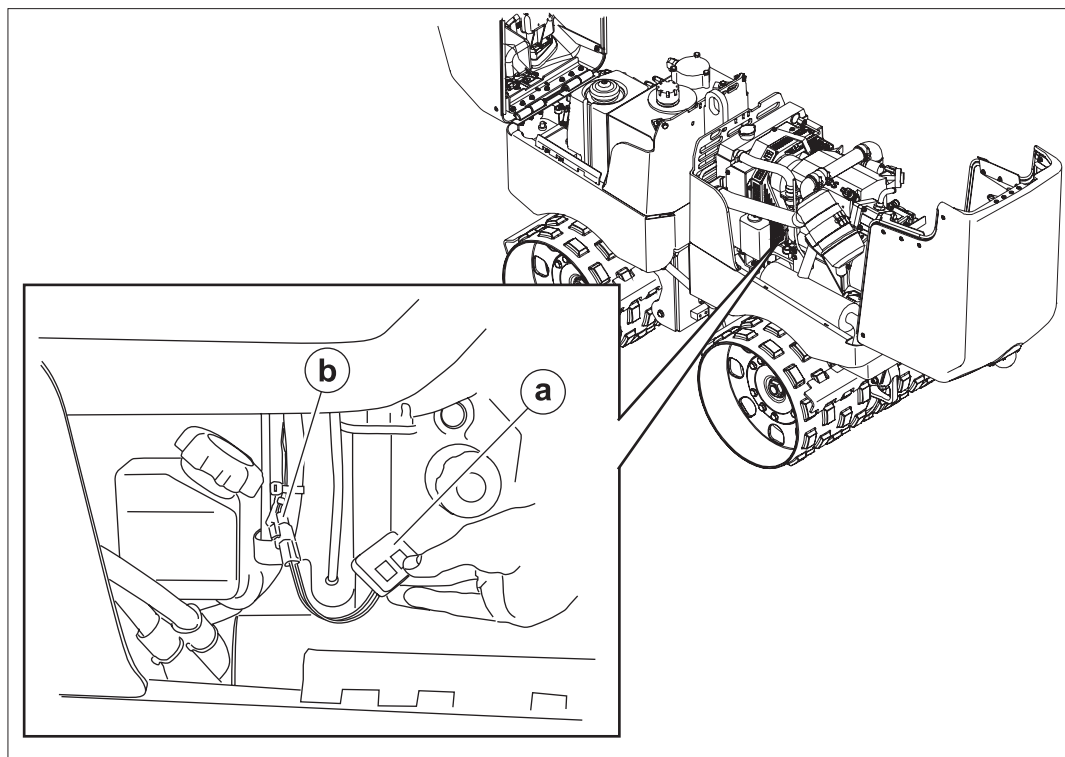

wc ar005055

### 4.31 Programming the ECM Tip-Over Mode

To set the ECM tip-over mode:

1. Connect the diagnostic tool. See section *Connecting the Diagnostic Tool*.

2. Do one of the following:

- Press and hold button "A" of the diagnostic tool and turn the key to ON. This will set the ECM to the FLASH LED mode.

or

- Press and hold both of the buttons of the diagnostic tool and turn the key ON. This will set the ECM to the LOCK OUT START mode.

3. Check the mode setting by observing the LED display of the ECM during the 5 seconds immediately after turning the key ON.

"L\_O" = LOCK OUT START

"F\_L" = FLASH LED

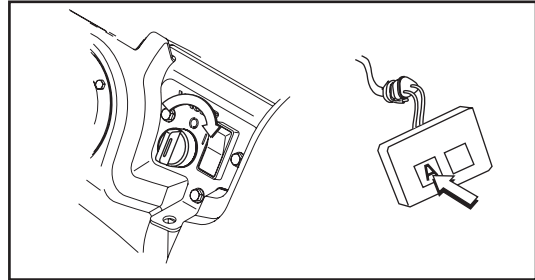

wc\_gr005052

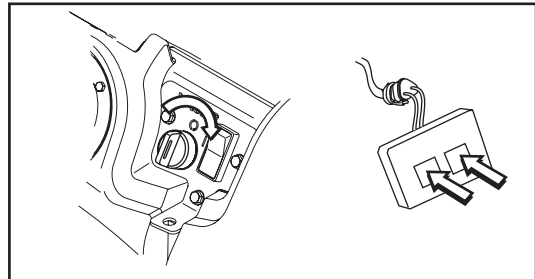

wc\_gr005051

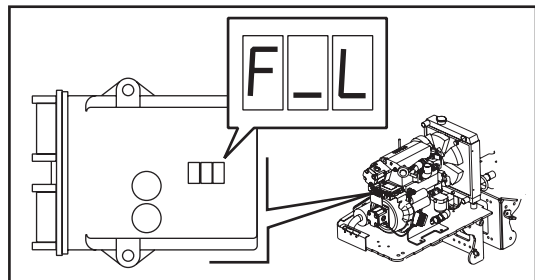

wc\_gr005050

### 4.32 Entering the ECM Diagnostic Mode

Perform the procedure below to enter the ECM diagnostic mode.

1. Begin with the key **(a)** in the OFF position.

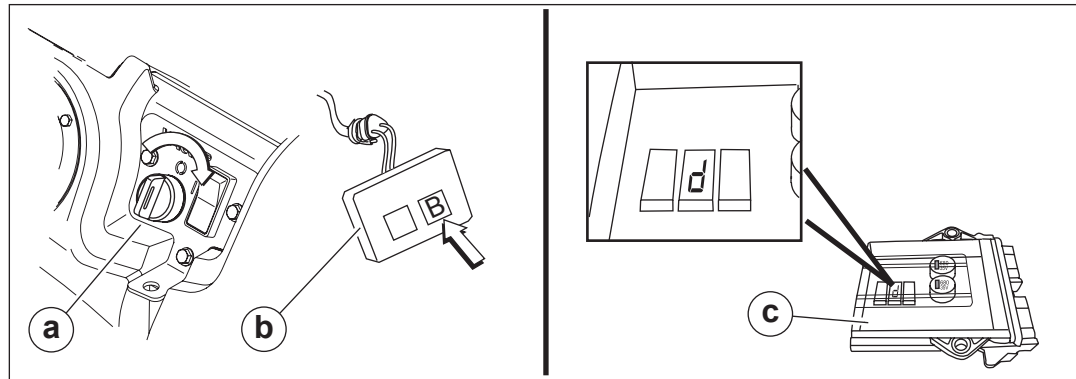

wc\_gr010575

2. Connect the diagnostic tool **(b)**. See topic *Connecting the Diagnostic Tool*.
3. Press and hold button "B" of the diagnostic tool. While holding button "B," turn the key to the ON position. Release button "B" when the letter "d" appears on the ECM **(c)**. The ECM diagnostic mode is now active.
4. Refer to the following topics for specific diagnostic procedures:
  - *ECM Fault and Error Codes*
  - *Resetting the ECM Diagnostic Data and the Tip-Over Light*

To exit the ECM diagnostic mode, turn the key to the OFF position.



### 4.33 ECM Fault and Error Codes

**Background** Machine fault and error codes are viewable on the three LED displays of the ECM. The tip over fault is always viewable after engine start. To view all other fault and error codes, the diagnostic mode of the ECM must be entered and the diagnostic tool must be connected.

**Fault codes** Each fault code consists of two sets of digits. The first set includes the letter “F” and represents the type of fault. The second set represents the number of times the fault has occurred or the time elapsed since the ECM has been cleared. **Note:** *All fault codes are displayed, even if there has not been a fault.* The fault codes scroll across the three LED displays automatically.

Fault code examples:

- “F00-02” — the roller has tipped over two times since the codes were cleared.
- “F06-0024” — the starter has been engaged 24 times since the codes were cleared
- “F07-120.0 H” — the roller has accumulated 120 hours since the codes were cleared.

**Error codes** Each error code consists of one set of digits. Each includes the letter “E” and represents the type of error. **Note:** *Only codes for those errors that have occurred are displayed.* The error codes are displayed as fixed characters—they do not scroll across the LED displays automatically.

Error code example:

- “E07” — the oil pressure sensor is or has been unplugged.

#### Viewing

Follow the procedure below to view the fault and error codes.

1. Connect the diagnostic tool. See section *Connecting the Diagnostic Tool*.
2. Enter the diagnostic mode of the ECM. See section *Entering the ECM Diagnostic Mode*.
3. Use the buttons on the diagnostic tool to cycle through the codes. Pressing the “A” button of the diagnostic tool advances through the codes. Pressing the “B” button cycles through the codes in the opposite order.
4. The fault codes (F00 to F07) are displayed first followed by the error codes (E00 to E39). Pressing the buttons of the diagnostic tool cycles through the error codes and back to the fault codes.

Code	Description
F00	Number of tip faults
F01	Number of over heat faults
F02	Number of low oil pressure faults
F03	Number of eeprom faults (ECM memory fault)
F04	Number of over voltage faults
F05	Run time under restricted air flow
F06	Number of starts
F07	Engine run time

Code	Description
E00	Possible bad glow time sensor
E01	Possible bad temperature sensor
E02	Possible bad air flow sensor
E03	Possible bad oil pressure sensor
E04	Possible bad tip sensor
E05	Temperature sensor was unplugged
E06	Air restriction sensor was unplugged
E07	Oil pressure sensor was unplugged
E08	Open starter solenoid
E09	Open fuel solenoid
E10	Open throttle hold solenoid
E11	Open throttle pull relay
E12	Open glow plug relay
E13	Open RX power relay
E14	Open LED ring output
E15	Low battery
E16	Starter solenoid
E17	Shorted fuel solenoid
E18	Shorted throttle hold solenoid
E19	Shorted throttle pull relay
E20	Shorted glow plug relay coil
E21	Shorted RX power relay coil
E22	Shorted LED ring output
E23	High oil pressure on power up
E24	Starter solenoid over current
E25	Fuel solenoid over current
E26	Throttle hold solenoid over current
E27	Throttle pull relay coil over current
E28	Glow plug relay coil over current
E29	RX power relay coil over current
E30	LED ring output over current
E31	Open
E32	High starter solenoid current
E33	High fuel solenoid current
E34	High throttle hold solenoid current
E35	High throttle pull relay coil current
E36	High glow plug relay coil current
E37	High RX power relay coil current
E38	High LED ring output current
E39	Open

### 4.34 Resetting the ECM Diagnostic Data and the Tip-Over Light

To reset the ECM diagnostic data, and turn off the tip-over light (**h**), carry out the following procedure.

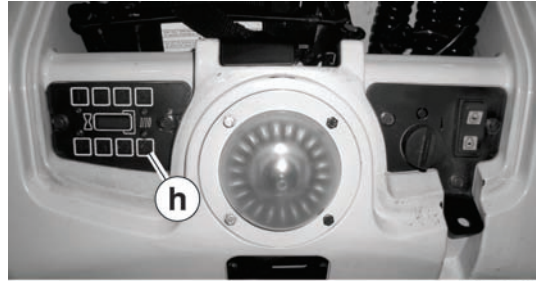

wc\_gr005057

5. Connect the diagnostic tool. See section *Connecting the Diagnostic Tool*.
6. Enter the diagnostic mode of the ECM. See section *Entering the ECM Diagnostic Mode*.

**Note:** Before proceeding, it is important to realize all stored data will be erased.

7. While in the diagnostic mode, press and hold both buttons of the diagnostic tool for approximately 5 seconds and observe the ECM LED displays.

The ECM LED displays will change to nine dashes once the ECM has been reset.

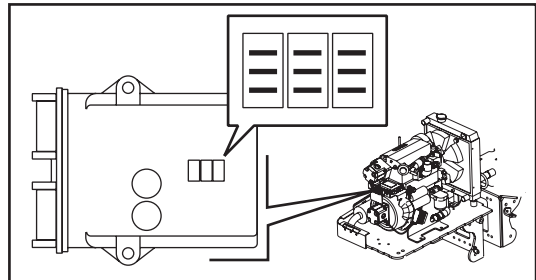
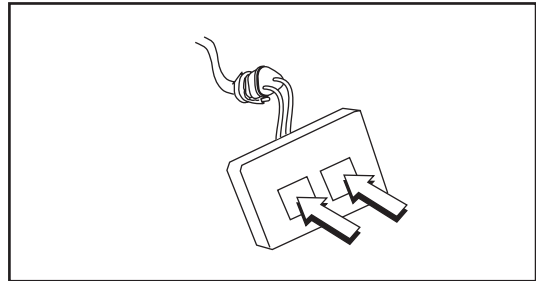

wc\_gr005049

### 4.35 Calibrating the Joysticks

To determine if calibration is needed, press and release the red ON/OFF pushbutton (j).

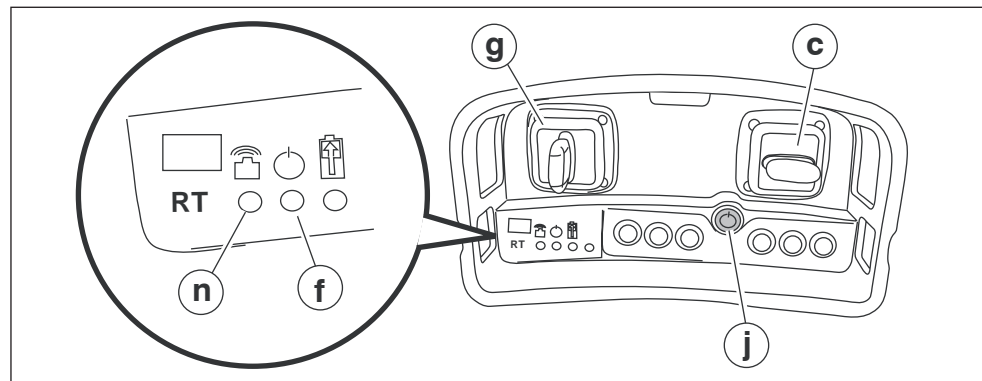

wc\_gr010840

- If the joysticks are out of calibration, the signal transmission indicator (n) will illuminate red and remain lit, and the operating status indicator (f) will blink.
- If the joysticks are calibrated, the signal transmission indicator will remain dark, and the operating status indicator will blink.

#### Calibration procedure

All four joystick positions must be calibrated before the transmitter can return to its normal operating mode. Perform the procedure below to calibrate the joysticks.

1. Press and release the ON/OFF pushbutton to power up the transmitter.
2. Press and hold the ON/OFF pushbutton for approximately 3 seconds until the operating status indicator illuminates and remains lit. Release the ON/OFF pushbutton.
3. Press and hold the ON/OFF pushbutton again for approximately 3 seconds until the operating status indicator flashes rapidly. Release the ON/OFF pushbutton.
4. Move the forward/reverse joystick (c) all the way forward and hold it in place. While holding the joystick, press and release the ON/OFF pushbutton—the signal transmission indicator will flash. Release the forward/reverse joystick.
5. Move the forward/reverse joystick all the way backward and hold it in place. While holding the joystick, press and release the ON/OFF pushbutton—the signal transmission indicator will flash. Release the forward/reverse joystick.

*This procedure continues on the next page.*

*Continued from the previous page.*

6. Move the left/right joystick (**g**) all the way to the left and hold it in place. While holding the joystick, press and release the ON/OFF pushbutton—the signal transmission indicator will flash. Release the left/right joystick.
7. Move the left/right joystick all the way to the right and hold it in place. While holding the joystick, press and release the ON/OFF pushbutton—the signal transmission indicator will flash. Release the left/right joystick.

**Result**

The joysticks have now been calibrated.

**Exiting calibration mode**

---

The transmitter will automatically return to its normal operating mode after joystick calibration.

**Note:** *If you are unable to exit calibration mode, remove and re-install the transmitter battery. This will reset the system.*

## 5 Changing Drums (RTx)

### 5.1 Removing the Drum Extensions

**Introduction** RTx machines are factory-equipped with four drum extensions; one attached to each drum. The overall width of the drums with extensions is 820 mm (32 in). By removing the drum extensions, the user can decrease the overall width of the drums to 560 mm (22 in.) as needed to accommodate specific job requirements.

- Requirements**
- Engine stopped; machine cool to the touch
  - Metric hand tools (sockets, wrenches, etc.)
  - Torque wrench
  - Narrow scrapers
  - Loctite 243 or equivalent

**Procedure** Perform the procedure below to remove the drum extensions.

1. Remove the three screws (**g**) and washers (**h**) and remove the wide scraper (**a**). Keep the screws (**g**) and washers (**h**) for installation of the narrow scraper described at the end of this procedure.

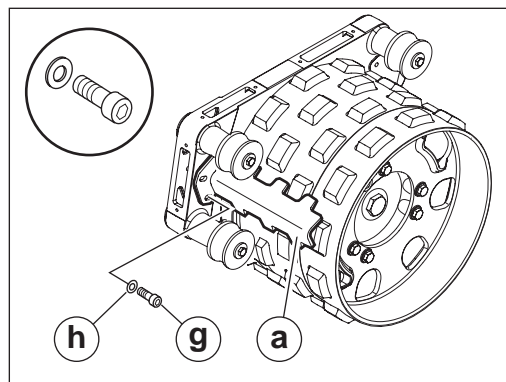

wc\_gr010670

2. Remove the three M16 x 25 screws (**c**).

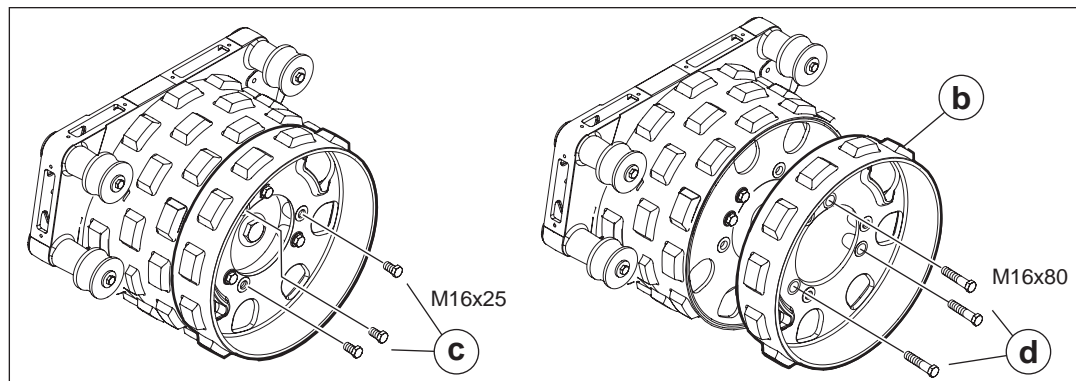

wc\_gr010666

3. Remove the three M16 x 80 screws (**d**) and remove the drum extension (**b**).

*This procedure continues on the next page.*

Continued from the previous page.

4. Install the three M16 x 80 screws (**d**) into the threaded holes of the drum extension. (Use the holes where the M16 x 25 screws were installed.) Place the drum extensions, with screws installed, in storage for future use.

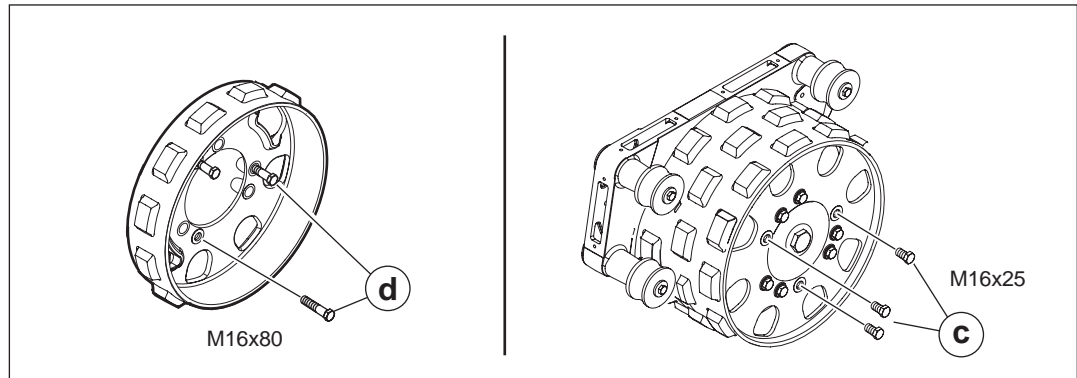

wc\_gr010671

5. Install the M16 x 25 screws (**c**) to the drum in the locations shown. Use Loctite 243 or equivalent on the screws and torque them to 210 Nm (123 ft.lbs.).
6. Install the narrow scraper (**f**) using the screws (**g**) and washers (**h**) from step 1. Use Loctite 243 or equivalent on the screws and torque them to 86 Nm (63 ft.lbs.).

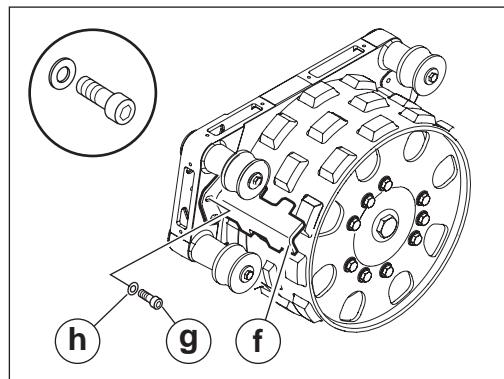

wc\_gr010672

7. Repeat the procedure for each drum.

## Result

The drum extensions have now been removed.

## 5.2 Installing Drum Extensions

**Introduction** The overall width of the drums on the RTx is 560 mm (22 in.). By installing drum extensions, the user can increase the overall width of the drums to 820 mm (32 in.) as needed to accommodate specific job requirements.

- Requirements**
- Engine stopped; machine cool to the touch
  - Metric hand tools (sockets, wrenches, etc.)
  - Torque wrench
  - Drum extensions and mounting hardware
  - Wide scrapers and mounting hardware

**Installing the drum extensions** Perform the procedure below to install the drum extensions.

1. Remove the narrow scraper (**f**) from the front drum. Place the scraper in storage for future use, but keep the screws (**g**) and washers (**h**) available. You will re-use the screws and washers to install the wide scraper at the end of this procedure.

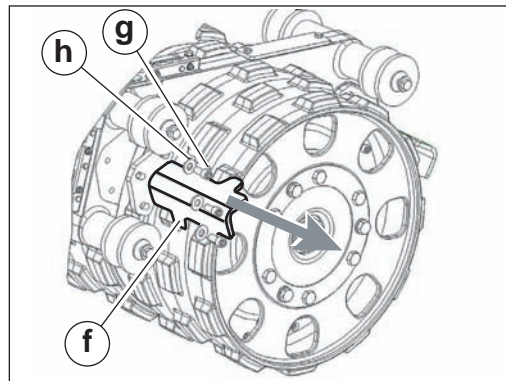

wc\_gr009889

*This procedure continues on the next page.*



Continued from the previous page.

- Remove (3) M16 x 25 screws (c) from each end of the front drum as shown.

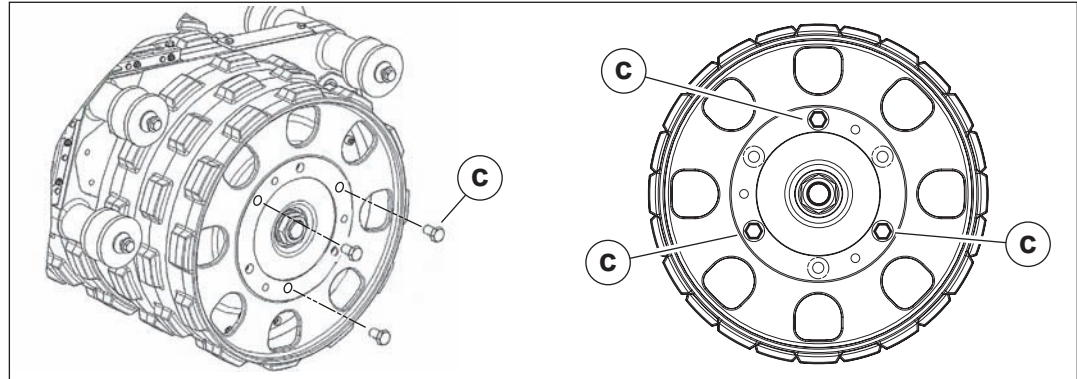

wc\_gr010011

- Install a drum extension (b) on each end of the front drum. Align the mounting holes as shown in view "A" below.

**Note:** As you align the mounting holes, make sure the "sheep's foot" lugs on the drum and drum extension are offset from one another.

- Fasten the drum extension with (3) M16 x 80 screws (d) in the locations shown in views "A" and "B" below. Torque to 167 Nm (123 ft.lbs.).

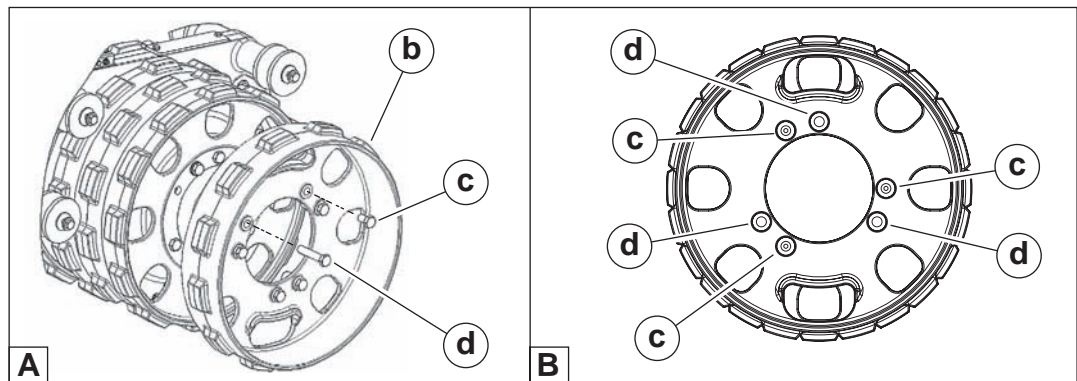

wc\_gr009890

- Store (3) M16 x 25 screws (c) in the threaded "placeholder" holes as shown.

*This procedure continues on the next page.*

*Continued from the previous page.*

6. Install the wide scraper **(a)** using the screws **(g)** and washers **(h)** from Step 1. Torque the screws to 98 Nm (72 ft.lbs).

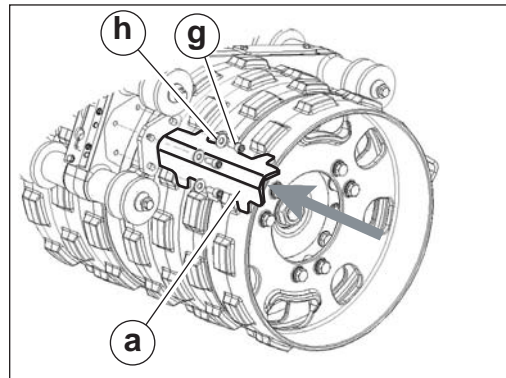

wc\_gr009892

7. Repeat the installation procedure on the rear drum, beginning with Step 1.

---

## Result

The drum extensions have now been installed.

## 6 Maintenance

### 6.1 Break-in Period

Perform initial oil and filter changes as listed below. Follow *Periodic Maintenance Schedules* thereafter.

1. Change engine oil and replace oil filter after first 50 hours.
2. Replace hydraulic return line filter after first month or 100 hours.

### 6.2 Periodic Maintenance Schedule

The table below lists basic machine maintenance. Tasks designated with check marks may be performed by the operator. Tasks designated with square bullet points require special training and equipment.

Roller	Daily before starting	Every 100 hrs.	Every 500 hrs. or 1 year	Every 1000 hrs. or 2 Years
Check for loose or missing fasteners. Replace as needed.	✓			
Check hydraulic oil. Fill to correct level.	✓			
Clean control box / transmitter.	✓			
Verify that receiving eyes blink rapidly when approached by the operator.	✓			
Grease articulated joint.		✓		
Grease steering cylinder.		✓		
Change hydraulic system return line filter. <sup>1</sup>			■	
Change hydraulic fluid.				■

<sup>1</sup> Change after the first 100 hours of operation.

The table below lists basic engine maintenance. Tasks designated with check marks may be performed by the operator. Tasks designated with square bullet points require special training and equipment.

Refer to the engine manufacturer's owner's manual for additional information.

Kohler Engine	Daily before starting	Every 100 hrs.	Every 125 hrs.	Every 250 hrs.	Every 300 hrs.	Every 500 hrs.
Check engine oil. Fill to correct level.	✓					
Replace air filter if indicator light is on.	✓					
Check condition and tension on fan belt.	■					
Clean engine head and cylinder fins.		■				
Change oil in engine crankcase.			■			
Replace engine oil filter.				■		
Check and adjust fan belt.				■		
Replace fuel filter cartridge.				■		
Clean injectors and check injector pressure.					■	
Replace fan belt.						■
Check valve clearance.						■

## 6.3 Hydraulic Oil Requirements

Wacker Neuson recommends the use of a good petroleum-based, anti-wear hydraulic oil in the hydraulic system of this equipment. Good anti-wear hydraulic oils contain special additives to reduce oxidation, prevent foaming, and provide for good water separation.

When selecting hydraulic oil for your machine, be sure to specify anti-wear properties. Most hydraulic oil suppliers will provide assistance in finding the correct hydraulic oil for your machine.

Avoid mixing different brands and grades of hydraulic oils.

Most hydraulic oils are available in different viscosities.

The SAE number for an oil is used strictly to identify viscosity—it **does not** indicate the type of oil (engine, hydraulic, gear, etc.).

When selecting a hydraulic oil be sure it matches the specified SAE viscosity rating and is intended to be used as a hydraulic oil. See section *Technical Data—Lubrication*.

## 6.4 Hydraulic Oil Level

A hydraulic oil level sight gauge **(c)** is located on the hydraulic tank inside the rear section of the machine.

While the machine is turned off, check that the hydraulic oil level is visible at the middle level or higher in the sightglass. If it is not, add oil as required through the filter housing on top of hydraulic tank. Use only clean hydraulic oil.

Thoroughly clean the top of the filter cover **(d)** before removing it from the tank. Care should be taken to prevent small dirt particles from entering the system.

**NOTICE:** If hydraulic oil continually needs to be added, inspect hoses and connections for possible leaks. Repair hydraulic leaks immediately to prevent damage to hydraulic components.

## 6.5 Changing Hydraulic Oil and Filter

**Note:** *In the interests of environmental protection, place plastic sheeting and a container under the machine to collect the liquid which drains off. Dispose of this liquid properly.*

To change hydraulic oil:

1. Remove the drain plug from bottom of frame and allow hydraulic fluid to drain.
2. Clean the filter cover **(d)**.
3. Remove the filter cover, and remove the filter element **(a)** and lower filter housing **(e)**.

**Note:** *As you remove the filter element and lower filter housing, take care to note the proper location of all sealing O-rings.*

**NOTICE:** To avoid machine damage, be extremely careful to avoid dropping anything into filter housing **(b)** while the filter cover is off.

4. Re-install the drain plug.
5. Fill hydraulic tank through filter housing **(b)** using clean hydraulic fluid.
6. Install new filter element **(a)** as shown in illustration.
7. Replace the O-rings, lower filter housing, and filter cover.

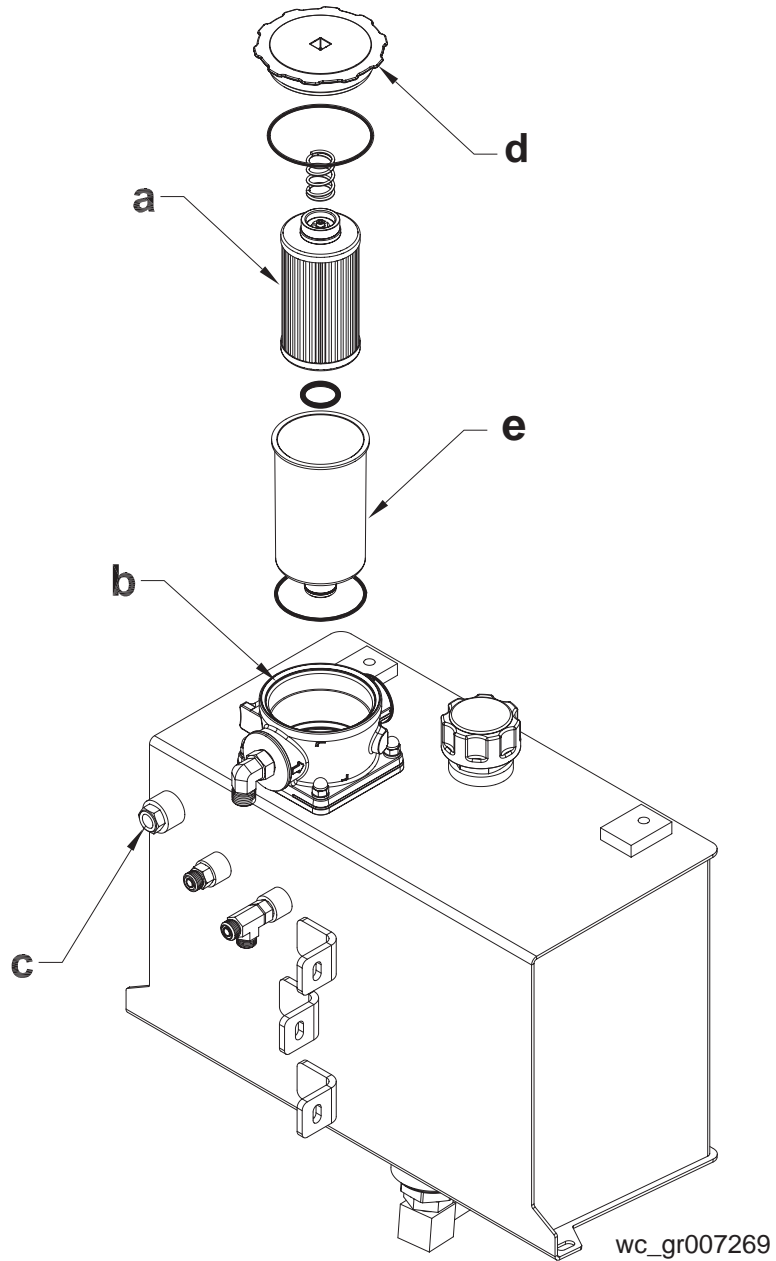

## 6.6 Articulated Joint and Steering Cylinders

Lubricate top and bottom bearing blocks **(a)** and cylinder knuckles **(b)** every 100 hours using a hand-held grease gun. Cylinder knuckles can be accessed through holes on side of machine **(c)**.

Use Mobil XHP222 or an equivalent No. 2 general purpose grease.

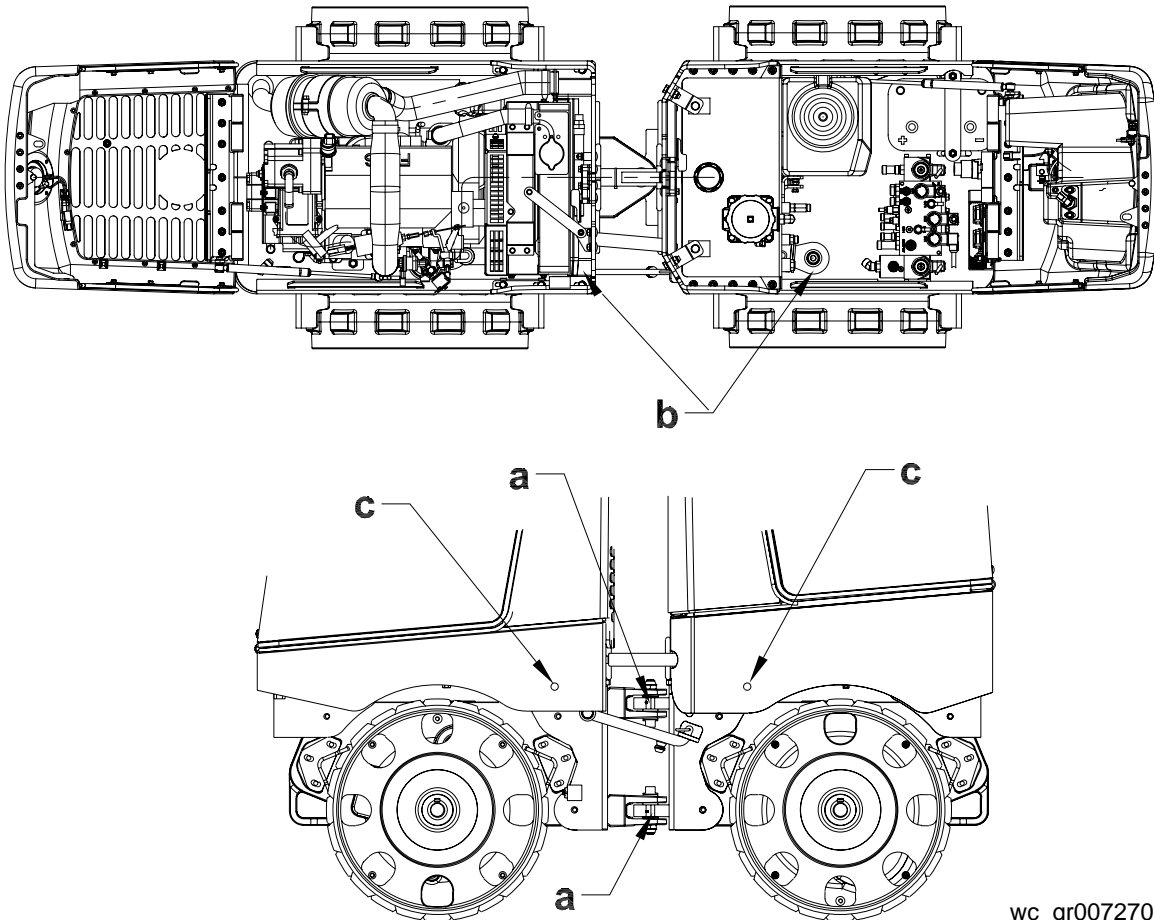

wc\_gr007270

## 6.7 Cleaning SmartControl™ Transmitter

The transmitter and switches are completely sealed to keep dust and moisture out; however, contact with water should be kept to a minimum. Even a small amount of moisture can cause connections and contacts to corrode. Avoid immersing transmitter in water and do not clean using a pressure wash.

To clean the transmitter:

1. Wash off the transmitter using a damp cloth. Allow it to air dry.
2. To remove dirt and dust trapped around switches, use low-pressure compressed air.

## 6.8 Scraper Bars

Scraper bars are provided on all four drums to prevent dirt from building up on the drum surfaces. These scrapers should be inspected and adjusted as required to remove as much dirt from the drums as possible.

To adjust a scraper:

Loosen the three screws (**a**) holding each scraper to the drum casting. Position the scraper 3–6 mm (1/8–1/4 in.) from the drum. Tighten screws and run machine to check that the scraper does not rub against the drum surface.

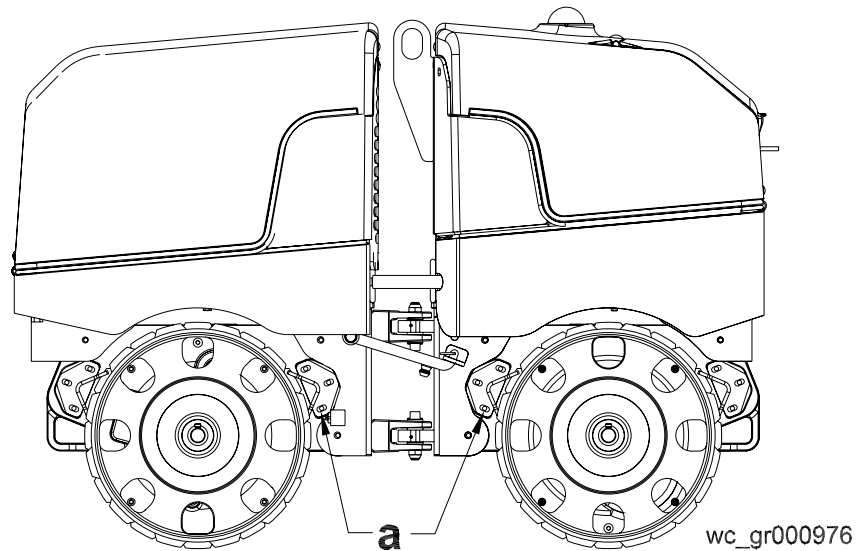



## 6.9 Shock Mounts

Inspect the drum shockmounts (**a**) every 300 hours for cracking, splitting or tearing. Replace shockmounts as needed.

**NOTICE:** The shockmounts isolate the upper part of the machine from the heavy vibrations produced in the drums. Operating the machine with damaged shockmounts for an extended period of time may eventually damage other machine parts.

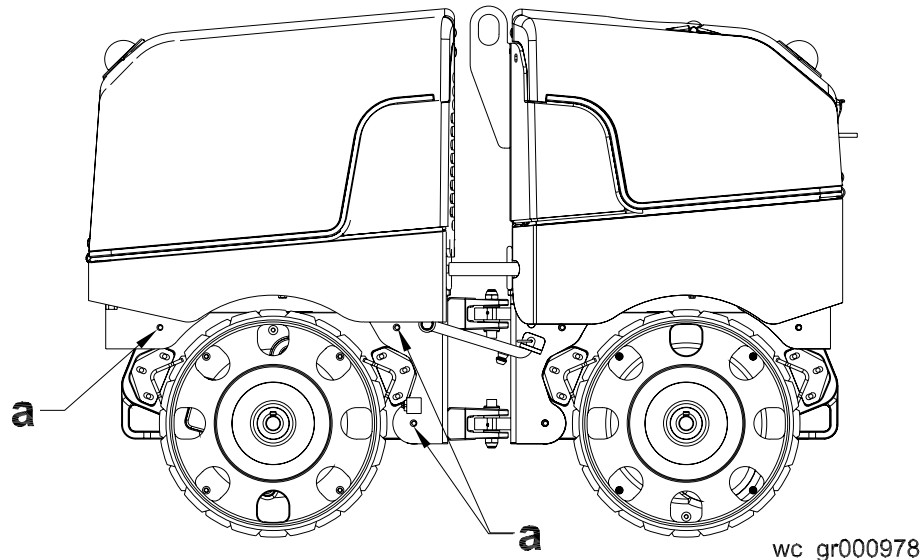

## 6.10 Battery

The battery supplied on this machine is rated at 12V with 800 Amp cold cranking capacity. It features a sealed, ventless design, and is constructed to resist vibration and provide longer service life.



DO NOT use automotive-type batteries on this machine. Automotive-type batteries are not designed to withstand the heavy vibration produced by this machine. The case on automotive-type batteries could fail, causing battery acid to leak.

Inspect battery periodically. Keep battery terminals clean and connections tight.

Maintain the battery at full charge to improve cold weather starting.

**NOTICE:** Observe the following to prevent serious damage to the machine's electrical system:

- Never disconnect the battery with the machine running.
- Never attempt to run the machine without a battery.
- Never attempt to jump-start a machine.
- In the event that the machine has a dead battery, either replace the battery with a fully charged battery or charge the battery using an appropriate battery charger.



Explosion hazard. Batteries can emit explosive hydrogen gas. Keep all sparks and flames away from the battery. Do not short-circuit battery posts. Do not touch the machine frame or the negative terminal of the battery when working on the positive terminal.

## 6.11 Lubrication

Check the engine oil level daily. Add oil as required.

### To check oil:

Place the machine on a level surface, remove the dipstick and check that the oil level is at the top mark. Add oil through the oil filler cap (a) on top of engine, checking occasionally with dipstick; DO NOT overfill.

### Suggested oil grades:

Use only diesel engine oil API service rating CF or equivalent.

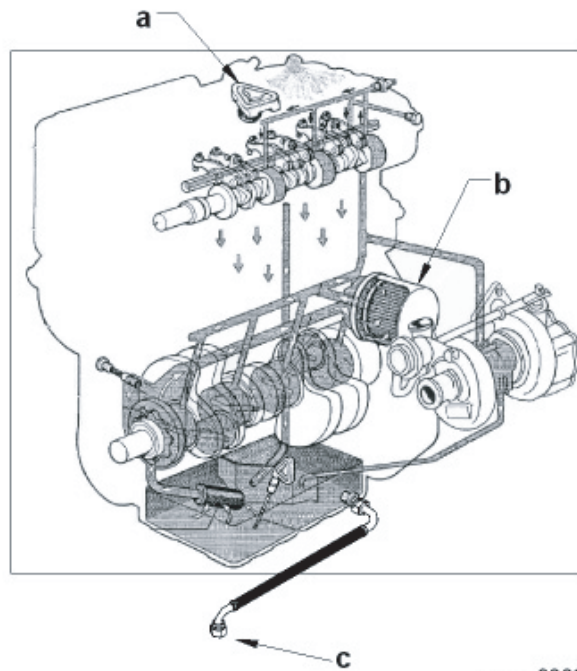

wc\_gr000971

## 6.12 Engine Oil and Filter

Change oil every 125 hours and oil filter **(b)** every 250 hours. On new machines, change oil after first 50 hours of operation. Drain oil while engine is still warm.

**Note:** *In the interests of environmental protection, place plastic sheeting and a container under the machine to collect the liquid which drains off. Dispose of this liquid properly.*

### To change oil:

1. Remove oil filler cap **(a)** and oil drain plug **(c)**. Drain oil into a suitable container.
2. Reinstall the drain plug and tighten.
3. Remove and replace oil filter **(b)**.
4. Remove oil filler cap **(a)** and fill engine crankcase with recommended oil. See *Technical Data* for oil quantity and type.
5. Install oil filler cap.



### WARNING

Most used oil contains small amounts of materials that can cause cancer and other health problems if inhaled, ingested, or left in contact with skin for prolonged periods of time.

- ▶ Take steps to avoid inhaling or ingesting used engine oil.
- ▶ Wash skin thoroughly after exposure to used engine oil.

## 6.13 Servicing the Air Cleaner

Replace both air filter elements when the air filter warning light illuminates. See Section *Control Panel Features*.

The air cleaner assembly contains a primary air filter element **(a)** and a secondary air filter element **(f)**.

To replace the air filter elements:

1. Remove the end cover **(b)**, then discard both filter elements.
2. Insert new air filter elements, then:
3. Re-install the end cover, making sure that the dust cap **(c)** is clean and is pointing downward.

Periodically, make sure the inlet pipe **(d)** is free from obstructions.

**NOTICE:** *Check all connections and make sure they are snug. An air leak at the neck clamp or intake pipe can quickly lead to expensive engine repairs.*

- Make sure that the intake piping **(e)** is fully engaged over the neck of the filter to ensure a good seal.
- If the filter housing, neck, or inlet pipe are crushed or damaged, replace them immediately.

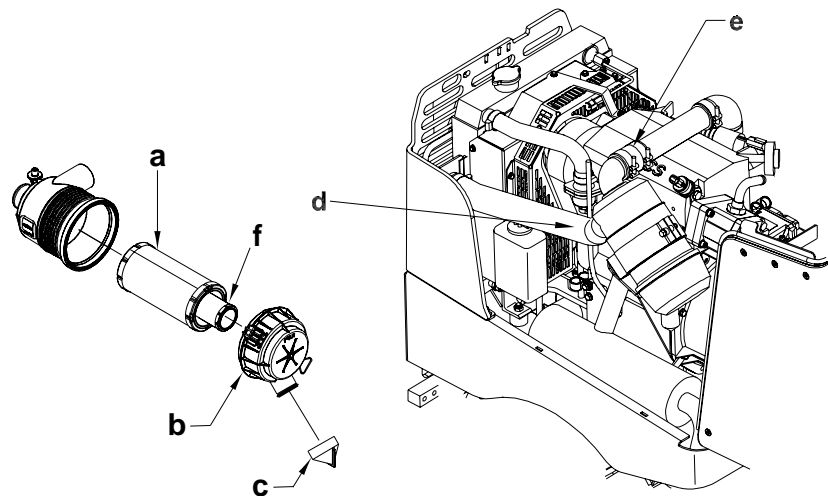

wc\_gr005166

## 6.14 Engine Fuel Delivery System Maintenance

Maintenance to the engine fuel delivery system should be performed by an experienced mechanic familiar with diesel engines. For detailed maintenance procedures on the engine fuel system, refer to the engine manual supplied with the machine at the time of shipment.

## 6.15 Maintaining the Fuel Filter

Change engine fuel filter every 300 hours of operation.

### To change fuel filter:

4. Remove filter **(a)** from engine block.
5. Install new filter. If necessary, prime fuel lines as described in *Priming the Fuel System*.

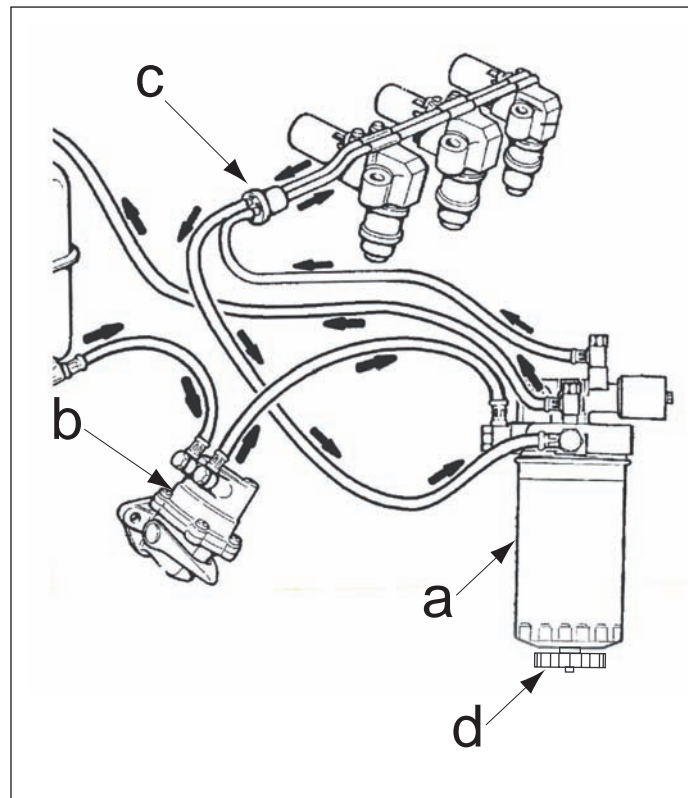

wc\_gr007280

## 6.16 Draining the Fuel Filter Water Separator

**Procedure** Follow the procedure below to drain the fuel filter water separator.

1. Place a suitable collection container beneath the fuel filter **(a)**.
2. Loosen the cap **(d)** on the bottom of the fuel filter. This allows water and sediment to drain through the hole in the cap.
3. Tighten the cap.
4. Carefully remove the collection container and dispose of the contents in accordance with local environmental regulations.

## 6.17 Priming the Fuel System

If the fuel tank has been run completely dry or drained for service, it will be necessary to manually prime the fuel system.

**To prime the fuel system:**

1. Turn both the key switch on the machine, and the on-off switch on control box, on. This will open the fuel valve.
2. Loosen the bleed screw on the fuel filter and pump the lever on the fuel pump **(b)** until fuel flows freely from the bleed screw. Tighten the bleed screw.
3. Repeat this procedure for the fuel line bleed screw **(c)**.

## 6.18 Engine Coolant

Check the coolant level of the radiator daily while the engine is cold. The coolant level should be at the cold level mark (lower line) on the overflow bottle. Add coolant in a 50% water/50% glycol mixture if required.



**WARNING**

NEVER remove the radiator cap or drain plug while the engine is hot! Pressurized coolant can cause serious burns.

If it is necessary to open the radiator, only do so with the engine off, and only when coolant is cool enough to touch with bare hands. Slowly loosen cap to relieve pressure first, before removing it completely.

## 6.19 Adjusting Valve Clearance

Check and adjust valve clearance every 500 hours. Set clearance with engine cold. Replace the valve/rocker arm cover gasket when checking the valve clearances. Refer to the engine manufacturer's service manual for detailed information.

### To adjust valve clearances:

1. Remove valve/rocker arm cover
2. Bring each cylinder piston to top dead center on the compression stroke and set clearance.
3. Valve clearance **(A)**: 0.20mm (0.008 in.). Valve clearance **(B)**: 0.15mm (0.006 in.).
4. Clean gasket material from cylinder head.
5. Place a small bead of RTV Silicone on cylinder head to secure ends of new gasket. Gently place gasket on cylinder head.
6. Replace valve/rocker arm cover. Torque bolts to 9 Nm (7 ft.lbs.).

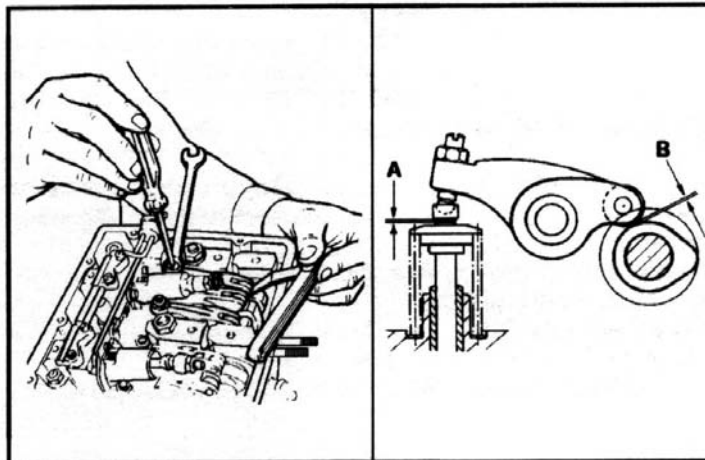

wc\_gr002366

## 6.20 Adjusting the Fan Belt

1. Remove the hydraulic oil cooler.
2. Remove radiator and shroud.
3. Remove the four screws **(a)** securing the fan to the engine and remove the fan.
4. Remove the outer pulley plate **(b)**.
5. Insert the appropriate amount of shims **(c)** to give you the required tension on the belt. The fewer the number of shims, the tighter the belt will be. Approximately 6–12 mm (1/4–1/2 in.) deflection is recommended.
6. Place unused shims between outer pulley plate and fan when reinstalling the fan. Secure the fan to the engine with the four screws **(a)**.

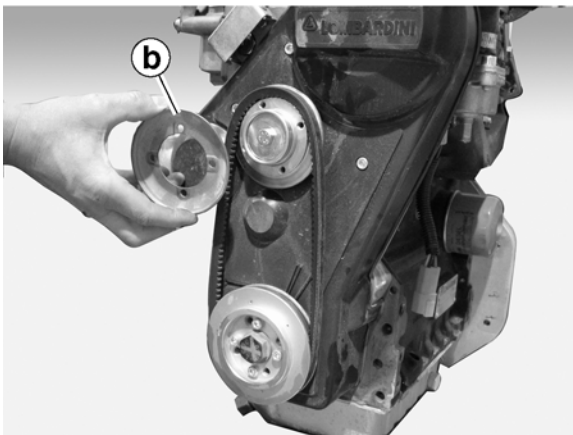
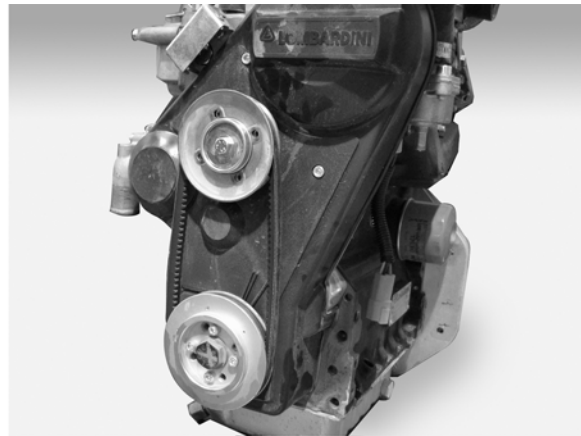
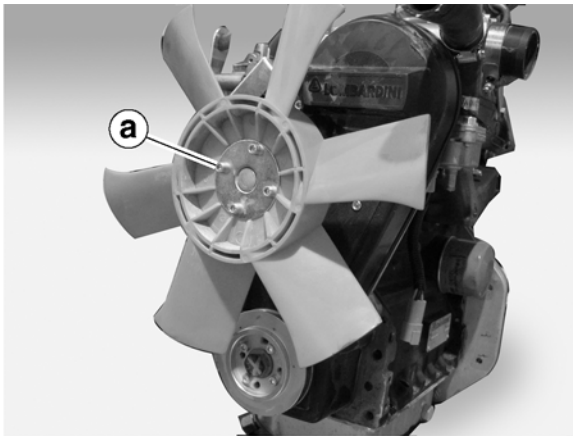

wc\_gr002377



## 6.21 Storage

Never allow the roller to sit overnight in a ditch, trench or other low-lying area which might fill with water during a heavy rain. Park the roller on a flat level surface, out of the way of traffic patterns and congestion. If the roller must be parked on an incline, chock the drums to prevent any chance of movement.

If leaving the roller on the job site, remember to remove the key and lock the control panel cover and engine hood to prevent tampering. Both the front and rear hoods and access cover are equipped with a locking ring (**a**) for use with a padlock for this purpose.

If desired, the SmartControl™ can be removed from the roller and stored separately.

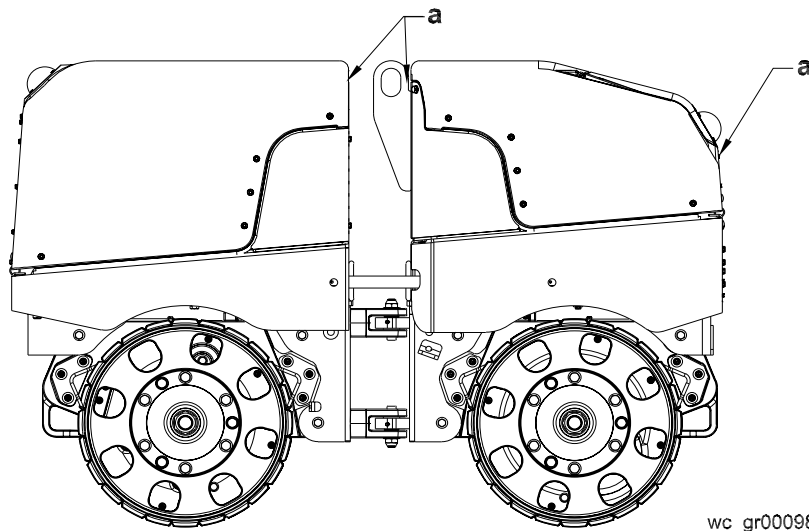

wc\_gr000983

## 6.22 Long-Term Storage

If storing unit longer than 30 days, the following steps are recommended:

1. Change the engine oil.
2. Clean or change air cleaner elements.
3. Drain any water that may have collected at the bottom of the fuel tank. Replace the fuel filter. Refill the tank with fresh No. 2 diesel fuel.

**Note:** Diesel fuel is subject to bacterial growth which can contaminate fuel lines. Allowing the tank to sit dry for a long period of time helps promote such growth. The addition of a biocide to the fuel is recommended to inhibit bacterial growth and protect the engine fuel system.

4. Store the unit indoors in a clean dry area. If the unit must be stored outdoors, cover it.

## 6.23 Machine Disposal / Decommissioning

**Introduction** This machine must be properly decommissioned at the end of its service life. Responsible disposal prevents toxic chemicals and materials from harming the environment. This machine contains several components that may be considered hazardous waste in many areas:

- Operating fluids, including fuel, engine oil, grease, and hydraulic fluid
- Batteries
- Electronic components, such as circuit boards, control panels, LEDs, and joysticks

Before decommissioning this machine, read and follow local safety and environmental regulations pertaining to the disposal of construction equipment.

---

**Preparation** Perform the following tasks to prepare the machine for disposal.

- Move the machine to a protected location where it will not pose any safety hazards and cannot be accessed by unauthorized individuals.
- Ensure that the machine cannot be operated from the time of final shutdown to disposal.
- Drain all fluids, including fuel, engine oil, and hydraulic fluid.
- Seal any fluid leaks.
- Remove the battery.

---

**Disposal** Perform the following tasks to dispose of the machine.

- Disassemble the machine and separate all parts by material type.
- Dispose of recyclable parts as specified by local regulations.
- Dispose of all non-hazardous components that cannot be recycled.
- Dispose of waste fuel, engine oil, and hydraulic fluid in accordance with local environmental protection regulations.

## 7 Troubleshooting

Problem	Reason	Remedy
Engine does not start	Fuel tank empty	Fill with No. 2 diesel fuel and prime fuel lines.
	Wrong type of fuel	Drain tank, change fuel filter, and fill with fresh fuel.
	Water in fuel	Drain water from fuel filter.
	Old fuel	Drain tank, change fuel filter, and fill with fresh fuel.
	Fuel system not primed	Prime fuel system.
	Fuel filter restricted or clogged	Replace fuel filter.
	Battery connections loose or corroded	Check connections. Tighten or clean as needed.
	Discharged battery	Charge or replace battery.
	Engine oil level too low	Add engine oil.
	Air cleaner element clogged	Maintain air cleaner.
	Faulty starter motor	Repair or replace.
	Faulty starter button on control box or transmitter	Repair or replace.
	Inoperative fuel valve solenoids on engine	Repair or replace.
	Inoperative starter relay	Repair or replace.
	Electrical connections loose or broken	Check connections; repair or replace.
	Machine out of infra-red signal range	Move transmitter closer to machine.
Transmitter and decoder channels are different	Set transmitter and decoder to the same channel.	
Communication fault	See topic <i>Communication Faults</i> .	
Engine starts, then stops	Fuel tank empty	Fill with No. 2 diesel fuel and prime fuel lines.
	Fuel filter restricted or clogged	Replace fuel filter.
	Fuel lines broken or loose	Check fuel lines; tighten, repair or replace as needed
	Machine out of infra-red range.	Move transmitter closer to machine.
	Transmitter automatically powered off due to inactivity	Turn on transmitter.

Problem	Reason	Remedy
No vibration	Machine in high speed travel mode	Reduce machine speed, then press vibration switch.
	Faulty vibration switch or poor connection inside transmitter	Check connection; repair or replace as needed.
	Inoperative solenoid on vibration valve	Repair or replace.
	Damaged exciter assembly	Repair or replace.
	Damaged exciter motor coupling	Repair or replace.
	Damaged exciter motor	Repair or replace.
	Damaged exciter pump	Repair or replace.
	Machine out of infra-red signal range	Move transmitter closer to machine.
	Operator too close to machine	Move away from machine.
	Communication fault	See topic <i>Communication Faults</i> .
No travel, or travel only in one direction	Faulty forward/reverse switch or poor connection inside transmitter	Check connection; repair or replace as needed.
	Inoperative solenoid on travel valve	Repair or replace.
	Damaged drive gearcase assembly	Repair or replace.
	Loose, broken or corroded wire connections inside control panel or transmitter	Repair or replace.
	Damaged drive motor	Repair or replace.
	Damaged drive pump	Repair or replace.
	Machine out of infra-red signal range	Move transmitter closer to machine.
	Operator too close to machine	Move away from machine.
	Communication fault	See topic <i>Communication Faults</i> .
No high speed travel	Faulty forward/reverse switch or poor connection inside transmitter	Check connection; repair or replace as needed.
	Inoperative solenoid on manifold	Repair or replace.
	Loose, broken or corroded wire connections inside control panel or transmitter	Repair or replace.
	Damaged exciter pump	Repair or replace.
	Vibration is turned on	Turn off vibration.
	Machine out of infra-red signal range	Move transmitter closer to machine.
	Operator too close to machine	Move away from machine.
	Communication fault	See topic <i>Communication Faults</i> .

Problem	Reason	Remedy
No steering	Faulty left/right joystick switch or poor connection inside transmitter	Check connection; repair or replace as needed.
	Inoperative solenoid on steering valve	Repair or replace.
	Loose, broken or corroded wire connections inside control panel or transmitter	Repair or replace.
	Damaged steering cylinder	Repair or replace.
	Locking bar engaged	Disengage locking bar.
	Machine out of infra-red signal range	Move transmitter closer to machine.
	Operator too close to machine	Move away from machine.
	Communication fault	See topic <i>Communication Faults</i> .

**8 Technical Data**

**8.1 Engine**

**Engine Power Rating**

Net power rating per ISO 3046/1. Actual power output may vary due to conditions of specific use.

Item No.:		RT / RTx
Engine		
Engine Type		3-cylinder, 4-cycle, liquid-cooled, diesel engine
Engine Make		Kohler
Engine Model		KDW 1003
Rated Power	kW (Hp)	15.5 (20.8) @ 2600 rpm
Emission standard category		Tier 4
Alternator	Amp / V	23.8 / 16.5 @ 2600 rpm
Engine Speed - full load	rpm	2600
Engine Speed - idle	rpm	1300
Valve Clearance (cold) intake: exhaust:	mm (in.)	0.15 (0.006) 0.20 (0.008)
Air Cleaner	type	Dry pleated paper elements
Battery	V / CCA	12V - Sealed / 800
Fuel	type	No. 2 Diesel Low sulfur or ultra low sulfur fuel only
Fuel Tank Capacity	l (gal.)	18.9 (6.3)
Fuel Consumption	l (gal.)/hr.	4.5 (1.2)
Radiator Capacity	l (gal.)	4.75 (1.25)

## 8.2 Roller

Item No:		RT x		RT 82SC-2
		Narrow	Wide	—
Operating Weight	kg (lb.)	1428 (3148)	1560 (3439)	1473 (3247)
Area Capacity	m <sup>2</sup> (ft <sup>2</sup> ) / hr.	676 (7276)	990 (10654)	972 (10560)
Inside Turning Radius	m (in.)	1.73 (68)	1.6 (63)	1.6 (63)
Travel Speed	m (ft.)/min.	41.66 (132) high 21.66 (66) low		
Vibration Frequency	Hz (vpm)	41.7 (2500)		
Gradeability with Vibration	%	50		
Gradeability w/o Vibration	%	45		

## 8.3 Lubrication

Item No:		RT / RTx
Lubrication		
Engine Crankcase	type l (qt.)	SAE 15W40 Class CF rated 2.5 (2.5)
Hydraulic System	type l (gal)	Premium grade, anti-wear hydraulic fluid SAE 10W30 40 (8)
Articulated Joint	type qty.	Mobil XHP222 Grease as required
Steering Cylinder	type qty.	Mobil XHP222 Grease as required
Radiator	type qty. %	Water / Glycol 50 / 50
Exciter / Drive Bearings	type	Mobil XHP222 Grease
Drive Gear / Seals	type	Mobil XHP222 Grease

### 8.4 Sound and Vibration Specifications

Products are tested for sound pressure level in accordance with EN ISO 11204. Sound power level is tested in accordance with European Directive 2000/14/EC - Noise Emission in the Environment by Equipment for use outdoors.

The sound pressure level at operator's location ( $L_{pA}$ ) = 83 dB(A).

The guaranteed sound power level ( $L_{WA}$ ) = 109 dB(A).

Because this machine is operated using remote control the operator is not exposed to vibration.

### 8.5 Dimensions

mm(in.)

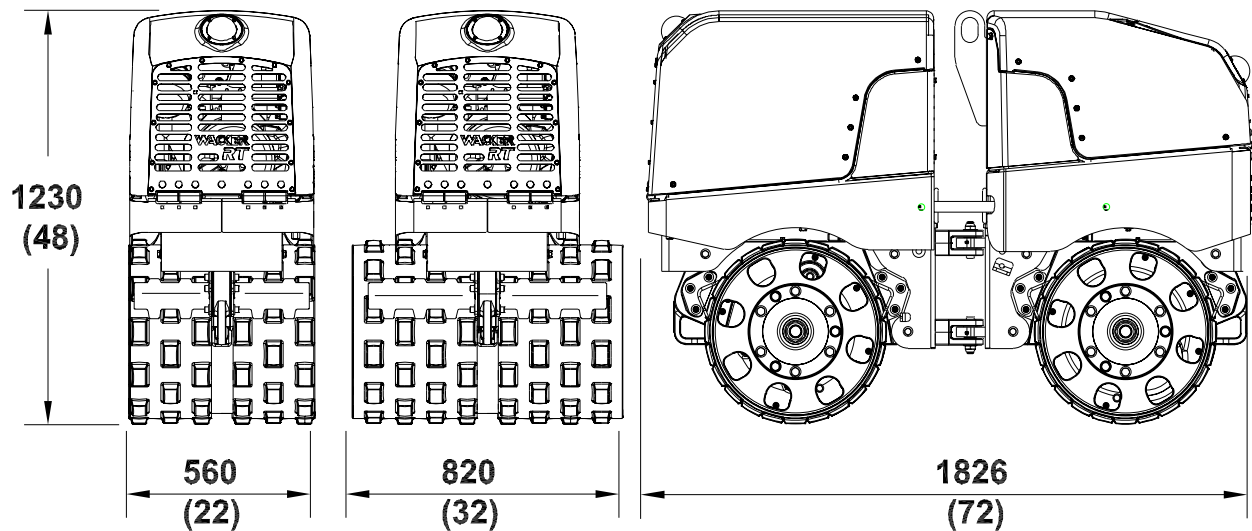

wc\_gr000232

### 8.6 Radiation Compliance

This machine meets the radio interference radiated emission requirements of European Standard EN 13309 for Construction Machinery.



ROLLER COMPACTOR

www.aem.org



# SAFETY MANUAL

## FOR OPERATING AND MAINTENANCE PERSONNEL

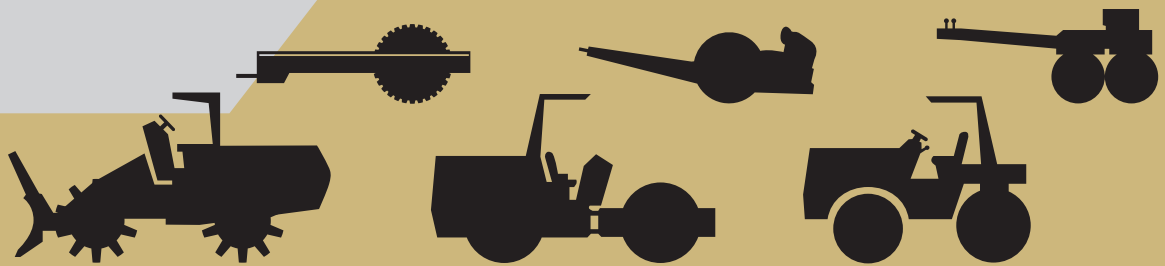

## SAFETY ALERT SYMBOL



This Safety Alert Symbol means **ATTENTION** is involved!

The Safety Alert Symbol identifies important safety messages on machines, safety signs, in manuals, or elsewhere. When you see this symbol, be alert to the possibility of personal injury or death. Follow the instructions in the safety message.

*Why is SAFETY important to YOU?*

### 3 BIG REASONS:

- Accidents **KILL** or **DISABLE**
- Accidents **COST**
- Accidents **CAN BE AVOIDED**

## NOTICE OF COPYRIGHT PROTECTION

AEM Safety Manuals are protected as a copyrighted work with ownership duly registered with the Copyright Office, Washington, D.C. Any reproduction, translation, decompiling or other use of an AEM Safety Manual, or portion thereof, or the creation of deriv-

ative works based on an AEM Safety Manual, without the prior written approval of AEM, is expressly prohibited. Copyright infringement can result in civil and criminal sanctions, damages and other penalties being imposed.

<b>WORD OF EXPLANATION.....</b>	<b>2</b>
<b>FOREWORD.....</b>	<b>4</b>
<b>A WORD TO THE USER .....</b>	<b>5</b>
<b>FOLLOW A SAFETY PROGRAM .....</b>	<b>6</b>
<b>PREPARE FOR SAFE OPERATION.....</b>	<b>9</b>
<b>START SAFELY.....</b>	<b>15</b>
<b>WORK SAFELY .....</b>	<b>18</b>
<b>PARK &amp; SHUTDOWN SAFELY .....</b>	<b>23</b>
<b>LOAD &amp; UNLOAD MACHINE SAFELY .....</b>	<b>25</b>
<b>TRANSPORTING SAFELY .....</b>	<b>26</b>
<b>PERFORM MAINTENANCE SAFELY .....</b>	<b>28</b>
<b>SPECIAL OPERATING AND MAINTENANCE PRECAUTIONS.....</b>	<b>43</b>
<b>TEST YOUR KNOWLEDGE .....</b>	<b>47</b>
<b>A FINAL WORD TO THE USER .....</b>	<b>48</b>

|

## **WORD OF EXPLANATION**

The following is a partial list of reference material on safe operating practices:

U.S. Department of Labor publishes safety and health regulations and standards under the authority of the Occupational Safety and Health Act for the general construction and mining industries. Its address is: U.S. Department of Labor, 200 Constitution Avenue, NW, Washington, DC 20210.

SAE - Society of Automotive Engineers, Inc., 400 Commonwealth Drive, Warrendale, PA 15096, publishes a list, "Operator Precautions," SAE J153 MAY, 1987.

Association of Equipment Manufacturers, 111 East Wisconsin Avenue, Milwaukee, WI USA 53202, publishes the Roller Compactor Safety Manual and other safety-related material.

This Safety Manual covers many different types of roller compactors ... including steel wheel rollers, vibratory rollers, rubber-tired rollers, segmented pad/sheepsfoot soil compactors and landfill compactors. These may be either self-propelled ride-on, walk-behind or towed rollers. They may be used for the compaction of asphalt, soil, landfill or other materials. Excluded from coverage are vibratory plates and hand rammers.

Regardless of which machine you operate, it is YOUR responsibility to study and understand this Safety Manual, and to see that a copy remains with your machine. The manual begins with your "safety homework," takes you step-by-step through your working day, and ends with maintenance operations.

Manufacturers produce machines with many built-in safety features. Employers provide accident prevention programs. Yet, the ultimate responsibility to operate and maintain your machine with the skill, care and knowledge essential for safety is YOURS.

Do not operate your machine until you have been trained in the use of all operating controls and understand the handling characteristics of the machine.

**REMEMBER — SAFETY ... YOURS AND THAT OF THOSE AROUND YOU ... IS UP TO YOU!**

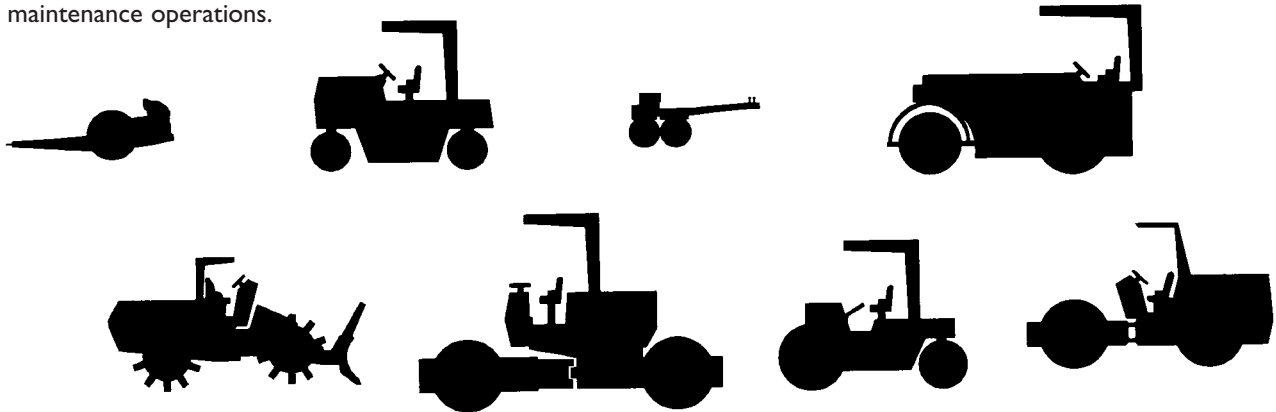

## FOREWORD

This safety manual is intended to point out some of the basic situations which may be encountered during the normal operation and maintenance of your machine, and to suggest possible ways of dealing with these conditions.

Additional precautions may be necessary, depending on application, machine type, configuration and attachments used, and conditions at the work-site or in the maintenance area. The manufacturer has no direct control over machine application, operation, inspection, lubrication or maintenance. Therefore, it is your responsibility to use good safe practices in these areas.

The information provided in this manual supplements the specific information about your machine that is contained in the manufacturer's manual(s). Other information which may affect the safe operation of your machine may be contained on safety signs, or in insurance requirements, employer's safety programs, safety codes, local, state/provincial and federal laws, rules and regulations.

If you do not understand any of this information, or if errors or contradictions seem to exist, consult with your supervisor before operating your machine.

**IMPORTANT: If you do not have the manufacturer's manual(s) for your particular machine, get a replacement manual from your employer, equipment dealer, or manufacturer of your machine. Keep this safety manual and the manufacturer's manual(s) with your machine.**

Unauthorized modifications of machines create hazards. Machines should not be modified or altered unless prior approval is obtained from the manufacturer.

It is your responsibility to read and understand this safety manual and the manufacturer's manual(s) before operating your machine. This safety manual takes you step-by-step through your working day.

Remember that **YOU are the key to safety**. Good safety practices not only protect you but also protect the people around you. Study this manual and the manufacturer's manual(s) for your specific machine. Make them a working part of your safety program. Keep in mind that this safety manual is written for only this type of machine. Practice all other usual and customary safe working precautions, and above all — (FIG. 1)

**REMEMBER — SAFETY IS UP TO YOU**  
**YOU CAN PREVENT**  
**SERIOUS INJURY OR DEATH**



FIG. 1

## FOLLOW A SAFETY PROGRAM

### KNOW THE RULES

Every employer is concerned about safety. Safe operation and proper maintenance of your machine can prevent accidents. **KNOW** the rules — **LIVE** by them. (FIG. 2)

When starting work at a new site, check with the designated safety coordinator for specific safety instructions. **DON'T LEARN SAFETY THE HARD WAY.**

Know the meaning of all hand signals, signal flags, signs and markings.

Know the traffic rules used at the work site. Know who the signal person is; watch and obey their signals.

Know where the fire extinguishers and first aid kits are kept and how to use them. Know where to get proper aid and assistance when needed.

Use common sense to avoid accidents. If an accident does occur, be prepared to react to it quickly and effectively. **NEVER PANIC.**

Know how to use the emergency communications system to summon help when necessary.



FIG. 2

## KNOW WHAT IT IS?

Consult your supervisor for specific instructions on a job, and the personal safety equipment required. For instance, you may need:

- Hard Hat
- Safety Shoes
- Eye Protection
- Face Protection
- Heavy Gloves
- Reflector Vests
- Hearing Protection
- Respirators

Do not wear loose clothing or any accessory — flopping cuffs, untied shoelaces, dangling neckties and scarves, rings, wrist watches, or other jewelry — that can catch on protruding or moving parts or controls. Long hair should be securely bound to prevent entanglement with moving parts. (FIG. 3)

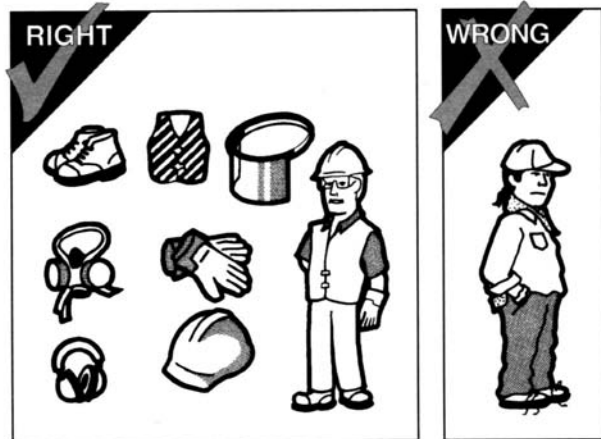

FIG. 3

# FOLLOW A SAFETY PROGRAM

## BE ALERT!

Know where to get assistance. Know how to use a first aid kit and fire extinguisher or fire suppression system. (FIG. 4)

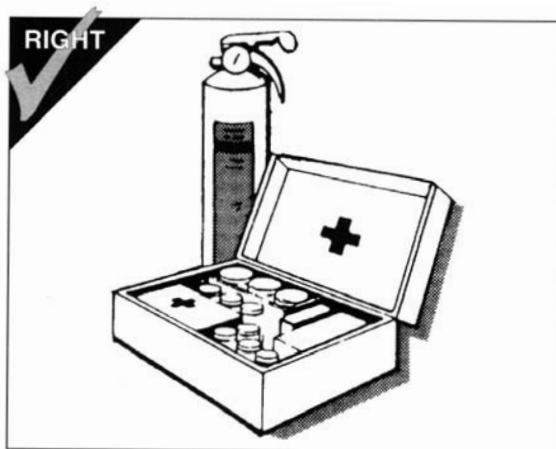

FIG. 4

## BE AWARE!

Take advantage of training programs offered.

Safety programs require that one person at each jobsite be assigned the overall responsibility and authority for safety. Know who that person is, and COMMUNICATE.

Know what the jobsite rules are, and FOLLOW THE RULES. Be safety conscious, responsible and reliable. Think about safety BEFORE something happens.

Report unsafe conditions to a supervisor immediately!

## BE CAREFUL!

Human error is caused by many factors: carelessness, fatigue, overload, preoccupation, incompatibility between operator and the machine, drugs, and alcohol to name a few. Eliminate these factors BEFORE accidents occur. Damage to the machine can be fixed in a short period of time, but injury, or death has a lasting effect.

**FOR YOUR SAFETY AND SAFETY OF OTHERS, ENCOURAGE YOUR FELLOW WORKERS TO ACT SAFELY.**

# PREPARE FOR SAFE OPERATION

## LEARN TO BE SAFE

READ the operator's manual. If one has not been provided, GET ONE AND STUDY IT BEFORE OPERATING THE MACHINE. If you have any questions contact the manufacturer.

Know the positions and understand the functions of all controls before attempting to operate a machine. Know the meaning of all identification symbols on your controls and gauges. (FIG. 5)

Know the location of the emergency shut-down control if the machine is so equipped.

Know the capabilities and limitations of the machine ... such as speed, breaking and steering.

Know the operational and transport dimensions of your machine to avoid inadvertently hitting something during operation or transporting.

Carefully read and follow the instructions on all safety signs on the machine. Keep safety signs in good condition. Replace missing or damaged safety signs.



FIG. 5

NEVER operate a machine which is new to you without first being instructed in its proper operation.

## CHECK IT OUT!

Always conduct a pre-shift inspection before operating any machine. Know what safety devices your machine is equipped with ... and see that each item is securely in place and in operating condition. (FIG. 6)

For example:

- Safety Blocks and Locks
- Other Locking Devices
- Lights
- Alarms
- Horn
- Guards and Shields
- Shut-Down Devices
- First Aid Kit
- Fire Extinguishers



FIG. 6

# PREPARE FOR SAFE OPERATION

## TIRES

Inspect pneumatic tires (if so equipped) for damage, wear, and proper inflation. Never operate with over-inflated or under-inflated tires. (FIG. 7)

Check that all wheel lug nuts are present and tight.

NEVER START OR OPERATE A MACHINE KNOWN OR SUSPECTED TO BE DEFECTIVE OR MALFUNCTIONING.

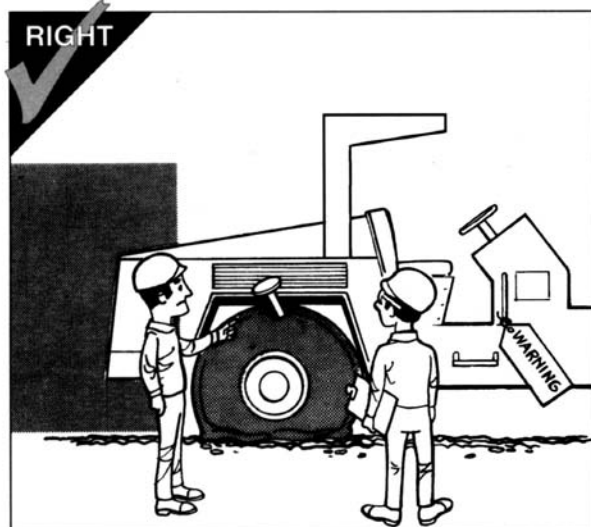

FIG. 7

## KNOW YOUR MACHINE

Never operate a machine for which you are not trained or qualified.

Familiarize yourself with pedals, controls and instruments – their locations and function.

To handle controls without slipping, wipe them clean of oil and grease.

Remove tools, supplies and other materials from the working areas and machine walkways – and keep these areas free of trash.

Make sure the items you do carry are not loose or in the way.

## ARE REPAIRS MADE?

If your daily check uncovers any item that needs attention – repair, replacement, or adjustment – report it to your supervisor and tag the machine on the start switch and/or other appropriate, prominent location. A minor malfunction could be a sign of a more serious problem if the machine is operated.

# PREPARE FOR SAFE OPERATION

## FIRE PREVENTION

Never allow flammable fluids or materials to contact hot surfaces.

Never refuel:

- When engine is running
- While smoking
- Near open flames or sparks
- In poorly ventilated area

Never overfill fuel tank or fluid reservoirs. Clean up spills immediately.

Replace fuel cap securely after filling.

Check for fuel, oil and hydraulic fluid leaks. Replace worn or damaged hoses/tubes. After repairs are made, clean the machine before you operate it.

Inspect electrical wiring for worn or damaged insulation. Install new wiring if wires are damaged.

Because ether or other starting fluids are flammable, do not smoke when using them. Always follow the instructions on the container and in the operator's manual for your machine. (See page 19.)

Batteries produce explosive gases. Keep open flame or sparks away. See the manufacturer's instructions when servicing the batteries, when using jumper cables or when using a battery charger. (See pages 36 and 37.)

Remove all trash or debris from the machine. Make sure that oily rags or other flammable material are not stored on the machine. (FIG. 8)



FIG. 8

11

# PREPARE FOR SAFE OPERATION

## PREPARING TO ROAD THE MACHINE

Know what conditions you will likely encounter:

- Insufficient clearances
- Traffic congestion
- Type of surface
- Steep grades
- Restricted visibility

Determine appropriate warnings to be used. (FIG. 9)  
Know whether you will need to be escorted.

If the machine is to travel on a road or highway, refer to the manufacturer's manual(s) for instructions. Become familiar with local laws and ordinances affecting driving on highways. Use "slow moving vehicle" emblem. Make sure flags, lights, and warning signs are in place.

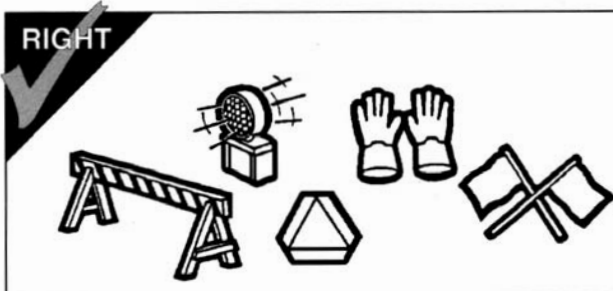

FIG. 9

Select the proper gear before negotiating steep grades. (FIG. 10)

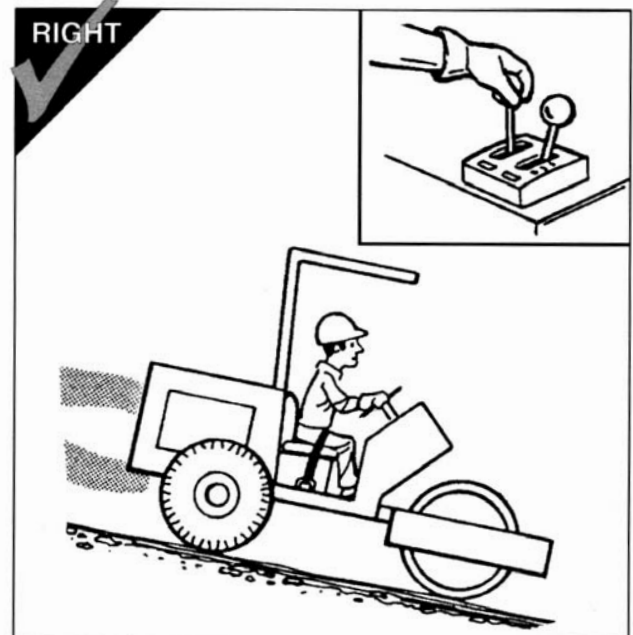

FIG. 10

## PREPARE FOR SAFE OPERATION

Before starting, carefully inspect your machine for any evidence of physical damage such as cracking, bending or deformation of plates or welds. Check for cracking or flaking of paint, which may indicate an excessive strain or dangerous crack in the material below. Check for loose, broken or missing parts such as Roll-Over Protective Structure (ROPS) support brackets, vibration isolators, and nuts and bolts. If potentially serious problems are found, do not operate the machine until appropriate repairs are completed.

Check the level of all fluids ... brake, transmission, power steering, engine coolant, hydraulic system, and others. Fill low reservoirs only to the proper level.

Check the various systems (hydraulic, cooling, etc.) for leaks. (FIG. 11) Inspect all plugs, filler caps and fittings for tell-tale signs of leaks. ALWAYS use a flashlight or shielded trouble light when checking ... Never an open flame. Repair any leaks, or have them repaired by authorized service personnel. (See pages 28 through 42 for additional service cautions.)

Check the fuel level and, if low, fill the tank with the proper grade of clean fuel before extended operation (following the instructions on page 34).

A stalled or faltering engine can result in a real hazard when operating on grades, in traffic or in heavily congested areas.

NEVER smoke when checking fuel level or refueling.

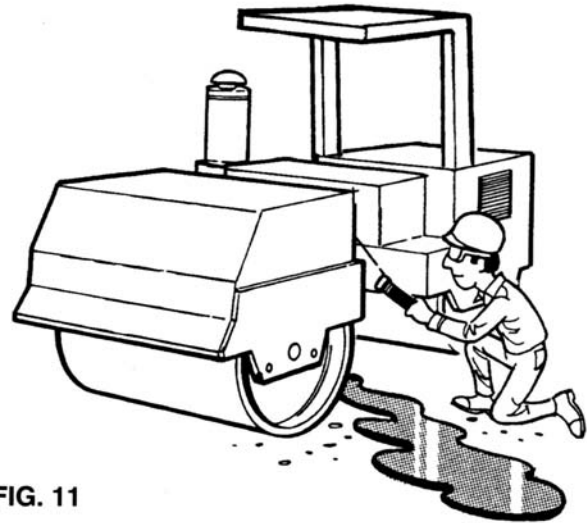

FIG. 11

13

## PREPARE FOR SAFE OPERATION

### BE SURE THE WORK AREA IS SAFE

Before beginning operation, thoroughly check the area for any unusual conditions that could be dangerous. (FIG. 12) Check for hidden holes, drop-offs or overhead obstacles that could be dangerous. Check the clearance under overhead power and phone lines. LOOK UP AS WELL AS DOWN.



FIG. 12

Be observant of other workmen, bystanders and other machines in the area. Be especially careful if trenches, lightpoles, tiles, buildings, etc. are within the effective range of a vibratory compactor. IMPROPER OPERATION COULD RESULT IN DAMAGE OR INJURY.

Remember, the danger of sliding and/or tipping on steep slopes is always present ... regardless of how heavy or "stable" your machine may appear to be. When operating under these conditions, the use of ROPS and seat belts reduces the hazard to operating personnel.



Walk around your machine once more just prior to mounting it – checking for people and objects that might be in the way – then MOUNT PROPERLY USING STEPS AND HANDHOLDS PROVIDED.

Always use seat belts if your machine is equipped with a ROPS.

Just before starting, check all controls ... such as forward and reverse, steering, transmission and throttle to be sure they are in the correct start-up position. (FIG. 13) The parking brake should be applied during the start-up operation.

Check for proper functioning of all operating and shut-down controls.

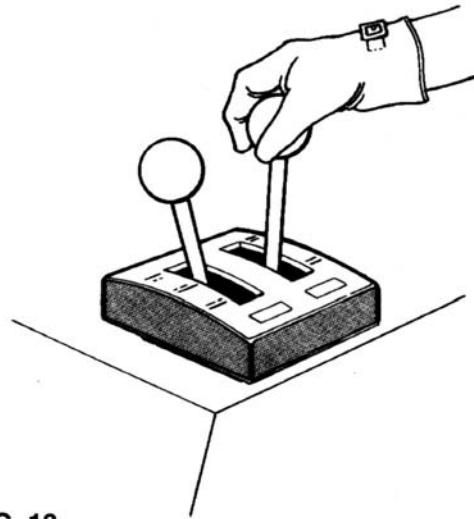

FIG. 13

## START CORRECTLY

Know the PROPER starting procedure for your machine. Follow the manufacturer's operation manual ... to the letter.

Then, start your engine.

# START SAFELY

## IMMEDIATELY AFTER STARTING THE ENGINE ...

- Observe gauges, instruments, and warning lights to ensure that they are functioning and their readings are within the normal operating range. (FIG. 14)
- Be sure work area is safe for test operation of the various controls and attachments.
- Operate all controls: make certain they operate properly, and "feel" right. Accustom yourself to the "feel" of your machine.
- Listen for any unusual noises; smell for any unusual odors; look for any signs of trouble.
- Check all warning and safety devices and indicators.
- If safety-related defects or malfunctions are detected, shut down the machine. Correct it, or notify your supervisor. **DO NOT OPERATE UNTIL CORRECTED.**

Check operation of service and parking brakes on level ground if possible.

Check service brakes (including hydrostatic brakes, if so equipped) in both forward and reverse operation (FIG. 15) ACCORDING TO THE MANUFACTURERS INSTRUCTIONS.

If an unsafe condition cannot be remedied immediately, notify your supervisor and tag the machine on the start switch and/or other appropriate, prominent location. (See page 28 for Lockout/Tagout procedure.) No machine should be operated if any part is not in safe operating condition. Make certain that any unsafe condition has been satisfactorily remedied.

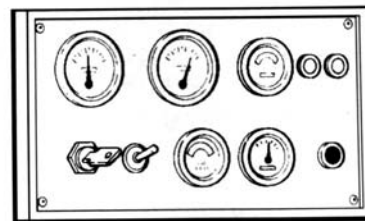

FIG. 14



FIG. 15

## COLD WEATHER OPERATION

Consult the engine manufacturer's operation manual for proper cold weather starting procedure.

When using cold weather starting aids, be sure to follow the engine manufacturer's instructions. (FIG. 16)

After starting, operate all systems slowly and gently until properly warmed up.



FIG. 16

## BOOSTER CABLE INSTRUCTIONS

1. Connect positive (+) cable to positive post of discharged battery.
2. Connect other end of same cable to same marked post of booster battery.
3. Connect negative (-) cable to other post of booster battery.
4. Make final connection on stalled vehicle away from battery, either on vehicle frame or engine block.
5. Start vehicle and remove cables in reverse order of connection.

17

## WORK SAFELY

### REMEMBER THESE RULES

When roading or operating a machine, always stay in the operator's station. NEVER mount or dismount a machine that is moving. Maintain control of your machine at all times.

ALWAYS operate your machine slowly until fully familiarized with its operation.

Constantly check your total work area for potential hazards.

Never JUMP on or off your machine. Use the steps and handholds provided to mount or dismount safely. Maintain three point contact when mounting or dismounting. (FIG. 17)

- Never use controls or levers as hand holds.
- Never jump off the machine.

Look, listen and smell for possible malfunctions. If malfunctioning controls or erratic operation are detected, correct or report them immediately. **DO NOT OPERATE THE MACHINE UNTIL CORRECTED.**

Prevent asphyxiation. If you must operate in a building or other enclosed area, or if your machine is equipped with an enclosed cab, be certain there is adequate ventilation.

Use extra care when refueling. (See page 34 for special precautions.)



FIG. 17

**! DANGER!  
PINCH AREA**

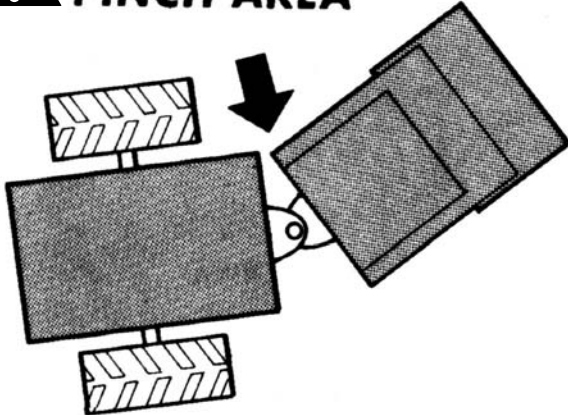

**FIG. 18**

For maximum safety on machines with more than one operator's position, operate from the position giving the greatest visibility of potential hazards.

NEVER allow unqualified or unauthorized personnel to operate your machine.

NEVER allow other personnel to ride on your machine unless appropriate seating is provided ... and then only if authorized to do so.

NEVER abuse your machine. Misuse or abuse can cause an accident.

NEVER enter or place any part of your body in the "hinge area" or other "pinch" areas of an articulated machine while the engine is running, or when there is any chance another person might start the machine. (FIG. 18)

Give the right-of-way to loaded equipment on haul roads. Maintain a safe distance from personnel, motor vehicles and other machines.

Your safety, and the safety of those around you, is determined by the care and judgment YOU use while operating your machine.

## WORK SAFELY

### WORKING ON SLOPES

When working on slopes, avoid sidehill travel whenever possible ... rather operate up and down the slope. (FIG. 19 & 20) Remember the danger of sliding and/or tipping on steep slopes is always present ... regardless of how heavy or "stable" your machine may appear to be.

ALWAYS use seat belts IF your machine is equipped with a ROPS.

NEVER allow the engine or machine to overspeed.

When climbing or descending steep grades, ALWAYS select the proper gear BEFORE starting on the slope, to assure adequate power or engine braking.

If your machine has a gear shift, select a low gear. If your machine has a hydrostatic drive, the speed control should be in the slow travel position, close to neutral ... NEVER in the fully displaced position.

On machines that have a gear shift AND a hydrostatic control, BOTH controls must be in their slow travel position.

ALWAYS be sure that manually operated gear type transmissions are fully engaged BEFORE starting onto a grade. DO NOT attempt to change the gear selection while traveling on a grade. See the manufacturer's manual for specific instructions.

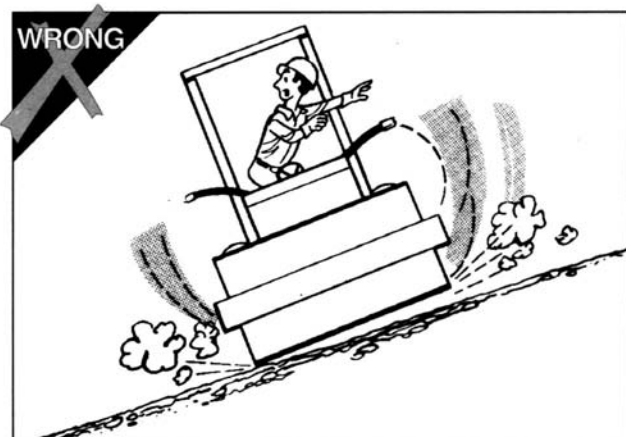

**FIG. 19**

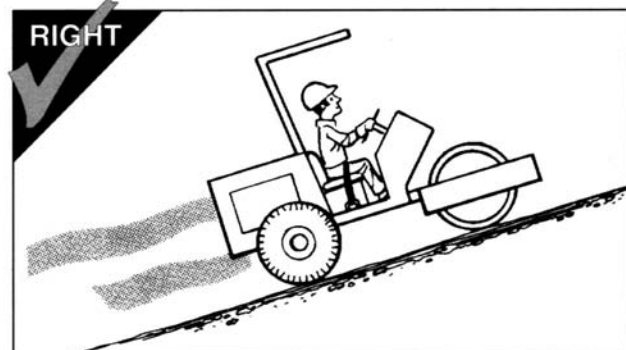

**FIG. 20**

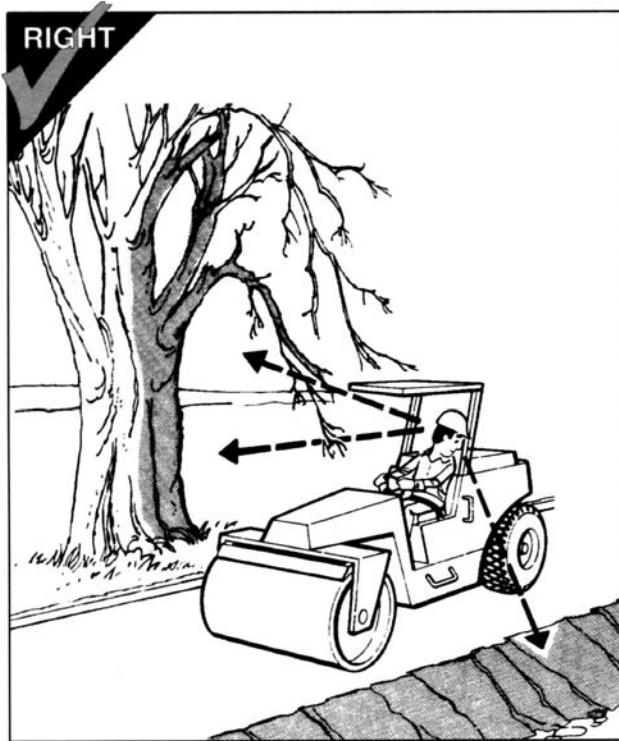

RIGHT

FIG. 21

Avoid operating your machine too close to an overhang, deep ditch or hole. If your machine inadvertently gets close to a tipping condition or drop-off, STOP and get off the machine after applying the parking brake ... plan your moves carefully before proceeding. Reversal is often the best move.

Be alert to potential caving edges, falling rocks and slides.

Check for overhead obstacles that could be dangerous. LOOK UP AS WELL AS DOWN. (FIG. 21)

Be alert to obstacles and excessively rough terrain. Back away from them and go around.

Always travel slowly over rough terrain and hillsides. Maintain a speed consistent with the working conditions.

## WORK SAFELY

When traveling on a public road, obey all traffic regulations and be sure that the proper clearance flags, lights and warning signs ... such as the "slow moving vehicle" emblem ... are used. (FIG. 22)

NEVER speed ... and NEVER coast in neutral.

When roading the machine know your approximate stopping distance at any given speed.

NEVER turn corners at excessively high speeds. (FIG. 23)

Always look in all directions before reversing your direction of travel.

Use EXTRA caution when working in close quarters or when traveling through congested areas. Courtesy pays off.

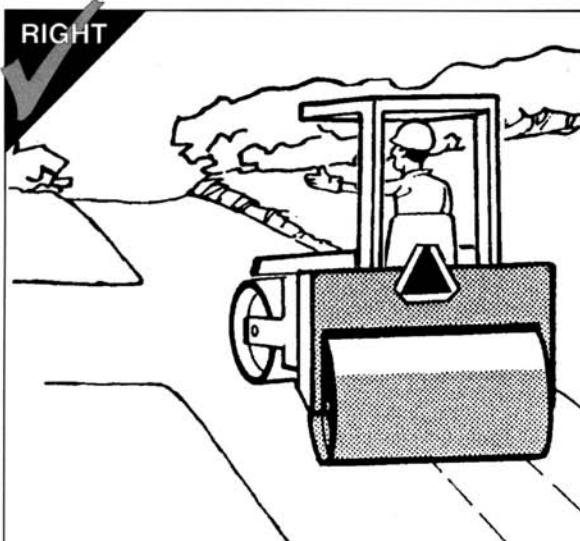

RIGHT

FIG. 22

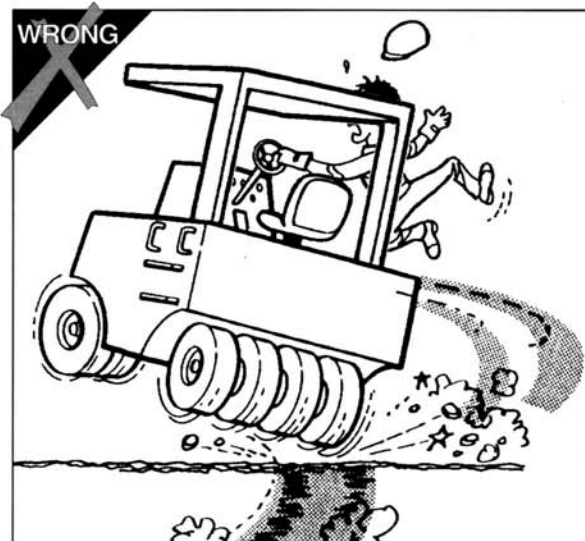

WRONG

FIG. 23

# PARK AND SHUT DOWN SAFELY

## PARK SAFELY

Park in an off the road area, out of traffic, or as instructed. If necessary to park in a traffic lane, use the appropriate flags, barriers, flares, lights and warning signals. Provide advance warning signals in the traffic lane to warn approaching traffic.

Park on level ground whenever possible. (FIG. 25) When not possible, position the machine at right

angles to the slope. Make sure the machine is on a firm footing, and that there is no danger of sliding. Do NOT leave your machine until you are sure it is safely blocked in both directions and parking brakes firmly applied. (FIG. 24)

Lower the blade and all other hydraulically operated attachments (if so equipped ) to the ground.

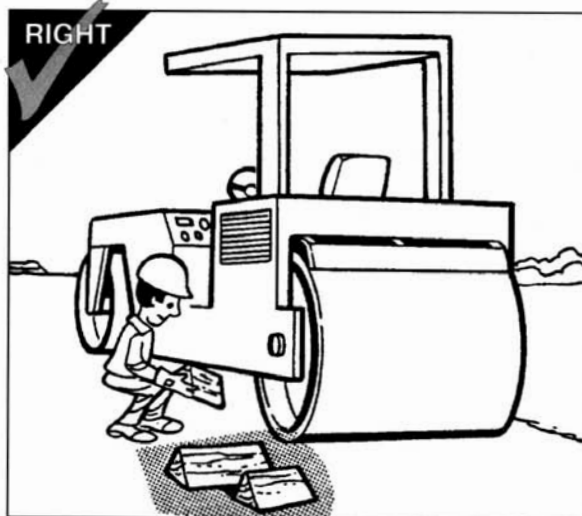

FIG. 24

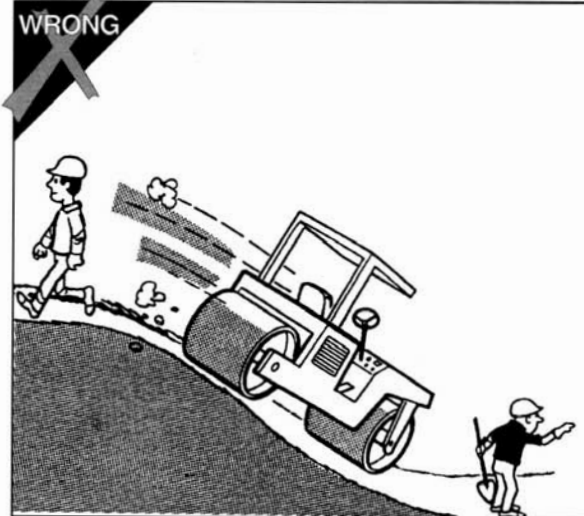

FIG. 25

23

# PARK AND SHUT DOWN SAFELY

## SHUT DOWN PROPERLY

Know the proper shut-down procedure for your machine. As with the starting procedure, this varies with the type and model of machine.

Follow the manufacturer's operation manual for YOUR machine. Remove the key(s) to prevent unauthorized starting and movement, and position and lock any antivandalism devices.

## DISMOUNT PROPERLY

NEVER dismount from your machine until it is fully stopped and the engine is shut off.

NEVER jump off your machine. (FIG. 26) After stopping, use the steps and handholds provided to dismount safely. Maintain three point contact when dismounting.



FIG. 26

Loading and unloading machines always involves potential hazards. **EXTREME CAUTION SHOULD BE USED.**

Know the correct loading and unloading procedures for your machine.

All machines are not loaded and unloaded the same way. The procedures recommended by the manufacturer should always be followed.

Several precautions are applicable to all machines:

- NEVER load or unload machine by yourself.
- Keep all non-essential personnel clear of loading and unloading area.
- Load and unload on a level surface.
- ALWAYS use ramps of adequate size and strength. Be sure ramps are sufficiently wide, and long enough to provide a safe loading slope.
- NEVER use ramps that are cracked, damaged, or of questionable strength. (FIG. 27)
- Be sure that the ramps are securely positioned and fastened, and that the two sides are at the same level as one another.

- The ramp surface must provide adequate traction. Be sure the surface is clean and free of grease, oil, ice, and loose material.
- The hauling vehicle should be blocked to prevent movement during loading or unloading of the machine.
- For proper tie-down instructions, see the manufacturer's manual.

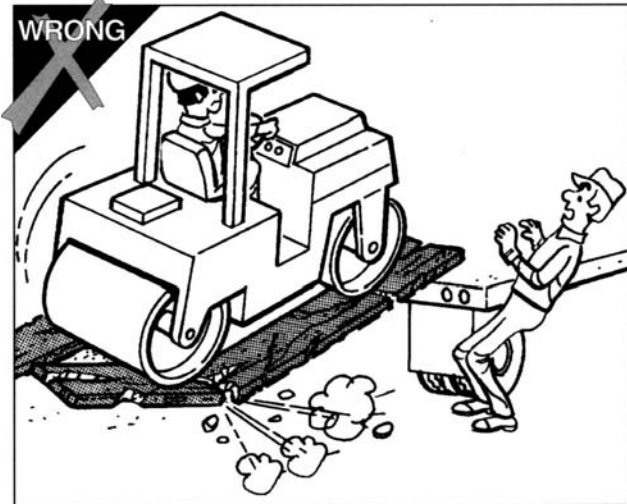

FIG. 27

## TRANSPORTING SAFELY

### GENERAL

When towing a machine on a trailer, or a machine equipped with “portability or transport wheels”, ALWAYS use a hauling vehicle of sufficient weight, horsepower and braking capacity to maintain proper control.

NEVER attempt to tow a trailer or machine if the hitching devices are of insufficient or questionable capacity, improperly matched in size or shape, or positioned at improper heights.

When towing a machine equipped with portability or transport wheels, ALWAYS follow the manufacturer's towing instructions.

### BEFORE TOWING

When connecting a trailer to a hauling vehicle, block under the trailer's tongue before attempting to make the connection. NEVER attempt to lift heavy tongues or move heavy trailers by hand. NEVER get any part of your body under the tongue when hitching or unhitching.

ALWAYS make sure the hitch is properly and securely locked.

ALWAYS use safety chains between the hauling vehicle and trailer or towed machine. Be sure the chains are properly and securely connected ... at BOTH ends. Cross the chains under the tongue when connecting to the hauling vehicle.

ALWAYS make sure electrical and other connections between the hauling vehicle and trailer or towed machine are properly and securely made. After connecting, check the lights for proper operation. If the towed trailer or machine is equipped with brakes operable from the hauling vehicle, check to make sure they are operating properly.

ALWAYS be sure the portability or transport wheels, on machines so equipped, are LOCKED in the lowered position.

Check ALL tires for proper pressure, excessive or abnormal wear, and potentially dangerous cuts, bruises or bulges. Have any problems corrected before proceeding.

## TOWING

ALWAYS use EXTRA care when towing a trailer or machine... when maneuvering in tight places, when backing (visibility is reduced, and jackknifing must be avoided), and when towing on steep grades.

Know and obey all local, state and federal laws and regulations.

NEVER travel at speeds above those recommended by the manufacturer.

NEVER allow anyone to ride on a trailer or towed machine. (FIG. 28)

When necessary to disconnect and park a trailer or towed machine, ALWAYS select a location that is level and, if possible, one where children are unlikely to be present. BEFORE disconnecting a trailer, chock the front AND rear of the wheels, and block under the tongue.

See pages 23 through 24 for parking, shut-down procedures and roading machine for transport.

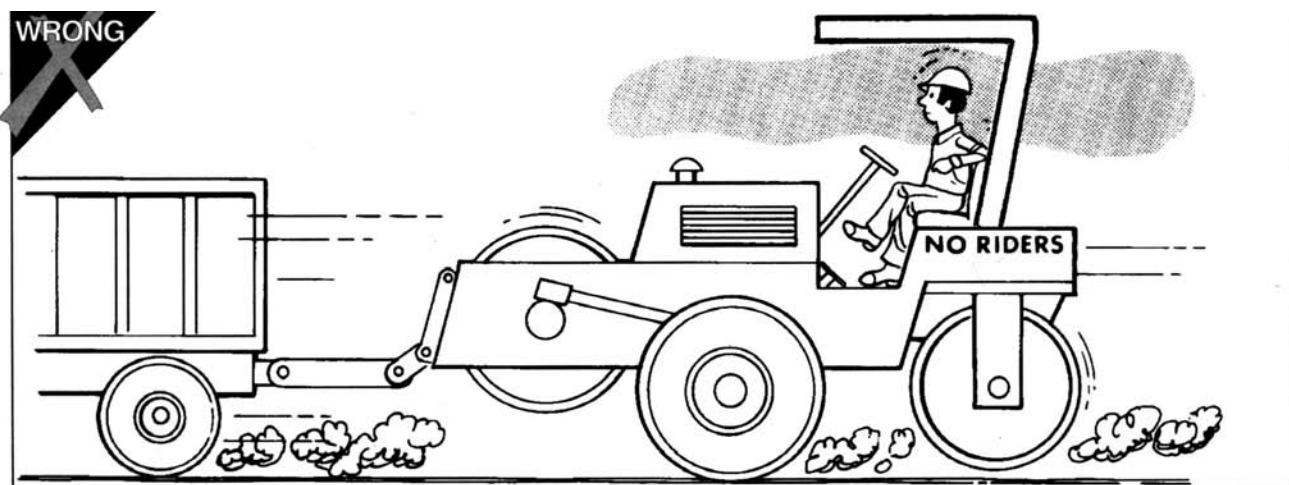

FIG. 28

27

## PERFORM MAINTENANCE SAFELY

### GENERAL

Maintenance work can be **hazardous** if not done in a careful manner. All personnel should realize the hazards and strictly follow safe practices.

NEVER perform any work on the equipment unless authorized to do so. (FIG. 29) Before performing any maintenance or repair work, consult the Instruction Manual. Follow the manufacturer's recommended procedures.

BEFORE any maintenance work is begun, review LOCKOUT/TAGOUT procedures. LOCKOUT controls and/or energy source and place a warning label to alert workers of shutdown.

PRIOR to removal of LOCKOUT/TAGOUT, the equipment must be fully operational and all personnel accounted for. Except in cases of emergency, the removal of the LOCKOUT/TAGOUT should be done by the initiating person prior to the return to start-up.

BEFORE doing any major work, or work on the electrical system, disconnect the batteries.

REPLACE all missing or broken guards and panels.

USE proper nonflammable cleaning solvents. Follow solvent manufacturer's instructions.

ALWAYS remove all flammable materials in the vicinity of welding and/or burning operations.

BURNING OR WELDING in the vicinity of acoustical material may release hazardous fumes.



FIG. 29

## CLOTHING AND PERSONAL PROTECTIVE ITEMS

Keep hands and clothing well away from engine fan and moving parts while engine is running.

ALWAYS wear appropriate safety glasses, goggles or face shield when working. (FIG. 30) Proper eye protection can keep flying particles from grinding, drilling or hammering operations, or fluids such as fuel, solvents, lubricants and brake fluids, from damaging your eyes. Normal glasses do NOT provide adequate protection.

ALWAYS wear a hard hat and safety shoes. (FIG. 30) ALWAYS wear hearing protectors when exposed to high noise levels for extended periods. ALWAYS wear a respirator when painting or exposed to dusty conditions. ALWAYS keep your pockets free of loose objects which can fall out and drop into



FIG. 30

FIG. 31

machinery. (FIG. 31) Heavy gloves should be worn for many operations.

## EXHAUST FUMES

Engine exhaust fumes can cause sickness or death. If it is necessary to run an engine in an enclosed area, use an exhaust pipe extension. If you do not have an exhaust pipe extension, be positive the area is adequately ventilated. (FIG. 32)



FIG. 32

## HEAVY PARTS

Handle tools and heavy parts sensibly – with regard for yourself and other persons. Lower items – don't throw or drop them.

ALWAYS use proper hoisting equipment for lifting heavy loads.

# PERFORM MAINTENANCE SAFELY

- Keep machine in proper adjustment at all times. Serious injury could result if adjustments are neglected.
- Whenever possible, AVOID working on a machine with the engine running. If the engine must be run to make checks or adjustments, put the transmission in neutral, set the parking brake and chock the drum and wheels securely ... front and rear ... to prevent movement in either direction.
- Personnel can be caught by moving parts when the **guards are removed** for access in making repairs. A repair or maintenance job is not complete until guards, plates and other safety devices have been replaced.
- NEVER put your fingers in open gears or reach through the spokes of a gear.
- Before working on the fuel system, close the fuel shut-off valve. NEVER smoke or use open flames near the machine while working on the fuel system.
- **Remove and store** all tools before resuming operation.

- Before working in the pivot or "pinch" area of an articulated machine, securely attach the steering frame lock to prevent the machine from turning. (FIG. 33) Enter this area only when necessary.
- Connect any other safety locks provided before proceeding with the work.

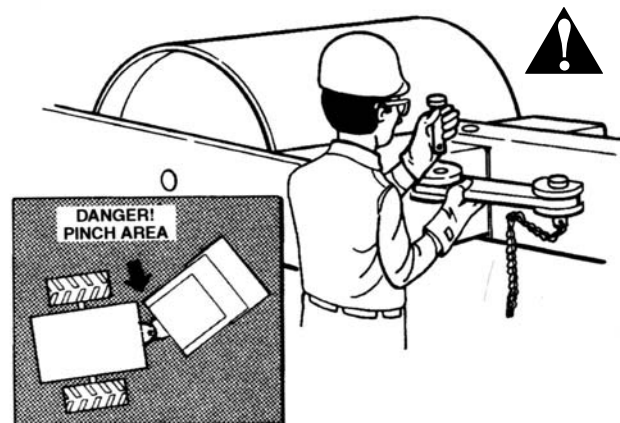

FIG. 33



Before beginning welding or burning operations, drain fuel lines and tank and move all flammable material to a safe distance, and be certain a fire extinguisher is readily available. When welding fuel tanks, either gasoline OR diesel, ALWAYS drain the tank, fill with water, and leave cap off during the welding operation.

**All guards, plates and other safety devices must be properly replaced before the machine is returned to service** or serious injury to you or other personnel may result.

AVOID burning or welding near acoustical material whenever possible, as **hazardous** fumes may be released. If unavoidable, make sure the area is adequately ventilated, and that a fire extinguisher is ready available.

ALWAYS use authorized replacement parts that meet the machine manufacturer's specifications.

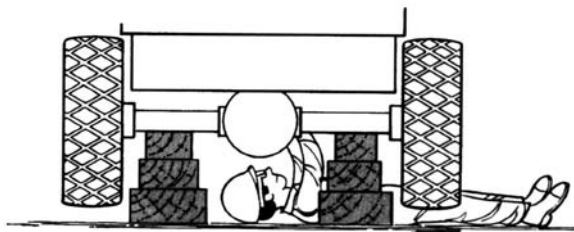

FIG. 34

## JACKING AND BLOCKING

ALWAYS lower all movable attachments to the ground or to their lowest position before servicing a machine.

If a machine must be raised for servicing or repairs, ALWAYS block the machine securely. Use axle stands or other rigid supports of ample capacity. NEVER rely solely on the jacks for support. If necessary to work under a machine, be absolutely certain it is adequately supported. (FIG. 34)

**WARNING:** Never use concrete blocks for supports. They can collapse under even light loads.

When jacking up a machine, use a SUITABLE jack, placed in the proper position, on a solid foundation.

Before working on a machine, chock the drum and wheels securely ... front and rear ... in such a manner as to prevent movement in EITHER direction. Securely attach the steering frame lock to prevent the machine from turning.

# PERFORM MAINTENANCE SAFELY

## FIRE PREVENTION

Whenever possible use a nonflammable solvent to clean parts. Do not use gasoline or other fluids that give off harmful vapors.

If flammable fluids, such as diesel fuel, must be used, extinguish open flames or sparks and do not smoke.

Store dangerous fluids in a suitable place, in approved containers which are clearly marked. NEVER smoke in areas where flammable fluids are used or stored. (FIG. 35)

**Use proper** nonflammable cleaning solvents. Follow solvent manufacturer's instructions for use.

**Always remove** all flammable material in the vicinity of welding and/or burning operations.

ALWAYS keep the floor in the work area clean and dry. Oily, greasy floors can easily lead to falls. Wet spots, especially near electrical equipment, can be hazardous. (FIG. 35)

Know where fire extinguishers are kept – how they operate – and for what type of fire they are intended.

Check readiness of any fire detectors and fire suppression systems.



FIG. 35

## FIRE PREVENTION CHECKLIST (FIG. 36)

- Remove debris such as rags, coal dust, oil, leaves, pine needles.
- Check and repair fuel and hydraulic leaks.
- Check and repair damaged wiring.
- Prevent hose and electrical wire harness abrasion.
- Tighten loose clamps and fittings.
- Secure loose wiring.
- Make sure guards and protective covers are in place.
- Make sure fire extinguisher is available and operable.

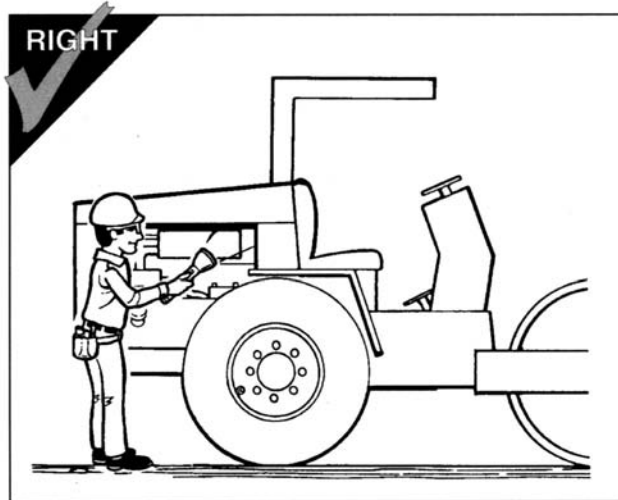

FIG. 36

# PERFORM MAINTENANCE SAFELY

## REFUELING (FIG. 37)

### Precautions

When refueling, the following precautions must be followed:

- Add proper type and grade of fuel only when machine is not running and machine is parked with no one in the cab.
- Fuel in a well-ventilated area.
- Turn off all electrical switches.
- Turn off cab heaters.
- Open lights, lighted smoking materials, flames, or spark producing devices shall be kept at a safe distance while refueling.
- Keep fuel nozzle in contact with tank being filled, or provide a ground to prevent static sparks from igniting fuel.
- Do not spill fuel on hot surfaces.
- Any spillage shall be cleaned immediately.

- Do not start engine until fuel cap is secured to the fuel tank and people are clear of the machine.
- ALWAYS make sure fuel, oil, hydraulic fluid and water are added to their proper tanks.

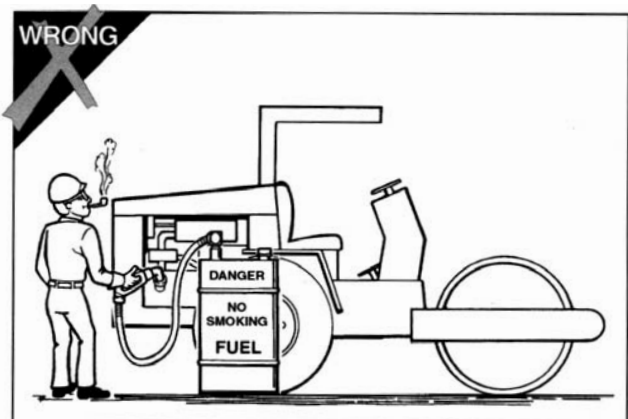

FIG. 37

## SERVICING COOLING SYSTEM

### When checking coolant level:

- Stop the engine and let the engine and radiator cool before checking. (FIG. 38)

### If an overheated engine requires a shutdown:

- **Wait for the radiator to cool.** The hot pressurized coolant can cause burn injuries. Never add coolant to an overheated system.
- **Overheating is a symptom of trouble.** Stop the engine and have the trouble corrected before serious damage occurs.
- If it is necessary to check an overheated engine use a heavy cloth, gloves, heavy clothing and safety glasses or goggles to protect yourself. Stand to the side, turn your face away, and slightly loosen the cap. Wait until the sound stops before removing the cap.

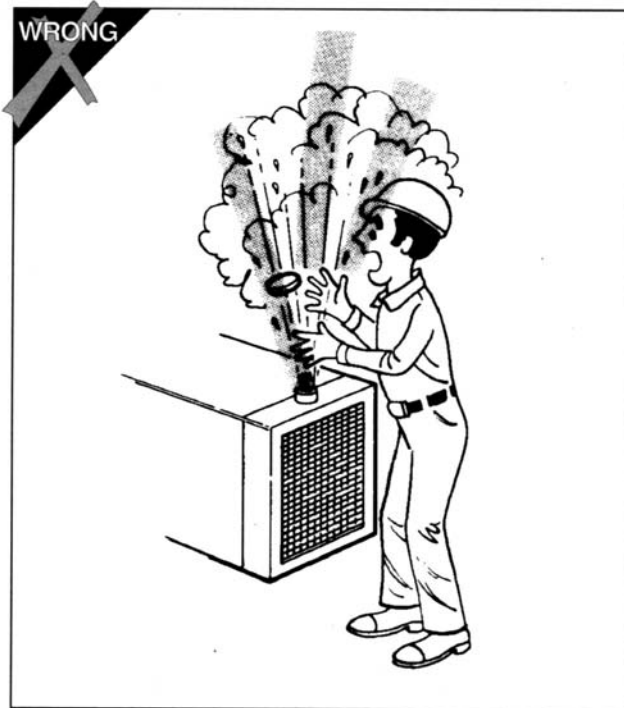

FIG. 38

35

# PERFORM MAINTENANCE SAFELY

## SERVICING BATTERIES

**Always wear** safety glasses and gloves when working with batteries.

**Before removing a battery,** turn off all electrical equipment, then disconnect the negative (-) battery cable first. Before installing a battery, turn off all electrical equipment, then connect the positive (+) battery cable first.

**To prevent sparking** at the posts when using a battery charger, always turn the charger off or disconnect it from its power source before connecting or disconnecting charger leads to battery posts. Caps on all cells should be left on and the vent caps would be covered with a wet cloth.

**Do not short** across the battery terminals. The spark **could** ignite the gases.

## BOOSTER CABLE INSTRUCTIONS (FIG. 39)

1. Connect positive (+) cable to positive post of discharged battery.
2. Connect other end of same cable to same marked post of booster battery.
3. Connect negative (-) cable to other post of booster battery.
4. Make final connection on stalled vehicle away from battery, either on vehicle frame or engine block.
5. Start vehicle and remove cables in reverse order of connection.

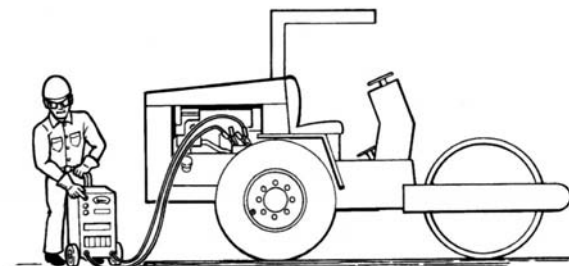

FIG. 39

## BATTERY SERVICING

To prevent a battery explosion: (Fig. 40)

- **Maintain** the electrolyte at the recommended level. Check level frequently. Add distilled water to batteries only before starting up, never when shutting down. With electrolyte at the proper level, less space is available for gases to accumulate in the battery.
- **Use a flashlight** to check the electrolyte level. Never use a flame. (Fig. 41)
- **Do not short** across the battery terminals. The spark could ignite the gases.

Battery acid will **burn skin**, eat holes in clothing, and may **cause blindness** if splashed into eyes. If you spill acid on yourself flush skin immediately with lots of water. Apply baking soda to help neutralize the acid. If acids gets in your eyes, flush immediately with large amounts of water and seek proper medical treatment immediately.

**When servicing batteries**, remember that a lead-acid storage battery generates (when charging or discharging) hydrogen and oxygen – a very explosive mixture. A spark of flame could ignite these gases.



FIG. 40



FIG. 41

37

# PERFORM MAINTENANCE SAFELY

## HYDRAULIC SYSTEMS

**NOTE:** Hydraulic Systems have “special features”. Some of the features affecting your safety are listed below.

**Pressure** can be maintained in hydraulic and air circuits long after the engine has been shut down. This pressure can cause hydraulic fluid or items such as pipe plugs to “shoot out” at high speed if pressure is not released correctly. **Release system pressure** before attempting to make adjustments or repairs.

Consult the manufacturer’s instructions for correct procedure.

Before disconnecting **hydraulic fluid** lines, be sure you:

- Shut off engine.
- Always release any air pressure (supercharge) on the hydraulic reservoir.
- Move pedals and control levers repeatedly through their operating ranges to relieve all pressures.

**Pressurized hydraulic fluid** can penetrate the skin and **cause serious injury**. Therefore, be sure all connections are tight and that lines, pipes, and hoses are in good condition before starting the engine.

Fluid escaping from a small hole can be almost invisible. Use a piece of cardboard or wood, instead of your hands, to search for suspected leaks. (FIG. 42)

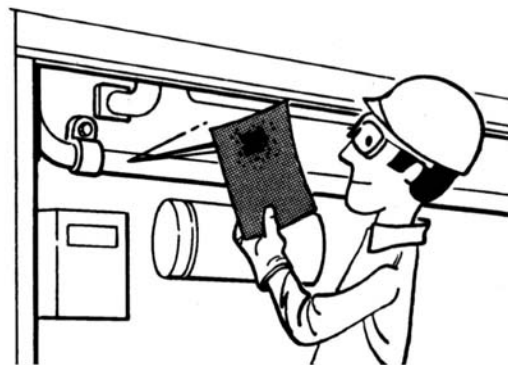

FIG. 42

## HYDRAULIC SYSTEMS (CONT'D)

If you are struck by escaping **hydraulic fluid under pressure**, serious injury can occur if proper medical treatment is not administered immediately.

During operation, hydraulic fluid and air in an **unvented hydraulic tank** becomes heated and will tend to expand. This will raise the pressure inside an unvented hydraulic tank. If the filler cap is removed rapidly, the pressure in the tank can force the oil out of the tank very rapidly. **The hydraulic fluid may be very hot and may cause severe burns.** Always relieve tank pressure before removing the cap completely. Consult the manufacturer's instructions for the correct procedure.

When adding fluid to any system, be sure to use the fluid recommended by the manufacturer. Certain fluids, when mixed, may destroy seals causing loss of control and possible personal injury.

Keep hydraulic relief valve settings set to the manufacturer's recommendations. **Excessive pressures** could result in structural or hydraulic failures. Low pressure could result in loss of control. Either condition could cause **personal injury or death.**

**Be sure the engine is stopped** and machine is properly locked out and controls tagged, before working on a machine. Only run engine when it is essential, as in the case of pressure adjustments, lubrication, or tests. Follow the manufacturer's recommendations when making adjustments. Never resume operation until satisfactory adjustments have been made. **The operator must** follow the mechanic's instructions when adjustments are being made or machine is being serviced.

# PERFORM MAINTENANCE SAFELY

## TIRE INSPECTION

Recommended air pressure **must be maintained** in every tire. Daily checks assure that inflation is correct. If your periodic check discloses a tire that is continuously losing air, a leak is indicated and must be repaired. (FIG. 43)

During your pressure checks, also inspect for:

- Objects wedged between or embedded in tires.
- Missing valve caps and wheel lugs.
- Cuts, tears, and breaks that may need repair.
- Abnormal or uneven wear.
- Damaged or poor fitting rim or rim flanges.
- Projecting body hardware, loose fender bolts, spring clips – anything that could contact a tire.

Do not burn or weld on wheels or rims.

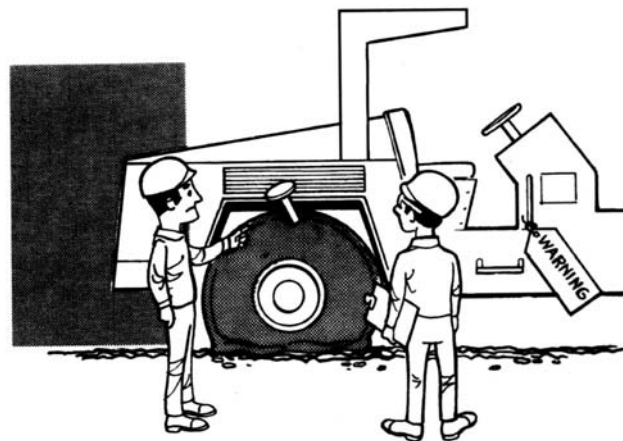

FIG. 43

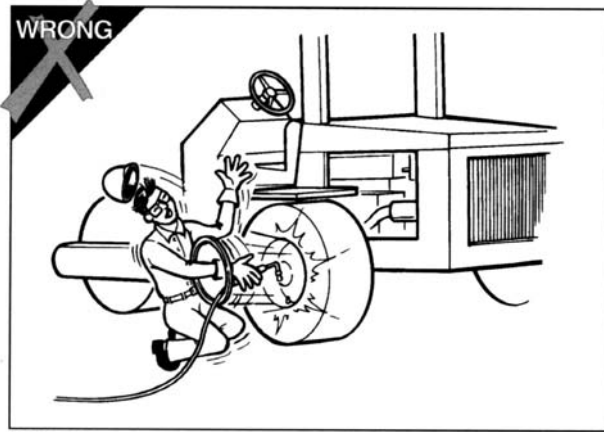

FIG. 44

## PNEUMATIC TIRES

Changing tires or adding air can be a hazardous business. Special tools and procedures are required for changing off-highway tires.

Explosion and separation of a tire and/or rim parts can cause serious injury or death. (FIG. 44) Always follow the manufacturer's recommendations or see your tire supplier.

## TIRE PRESSURE

Check tire pressure before starting operation. An air pressure rise during operation is normal and should NOT be reduced. Overloads or over-speeds may produce increased tire pressures due to heat. Never bleed tires. Reduce your load – or speed – or stop until tires cool.

## ADD AIR

From a distance – with air chuck clipped on the tire valve – and with extension hose that permits you to stand behind tread. (FIG. 45) Always use a tire cage or equivalent for protection.

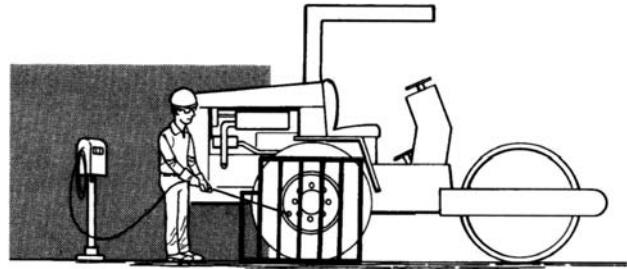

FIG. 45

# PERFORM MAINTENANCE SAFELY

## ROPS (Roll-Over Protective Structures)

Periodically inspect ROPS for cracks and loose mounting hardware.

Replace all missing, deteriorated or worn rubber parts.

If it becomes necessary to remove a ROPS, reinstall it only on the same machine, in its original position. (FIG. 46)

NEVER alter the ROPS in any way without the written approval of the manufacturer.

NEVER cut holes in or weld on ROPS without the manufacturer's approval.

NEVER attempt to repair a damaged ROPS – it must be replaced with a new unit, approved for that machine.

Periodically inspect seat belts for wear, tear, deterioration or excessive dirt. Replace them if necessary.

## AIR CONDITIONERS

NEVER attempt to weld on or near air conditioners. Poisonous gas may be formed when refrigerant gas is exposed to a flame or excessive heat.

Maintenance and repair of air conditioners ... except for very minor repairs or servicing ... must be done only by an experienced air conditioner or refrigeration technician. (FIG. 47)

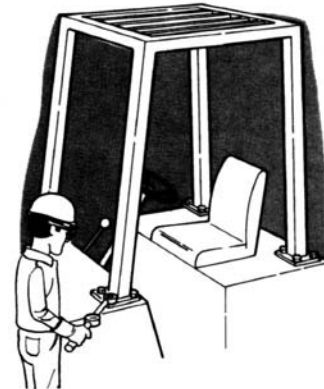

FIG. 46

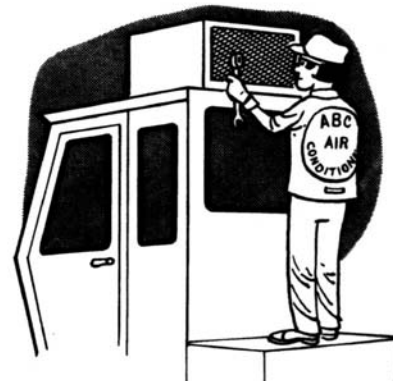

FIG. 47

# SPECIAL OPERATING AND MAINTENANCE PRECAUTIONS

## PARKING AND TRANSPORTING

ALWAYS select a level area to park in and, if possible, one where children are unlikely to be present. ALWAYS chock the front AND rear of the roller ... even if leaving the machine unattended for short periods.

ALWAYS use EXTRA care when towing a roller ... when maneuvering in tight places, when backing (visibility is reduced, and jackknifing must be avoided), and when operating on grades. NEVER operate a towed roller on steep grades or side slopes, as the possibility of tipping or loss of control is greater when towing a roller.

NEVER allow anyone to ride on a towed roller. And, unless absolutely necessary, never permit anyone in the "pinch" area between the towing vehicle and the towed roller.

When necessary to disconnect and park a towed roller, ALWAYS select a location which is level and, if possible, one where children are unlikely to be present. BEFORE disconnecting, ALWAYS chock the front AND rear of the roll, and block under the tongue.

Extreme care should be exercised when loading or unloading a walk-behind roller. It is generally best to stand behind and to one side rather than directly behind a machine being propelled up or down a ramp.

If the roller is designed to hang from the tailgate of a vehicle when being transported, ALWAYS be certain the hook brackets meet the roller manufacturer's specifications.

Special precautions must also be exercised when loading or unloading, transporting or servicing a towed roller. Consult your manufacturer's manual for specific details.

43

# SPECIAL OPERATING AND MAINTENANCE PRECAUTIONS

## FOR TOWED ROLLERS

Most general safety precautions covered earlier in this manual are also applicable to towed roller operation. Many other SPECIAL precautions must, however, be taken. Study your manufacturer's manual(s) relative to special considerations when towing. If you have questions or concerns, consult the manufacturer or your dealer.

ALWAYS use a tow tractor of sufficient weight, drawbar horsepower and braking capacity to properly control the towed roller. Proper weight balance and distribution is also essential.

ALWAYS block under the tongue of the towed roller BEFORE attempting to connect it to the towing vehicles or machine. NEVER attempt to lift heavy tongues or move towed rollers by hand. NEVER get any part of your body under the tongue when hitching or unhitching.

ALWAYS make sure the hitch pin is of the proper size, and securely locked in place before towing. (FIG. 48) If safety chains are provided, make sure they are properly and securely connected ... at BOTH ends. Cross the chains under the tongue when connecting to the towing vehicle. If electrical or hydraulic connections are required, make sure the connections are properly and securely made.

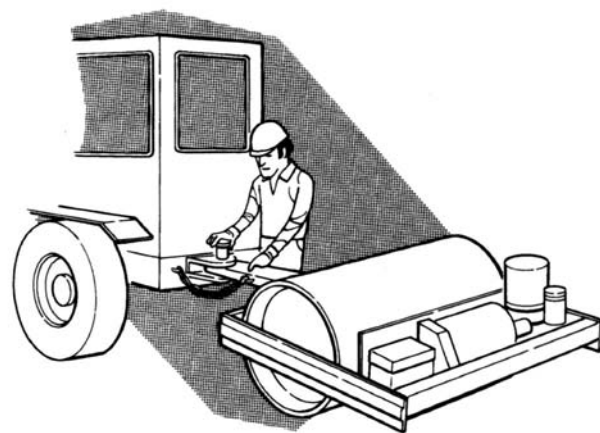

FIG. 48

# SPECIAL OPERATING AND MAINTENANCE PRECAUTIONS

## FOR LANDFILL COMPACTORS

### General

Operators of landfill compactors should carefully handle fill materials that could be picked up and thrown by the wheels, become lodged in the machine, or that are highly flammable.

Frequent checks should be made for wire, cable or other material wound around the axle members. Remove them immediately.

Travel with the blade as low as possible.

Maintain good operator visibility – keep all mesh and windows free of accumulated materials that reduce visibility.

When parking the machine, ALWAYS lower the blade.



FIG. 49

### FIRE PROTECTION

Maintain fire extinguishers and fire protective systems in good working order. ALWAYS recharge extinguishers, or replace with a fully charged unit immediately after use.

Check for, and remove, any waste material accumulation above belly pans and behind protective doors and grills. Accumulations are a fire hazard. (FIG. 49)

45

# SPECIAL OPERATING AND MAINTENANCE PRECAUTIONS

## FOR WALK-BEHIND ROLLERS

### Start-Up

NEVER attempt to operate a walk-behind roller before being thoroughly familiar with the manufacturer's operating instructions. If you have any questions or uncertainty, consult the manufacturer and/or his dealer BEFORE attempting to operate it.

ALWAYS follow the manufacturer's instructions for starting the engine. All controls MUST be in the correct position BEFORE attempting to start the engine ( for example, the shift lever must be in neutral).

Starting fluid is NOT recommended when hand starting an engine. The engine may kick back.

### OPERATION

When operating a walk-behind roller, ALWAYS exercise extreme care to avoid having your feet or clothing caught under the dolly wheels or roll. When possible, stand behind and to one side of the machine rather than directly behind it. Particular care must be exercised when operating near obstructions, on slippery surfaces, grades and side slopes. (ALWAYS wear slip resistant safety shoes or boots.)

NEVER ride on a walk-behind roller unless it is designed to accommodate riders and an appropriate seat is provided.

NEVER attempt to shift on a grade if the roller has a mechanical transmission.

NEVER operate a walk-behind roller in unshored trenches or near steep, unsupported banks. The vibrations could cause a cave-in.

Uneven grades can cause the handle to raise or lower unexpectedly, striking the unwary operator. (FIG. 50)

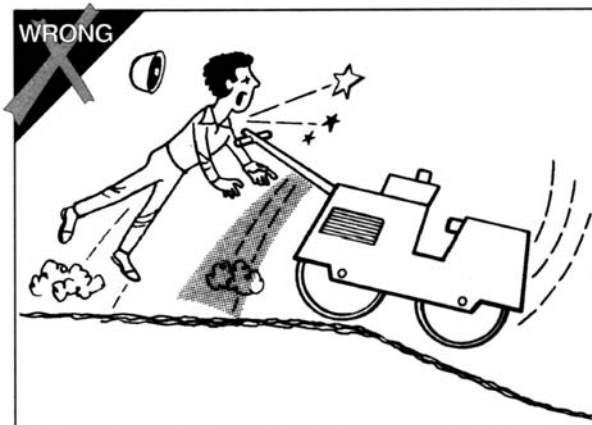

FIG. 50



Do you understand this AEM SAFETY MANUAL AND ITEMS SUCH AS ...

- Your safety program?
  - Your machine manufacturer's manual(s)?
  - Proper clothing and personal safety equipment?
  - Your machine's controls, warning signs and devices, and safety equipment?
  - How to properly inspect, mount, and start your machine?
  - How to check your machine for proper operation?
  - Your work area and any special hazards that may exist?
- Proper operating procedures?
  - Proper parking, shutdown, and dismounting procedures?
  - Proper maintenance procedures?
  - Proper loading and unloading procedures for transporting?
  - Under what conditions you should not operate your machine?

If you do not understand any of these items, consult with your supervisor BEFORE operating your machine!

## A FINAL WORD TO THE USER

**Remember that YOU are the key to safety.** Good safety practices not only protect you but protect the people around you.

You have read this safety manual and the manufacturer's manual(s) for your specific machine. Make them a working part of your safety program. Keep in mind that this safety manual is written for only this type of machine.

Practice all other usual and customary safe working precautions, and above all –

**REMEMBER  
SAFETY IS UP TO YOU  
YOU CAN PREVENT SERIOUS  
INJURY OR DEATH**

This manual is another in a series on the safe operation of machinery published by AEM.  
For additional publications visit our web site at [www.aem.org](http://www.aem.org).



**Association of Equipment Manufacturers**

Toll free 1-866-AEM-0442

e-mail [aem@aem.org](mailto:aem@aem.org)

[www.aem.org](http://www.aem.org)



10 Schematics

10.1 Electrical Schematic - Sheet 1

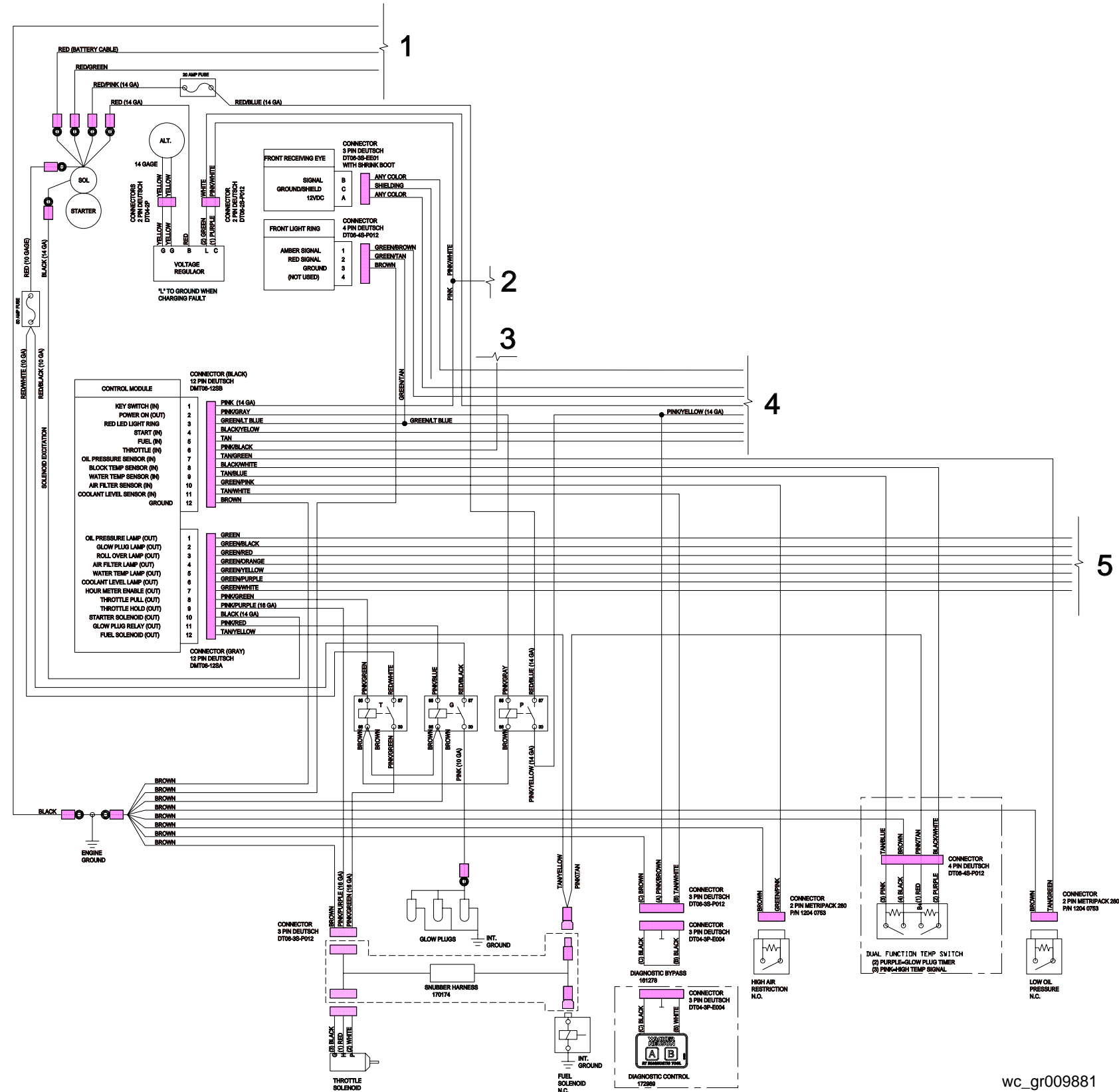

wc\_gr009881

10.2 Electrical Schematic - Sheet 2

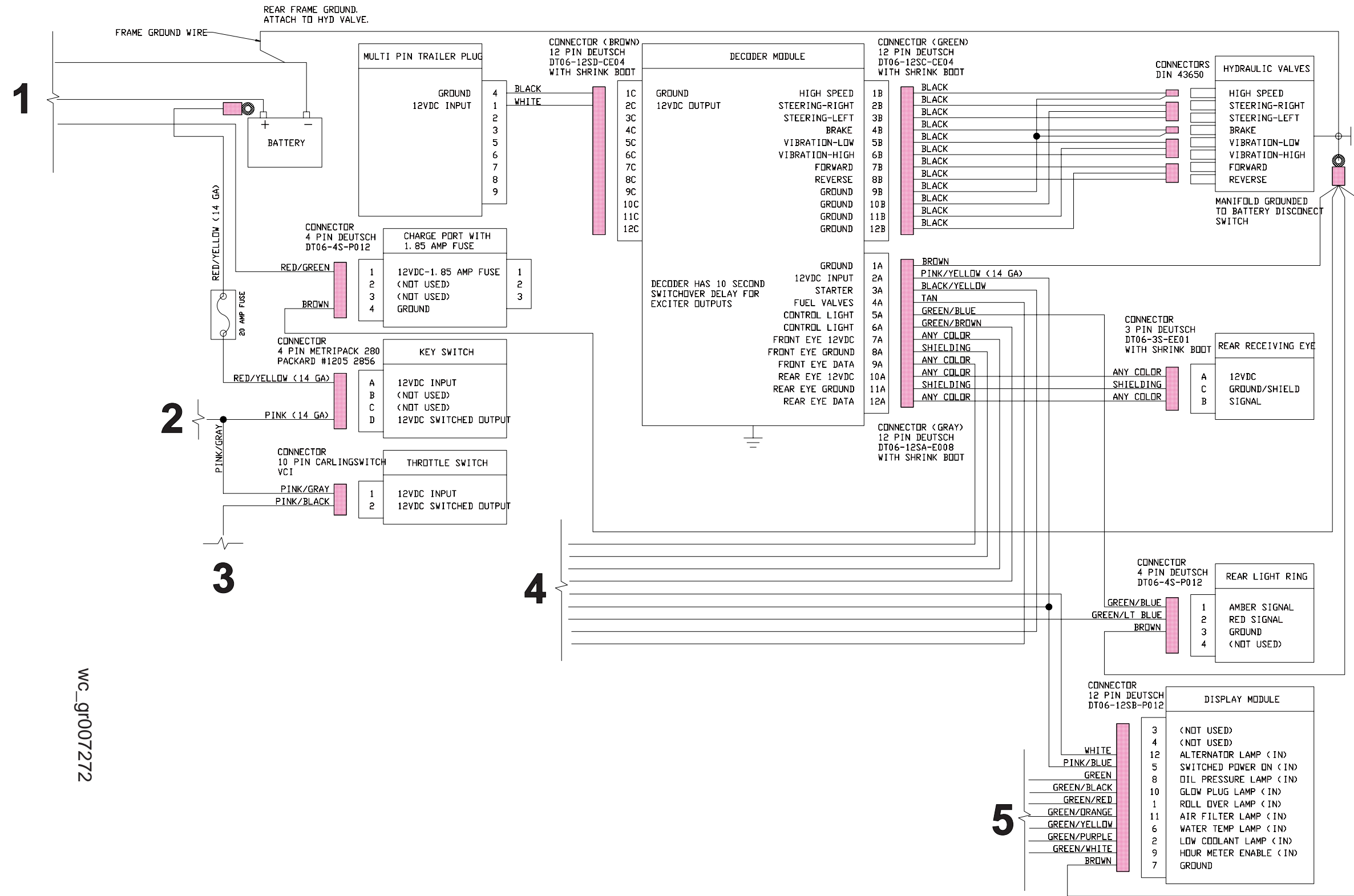

wc\_gr007272

## 10.3 Components

Below is an alphabetized listing of components shown on the electrical schematic. Use this as an aid when identifying electrical components.

English	
(Not used)	
"L" to ground when charging fault	
12VDC input	
12VDC input	
12VDC output	
12VDC switched output	
12VDC-1.85 Amp fuse	
20 Amp fuse	
50 Amp fuse	
5VDC input	
5VDC output	
Air filter lamp (in)	
Air filter lamp (out)	
Air filter sensor (in)	
ALT (alternator)	
Alternator lamp (in)	
Amber signal	
Any color	
Battery	
Battery cable	
Block temp sensor (in)	
Brake	
Brake (in 5V)	
Charge port with 1.85 Amp fuse	
Connector (black) 12-pin DEUTSCH	
Connector (black) 4-pin DEUTSCH	

English	
Connector (brown) 12-pin DEUTSCH with shrink boot	
Connector (gray) 12-pin DEUTSCH	
Connector (gray) 12-pin DEUTSCH with shrink boot	
Connector (gray) 2-pin DEUTSCH	
Connector (green) 12-pin DEUTSCH with shrink boot	
Connector 10-pin CARLINGSWITCH	
Connector 12-pin DEUTSCH	
Connector 2-pin DEUTSCH	
Connector 2-pin METRIPACK	
Connector 3-pin DEUTSCH	
Connector 3-pin DEUTSCH with shrink boot	
Connector 4-pin DEUTSCH	
Connector 4-pin METRIPACK	
Connectors DIN 43650	
Control light	
Control module	

English	
Coolant level lamp (out)	
Coolant level sensor (in)	
Coolant level switch	
Decoder has 10 second switchover delay for exciter outputs	
Decoder module	
Display module	
Dual-function temp switch	
Engine ground	
Forward	
Forward (in 5V)	
Forward (out 5V)	
Frame ground wire	
Front eye 12VDC	
Front eye data	
Front eye ground	
Front light ring	
Front receiving eye	
Fuel (in)	
Fuel solenoid (NC)	
Fuel solenoid (out)	
Fuel valves	
Fuel/brake (out 5V)	
Glow plug lamp (in)	
Glow plug lamp (out)	
Glow plug relay (out)	
Glow plugs	
Ground	
Ground/shield	

English	
High air restriction (NO)	
High speed	
Hour meter enable (in)	
Hour meter enable (out)	
Hydraulic valves	
Int. (intermediate) ground	
Key switch	
Key switch (in)	
Low coolant lamp (in)	
Low oil pressure (NC)	
Manifold ground to battery disconnect switch	
Multi-pin trailer plug	
Not used	
Oil pressure lamp (in)	
Oil pressure lamp (out)	
Oil pressure sensor (in)	
Pink=high temp signal	
Power on (out)	
Purple=glow plug timer	
Rear eye 12VDC	
Rear eye data	
Rear eye ground	
Rear frame ground. Attach to hydraulic valve	
Rear light ring	
Rear receiving eye	
Red LED light ring	
Red signal	
Reverse	
Reverse (in 5V)	

English	
Reverse (out 5V)	
Roll over lamp (in)	
Roll over lamp (out)	
Shielding	
Signal	
Signal	
Snubber harness	
SOL (solenoid)	
Solenoid excitation	
Start (in)	
Starter	
Starter (in 5V)	
Starter (out 5V)	
Starter solenoid (out)	
Steering-left	
Steering-right	
Steering-left (in 5V)	
Steering-left (out 5V)	
Steering-right (in 5V)	
Steering-right (out 5V)	
Switched power on (in)	
Throttle (in)	
Throttle hold (out)	
Throttle pull (out)	
Throttle solenoid	
Throttle switch	
Vibration-high	
Vibration-low	
Voltage regulator	

English	
Water temp lamp (in)	
Water temp lamp (out)	
Water temp sensor (in)	



Notes

10.4 Hydraulic Schematic

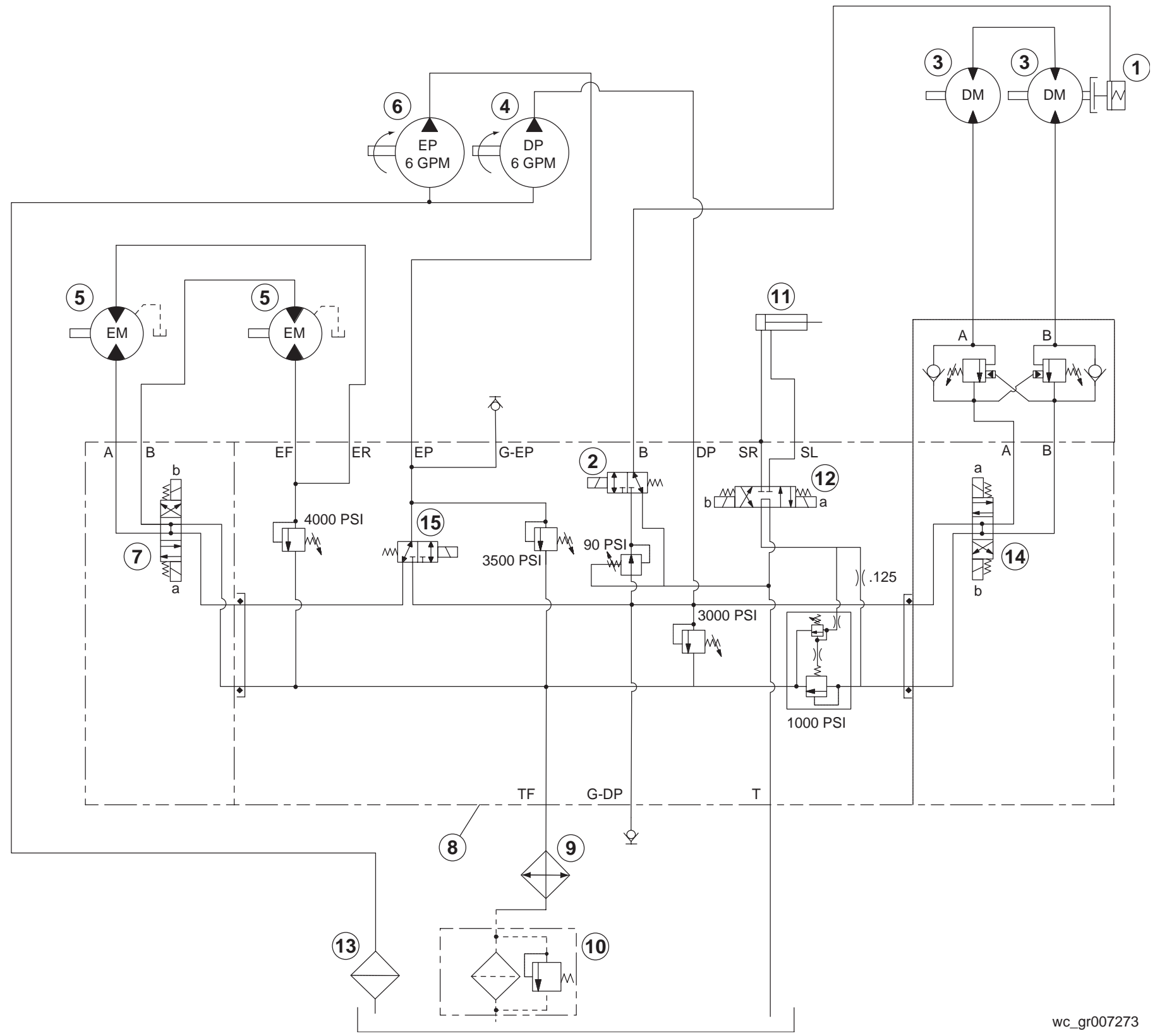

wc\_gr007273

## 10.5 Hydraulic Schematic Components

Ref.	Description	Ref.	Description
1	Parking brake	9	Oil cooler
2	Brake valve	10	Return line filter
3	Drive motor	11	Steering cylinder
4	Drive pump	12	Steering valve
5	Exciter motor	13	Suction strainer
6	Exciter pump	14	Travel valve
7	Exciter (vibration) valve	15	High-speed travel valve
8	Control manifold		





