

9 Tonne Front Tip

KEY FEATURES & BENEFITS - MACH2294



The Thwaites 9 Tonne Front Tip, Stage V dumper is manufactured with contractors and hirers in mind – ensuring operator safety, reducing risk on site, and improving performance. Front Tip dumpers allow the machine to be easily and safely unloaded, with a straightforward tipping action that places the full bucket of spoil exactly where it is required.

Powered by a 3.6L Deutz turbo diesel engine fitted with a DPF to comply with EU stage V emission regulations, you benefit from 55.4 kW peak power, 405 Nm of torque and no AdBlue requirement.

Thwaites 9 Tonne machines are available in a range of further configurations to suit your needs:

- › Front Tip with Cab
- › Power Swivel

A Spring Activated Hydraulic Release (SAHR) Handbrake, 5" screen displaying 150° around machine visibility, hi-vis steps, LED road lights and twin LED beacons are available across the 9 Tonne range.

Safe, compliant and competitive.



Snap this QR code from your smart phone for more information



Thwaites

Thwaites Ltd, Leamington Spa,
Warwickshire, CV32 7NQ, England
Tel +44 (0)1926 422471

www.thwaitesdumpers.co.uk



GET THE JOB DONE.

9 Tonne Front Tip

DIMENSIONS & SPECIFICATIONS - MACH2294

(mm)

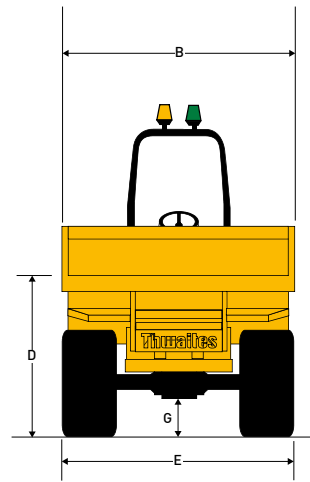
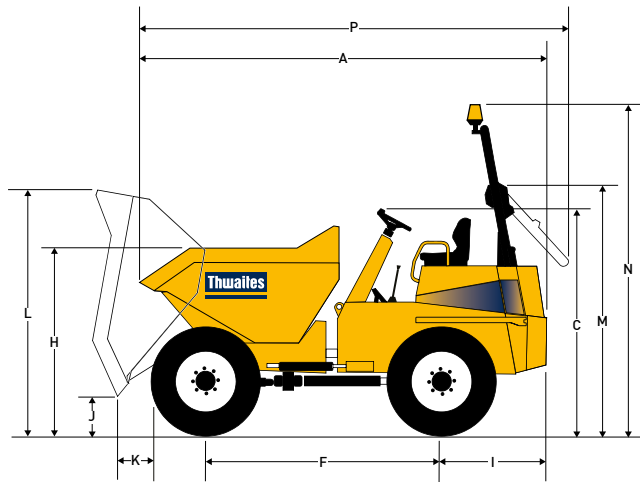

A	4670	N	3530
B	2485	P	5014
C	2440		
D	1740		
E	2444		
F	2615		
G	447		
H	1975		
I	1255		
J	436		
K	642		
L	2840		
M	2555		

Weight	Unladen	4870 kg
	Shipping	4746 kg

Capacities	Max safe load	9000 kg
	Heaped	4600 litres
	Struck	3830 litres
	Water	2155 litres

Engine

- > Deutz TCD 3.6 L4, water-cooled, 4-cylinder, charged air cooled turbo, fuel injected diesel and after treatment Diesel Particulate filter
- > Power 55.4 kW/ 74 bhp at 2200 rpm
- > Torque 405 Nm (299 lbf ft).

Noise Levels

- > Operator's ear 84 LpA / airborne level 101 LwA

Transmission

- > Torque converter four speed forward and reverse Powershift transmission, column mounted speed and directional control lever

Speeds	Forward and Reverse	
	1	4.2 km/h (2.6 mph)
	2	7.5 km/h (4.6 mph)
	3	13.7 km/h (8.5 mph)
	4	24.3 km/h (15 mph)

Brakes and Axles

- > Totally enclosed multiplate oil-immersed discs mounted on both axles & auto wear adjustment
- > Hand operated parking brake (SAHR)

Kinglink Chassis

- > Constructed from folded steel plate, with three point Kinglink giving articulation and oscillation for better stability, traction and safety on site

Skip

- > Hydraulically operated, 6 mm steel base plate
- > Skip mouth & sides reinforced with box sections

Seating & Controls

- > Adjustable suspension seat with high-vis seat belt
- > Clear operators display unit contains all warning lamps

Service Access

- > Lockable engine cover for ground level service points
- > Rear chassis panel can be hinged back on retainers

Electrics

- > Fuse & relay are housed on a central power distribution board
- > Main harness is fully enclosed in solid conduit and incorporates the engine diagnostic port

Steering and Hydraulics

- > Hydraulic power steering
- > Return line filtration for all services
- > Hydraulic test point fitted as standard

Tank Capacities	Fuel	72 litres
	Hydraulic	50 litres

Turning Circle	14m
-----------------------	-----

Standard Equipment

- > Camera and dashpanel monitor
- > LED beacons
- > Fan guard
- > Reverse alarm

Optional Equipment

- > Full LED road lighting incl. DRL (Daylight Running Lights)
- > Road mirrors
- > Wheel nut indicator
- > GPS speedometer

Thwaites

Thwaites Ltd, Leamington Spa,
Warwickshire, CV32 7NQ, England
Tel +44 (0)1926 422471

www.thwaitesdumpers.co.uk



Images are representative, but specific details or equipment may vary by country. We reserve the right to change any and all specifications without prior notice. 11/2021