

OPERATOR'S MANUAL

Original instructions

TB285

Serial No. 185000001~

TB290

Serial No. 190000001~

Book No. AM1E005

OE-TB285-F

HYDRAULIC EXCAVATOR

TAKEUCHI



WARNING Read and understand these instructions.
Failure to do so can cause injury or death.

SAFETY ALERT SYMBOL



This symbol represents the safety alert. The message that follows the symbol contains important information about safety.

Read and understand the message to avoid personal injury or death.

It is the owner or employer's responsibility to fully instruct each operator in the proper and safe operation of all equipment. All persons using this machine should thoroughly familiarize themselves with the contents of this manual.

All operators must be instructed on the proper functions of the excavator before running the machine.

Learn and practice correct use of the machine controls in a safe, clear area before operating this machine on a job site.

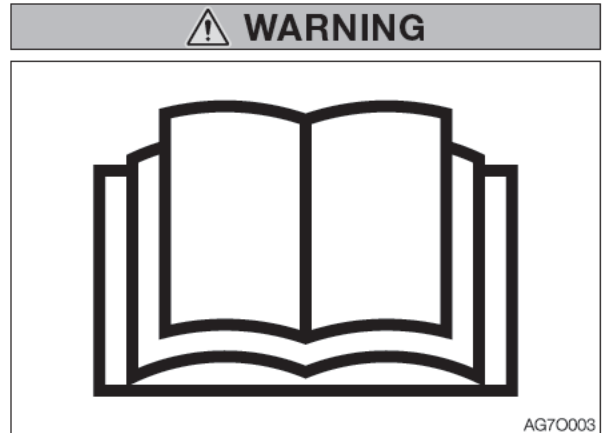

Improper operation, inspection and maintenance of this machine can cause injury or death.

Read and understand this manual before performing any operation, inspection or maintenance on this machine.

Always store this manual near at hand preferably on the machine itself. If it should be lost or damaged, immediately order a new one from your Takeuchi dealer. When transferring ownership of this machine, be sure to hand this manual to the next owner.

Takeuchi supplies machines complying with the local regulations and standards of the country of export. If your machine has been purchased in another country or from a person or company of another country, it may not have the safety devices or safety standards required for use in your country. Should you have any question about whether your machine complies with the regulations and standards of your country, contact a Takeuchi dealer.

SIGNAL WORDS

Safety messages appearing in this manual and on machine decals are identified by the words “DANGER”, “WARNING” and “CAUTION”. These signal words mean the following:

DANGER

DANGER indicates a hazard with a high level of risk which, if not avoided, will result in death or serious injury.

WARNING

WARNING indicates a hazard with a medium level of risk which, if not avoided, could result in death or serious injury.

CAUTION

CAUTION indicates a hazard with a low level of risk which, if not avoided, could result in minor moderate injury.

IMPORTANT: The word **IMPORTANT** is used to alert operators and maintenance personnel about situations which could result in damage to the machine and its components.

It is impossible to foresee every possible circumstance that might involve a potential hazard. The warnings in this manual or on the machine can not cover all possible contingencies. You must exercise all due care and follow normal safety procedures when operating the machine so as to ensure that no damage occurs to the machine, its operators or other persons.

INTRODUCTION

FOREWORD

This manual describes operation, inspection and maintenance of the machine, as well as safety instructions to be heeded during these operations.

If you have any questions about the machine, please contact a Takeuchi sales or service outlet.

MANUAL STORAGE COMPARTMENT

A compartment for storing this manual is provided at the position shown on the diagram below.

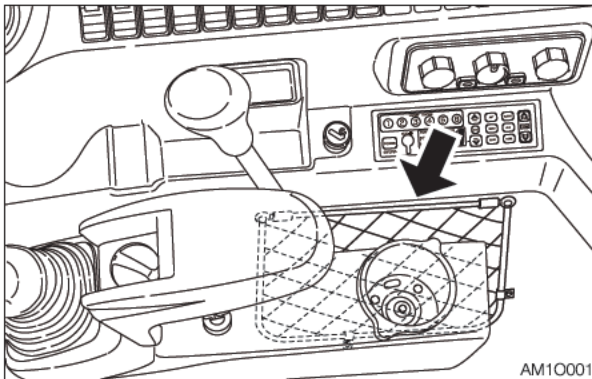

1. After using the manual, place it in the plastic pouch and store it back in the manual storage compartment.

SERIAL NUMBERS

IMPORTANT: Do not remove the machine name plate with the serial number. Check the serial numbers of the machine and engine and write them down in the spaces below.

Machine number:

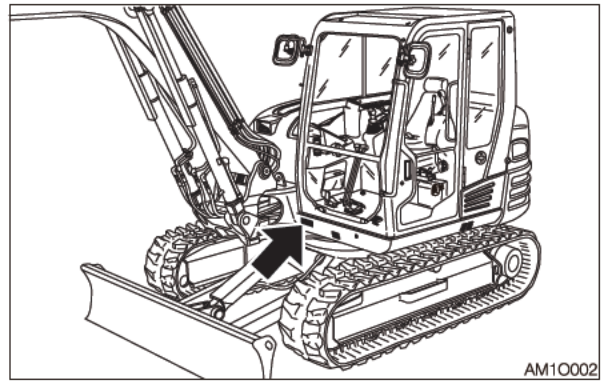

Engine number:

<TB285>

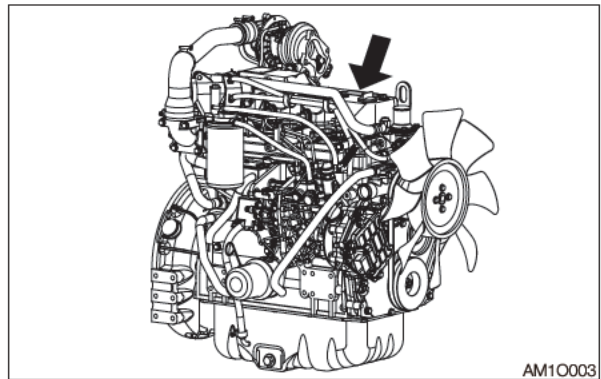

<TB290>

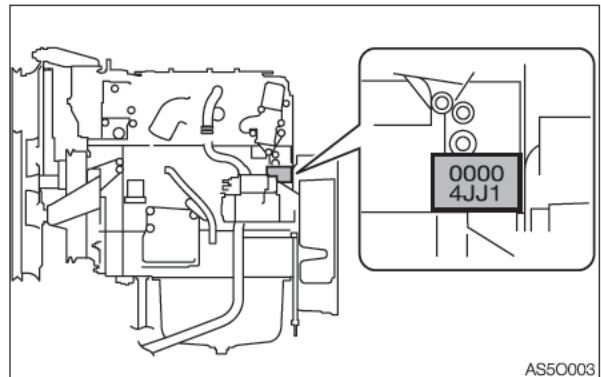

MACHINE DESCRIPTION

FRONT, REAR, LEFT AND RIGHT

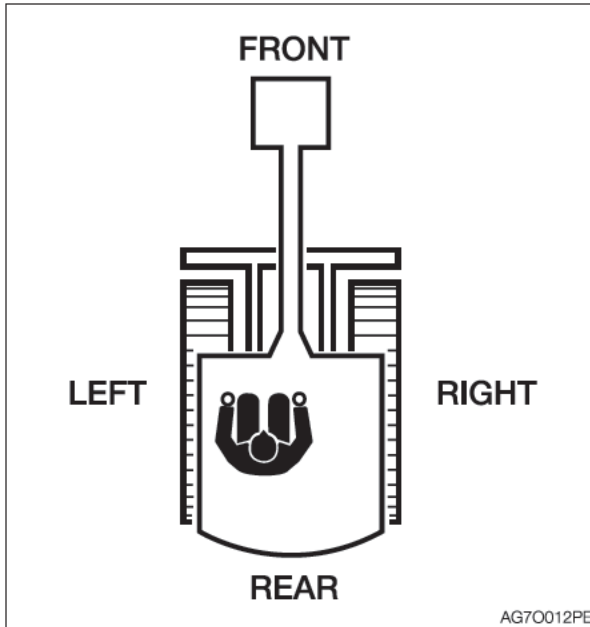

This manual refers the front, rear, left and right of the machine as seen when sitting in the operator's seat with the dozer blade visible to the front.

DESIGNATED OPERATIONS

Use this machine primarily for the following operations:

- Excavation
- Digging ditches
- Digging side ditches
- Leveling
- Loading

FEATURES

- Hydromounted cab minimizes vibration
- Automatic travel shift-down system
- Self-adjusting shoe tension system
- Short pitch rubber crawler
- Low engine noise and exhaust emissions
- Electronic control of auxiliary hydraulic circuit
- Automatic and manual operation for engine deceleration
- Engine emergency stop system

BREAK-IN PERIOD

When the machine is new, operate the machine for the first 100 hours (as indicated on the hour meter) by following the instructions below.

Using a new machine without a break-in period will lead to quicker deterioration of machine performance and may shorten the machine's service life.

- Sufficiently warm up the engine and hydraulic oil.
- Avoid heavy loads and rapid operations. Operate with a load of about 80% the maximum load.
- Do not abruptly start up, accelerate, change directions, or stop unless necessary.

NOTES ON READING THIS MANUAL

Please note that the descriptions and diagrams included in this manual may not be applicable to your machine.

The numbers used in the illustration are with circles around them. The same numbers appear between the parentheses in the text.
(Example: ① → (1))

Symbols used in this manual

The symbols used in this manual have the following meanings.

⊘, X Prohibition

🔒 Lock

🔓 Unlock

CONTENTS

Introduction	0-2	Third auxiliary hydraulic button	2-27
Machine description	0-3	Auxiliary 2/4 select button	2-27
Safety	1-1	Wiper switch	2-28
General precautions	1-2	Washer switch	2-28
Precautions when preparing	1-8	Automatic deceleration switch	2-28
Precautions when starting	1-10	ECO mode switch	2-29
Precautions when operating	1-12	Highland mode switch	2-29
Precautions when stopping	1-21	Auxiliary 1st flow select switch	2-29
Precautions when transporting	1-22	Detent mode switch (Auxiliary 1st)	2-29
Precautions on maintenance	1-24	Light switch	2-30
Safety signs (decals)	1-33	Overload warning switch	2-30
Controls	2-1	Beacon lamp switch	2-30
Names of components	2-2	Levers and Pedals	2-31
Covers	2-4	Safety lock lever	2-31
Starter key	2-4	Operating levers	2-31
Side cover	2-4	Blade lever	2-32
Fuel lid	2-5	Travel levers/pedals	2-33
Fuel filler port	2-5	Boom swing pedal	2-33
Engine hood	2-6	Accessories	2-34
Fuse box cover	2-6	Air conditioner	2-34
Cab	2-7	Cup holder	2-39
Cab door	2-7	Cigarette lighter	2-40
Emergency exit	2-7	Ashtray	2-40
Front window	2-8	Interior light	2-41
Lower front window	2-9	Mirrors	2-41
Side window	2-9	External power sockets	2-41
Emergency hammer (optional)	2-9	Radio (for cab)	2-42
Seat and seat belt	2-10	Auxiliary hydraulic lines	2-46
Seat	2-10	Operating the machine with an	
Seat belt	2-11	accumulator	2-51
Air Suspension Seat	2-12	Load safety device	2-52
Instrument cluster	2-16	Overload warning device	2-53
Warning lamps	2-16	Fuel Supply Pump	2-54
Indicators	2-17	Operation	3-1
Meters	2-17	Before starting operation	3-2
Multi-data display	2-18	Getting on or off the machine	3-2
Switches	2-24	Walk-around inspection	3-2
Starter switch	2-24	Daily inspection	3-2
Engine shutdown switch	2-24	Starting and stopping the engine	3-3
Throttle controller	2-24	Before starting the engine	3-3
Horn button	2-25	Starting the Engine	3-4
Deceleration button	2-25	Warming up the engine	3-5
Travel speed button	2-25	Stopping the engine	3-5
Auxiliary 1st switch	2-26	Operating the machine	3-6
Auxiliary 2nd/4th switch	2-26	Lever pattern (ISO pattern)	3-6
Swing/Second boom select button	2-27	Lever pattern (JCB pattern)	3-7
		Warming up the machine (hydraulic oil)	3-8
		Inspection after warm-up	3-9
		Operating the travel levers	3-10

Stopping travel	3-13
Operating the working equipment	3-14
Operating procedures.....	3-16
Prohibited operations.....	3-16
Cautions on operating	3-19
Cautions on traveling	3-19
Cautions on traveling on slopes	3-20
Getting out of mud	3-22
Operations possible with this machine.....	3-22
Parking the machine.....	3-24
Parking	3-24
Inspection and checks after stopping the engine.....	3-24
Handling in cold climates.....	3-25
Preparing for cold climates	3-25
Cautions after operations.....	3-25
After the cold climate.....	3-25
Handling rubber crawlers.....	3-26
Prohibitions.....	3-26
Cautions.....	3-27
Preventing the rubber crawlers from coming off	3-27

Transport4-1

Loading and unloading	4-2
Hoisting the machine	4-4
Securing the machine.....	4-6

Maintenance5-1

General.....	5-2
Maintenance overview	5-2
Cautions on maintenance	5-2
Service data	5-4
Fuel and lubricant table.....	5-4
Regularly replace the hydraulic oil	5-6
List of consumables.....	5-7
List of tools.....	5-8
List of tightening torques	5-9
Safety-critical parts.....	5-10
Maintenance list.....	5-12
Walk-around inspection	5-14
Inspecting by opening the engine hood and covers.....	5-14
Inspecting by walking around the machine.....	5-15
Inspecting while sitting in the operator's seat.....	5-15
Daily inspection (every 10 hours).....	5-16

Inspecting and replenishing the coolant	5-16
Inspecting and replenishing the engine oil	5-17
Inspecting the water separator and the fuel filters	5-18
Inspecting the fuel level.....	5-19
Inspecting the hydraulic oil tank level and replenishing	5-20
Lubricating the working equipment ...	5-21
After the initial 50 hours (only for new machines)	5-22
Replacing the engine oil and the oil filter	5-22
Inspecting and adjusting the fan belt..	5-24
Inspecting and adjusting the compressor belt (AC)	5-26
Every 50 hours	5-28
Inspecting the crawler belt tension....	5-28
Lubricating the slew bearing	5-30
Draining the water from the fuel tank..	5-31
Inspecting the battery fluid level and replenishing	5-32
After the initial 250 hours (only for new machines)	5-34
Replacing the hydraulic oil return filter	5-34
Replacing the pilot line filter.....	5-35
Replacing the travel motor gear oil....	5-36
Every 250 hours	5-37
Replacing the engine oil and the oil filter	5-37
Inspecting and adjusting the fan belt..	5-37
Inspecting and adjusting the compressor belt (AC)	5-37
Cleaning the air cleaner	5-38
Cleaning the radiator fins and oil cooler fins.....	5-39
Cleaning the air filters (air conditioner)	5-40
Cleaning the condenser (AC)	5-41
Inspecting the refrigerant (gas) level (AC)	5-42
Every 500 hours	5-44
Replacing the fuel filter	5-44
Replacing the water separator filter <TB285>	5-46
Replacing the feed pump filter <TB290>	5-47
Every 1000 hours	5-48
Replacing the hydraulic oil return filter	5-48
Replacing the pilot line filter.....	5-48

Replacing the travel motor gear oil.....	5-48
Cleaning the engine cooling system...	5-48
Replacing the air cleaner element	5-50
Replacing the air breather filter	5-51
Inspecting and adjusting the engine valve clearance	5-51
Retightening the engine cylinder head bolt <TB285>	5-51
Inspecting the engine compression pressure <TB290>.....	5-51
Inspecting and cleaning the engine starter and the alternator <TB290>....	5-51
Every 1500 hours	5-52
Inspecting and cleaning the engine fuel injectors <TB285>.....	5-52
Inspecting the crankcase breather system <TB285>	5-52
Every 2000 hours	5-53
Lapping the engine valve seats <TB285>	5-53
Every 4000 hours	5-54
Replacing the hydraulic oil and cleaning the suction strainer	5-54
When required	5-58
Replacing the bucket teeth and the side cutters.....	5-58
Replacing the bucket.....	5-60
Adjusting the gap between the bucket and arm (If equipped)	5-62
Inspecting and replenishing the windshield washer fluid	5-63
Draining the water from the water separator	5-63
Lubricating the levers and pedals.....	5-64
Inspecting the rubber crawlers.....	5-65
Replacing the rubber crawlers	5-66
Maintenance during extended storage period.....	5-68

Troubleshooting6-1

Symptoms that are not malfunctions	6-2
If the engine overheats.....	6-3
If the battery goes dead.....	6-4
If a fuse blows	6-6
Inspecting and replacing the fuse.....	6-6
Inspecting the fusible link	6-7
Restarting after adding fuel	6-8
Bleeding air from the fuel system	6-8
If a warning lamp flashes	6-10
Vehicle error code list.....	6-12

Engine error code list.....	6-14
Other symptoms.....	6-18
Lowering the boom to the ground	6-20
Towing.....	6-21

Specifications7-1

Basic Specifications.....	7-2
Machine dimensions.....	7-4
Operating ranges.....	7-8
Lifting Capacities	7-13

Options8-1

General precautions	8-2
Safety precautions	8-2
Cautions when installing attachments ..	8-2
Cautions when operating attachments ..	8-3
Attachment combination table	8-4
Selecting a lever pattern	8-5
Switching the lever pattern	8-5
Hydraulic breaker	8-6
Cautions on operating	8-6
Replacing the hydraulic oil regularly	8-7
Travel alarm	8-8
Optional equipment mass	8-9
Biodegradable oil.....	8-10
Replacing the hydraulic oil with biodegradable oil	8-10
Cab options.....	8-11
Angle dozer blade.....	8-12
Operating lever switch kit 1.....	8-13
Horn button.....	8-13
Deceleration button	8-13
Travel speed button	8-13
Auxiliary 1st switch	8-14
Auxiliary 2nd/4th switch.....	8-14
Auxiliary 2/4 select button.....	8-15
Swing/Second boom select button....	8-15

SAFETY 



GENERAL PRECAUTIONS

It is your responsibility to observe all pertinent laws and regulations and to follow the manufacture's instructions on machine operation, inspection and maintenance.

Virtually all accidents occur as the result of a failure to observe basic safety rules and precautions.

Most accidents can be prevented by identifying the potentially hazardous situations beforehand.

Read and understand all safety messages which describe how to prevent accidents. Do not operate the machine until you are sure that you have gained a proper understanding of its operation, inspection and maintenance.

Observe all safety rules

- Operation, inspection and maintenance of this machine must be performed only by a trained and qualified person.
- All rules, regulations, precautions and safety procedures must be understood and followed when performing operation, inspection and maintenance of this machine.
- Do not perform any operation, inspection and maintenance of this machine when under the adverse influence of alcohol, drugs, medication, fatigue, or insufficient sleep.

When a problem is found on the machine

If any problem (noise, vibration, smell, disorder of instrument, smoke, oil leak, wrong indication of alarm or unusual indication in the instrument cluster, etc.) is detected during the operation or inspection and maintenance of the machine, immediately inform your sales or service dealer and take proper actions. Do not operate the machine until the trouble is cleared.

Operating temperature range

To maintain the performance of machine and to prevent it from early wear, observe the following operating conditions.

- Do not operate the machine if the ambient temperature is higher than +45°C (+113°F) or lower than -15°C (+5°F).
 - If operated at an ambient temperature of higher than +45°C (+113°F), the engine may overheat and cause the engine oil to degrade.
 - If operated at an ambient temperature of lower than -15°C (+5°F), the parts made of rubber such as gaskets may get hardened to cause an early wear or damage to the machine.
 - If the machine is to be used outside the ambient temperature range described above, consult your sales or a service dealer.



SAFETY GENERAL PRECAUTIONS

Wear appropriate clothing and protective equipment



- Do not wear loose clothing or any accessory that can catch on controls or in moving parts.
- Do not wear oily or fuel stained clothing that can easily catch fire.
- Wear a hard hat, safety shoes, safety glasses, filter mask, heavy gloves, ear protection and other protective equipment as required by job conditions. Wear required appropriate equipment such as safety glasses and filter mask when using grinders, hammers or compressed air, as metal fragments or other objects can fly and cause serious injury.
- Use hearing protection when operating the machine. Loud prolonged noise can cause hearing impairments, even the total loss of hearing.

Install a fire extinguisher and first aid kit

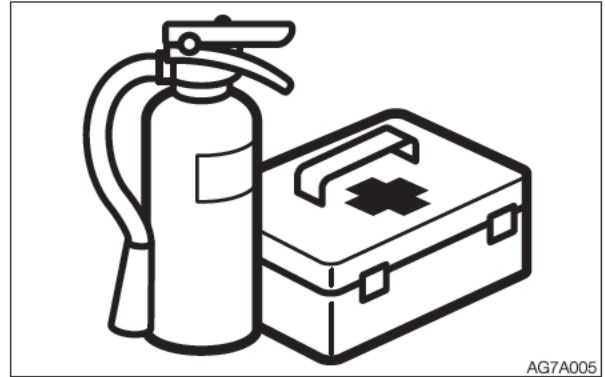

Be prepared for fire and accidents

- Install an extinguisher and a first aid kit, and learn how to use them.
- Learn how to fight a fire and how to deal with accidents.
- Know how to contact emergency assistance and make a list of emergency contacts.

Never remove safety equipment

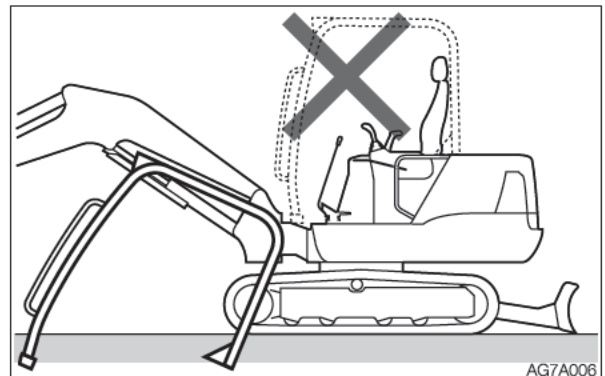

- Make sure all protective guards, covers and doors are in place and secured. Repair or replace damaged parts before operating the machine.
- Know how to use the safety lock lever, seat belt and other safety equipment and use them properly.
- Never remove any safety equipment except for servicing. Keep all safety equipment in good operating condition.



SAFETY GENERAL PRECAUTIONS

Use a signal person and a flag person

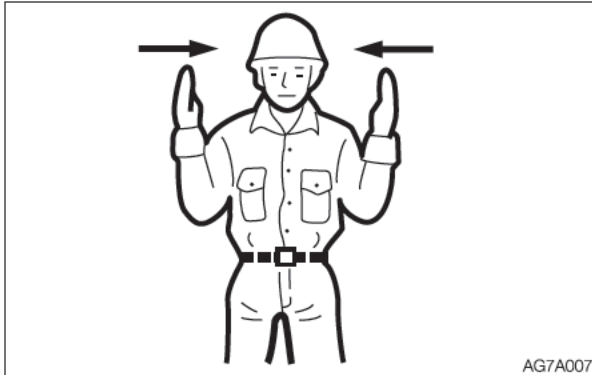

Learn how to use the hand signals required for particular jobs and make sure who has the responsibility for signaling.

- All personnel must fully understand all the signals.
- The operator must respond to signals only from the appointed signal person, but must obey a stop signal at any time from anyone.
- The signal person must stand in a clearly visible location when giving signals.

Cautions when standing up from or leaving the operator's seat

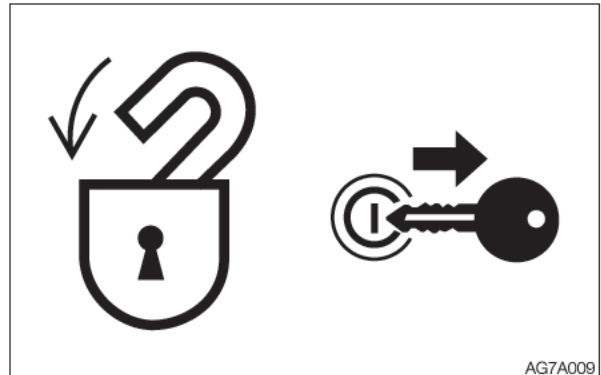

- Before standing up from the operator's seat to open/close the window or remove/install the lower window, lower the working equipment to the ground, raise the safety lock levers to engage the lock and stop the engine. If any controls should be accidentally touched when the safety lock levers is lowered (unlocked), the machine will suddenly move and cause serious injury or death.
- Be careful not to touch the operating levers when raising or lowering the safety lock levers.
- Before leaving the operator's seat, lower the working equipment to the ground, raise the safety lock levers to engage the lock and stop the engine. Also, be sure to remove the key, lock the door and covers, take it with you and store it in a specified place.



SAFETY GENERAL PRECAUTIONS

Avoid fire and explosion hazards



Keep flames away from fuel, oil, grease and antifreeze. Fuel is particularly flammable and dangerous.

- When handling these combustible materials, keep lit cigarettes, matches, lighters and other flames or sources of flames away.
- Do not smoke or permit open flames while handling fuel or working on the fuel system.
- Do not leave the location while refilling with fuel or oil.
- Never remove the fuel cap or add fuel when the engine is running or still hot. Also, do not spill the fuel on the hot surface of the machine or the component of the electric system.
- Clean up spilled fuel or oil immediately.
- Check for fuel, oil leak. Stop all leaks and clean the machine before operating.
- When operating with grinder or welding, move inflammables to a safe place.
- Do not cut or weld on pipes or tubes that contain flammable fluids. Clean thoroughly with nonflammable solvent before cutting or welding.
- Remove all trash or debris from the machine. Make sure that oily rags or other flammable material are not stored on the machine.
- Handle all solvents and dry chemicals (foam type fire extinguisher) according to procedures identified on manufacturer's containers. Work in a well-ventilated area.
- Never use fuel for cleaning purposes. Always use a nonflammable solvent.

- When handling the fuel, washing oil or paint, open the door and windows to ventilate thoroughly.
- Store all flammable fluids and materials in a safe and well-ventilated place.
- The short circuit of the electric system may cause the fire. Check for any loosened connections or damage to the wires every day. Retighten the loosened connector and wire clamp. Fix or change the damaged wire.
- Fire from the pipes:
Make sure that the clamps, guards and cushions of the hoses and tubes are securely fixed. If not, hoses or tubes may be damaged due to vibration or contact with other parts during operation. This can cause the high-pressure oil to spurt out, resulting in the fire or injury.



SAFETY GENERAL PRECAUTIONS

Exhaust fumes from the engine is poisonous

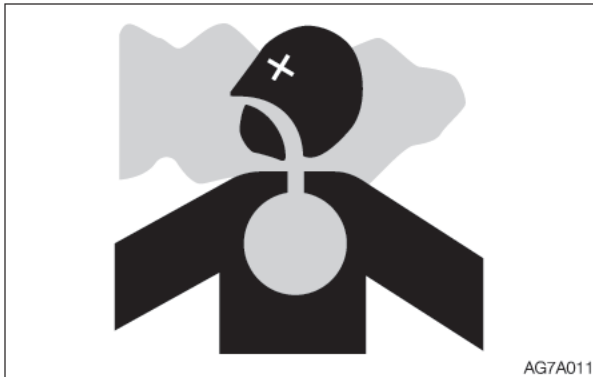

- Do not operate the engine in an enclosed area without adequate ventilation.
- If natural ventilation is not possible, install ventilators, fans, exhaust extension pipes or other venting devices.

Handling asbestos dust

Inhaling asbestos dust can cause lung cancer. When handling the materials which may contain asbestos, take the following precautions:

- Never use compressed air for cleaning.
- Avoid brushing or grinding parts containing asbestos.
- For clean up, use a vacuum equipped with a high efficiency particulate air filter (HEPA).
- Wear the stipulated respirator if there is no other way to control the dust. When working indoors, install a ventilation system with a macromolecular filter.
- Do not allow unauthorized personnel in the work area while working.
- Follow the rules and environmental standard applicable to the work area.

Be careful not to get crushed or cut



Never put your hands, feet or other parts of your body between the upperstructure and the undercarriage or tracks, between the machine body and working equipment, or between a cylinder and moving part. The sizes of these gaps change when the machine moves, and a person can suffer severe injury or death.



SAFETY
GENERAL PRECAUTIONS

Using optional products

- Consult with Takeuchi before installing optional attachments. Depending on the type of attachments or the combination of them, the attachment may come into contact with the operator's compartment or the other parts of the machine. Make sure that the optional attachment installed is not contacted with other parts before use.
- Do not use attachments that have not been approved by Takeuchi. Doing so may compromise safety or adversely affect the machine's operation or service life.
- Takeuchi will not be held responsible for any injuries, accidents or damage to its products caused by the use by a non-approved attachment.

Never modify the machine

Unauthorized modifications to this machine can cause injury or death. Never make unauthorized modifications to any part of this machine.



PRECAUTIONS WHEN PREPARING

Know the work area

Before starting operation, know the working area condition to ensure a safety operation.

- Inspect the topography and ground condition of the working area, or the structure of the building when working indoors, and take the safety precautions as necessary.
- Be sure to avoid all hazards and obstructions such as ditches, underground lines, trees, cliffs, overhead electrical wires, or places where there is a danger of falling rocks or slides.



- Check with the administrator for the locations of buried gas pipes, water pipes and power cables. If necessary, determine what specific precautions must be taken to insure safety by consulting with the administrator.
- When working on roads, be sure to consider the safety of pedestrians and vehicles.
 - Use a flag person and/or a signal.
 - Fence off the working area and keep off unauthorized persons.
- When working in water or crossing shallow streams or creeks, check the depth of the water, the solidity of the ground and the water flow speed beforehand. Refer to “Cautions on operating” for further instructions.

Check the strength of the bridge

When traveling over a bridge or a structure, check the permissible load. If the strength is insufficient, reinforce the bridge or the structure.

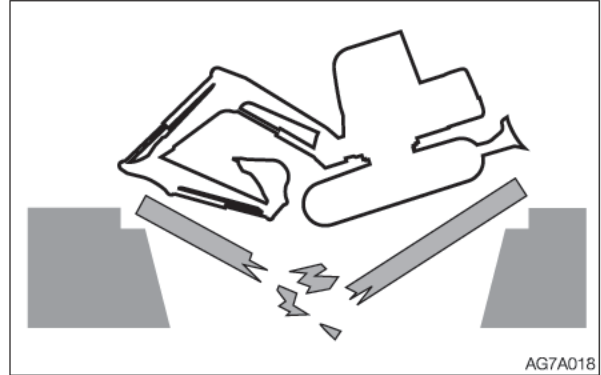

Always keep the machine clean

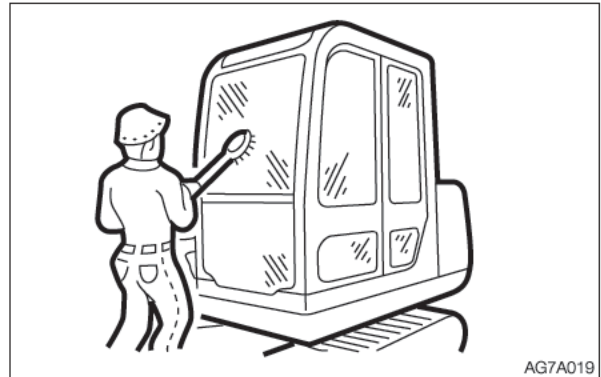

- Clean windows, mirrors and lights to ensure good visibility. Adjust the mirror to the best position for the operator to see the rear view (blind spot) from the operator's seat.
- Wipe off any oil, grease, mud, snow or ice, to prevent accidents due to slipping.
- Remove all loose objects and unnecessary devices from the machine.
- Remove any dirt, oil or grease from the engine area to prevent fires.
- Clean around the operator's seat and remove any unnecessary object from the machine.



SAFETY PRECAUTIONS WHEN PREPARING

Perform inspection and maintenance every day

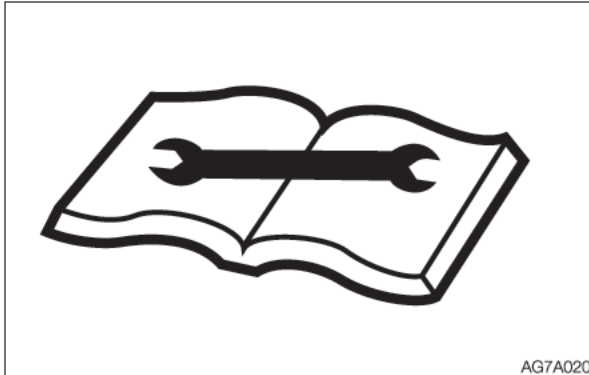

Failure to identify or repair the irregularities or damage on machine can lead to accidents.

- Before operating, perform the specified inspection and make prompt repairs where necessary.
- If a failure occurs and the operation becomes impossible or the engine fails, immediately stop the machine by following the shutdown procedure, and keep machine securely parked until the malfunction is corrected.

Cautions in the operator's compartment

- Remove mud and grease from shoe soles before entering the operator's compartment. Pedaling the machine with the shoes with mud and grease will cause a slip accident.
- Do not leave the parts or tools around the operator's seat.
- Do not leave any plastic bottles in the operator's compartment or attach any suction cups on the window glass. The plastic bottle or suction cup act as a lens and can cause fire.
- Do not use the mobile phone during traveling or working.
- Do not bring combustibles or explosives into the operator's compartment.
- After smoking, be sure to tightly close the lid of the ashtray to put out the match or cigarette.
- Do not leave the cigarette lighter in the operator's compartment. When the room temperature rises, the lighter may explode.

Emergency exit

Front window (excluding machines with a front guard)

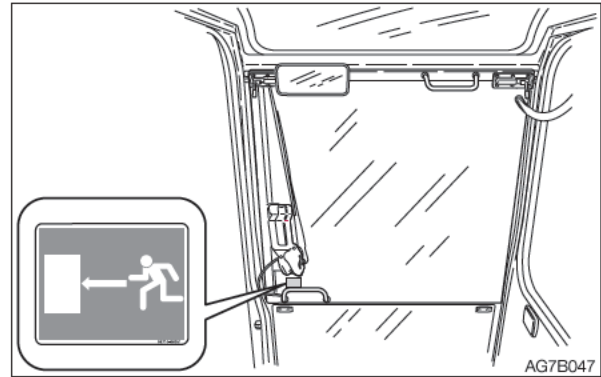

If you should become trapped inside the cab, open the front window to get out.

Emergency hammer (optional)

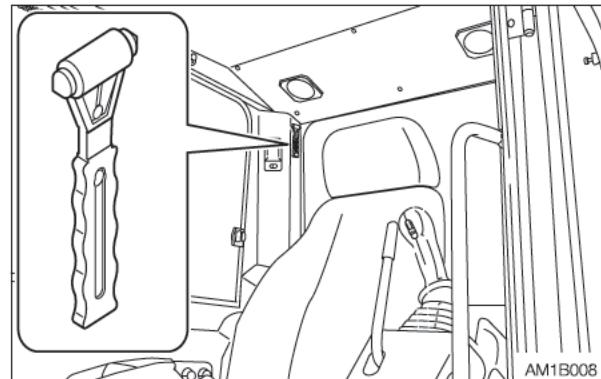

An emergency hammer is installed to be used to escape from the cab in an emergency. When escaping, break the windows with the hammer.



PRECAUTIONS WHEN STARTING

Support your weight in a three point secure stance when getting on/off the machine

- Do not jump on or down from the machine. Never attempt to get on or off the moving machine.
- When getting on or off the cab, first fully open the door to the locked position and check that it does not move (for machines with cab).



- Climb up/down the steps facing the machine and holding the handrail to support your weight in a three point secure stance (hand and feet).
- Never use the safety lock lever or control levers as hand holds.

Before starting the machine, ask any unauthorized personnel to leave the area

Do not start the engine until you are sure it is safe to start the machine by checking the following items.

- Walk around the machine and warn the person who is servicing the machine or is walking near the machine. Do not start the machine until you are certain that no one is around the machine.



- Check if there is a “DO NOT OPERATE” alert sign or similar sign is on the cab door, controls or starter switch. If there is one, do not start the engine or touch any levers.
- Sound the horn to warn people around the machine.

Sit in the operator’s seat and start the engine

- Adjust the seat to securely latch it.



- Fasten the seat belt.
- Check if the parking brake is on and all control levers and pedals are in the neutral position.
- Check if the safety lock lever is in the lock position.
- Make sure that no one is near the machine.
- Start and operate the machine only from the operator’s seat.
- Never attempt to start the engine by shorting across the starter terminals.



Starting with jumper cables

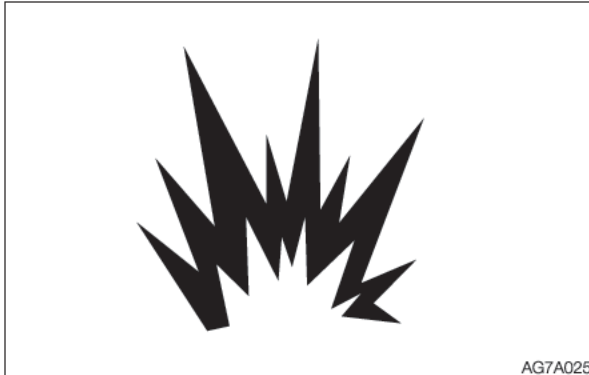

Use jumper cables only in the recommended manner. Improper use of jumper cables can result in battery explosion or unexpected machine motion.

Refer to “If the battery goes dead” for further instructions.

After starting the engine

After starting the engine, perform the operations and checks described below in a safe place with no persons or obstacles in the area. If any malfunction is found, follow the shutdown procedure and report the malfunction.

- Warm up the engine and hydraulic oil.
- Check if all gauges and warning devices are properly working.
- Check for any noises.
- Test the engine speed control.
- Operate each control to ensure they are properly working.

In cold climates



- Be careful of slippery conditions on freezing ground, steps and hand holds.
- In severe cold climates, do not touch any metal parts of the machine with bare hands. The skin will freeze to the metal, resulting in severe injury.
- Do not use ether or starting fluid on this engine. The starting fluids can cause explosion and serious injury or death.
- Warm up the engine and hydraulic oil. If the levers are operated without warming, the machine will not react or move promptly or properly, resulting in accident.



SAFETY PRECAUTIONS WHEN OPERATING

PRECAUTIONS WHEN OPERATING

Ensure good visibility

- When working in dark places, turn on the machine's working lights and headlights and additional lighting equipment installed, as necessary.
- When visibility is poor due to bad weather (fog, snow, rain or a cloud of dust), stop operating the machine and wait until visibility improves.

Do not permit riders on the machine



Do not allow anyone to ride on any part of the machine at any time while traveling or operating.

Check if the work area is safe and secure before operation

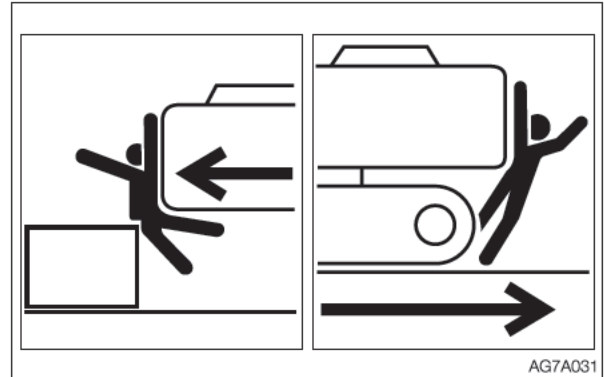

- Confirm the performance limits of the machine.
- Use a signal person at road shoulders, narrow places or where your vision is obstructed.
- Never allow anyone to enter the machine's slewing radius and path.
- Signal your intention to move by sounding the horn.
- There is a blind spot in the rear of the machine. Before traveling in reverse, check that the area is safe and clear.



SAFETY PRECAUTIONS WHEN OPERATING

Check the position of the undercarriage (tracks) before traveling

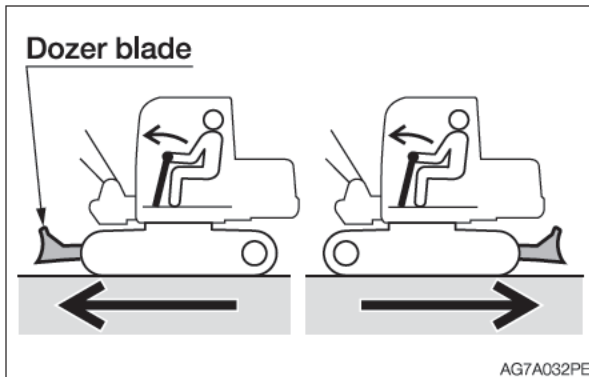

Before operating the travel levers/pedals, make sure that the dozer blade is to the front of the operator's seat. Remember that when the dozer blade is to the rear of the operator's seat, the travel levers/pedals must be operated in the reverse direction from when it is to the front.

Travel safely

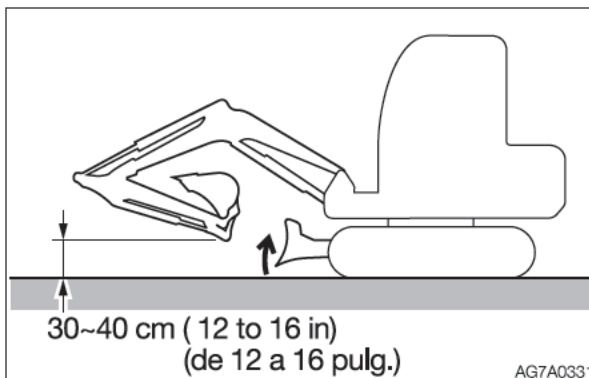

- Travel with the dozer blade raised, the hoe attachment folded as shown on the figure above, and the bucket raised 30 to 40 cm (12 to 16 in.) above the ground.
- Do not slew while traveling. If you must operate the hoe attachment while traveling, operate at speeds slow enough so you have complete control at all times.
- When a load greater than a set value is applied during traveling in 2nd (high) speed, the speed will automatically slow down to 1st (low) speed. When the load becomes lighter, the speed will increase and return to 2nd (high) speed. Remember

that the travel speed changes depending on the load condition (for machines with the automatic travel shift-down system).

- When traveling on the uneven road or sharp slope, turn off the deceleration switch and the auto-deceleration switch. If the machine is operated on such roads with these switches turned on, the engine speed may increase, causing the machine to travel unexpectedly rapidly (for machines with the deceleration and auto-deceleration switches).

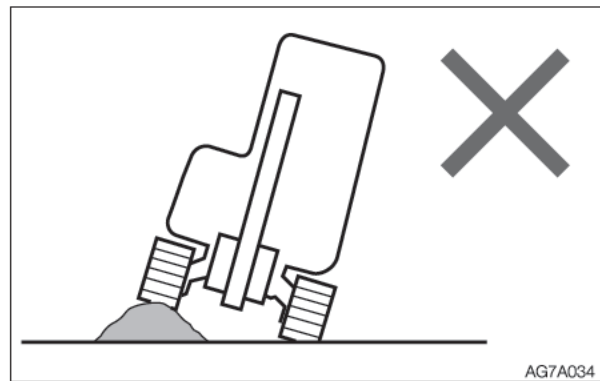

- Avoid crossing over obstacles whenever possible. If you must do so, keep the hoe attachment close to the ground level and travel slowly. Never cross obstacles which will tilt the machine to an angle of 10° or greater.
- On uneven ground, maintain the low speed and avoid starting, stopping or changing directions abruptly. Otherwise, the working equipment may come in contact with the ground, causing the machine to lose its balance and get damaged or to damage the structures in the surrounding area.



SAFETY

PRECAUTIONS WHEN OPERATING

Cautions on traveling on slopes

When traveling on slopes or grades, be careful that the machine does not tip (roll) over or slide.

- Never travel on slopes that are too steep for the machine to maintain its stability (maximum gradeability: 35°, lateral tipping angle: 15°). Note that in reality, the machine's stability becomes lower than the above values depending on the working condition.

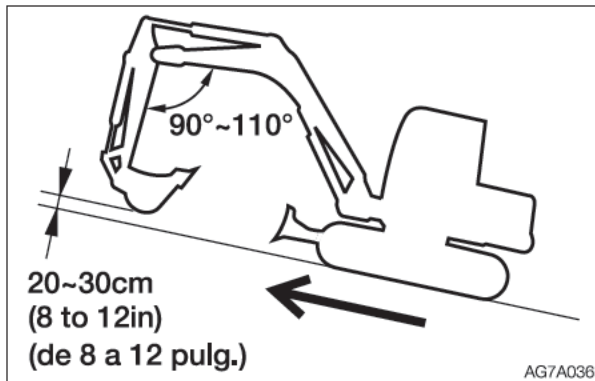
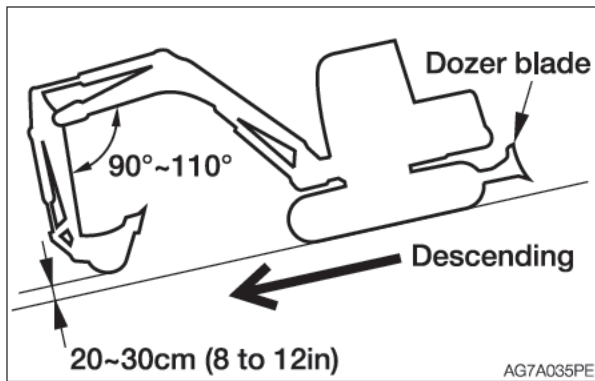

- When traveling on slopes or grades, drive slowly in 1st (low) speed. When descending a slope, slow down the engine speed.
- Do not descend slopes in reverse.

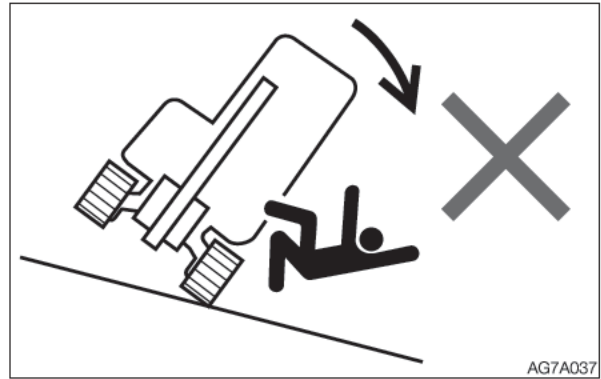

- Do not change directions on slopes or traverse slopes. First return to a flat surface, and then take an alternative path.
- The machine may slip sideways even on a slight slope if the ground is covered with grass or dead leaves, or when traveling on a wet metal plate or frozen surfaces. Make sure the machine is never positioned sideways on slopes.
- If the machine is stalled on the slope, return each operating lever to the neutral position before restarting the engine.

- When climbing a hill, keep the operator's seat facing the hillside. When descending a hill, keep the operator's seat facing the downhill direction. In either case, travel must be done while paying attention to the ground in front of the machine.
- When traveling on slopes, lower the bucket to a height of 20 to 30 cm (8 to 12 in.) above the ground. When climbing a steep slope, extend the hoe attachment to the front. In emergencies, lower the bucket to the ground and stop the machine.

**Operate the machine on snow or ice with extra care**

- When traveling on snow or on frozen surfaces, drive at a low speed and avoid starting, stopping or changing directions abruptly.
- In the snowy area, the road shoulder and objects placed beside the road are buried in the snow and cannot be seen. There is a hazard of the machine tipping over or hitting covered objects, so always carry out operations carefully.
- If the machine enters deep snow, there is a hazard that it may tip over or become buried in the snow. Be careful not to drive beyond the road shoulder or to get trapped in a snow drift.
- With frozen ground surfaces, the ground becomes soft when the temperature rises, and this may cause the machine to tip over, resulting in an operator trapped inside the machine.
- When parking the machine on an unstable ground, lower the dozer blade.

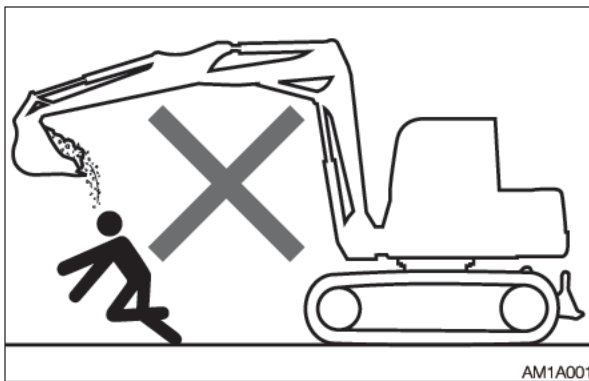
Do not move the bucket over the heads of people

Moving the bucket over the heads of people entails the danger of the load spilling or the sudden dropping of the bucket.

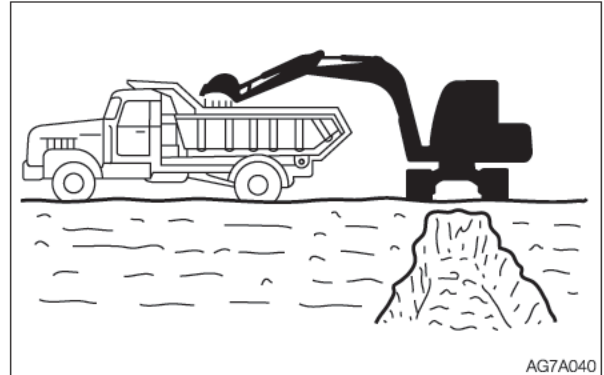
Ensure driver's safety when loading

Do not load a truck unless the truck driver is in a safe place.

- Never swing or position the bucket over a person or the cab room.
- Load the truck from the rear.



SAFETY PRECAUTIONS WHEN OPERATING

Keep a safe distance from the overhead high-voltage cables



Never bring any part of the machine or loaded material to near to the high voltage cables unless all safety precautions required by the local and national authorities have been installed. If a person comes near to the machine that is discharging sparks or located near to or in contact with the power source, there is a hazard of electric shock and death.

- Always maintain a safe distance between the machine and the high-voltage electric cable.
- Check with the local power company about safe operating procedure before starting operations.
- Consider all cables to be high-voltage cables and treat all cables as energized even though it is known or believed that the power is shut off and the cables are visibly grounded.
- Use a signal person to give warning if the machine approaches too close to the high-voltage electric cables.
- Caution all personnel in the work area not to come close to the machine or the loaded material.

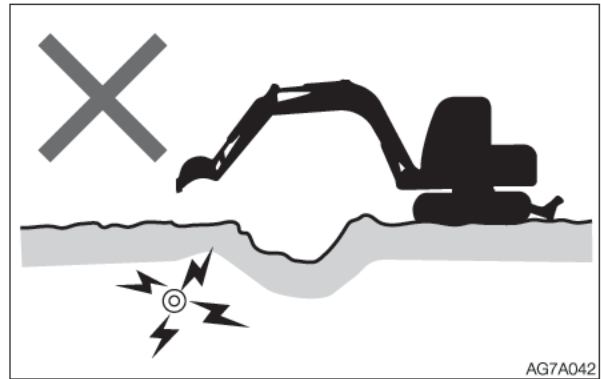

- Pay also careful attention to the high-voltage electric cables buried underground.



SAFETY PRECAUTIONS WHEN OPERATING

Watch out for hazardous working conditions

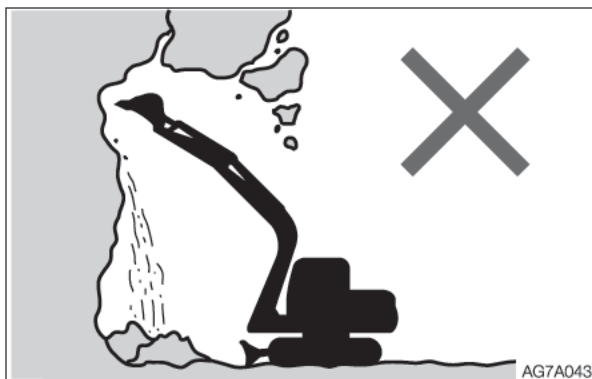

- Never undercut a high bank. Doing so is dangerous as it may cause ground collapse.
- Do not operate in places where there is a danger of falling rocks.

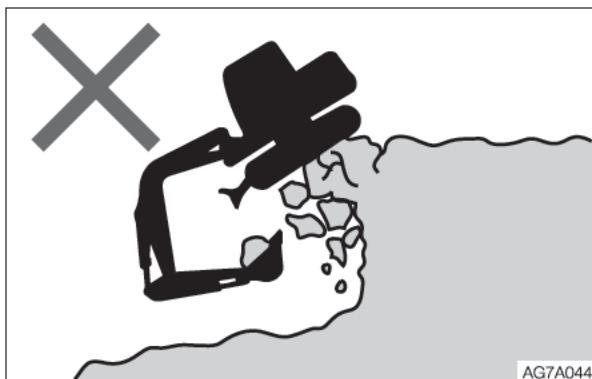

- Maintain a safe distance between the machine and the edge of the digging site. Do not dig the ground under the front of the machine.
- When working close to the cliffs or road shoulders, to make it easier to escape if there is any problem, set the crawlers at right angles to the cliff or road shoulder and the dozer blade to the front when carrying out operations.



- Do not enter areas where there is soft ground. Doing so could cause the machine to tilt under its own weight, resulting in a machine tipping over or sinking into the ground.

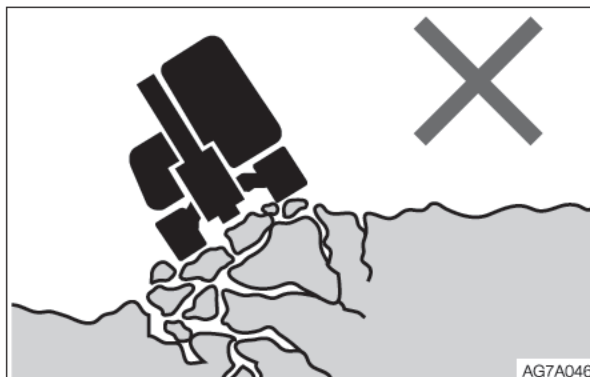

- Do not come close to unstable grounds (cliffs, road shoulders, deep ditches). If the ground should collapse under the weight or vibration of the machine, there is a hazard that the machine may fall or tip over.
 - Remember that the soil after heavy rain or blasting is weak.
 - The ground of top of the embankment and of the circumferences of the excavated ditches are also weak.



SAFETY

PRECAUTIONS WHEN OPERATING

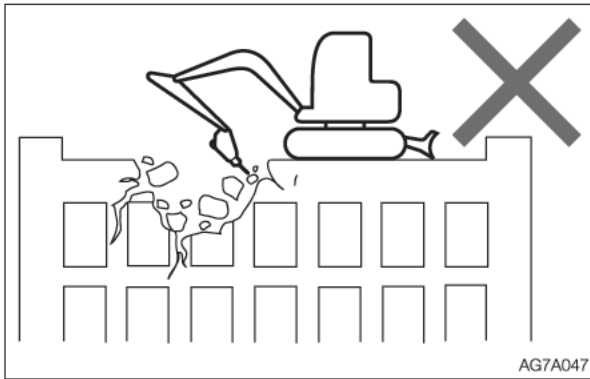

- Do not perform demolition work under the machine. There is a hazard that the machine may fall down, because the ground becomes unstable.
- When working on or from the top of buildings or other structures, check the strength and the structure before starting operations. If a building or structure collapses, serious injury or damage will result.

- Do not use the impact force of the hoe attachment for breaking work. There is a hazard of serious injury being caused by flying pieces of broken materials and by the damaged hoe attachment.

Be careful with flying objects

This machine is not equipped with protective equipment to protect the operator from flying objects. Do not use this machine in places where there are risks of the operator being hit by flying objects.

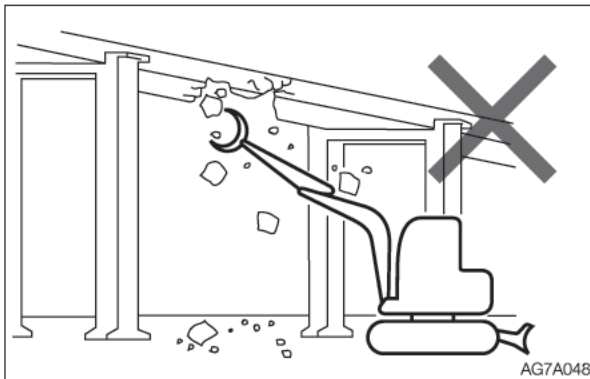

- When doing demolition work, do not perform demolition above your head. There is a hazard of broken parts falling or of the building collapsing and causing serious injury or damage.

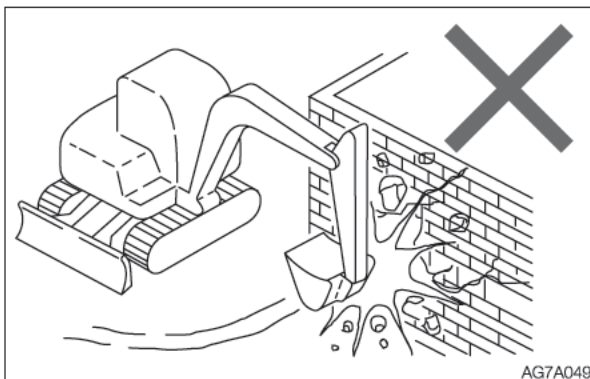



SAFETY PRECAUTIONS WHEN OPERATING

Operating on slopes is dangerous

When operating on slopes or grades, slewing or operation of working equipment may cause the machine to lose stability and tip over. Avoid operating on slopes whenever possible.

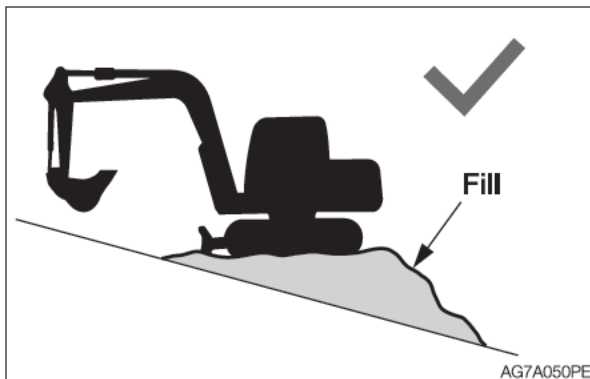

- Level off the work area.

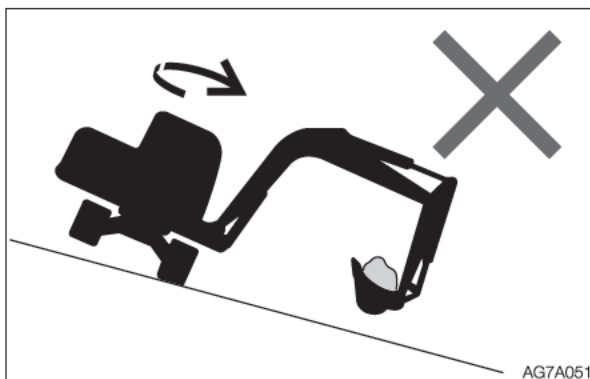

- Avoid slewing to the downhill direction with the bucket full of loaded material. This will reduce the stability of the machine and may result in tipping over.

Never slew (swing) sideways with a heavy load

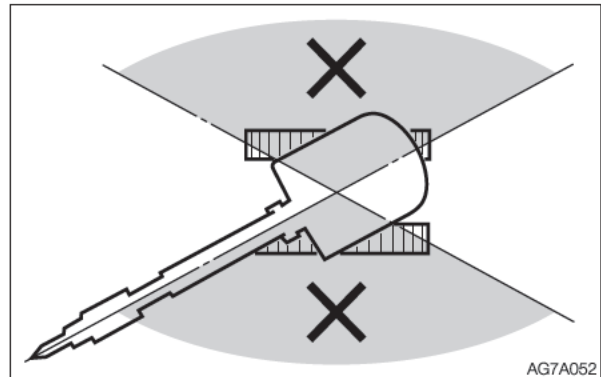

The machine can tip over more easily in the lateral direction than in the longitudinal direction.

- Do not slew (swing) sideways with a heavy load at the tip of the hoe attachment. In particular, do not slew (swing) sideways on slopes.
- The tip of the attachment is heavier for machines equipped with breakers, crushers or long arms than for machines equipped with the standard bucket. For such machines with heavier tips, do not perform excavation with the digging arm (boom) facing the downhill direction or operate toward sideways.

Be careful with the overhead objects

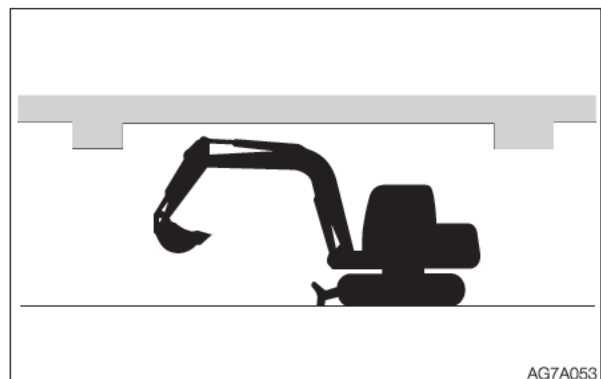

When operating under bridges, in tunnels, near electric cables or indoors, be careful not to let the boom or arm hit overhead objects.



SAFETY PRECAUTIONS WHEN OPERATING

Excavators are not designed for lifting loads



This machine is specifically designed for excavation work. Therefore, it has no safety equipment for crane operation. Extreme caution should be paid if the excavator is used for lifting.

- Never lift loads in excess of capacity. Overload will cause the machine to roll and can result in serious injury or death.
- All rated lift capacities are determined by using a machine placed on a stable and flat ground. For a safe lifting work, the user is expected to make due allowance for the particular job conditions. They include, soft or uneven ground, non-level condition, side loads, dynamic or jerked loads, hazardous conditions, and experience of personnel. The operator and other personnel should fully acquaint themselves with the operator's manual before operating this machine, and rules for safe operation of equipment shall be adhered to at all times.
- The bucket linkage or lifting device may fail if chains or lifting device are incorrectly attached, resulting in serious injury or death.
- Do not attempt to pull stumps out of the ground when using the machine as a crane. The loads imposed on the machine under this use are completely unknown.
- Do not allow anyone to stand on or under the lifted loads or come close to the work area.

Cautions when towing

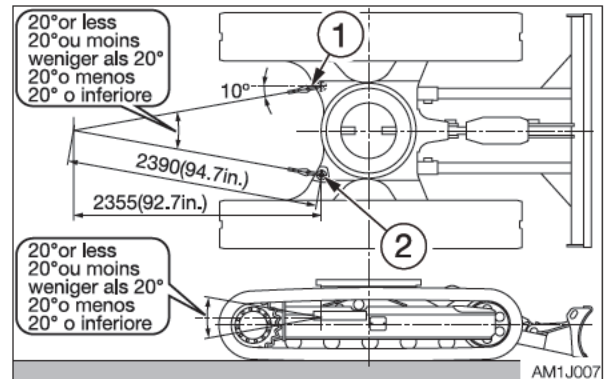

When towing, serious injury or death could result, if performed incorrectly or the wire rope being used is inappropriate or not properly inspected.

- It becomes dangerous if the wire rope breaks or becomes disengaged. Use a wire rope appropriate for the required tractive force.
- Do not use a wire rope that is kinked, twisted or otherwise damaged.
- Do not apply heavy loads abruptly to the wire rope.
- Wear safety gloves when handling the wire rope.
- Make sure there is an operator on the machine being towed as well as on the machine that is towing.
- Never tow on slopes.
- Do not let anyone come near to the wire rope while towing.



SAFETY PRECAUTIONS WHEN STOPPING

PRECAUTIONS WHEN STOPPING

Park safely

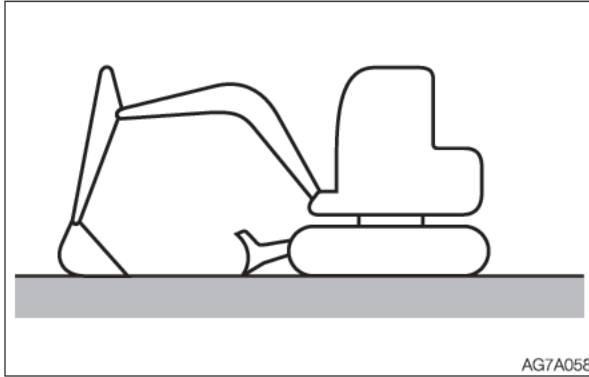

- Park the machine on a flat, rigid and safe ground. Set the parking brake.

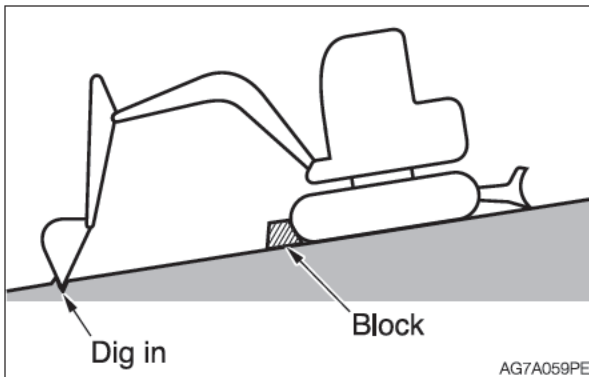

If you must park on a slope or incline, park the machine securely and block the movement of the machine.

- When parking on a street, use barriers, caution signs, lights, etc., so that the machine can easily be seen even at night to avoid collision with other vehicles.

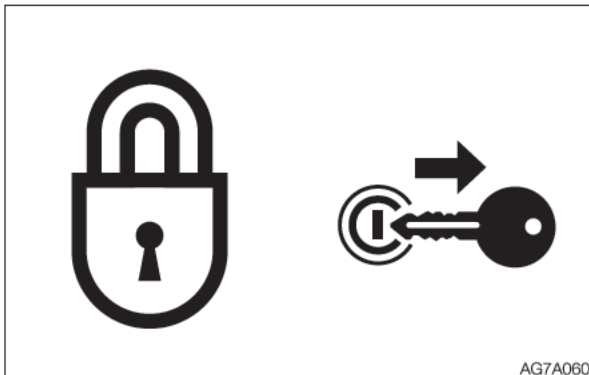

- Before leaving the machine, do the followings:
 1. Lower the bucket and the dozer blade to the ground.
 2. Raise the safety lock lever to the locked position.
 3. Stop the engine and remove the starter key.
 4. Lock the cab and covers and take the key with you.



PRECAUTIONS WHEN TRANSPORTING

Load/unload the machine safely

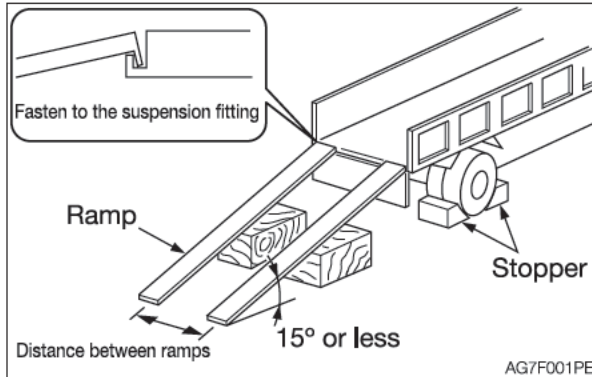

The machine may roll or tip over or fall while being loaded or unloaded. Take the following precautions:

- Select a firm, level surface and keep sufficient distance from road shoulders.
- Secure the ramps of adequate strength and size to the truck bed. The slope of the ramps must not exceed 15°. If the ramps are bowed down too low, support them with poles or blocks.
- Never use the working equipment to load or unload the machine. Doing so may result in tipping over or falling down of the machine.
- Keep the truck bed and loading ramps clean of oil, soil, ice, snow, and other materials to prevent the machine from sliding sideways. Clean the crawlers.
- Chock the transporter wheels to prevent movement.
- Turn off the deceleration switch and auto-deceleration switch. Otherwise, the engine speed may suddenly increase to cause troubles.
- When being loaded or unloaded, travel slowly in 1st (low) gear by following the signal from the signal person.
- Never change courses on the ramps.
- Do not slew/swing on the ramps. The machine may tip over.
- When slewing/swinging on the truck bed, do it slowly as the footing should be unstable.

- Lock the cab door after being loaded, if applicable. Otherwise, the door may open during transport.
- Chock the tracks and secure the machine to the truck bed with wire rope or chain.

**Hoist the machine safely**

- Know and use correct crane signals.
- Check the hoisting equipment for damaged or missing parts on a daily basis and replace as necessary.
- When hoisting, use a wire rope capable of lifting the machine mass.
- Hoist the machine in such a manner described in the procedure below. Do not do it in any other manner, as it may result in the machine losing its balance. Refer to “Hoisting the machine” for further instructions.
- Do not hoist the machine with an operator on it.
- When hoisting, hoist slowly so that the machine does not tip.
- Keep everyone out of the area when hoisting. Do not move the machine over the heads of the persons.

Transport the machine safely

- Know and follow the applicable safety rules, vehicle code and traffic laws when transporting the machine.
- Select the best transport route by considering the length, width, height and weight of the truck with the machine loaded on it.
- Never abruptly start or stop or run at a high speed at the sharp curves during transport. Doing so will move or lose the balance of the loaded machine.



PRECAUTIONS ON MAINTENANCE

Display a “DO NOT OPERATE” alert sign

Severe injury could result if an unauthorized person should start the engine or touch controls during inspection or maintenance.

- Before performing maintenance, stop the engine, remove the key and take it with you.



- Display a “DO NOT OPERATE” alert sign on easy-to-see locations such as on the starter switch or on control levers.

Use the correct tools

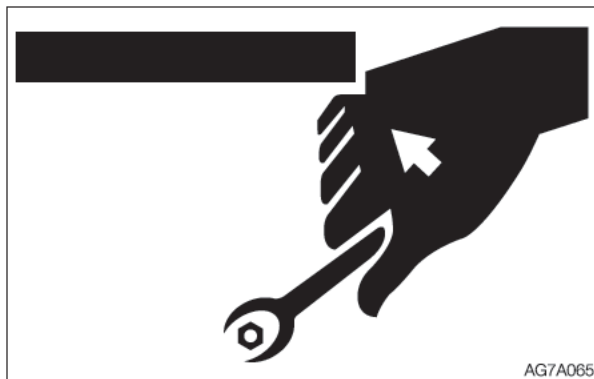

Do not use damaged or weakened tools or tools designed for other purposes. Use tools appropriate for the work involved.

Replace safety-critical parts periodically

- Replace fuel hoses periodically. Fuel hoses wear out over time, even if they do not show any symptom of wear.
- Regardless of the replacement schedule, replace immediately if a symptom of wear is found.
Refer to “List of safety-critical parts” for further details.

Explosionproof lighting



To prevent an ignition or explosion, use explosion-proof lights when inspecting fuel, oil, coolant or battery fluid. Otherwise, explosion could result causing serious injury or death.



SAFETY

PRECAUTIONS ON MAINTENANCE

Prohibit access by unauthorized persons

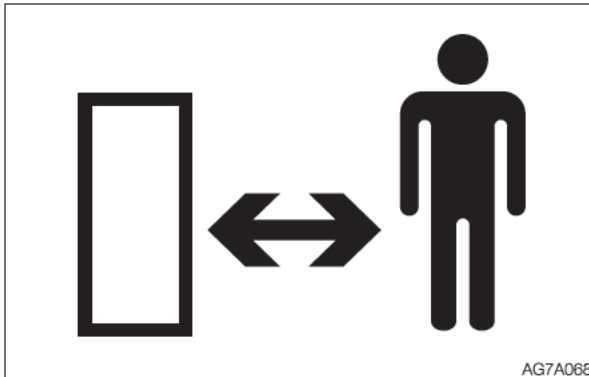

Do not allow unauthorized personnel in the work area while working. Be careful when grinding, welding or using a hammer. You could be injured by flying debris from the machine.

Prepare work area

- Select a firm, level work area. Make sure there is adequate light and, if indoors, ventilation.
- Clear obstacles and dangerous objects. Eliminate slippery areas.

Always keep the machine clean

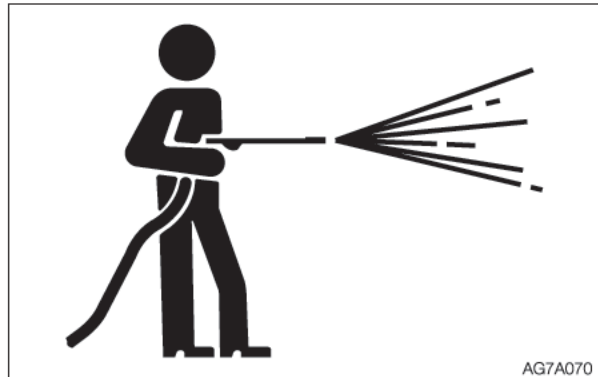

- Clean the machine before performing maintenance.
- Stop the engine before washing the machine. Cover the electrical parts so that water cannot enter. Water on electrical parts could cause short-circuits or malfunctions. Do not use water or steam to wash the battery, electronic control components, sensors, connectors or the operator's compartment.

Stop the engine before performing maintenance

- Avoid lubrication or mechanical adjustments while the machine is moving or while the engine is running when the machine is not moving.
- If maintenance must be performed with the engine running, always work as a two person team communicating each other.
 - One person must sit in the operator's seat so that he/she can immediately stop the engine when necessary. He/she must take care not to touch the lever or pedal unless necessary.
 - The one who performs maintenance must make sure to keep his/her body or clothing away from the moving part of the machine.



Stay clear of the moving parts

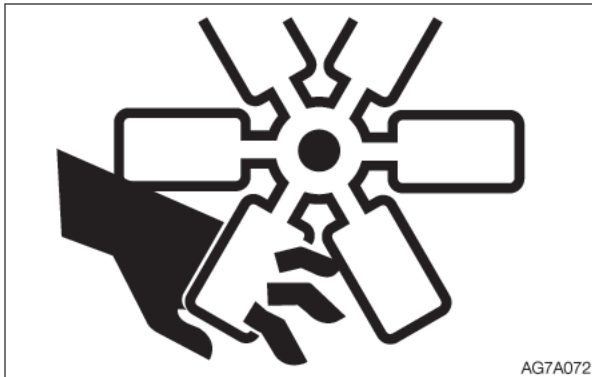

- Stay clear of all rotating and moving parts. If a hand or tool becomes trapped in the rotating or moving part, serious injury or death could result.
- If a tool or other objects is dropped or inserted in the fan or fan belt, it will be flown or cut in pieces. Do not drop or insert anything in the fan or fan belt.

Firmly secure the machine or any component that may fall



- Before performing maintenance or repairs under the machine, lower all moveable working equipment to the ground or in the lowermost position.
- Chock the tracks.
- If you must work beneath the raised machine or equipment, always use wood blocks, jack-stands or other rigid and stable supports. Never get under the machine or working equipment if they are not sufficiently supported. This procedure is especially important when working on hydraulic cylinders.

Secure the working equipment

To prevent unexpected movement, firmly secure the working equipment when repairing or replacing the bucket teeth or side cutter.

Secure the engine hood or cover when opened

Be sure to secure the engine hood or cover before working the inside. Do not keep the hood or cover open on a windy day or if the machine is parked on a slope.

Place heavy objects in a stable position



When it is necessary to temporarily place a heavy object or an attachment on the ground during removal or installation, be sure to place it in a stable position. Keep off unauthorized persons from the storage place for such object.



Cautions when refueling



- Do not smoke or permit open flames while fueling or near fueling operations.
- Never remove the fuel cap or add fuel when the engine is running or still hot. Do not spill fuel on the hot surface of the machine.
- Fill the fuel tank in a well ventilated place.
- Do not fill the fuel tank to capacity. Allow room for oil expansion.
- Clean up spilled fuel immediately.
- Securely tighten the fuel filler cap. If the fuel cap is lost, replace it only with the genuine cap. Use of a non-approved cap without proper venting may result in pressurization of the tank.
- Never use fuel for cleaning.
- Use the correct grade of fuel for the operating season.

Handling of hoses

Oil leak or fuel leak can cause a fire.

- Do not twist, bend or hit the hoses.
- Never use twisted, bent or cracked pipes, tubes or hoses; otherwise, they may burst.
- Retighten loose connection.

Be careful with hot and pressurized components



Stop the engine and allow the machine to cool down before performing maintenance.

- The engine, muffler, radiator, hydraulic lines, sliding parts and many other parts of the machine are hot immediately after the engine is stopped. Touching these parts will cause burns.
- The engine coolant, hydraulic oil and other oils are also hot and under high pressure. Be careful not to touch the hydraulic oil when loosening the cap or plug. Working on the machine under these conditions could result in burns or injuries due to the hot oil spurting out.



SAFETY PRECAUTIONS ON MAINTENANCE

Be careful with hot cooling systems



Do not remove the radiator cap or the drain plug when the cooling water is hot. Stop the engine and wait until the engine and the cooling water cool. Then, slowly loosen the radiator cap to release the internal pressure and remove it.

Be careful with oil internal pressure

Pressure is maintained in the hydraulic circuit long after the engine has been shut down.

- Completely relieve the internal pressure before performing maintenance work.

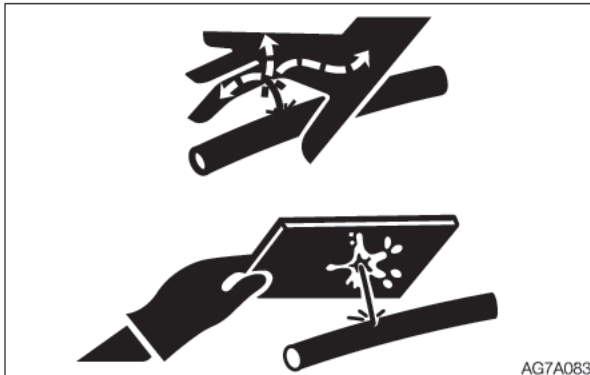

- The hydraulic oil is high enough pressure to penetrate the skin or eyes and cause serious injury, blindness or death. Remember that the hydraulic oil escaping from a small hole is almost invisible. When checking for leaks, wear protective goggle and thick gloves, and use a paperboard or plywood to keep your skin from oil spurting. If oil penetrates the skin, it must be surgically removed within a few hours by a doctor familiar with this type of injury.

Release pressure before working on the hydraulic system

Oil may spurt out if caps or filters are removed or pipes are disconnected before releasing the pressure in the hydraulic system.

- Immediately after the engine is stopped, and while the safety lock lever is still in the unlock position, turn the starter switch to ON and move all the control levers and pedals several times all the way in each direction to release the pressure from the working equipment circuitry.
- Press the air breather button to relieve the internal pressure from the tank.
- When removing plugs or screws, or when disconnecting hoses, stand to the side and loosen them slowly to gradually release the internal pressure before removing.
- Oil or plug may spurt out according to the pressure in the travel motor case. Loosen the plug slowly and release the internal pressure.

Be careful with debris when the hammer is being used

When using a hammer, pins may fly out or metal particles may be scattered. This may lead to serious injury.

- If hard metal parts such as pins, bucket teeth, side cutter or bearings are hit with a hammer, wear protective gear such as safety goggles and gloves.
- When hitting pins or bucket teeth, always check that there is no one in the surrounding area.



SAFETY PRECAUTIONS ON MAINTENANCE

Never disassemble the track adjuster

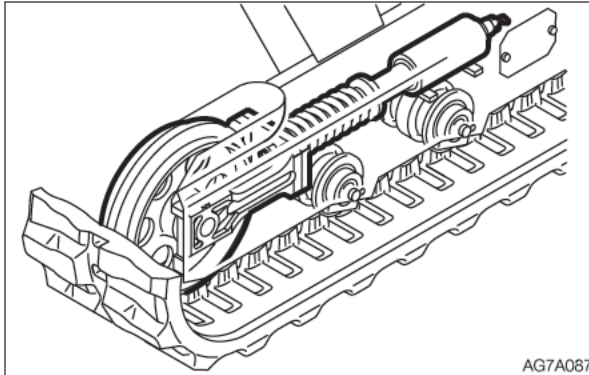

There is a very strong spring contained in the track adjuster. If the track adjuster is accidentally disassembled, the spring can pop out, resulting in serious injury. Never disassemble the track adjuster.

Cautions when servicing the air conditioner

If the refrigerant comes in contact with eyes, it damages your eyesight. If the refrigerant comes in contact with skin, it may cause frostbite. Never touch the refrigerant.

Handling of the accumulator



Be sure to handle the high-pressure nitrogen gas enclosed in the accumulator with care. If handled incorrectly, it could explode and cause serious injury. Strictly observe the following precautions:

- Do not disassemble.
- Do not allow flame near or throw it into a fire.
- Do not drill, weld or fuse.
- Do not subject it to physical shock such as hitting, rolling or dropping.
- Before disposing of the unit, the sealed gas must be drained. Contact a Takeuchi service agent for help.



Disconnect the battery wiring



Disconnect the battery wiring before working on the electrical system or doing electric welding. Disconnect the negative (-) battery cable first. When reconnecting, connect the negative (-) battery cable last.

Use caution when handling batteries

- Batteries contain sulfuric acid which will damage the eyes or skin in case of contact.
 - If eye contact occurs, flush immediately with clean water and get prompt medical attention.
 - If accidentally swallowed, drink large quantities of water or milk and call a physician immediately.
 - If acid contacts skin or clothing, wash off immediately with a lot of water.
 - Wear protective goggles and gloves when working with batteries.
 - Batteries generate flammable hydrogen gas which may explode. Keep away from flame, sparks, fire or lighted cigarettes.
 - When checking the level of the battery fluid, use a flashlight.
 - Be sure to stop the engine by turning off the starter switch before inspecting or handling the battery.
 - Be careful not to let metal tools or any metal objects come into contact with the battery terminals and cause a short circuit.
 - Loose battery terminals may result in sparks. Be sure to fasten terminals tightly.
 - Make sure the battery caps are tightened securely.
- Do not charge a battery or jump-start the engine if the battery is frozen; otherwise it may explode. Warm the frozen battery to 15°C (60°F) before use.
 - Do not use the battery when the fluid level is below the lower level limit. Doing so will hasten the deterioration of the internal portions of the battery and shorten the battery life. It also can cause rupturing (explosion).
 - Do not add the distilled water above the upper level limit. Doing so could cause the fluid to leak. This fluid can cause skin damage if contacted, or can cause the machine components to corrode.
 - Use a dampened cloth to clean around the fluid level line and check the fluid level. Do not clean with a dry cloth; otherwise it could cause static electricity to build up, resulting in ignition or explosion.



Periodically replace the safety-critical parts

- To use the machine safely for a longer period, periodically add oil and perform inspection and maintenance. To improve safety, replace the safety-critical parts like hoses and seat belts periodically. Refer to “Safety-critical parts to be replaced periodically” for further details.
- The “Safety-critical parts to be replaced periodically” are the parts which deteriorate, wear and fatigue after repeated use and whose properties change over time. While these characteristics of these parts could cause serious physical or personal damage, judging the remaining life of these parts is difficult from external inspection or the feeling when operating.
- Replace the “Safety-critical parts to be replaced periodically” if any defect is found from external inspection, even when they have not reached the time specified interval.

Jump starting with booster cables

- When starting the engine using the booster cables, be sure to connect the cables in the proper order described below. Wrongly connected cables can result in sparking and battery explosion.
 - Do not allow the “machine in trouble” and “rescue machine” to touch each other.
 - Do not allow the positive (+) and negative (-) clips of the booster cables to touch each other or to come in contact with the machine.
 - When connecting, attach the positive booster cable to the positive (+) terminals first. When disconnecting, remove the negative cable from the negative (-) terminal (ground) first.
 - Be sure to connect the clips securely.
 - Connect the last clip of the booster cable to a point as far away from the battery as possible.
- Always wear the protective goggles and gloves when starting the engine by using the booster cables.
- Use the booster cables and clips of a size suited to the capacity of the battery. Do not use damaged or corroded booster cables and clips.
- Be sure that the battery of the “rescue machine” has the same capacity as the battery of the “machine in trouble”.



Have a Takeuchi service agent repair welding

If welding must be performed, make sure that it is done by a qualified person in a properly equipped workplace. To prevent any part from breaking down or being damaged due to overcurrent or sparks, observe the following.

- Disconnect the wiring from the battery before doing electric welding.
- Do not continuously apply 200 V or more.
- The earth ground must be connected within one meter from the welding section. Do not connect the earth ground near to an electronically controlled device/instrument or connectors.
- Make sure that there are no seals or bearings between the welding section and the earth ground.
- Do not connect the earth ground around the pins for the working equipment or hydraulic cylinders.
- When welding is to be done on the machine body, disconnect the connectors for the electronically controlled devices before working.

Vibrations operators are subject to

According to the results of the tests conducted to determine the vibrations transmitted to the operator by the machine, the upper limbs are subjected to vibrations lower than 2.5 m/s^2 (8.2 ft/s^2) while the seated part of the body is subjected to vibrations lower than 0.5 m/s^2 (1.64 ft/s^2).

Checks after maintenance

- Gradually increase the engine speed from a low idle to maximum speed and check that there is no oil or water leaking from the serviced parts.
- Operate each control lever and check that the machine is operating properly.

Disposing of wastes

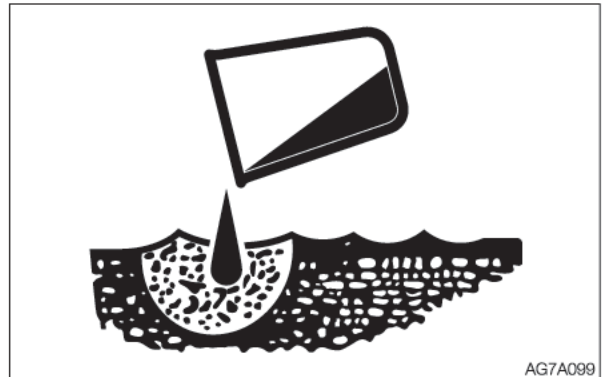

- Always collect oil that is drained from the machine in containers. Improperly disposed waste oil can cause environmental harm.
- Follow appropriate laws and regulations when disposing of harmful objects such as oil, fuel, coolant, solvent, filters and batteries.

Handling of poisonous chemicals

Poisonous chemicals will cause serious injury if directly contacted.

Poisonous chemistry used in this machine includes grease, battery solution, coolant, paint and adhesive agent.

Handle the poisonous chemicals properly with care.



SAFETY

SAFETY SIGNS (DECALS)

SAFETY SIGNS (DECALS)

For the safety of the operator and the personnel working around the site, safety signs (decals) are placed at certain locations on the machine as shown below. Walk around the machine with this manual, and check the content and location of these safety signs. Review these signs and the operating instructions in this manual with your machine operators.

- Keep the signs clean and legible. If any of the safety labels is peeling or damaged and becomes difficult to read, replenish it with a new one. Please include your product serial number when ordering a new sign from the Takeuchi service agent.
- When a part/unit to which a safety sign is attached is replenished, a new sign must be attached to the new part/unit.



SAFETY
SAFETY SIGNS (DECALS)

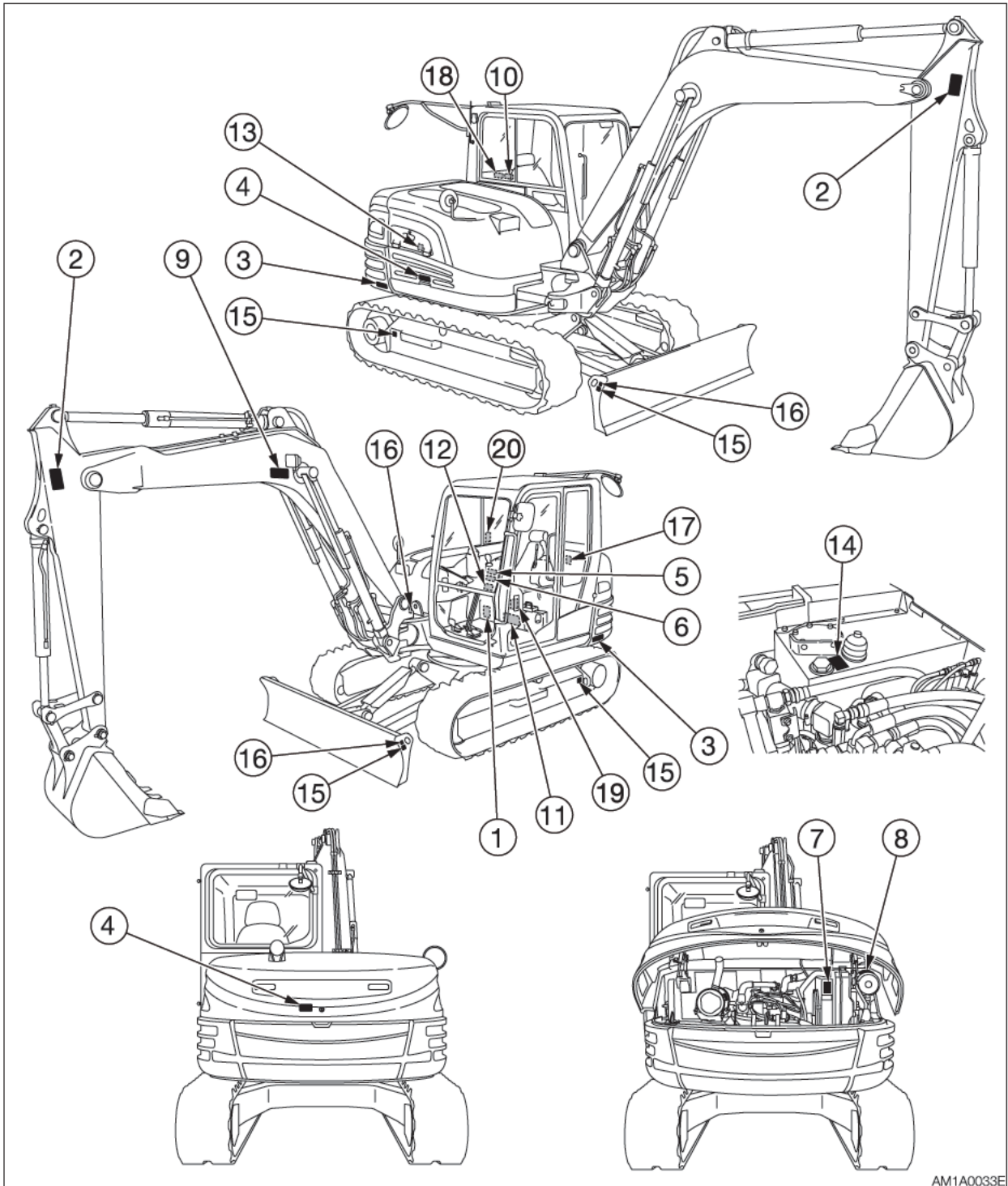

AM1A0033E



SAFETY
SAFETY SIGNS (DECALS)

1. No.0881031556

Warning
Read and understand this manual before performing any operation, inspection or maintenance on this machine.

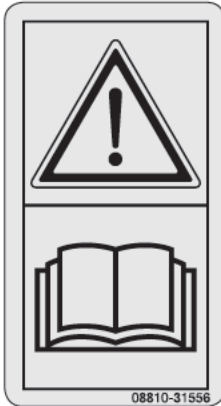

4. No.0379366006

Hazard of rotating parts
Turn off before inspection and maintenance.



5. No.0881031557

Hazard from falling window
After raising window, be sure to lock it in place with lock pins.



2. No.0579300049

Safety Distance
Hazard of being hit by the working device of the machine.
Keep away from machine during operation.



6. No.0579300045

Hazard at lifting or lowering window
When the front window is opened or closed, it will come close to the head. Be careful that the window does not strike the head.

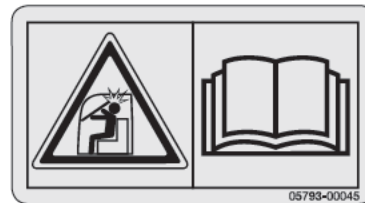

3. No.0579300011

Safety Distance
Do not get near or stand within the machine working area.



7. No.0579303630

Sign indicates a burn hazard from touching heated parts, such as engine, pump, or muffler during or right after operation.
Never touch when hot.



AM1A0041E



SAFETY
SAFETY SIGNS (DECALS)

8. No.0339375040



12. No.0871086051

Position of Emergency Exit

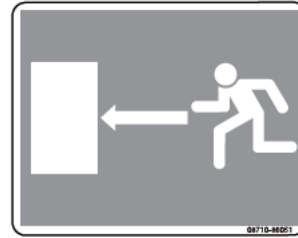

9. No.0359347010



13. No.0359306600

Diesel fuel



10. No.0359347020

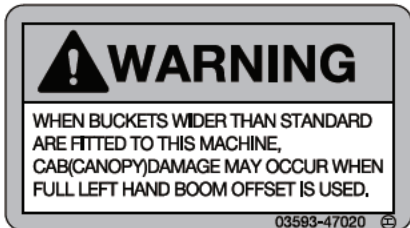

14. No.0359306700

Hydraulic oil



11. No.0359313700

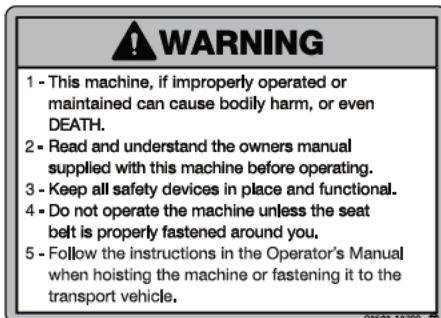



SAFETY
SAFETY SIGNS (DECALS)

15. No.0881031549
Tie down point



17. No.0399300400
For EU
Position of Fire extinguisher



16. No.0399300500
Position of hoisting



18. No.0359332300 (Option)



19. No.0399354628

Noise Outside the Cab / for EU

This value indicates the noise level outside the machine and refers to the noise perceived by the persons who are in the vicinity of the work area.



20. No.0379369110 (Option)



WARNING!

Do not press the float switch while the machine is raised by the dozer blade. Doing so may cause the machine to fall.

CONTROLS



NAMES OF COMPONENTS

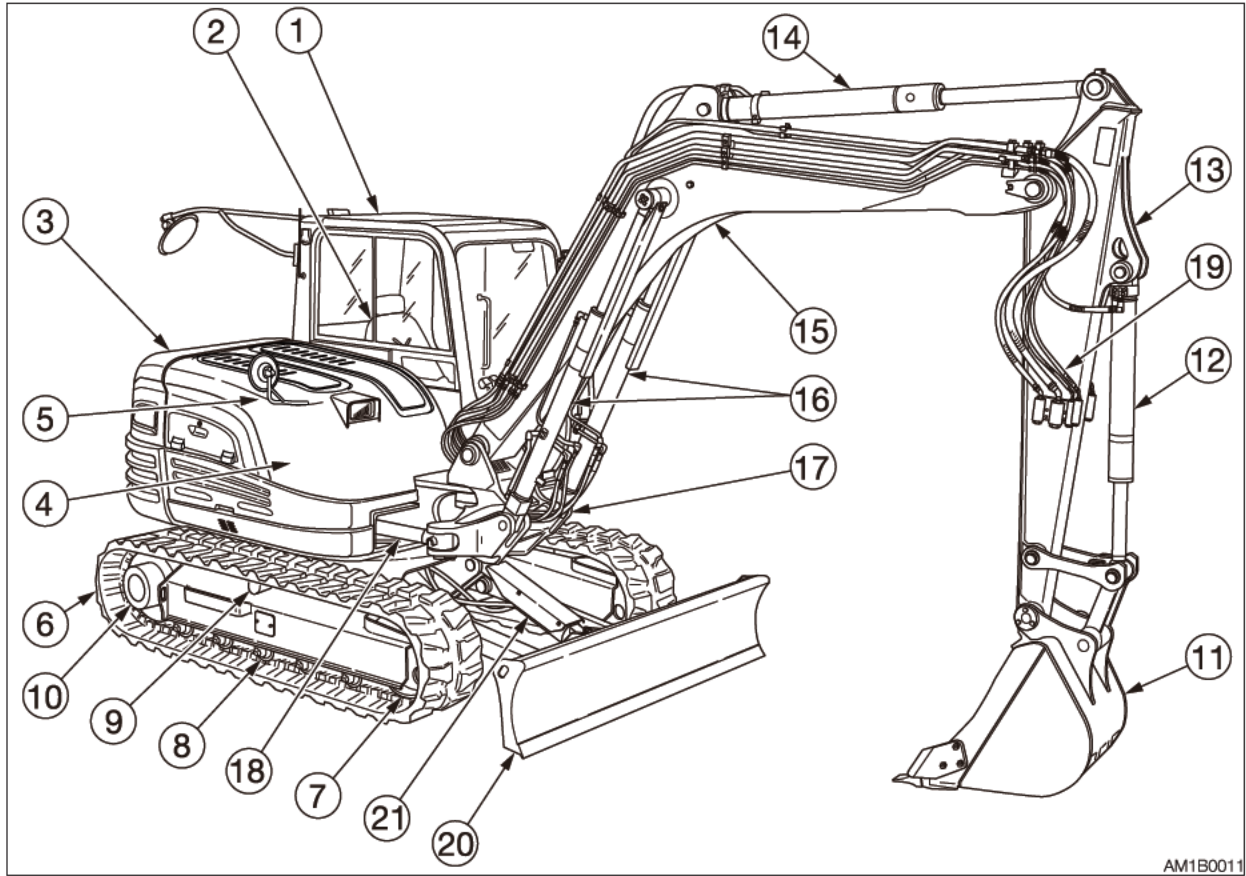

AM1B0011

Upperstructure

1. Cab
2. Seat
3. Engine hood
4. Fuel tank
5. Hydraulic tank

Undercarriage

6. Crawler belt
7. Idler
8. Track roller
9. Carrier roller
10. Travel motor

Working equipment

11. Bucket
12. Bucket cylinder
13. Arm
14. Arm cylinder
15. Boom
16. Boom cylinder
17. Boom bracket
18. Swing cylinder
19. Auxiliary hydraulic lines
20. Dozer blade
21. Blade cylinder
22. Second boom
23. Second boom cylinder

2-Piece boom

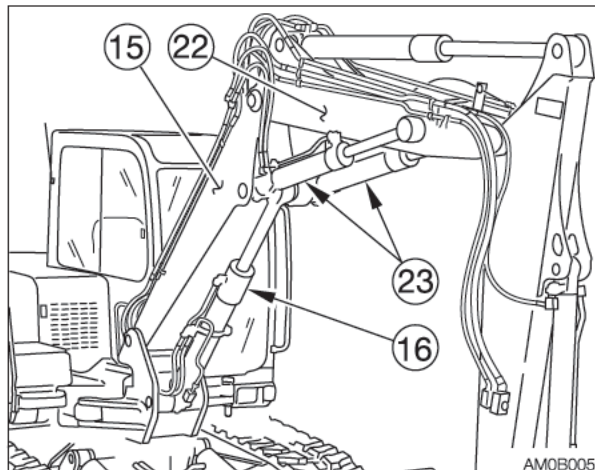

AM0B005



CONTROLS NAMES OF COMPONENTS

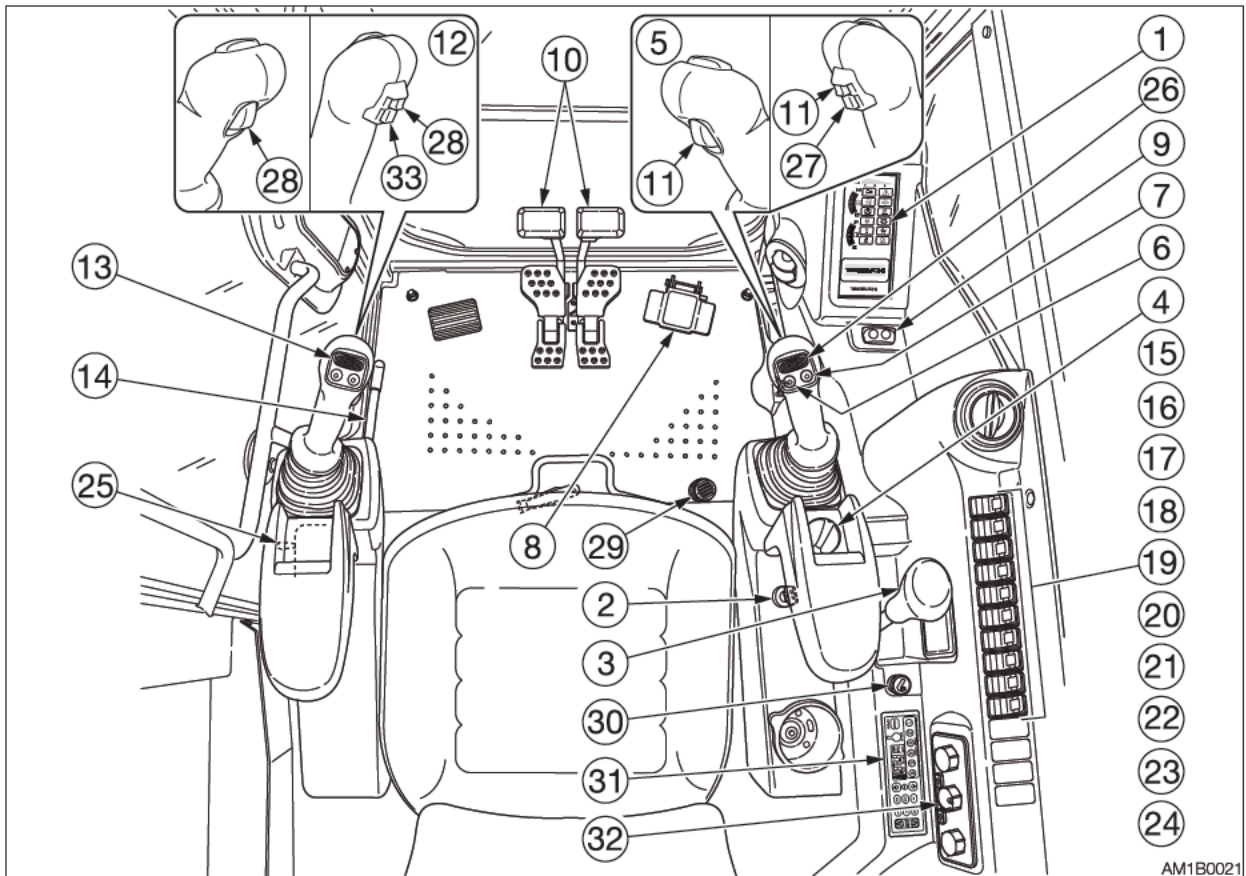

AM1B0021

- | | |
|---------------------------|---|
| 1. Instrument cluster | 18. Automatic deceleration switch* |
| 2. Starter switch | 19. ECO mode switch* |
| 3. Blade lever | 20. Highland mode switch* |
| 4. Throttle controller | 21. Auxiliary 1st flow rate select switch |
| 5. Right operating lever* | 22. Detent mode switch |
| 6. Horn button | 23. Overload warning switch* |
| 7. Deceleration button | 24. Beacon lamp switch* |
| 8. Boom swing pedal | 25. Engine shutdown switch |
| 9. Trip/Data switch | 26. Auxiliary 2nd/4th switch* |
| 10. Travel lever/Pedal | 27. Auxiliary 2/4 select button* |
| 11. Travel speed button | 28. Third auxiliary hydraulic button* |
| 12. Left operating lever* | 29. Third auxiliary hydraulic switch* |
| 13. Auxiliary 1st switch* | 30. Cigarette lighter |
| 14. Safety lock lever | 31. Radio |
| 15. Light switch | 32. AC Control panel* |
| 16. Wiper switch | 33. Swing/ Second boom select button* |
| 17. Washer switch | |

*: Subject to the specifications or optional products selected



COVERS

STARTER KEY



The starter key is used to start and stop the engine, as well as to lock and unlock the following components:

- Cab door
- Engine hood
- Covers

SIDE COVER

WARNING

- Stop the engine and allow the machine to cool down before performing maintenance.
- Be sure to secure the side cover with the stopper before working inside. Do not keep the side cover open on a windy day or if the machine is parked on a slope.
- When opening and closing the side cover, be careful not to get your hands or other parts of your body caught by the cover.

For inspection and maintenance of the hydraulic oil system, fuel system, coolant system or window washer, open this cover. The grease gun and the tools are also stored in the cover.

Opening

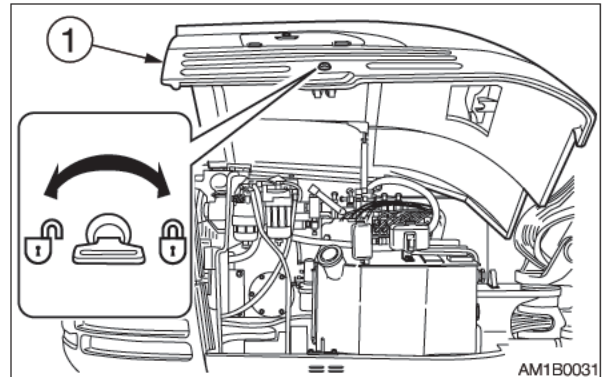

1. Insert the starter key and turn it counterclockwise to unlock the side cover (1).
2. Push in the key hole with your thumb and open the side cover (1) all the way.

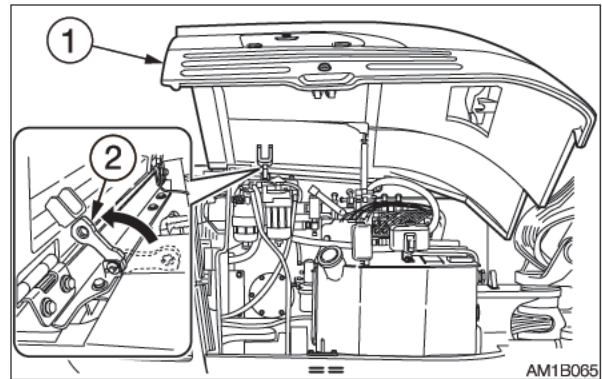

3. Raise the stopper (2) to secure the cover.
4. Store the tools.

Closing

1. Close the side cover (1) and press it down until a click is heard.



FUEL LID

CAUTION

When opening and closing the fuel lid, be careful not to get your hands caught by the lid.

For adding fuel or checking the level of hydraulic oil or coolant, open this cover.

Opening

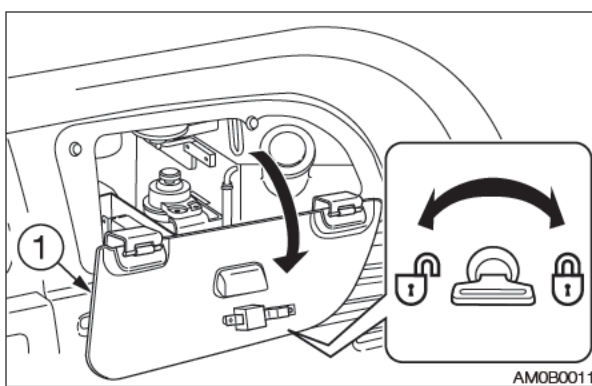

1. Insert the starter key and turn it counterclockwise to unlock the fuel lid (1).
2. Remove the starter key, push in the key hole with your thumb and open the fuel lid (1) all the way until it stops.

Closing

1. Close the fuel lid (1).
2. Insert the starter key and turn it clockwise to lock the fuel lid (1).

FUEL FILLER PORT

WARNING

- Do not smoke and keep away from heat or flame while filling the fuel tank.
- Fill the fuel tank in a well ventilated place, with the engine turned off.
- Clean up spilled fuel immediately.
- Do not fill the fuel tank to capacity. Allow room for oil expansion.
- Securely tighten the fuel filler cap.

Opening

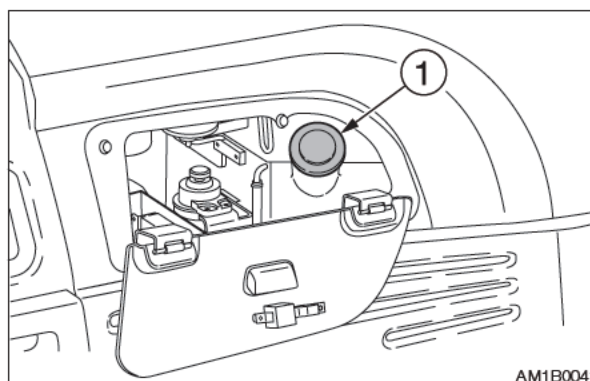

1. Open the fuel lid.
2. Turn the fuel cap (1) counterclockwise and remove it.

Closing

1. Turn the fuel cap (1) clockwise and close it.
2. Close the fuel lid and lock it.



ENGINE HOOD

WARNING

- Before opening the engine hood, be sure to stop the engine. If a hand or tool becomes trapped in the rotating or moving part, serious injury could result.
- Be sure to secure the side cover with the stopper before working inside. Do not keep the side cover open on a windy day or if the machine is parked on a slope.
- When opening or closing the engine hood, be careful not to get your hands or other parts of your body caught by it.

Opening

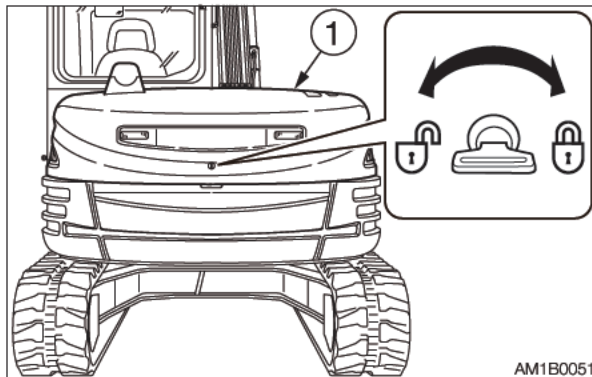

1. Insert the starter key and turn it counterclockwise to unlock the engine hood (1).
2. Push in the key hole with your thumb and open the engine hood (1).

Closing

1. Close the engine hood (1) and press down the edge of it until a click is heard.

FUSE BOX COVER

For inspection and maintenance of the fuse or air conditioner filter, open this cover. The port for connecting to a computer is inside the box.

Opening

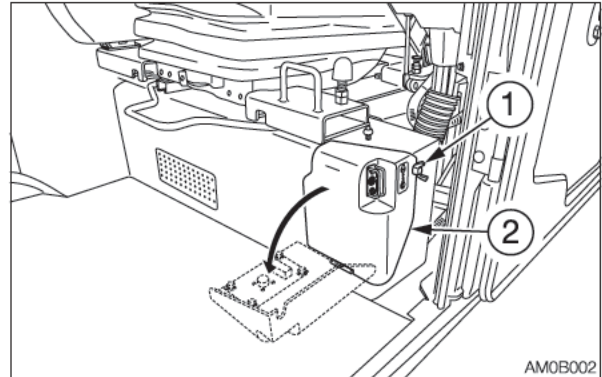

1. Remove the wing bolt (1).
2. Tilt the fuse box cover (2) forward.

Closing

1. Close the fuse box cover (2) and secure it with the wing bolt (1).



CAB

CAB DOOR

WARNING

When getting on or off the cab, first open the door all the way until it is secured in the catch and check that it does not move.

Open the door fully and press it against the catch at the back of the door to secure it in place.

The door must be locked when getting on or off the machine and while in operation.

Locking and unlocking

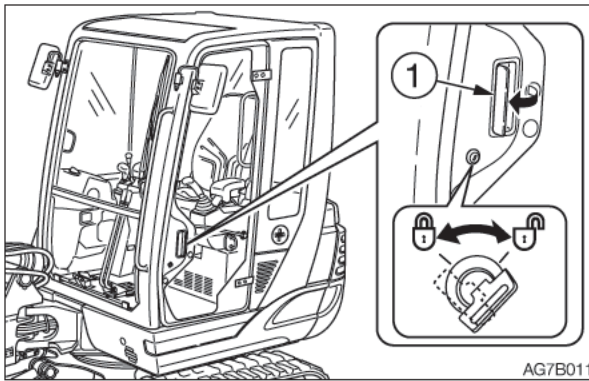

Insert the starter key and turn it.

Opening

1. Pull the knob (1) towards you and open the door.

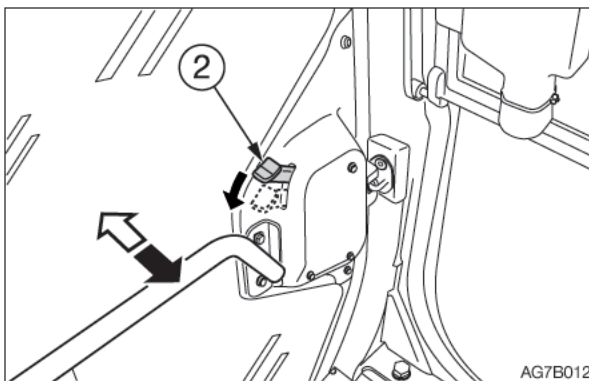

To open the door from inside the cab, push the lever (2) to the lower.

2. Open the door fully and press it against the cab to secure it in place.

Closing

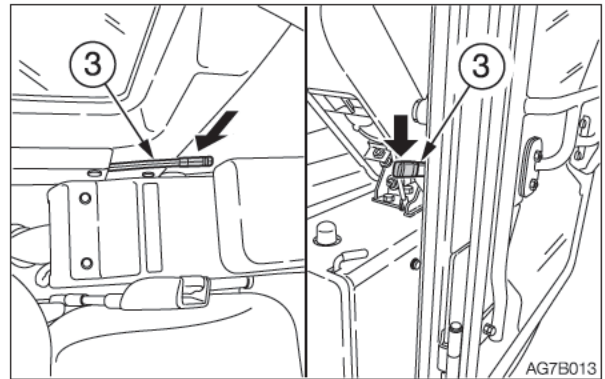

1. Push the release lever (3) to the lower.
2. Close the released door.

EMERGENCY EXIT

Front window (excluding machines with a front guard)

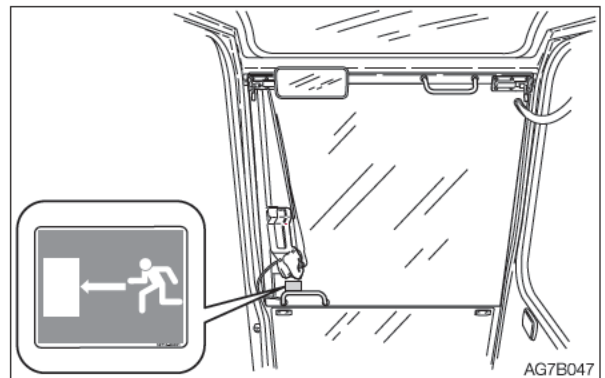

If you should become trapped inside the cab, open the front window to get out.



FRONT WINDOW

WARNING

- Grasp the handles firmly with both hands when opening and closing the front window. Your head or hands may get caught if it slips from your hands.
- When the front window is opened or closed, it will come close to the head. Be careful that the window does not strike the head.
- When you open the front window, be sure to lock it in place with the lock pins on the left and right sides. The window may fall if it is not locked in place.

Opening

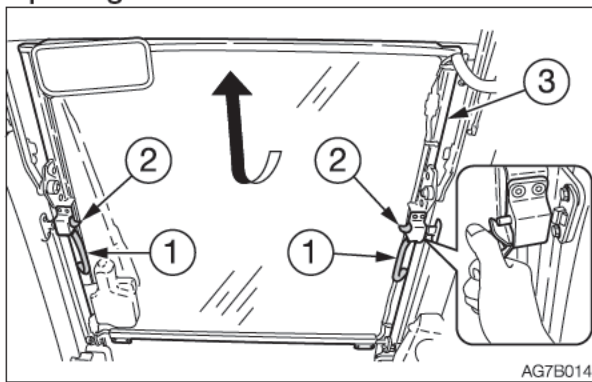

1. Park on a level surface and stop the engine.
2. Set the safety lock lever to the locked position.
3. Grasp the left and right handles (1) and press the knobs (2) with your thumb to release the lock.
4. Pull the front window (3) toward you and lift while doing so.

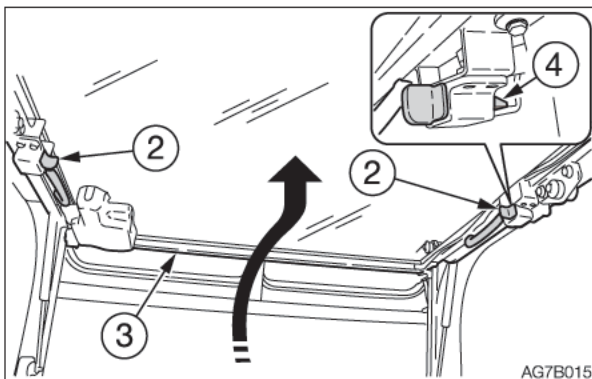

5. Release your thumb from the knobs (2) and then lift the front window (3) fully and lock the front window with lock pin (4).

Closing

WARNING

When closing the front window slowly so as not to hit your head. Lowering the window abruptly may result injury or damage the front window.

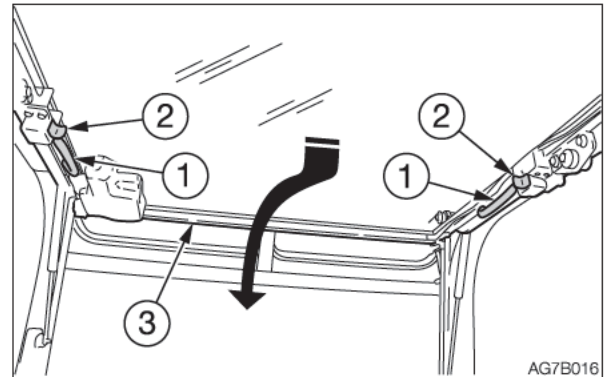

1. Grasp the left and right handles (1) and press the knobs (2) with your thumb to release the lock.
2. Pull down the front window (3) and while doing so, slide it to the front and slowly lower it.

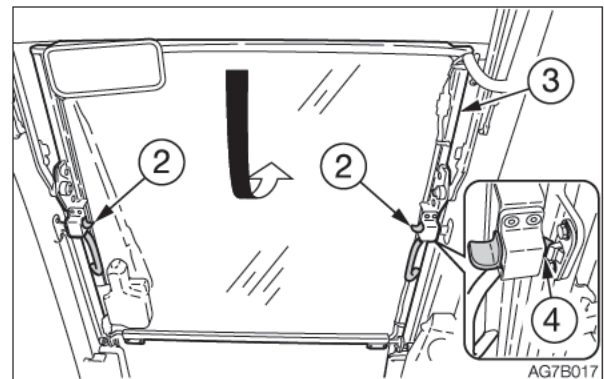

3. Release your thumb from the knobs (2) and then press the front window toward front and lock the front window with lock pin (4).



LOWER FRONT WINDOW

Removing

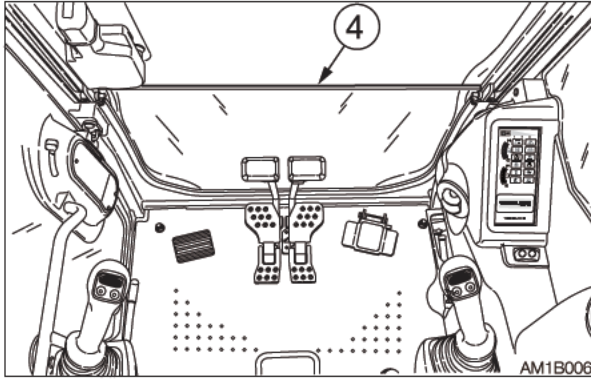

1. Open the front window and stow it in the ceiling.
2. Slowly lift the lower front window (4).

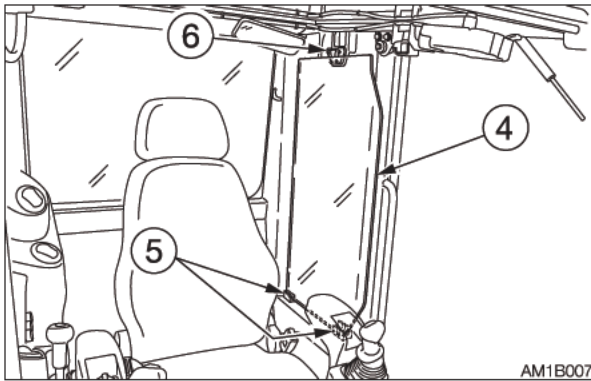

3. Hold the window in a vertical position (the bottom of the window should be in front of you), place it through the guide (5) on the left side of the cab, and then secure it with the support (6).

SIDE WINDOW

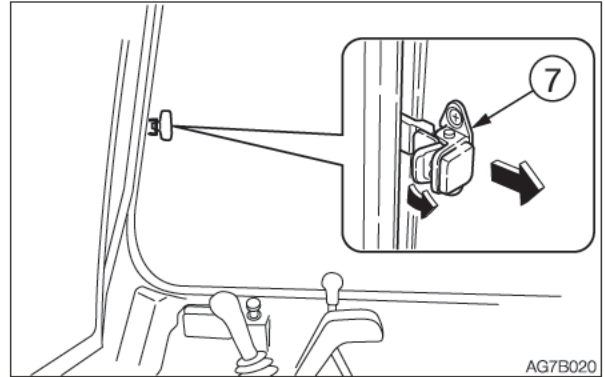

1. Grasp the catch (7), unlock it and open the side window.
2. To close the side window, close it until a click is heard.

EMERGENCY HAMMER (OPTIONAL)

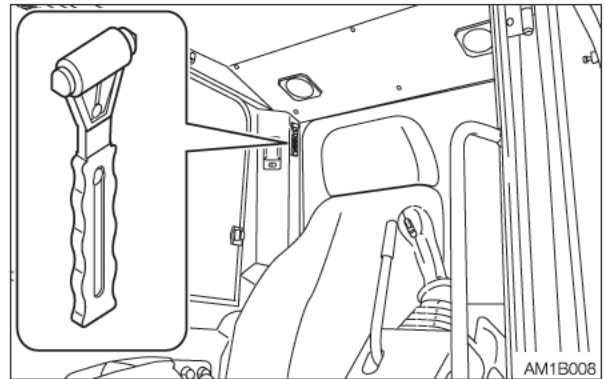

An emergency hammer is installed to be used to escape from the cab in an emergency. When escaping, break the windows with the hammer.



SEAT AND SEAT BELT

SEAT

WARNING

- Adjust and secure the seat.
- Do not make any adjustments while operating the machine.

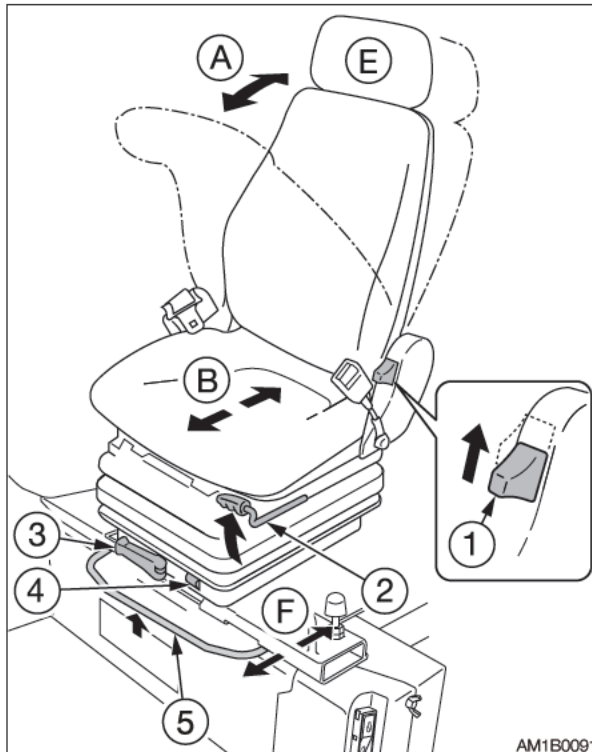

(A) Adjusting the backrest angle

WARNING

- Do not set the backrest to its maximum reclining position and slide the seat backwards at the same time. Doing so may damage the rear window or cause injury.
- Remember that the backrest returns to the forward position abruptly due to the spring force.

1. Sit up and sit back in the chair.
2. Pull up the lever (1), recline the backrest by using the spring force. Release the lever (1) at the desired angle to secure the backrest.

(B) Fore-and-aft adjustment

1. Pull up the lever (2) and slide the seat backward or forward to the desired position for operation of machine.
 2. Release the lever (2) at the desired position to secure the seat.
- Adjustment range: 15 positions, in 150 mm (5.9 in.)

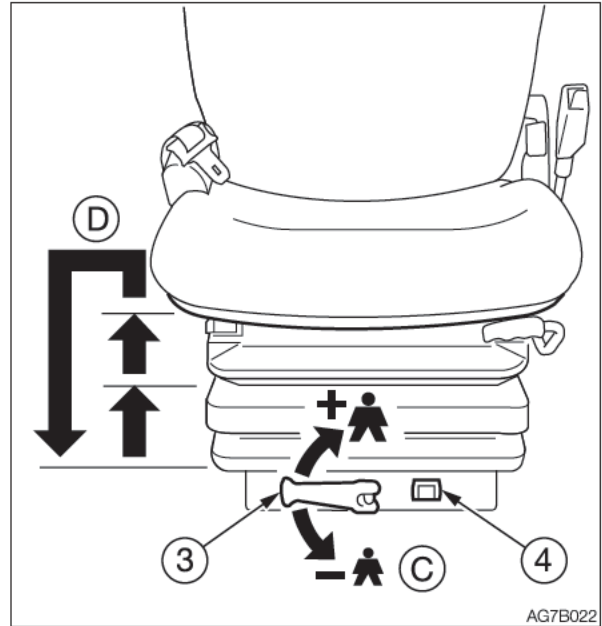

(C) Adjusting according to operator's weight

1. Turn the handle (3) until the scale indicates the weight of operator.
- Adjustment range: 50 to 130 kg (110 to 287 lbs)

(D) Adjusting the height of the seat

Upward

1. Lift the seat to first or second position click-stop.
- Adjustment ranges: 2 positions, in 60mm (2.36 in.)

Downward

1. First lift the seat to highest position, then the seat can be lowered to lowest position.



CONTROLS SEAT AND SEAT BELT

(E) Adjusting the headrest (Option)

The headrest (E) can be moved upward or downward.

1. Grab the headrest (E) with both hands, and move upward or downward to the desired position.

(F) Adjusting the operating lever stand

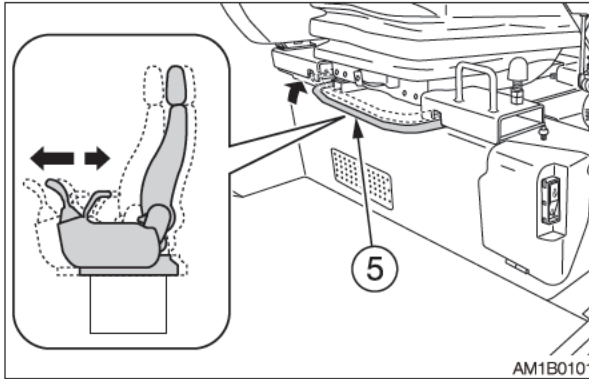

1. Pull up the lever (5) and slide the lever stand (seat).
2. Release the lever (5) at the desired angle to secure the lever stand (seat).
Adjustment range: 9 positions, in 90 mm (3.5 in.)

SEAT BELT

CAUTION

Be sure to fasten the seat belt securely before starting the engine.

Fastening the seat belt

1. Adjust the seat to the desired position for operation, sit up and sit back in the chair.
2. Pull the seat belt to the desired length.

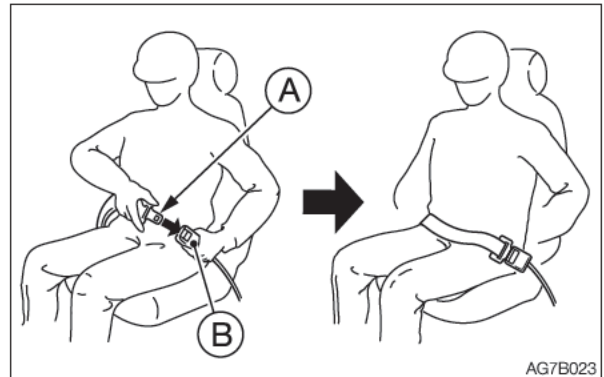

3. Make sure that the belt is not twisted and then insert the tongue plate (A) into the buckle (B) of the seat belt until you hear a clicking sound as it locks in place.
4. Check if the belt is securely locked by pulling it, and arrange the belt around your waist.

Releasing the seat belt

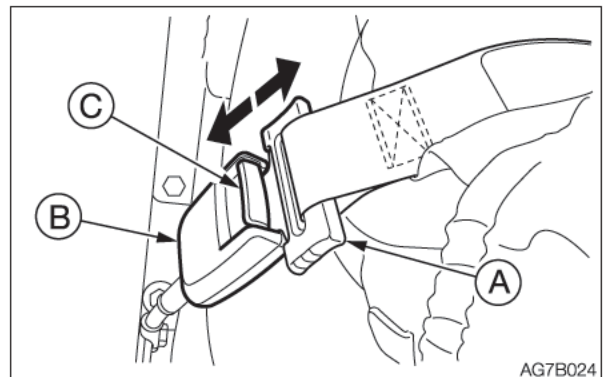

1. Grasp the tongue plate (A) and press the button (C) on the buckle (B).
The seat belt retracts back into its original position.



AIR SUSPENSION SEAT

WARNING

- Adjust and secure the seat.
- Do not make any adjustments while operating the machine.

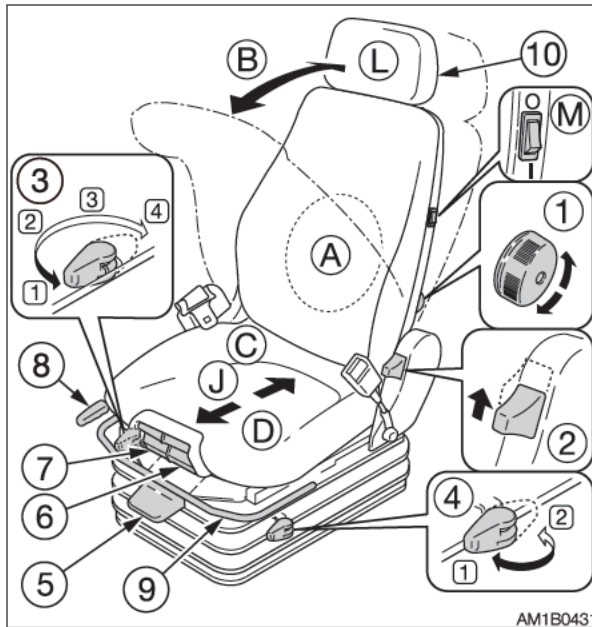

(A) Adjusting the lumbar support

1. Turning the knob (1) in the direction of the arrow causes the lumbar of the backrest to curve outwards.
2. Turning the knob (1) further removes the curve and returns the seat to its original position.

(B) Adjusting the backrest angle

WARNING

- Do not set the backrest to its maximum reclining position and slide the seat backwards at the same time. Doing so may damage the rear window or cause injury.
- Remember that the backrest returns to the forward position abruptly due to the spring force.

1. Sit up and sit back in the chair.
2. Pull up the lever (2), adjust the backrest rear angle by using the spring force on the chair back. Release the lever (2) at the desired angle to secure the backrest.

(C) Adjusting the absorber

The seat adjustment using the absorber is applicable for various traveling conditions on roads or off roads. The cushioning effect can be individually set for each case. Turn the lever (3) to the desired position and release.

Positions between
1: Soft cushioning
and
4: Hard cushioning



CONTROLS SEAT AND SEAT BELT

(D) The fore/aft isolator

It is activated under certain conditions such as crashing. Impacts of crash applied in the operating direction can be well absorbed by the operator's seat. Switching can be done with the lever (4).

Position 1: Fore/aft isolator on

Position 2: Fore/aft isolator off

(E) Adjusting according to operator's weight

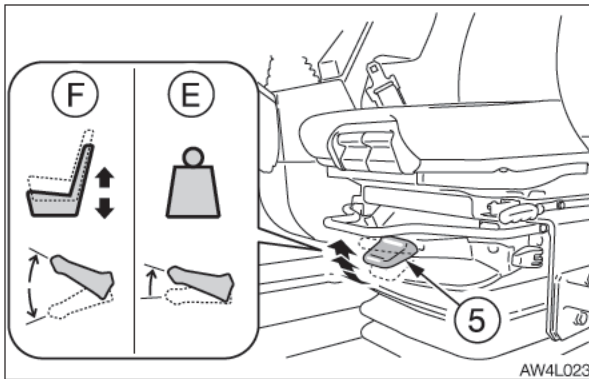

IMPORTANT: Before performing the adjustment by weight, stop the machine and remain seated. Otherwise, the weight cannot be detected, resulting in malfunction.

IMPORTANT: Be sure to set the absorber to the soft cushioning position (1) when performing the adjustment by weight.

The seat should be adjusted according to the operator's weight. Briefly pull the actuator lever (5) of the automatic weight and height adjuster.

(F) Adjusting the seat height

IMPORTANT: Be sure to set the absorber to the soft position (1) when performing the height adjustment.

IMPORTANT: Do not operate the lever (5) (compressor) for one minute or more.

Doing so will cause compressor failure.

To protect the compressor, wait for at least three minutes before operating the lever (5) again.

IMPORTANT: If the height adjustment function fails, first lower the seat to the lowest position. Then, adjust the height again.

The seat height can be steplessly adjusted using the pneumatic mechanism.

To adjust, push up or push down the lever (5) all the way up or down. When the seat reaches the level where it cannot be raised anymore even the lever (5) is pushed up, that level is the highest. If this happens, the height is automatically lowered a small distance to maintain the stroke of suspension.

Adjustment stroke: 80 mm (3.1 in.)

(G) Adjusting the seat pan angle

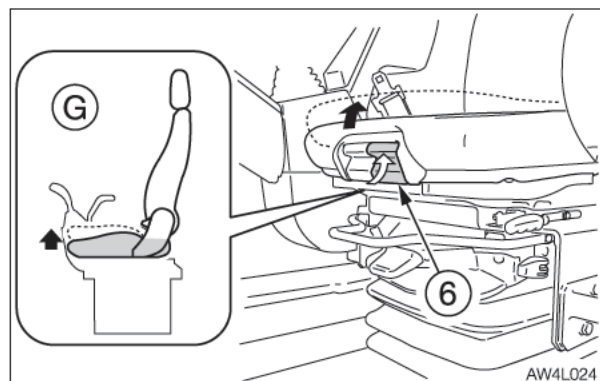

The angle of the seat pan can be individually adjusted.

To adjust, lift the left side handle (6). Use the pressure applied to the seat to set the seat pan to the desired angle.



(H) Adjusting the seat depth

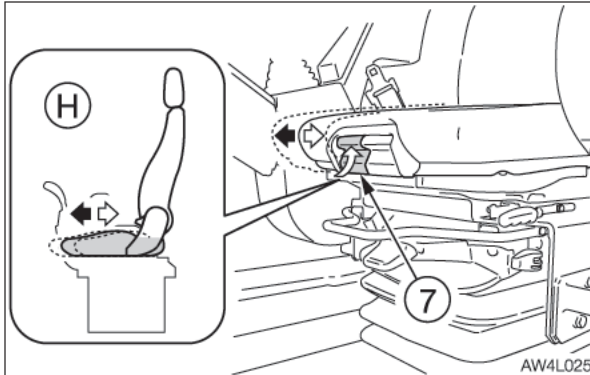

The depth of the seat pan can be individually adjusted.

To adjust, lift the right side handle (7). Move the seat cushion forward or backward until the desired seat depth is obtained.

(K) Adjusting the operating lever stand

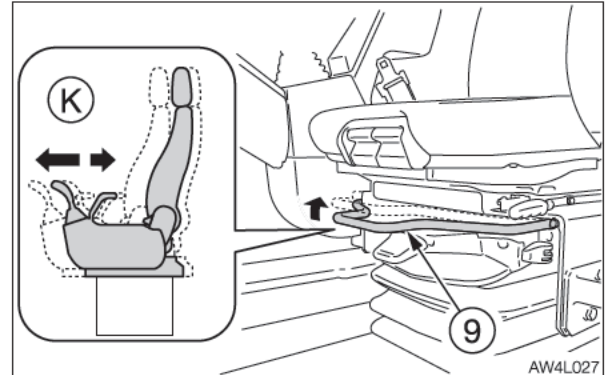

1. Pull up the lever (9) and slide the lever stand (seat).
2. Release the lever (9) at the optimum position to secure the lever stand (seat).
Adjustment range: 9 positions, in 90 mm (3.5 in.)

(J) Adjusting fore-and-aft

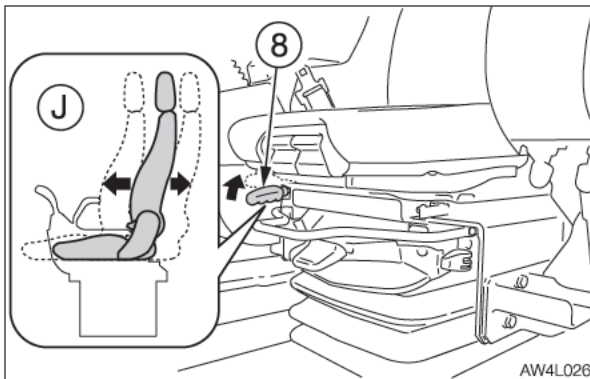

1. Pull up the lever (8) and slide the seat backward or forward to the optimum position for operation.
2. Release the lever (8) at the optimum position to secure the seat.
Adjustment range: 17 positions, in 170 mm (6.7 in.)



CONTROLS SEAT AND SEAT BELT

(L) Adjusting the headrest height

1. Grab the headrest (10) with both hands, and move upward and downward. Adjust the height so that the headrest center is positioned behind your ears.

(M) Seat heater

 **CAUTION**

- Using the seat heater over an extended period of time may cause burns. People feeling ill or having sensitive skin, in particular, should be careful not to do so.
- Do not use it with a blanket or cushion placed on the seat.
- Clean up spilled water or soft drink immediately with a dry cloth. Dry the seat well before using the heater again.

IMPORTANT: The battery voltage becomes low if the seat heater is left on for a long time when the engine is stopped.

O.....OFF
I.....ON



INSTRUMENT CLUSTER

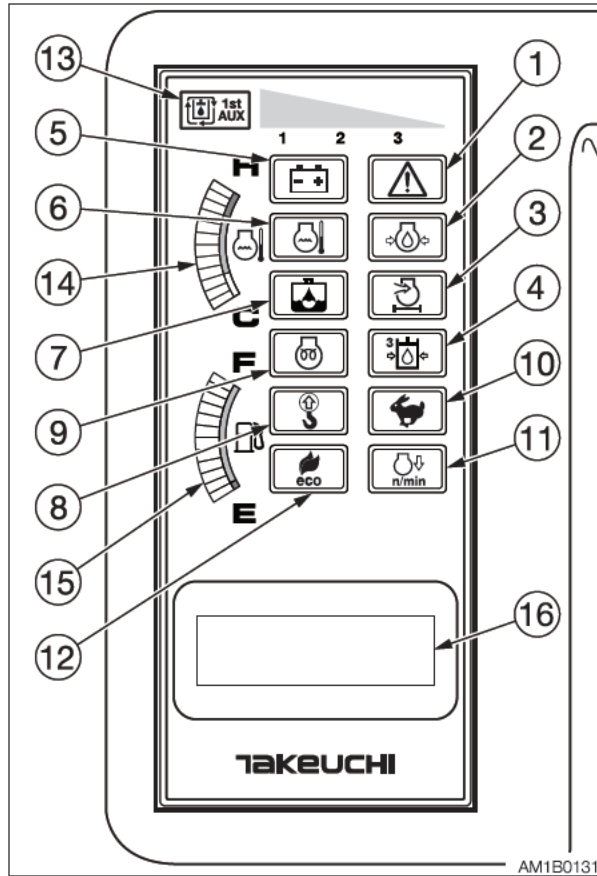

Once the starter switch is turned to ON, all lamps on the instrument cluster light up and the alarm sounds. If any of the lamps are not lit, the globes may be blown. Consult your sales or service dealer.

WARNING LAMPS

IMPORTANT: If a warning lamp flashes and an alarm is sounded, immediately stop all operations and check the corresponding component. Refer to “If a warning lamp flashes” on pages 6-10 and 6-11.

1. Vehicle and engine emergency lamp
While the engine is running, this lamp flashes and an alarm sounds if the engine oil pressure drops, the coolant temperature becomes too high, the charge or the water separator becomes

faulty or the air cleaner becomes abnormal. Get the vehicle or engine error code number from the multi-data display and consult your sales or service dealer referring to the “Vehicle error code list” or “Engine error code list”.

- 2. Engine oil pressure warning lamp**
This lamp flashes and an alarm is sounded if the lubricant oil pressure abnormally low while the engine is running.
- 3. Air cleaner warning lamp**
This lamp flashes and an alarm is sounded if the air cleaner filter is clogged while the engine is running.
- 4. Third auxiliary hydraulic warning lamp**
This lamp lights up and an alarm sounds if the fixed side (left “e”) pressure of the third auxiliary hydraulic line drops abnormally while the engine is running, or while the quick-hitch is being removed or installed.
- 5. Battery charge warning lamp**
This lamp flashes and an alarm is sounded if a problem rises in the charging system while the engine is running.
- 6. Coolant temperature warning lamp**
This lamp flashes and an alarm is sounded if the engine coolant temperature becomes abnormally high while the engine is running.
- 7. Water separator warning lamp**
This lamp flashes if the water is detected within the water separator while the starter switch is in the ON position.
- 8. Overload warning lamp**
This lamp turns on when the overload warning switch is turned on.



INDICATORS

9. Glow lamp

This lamp goes out when the engine preheating is completed.

10. Travel speed lamp

This lamp turns on when the travel speed button is set to the 2nd (high) speed.

11. Deceleration lamp

This lamp turns on when the deceleration button is pressed. It flashes when the auto-deceleration switch is pressed and changes to the “lit” state when the system enters the deceleration mode. While in the “lit” state, it indicates that the engine is in the deceleration mode at low idling speed (1100 rpm).

12. ECO mode indicator lamp

This lamp turns on when the ECO mode switch is turned on. In the ECO mode, the machine drives with reduced engine RPM for lower fuel consumption.

13. Auxiliary 1st flow rate indicator lamp

This lamp lights up to indicate which flow rate setting is selected in the auxiliary 1st.

- 1 Flow rate setting 1
- 2 Flow rate setting 2
- 3 Flow rate setting 3

METERS

14. Water temperature gauge

Indicates the temperature of the engine coolant water.

The LED should be within the green range during machine operation. The red range indicates overheating.

15. Fuel Gauge

Indicates the amount of fuel in the tank.

Be sure to top off the tank before running out of fuel.



MULTI-DATA DISPLAY

16. LCD

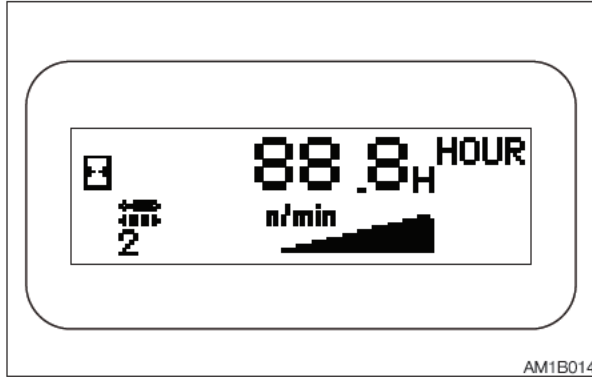

When the starter switch is turned to ON, the display of hour meter, trip meter or the various data related to the machine appears. The initial screen displays the hour meter or the trip meter.

IMPORTANT: If the vehicle or engine emergency lamp flashes and a number appears on the vehicle or engine error code screen, refer to the “Vehicle error code list” or “Engine error code list” and contact your sales or service dealer for help

Trip/Data switch

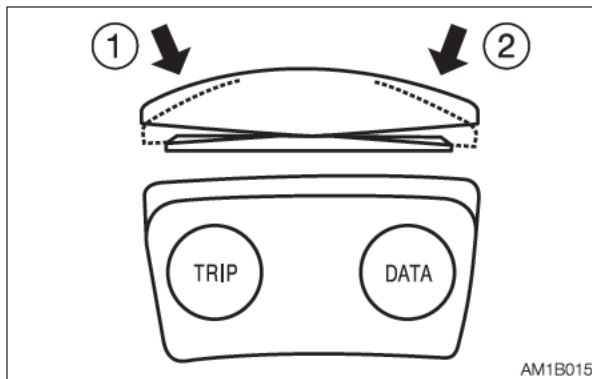

Press either the TRIP (1) side or the DATA (2) side to select a display mode.

- Press the TRIP (1) side to display the hour meter or trip meter.
- Press the DATA (2) side to display the various data.

TRIP MODE DISPLAY

The display changes as the TRIP (1) side is pressed as follows.

When the starter switch is turned on, the mode previously set (before the power-off) is displayed

1. Hour meter



Displays the total engine running time in hours.

The rightmost digit indicates tenths of hours (6 minutes).

Set the inspection and maintenance intervals according to the time displayed on the hour meter.

2. Trip meter



A pattern of desired operating hour can be displayed.

To reset the meter to “0”, press and hold the TRIP side for three seconds.

3. Returns to the hour meter page.



DATA MODE DISPLAY

The display changes each time the DATA (2) side is pressed as follows:
Note that for TB285, “4. Engine oil pressure” and “5. Atmospheric pressure” will not be displayed.

1. Engine RPM



2. Battery voltage



3. Coolant temperature



4. Engine oil pressure



Displays when the machine is TB290.

5. Atmospheric pressure



Displays when the machine is TB290.

6. Auxiliary 1st flow rate

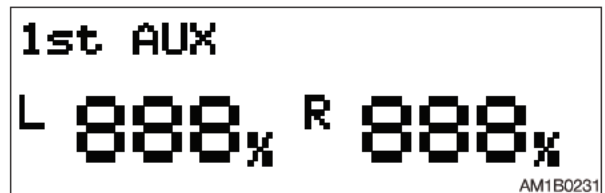

7. Auxiliary 2nd flow rate

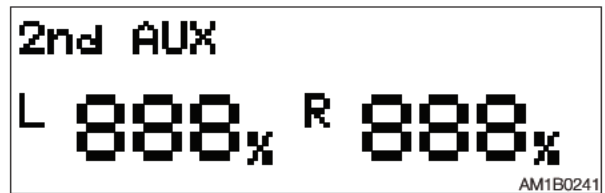

8. Auxiliary 4th flow rate

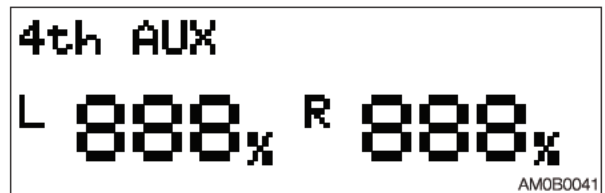

9. Returns to the engine RPM page.



MAINTENANCE MODE DISPLAY

While in the data mode, press and hold the DATA (2) side for three seconds to enter the maintenance mode. The display changes each time the DATA (2) side is pressed as follows:

1. Vehicle error code



IMPORTANT: If an error code appears, immediately stop the operation and contact your sales or service dealer for help.

Displays two three or four-digit error codes, with the latest code in the left.

Refer to "Vehicle error code list" on page 6-12.

2. Engine error code

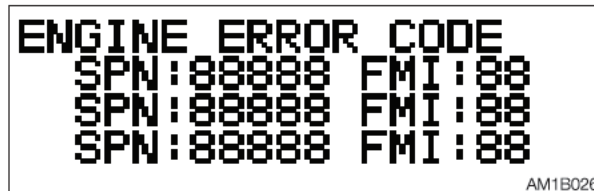

IMPORTANT: If an error code appears, immediately stop the operation and contact your sales or service dealer for help.

Displays three error codes, with the latest code at the top.

Refer to "Engine error code list" on page 6-14.

3. Auxiliary 1st-2 setting information

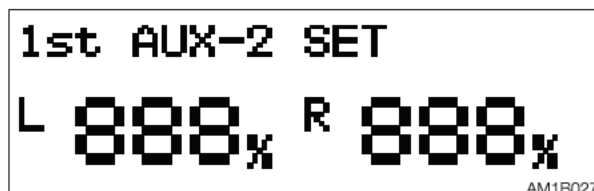

The electric current value in the solenoid that controls the auxiliary flow rate is displayed.

The flow rate, except the flow rate of the auxiliary 1st-1, can be changed when the engine is at rest and the starter switch is set to ON.

The actual flow rate is not in conjunction with the value expressed in percent.

For setting the auxiliary piping flow rate, ask your service or sales dealer.

Changing flow rate

- Raise the safety lock lever to the lock position.
- Press and hold the auxiliary flow rate select switch for approximately three seconds to cause the values displayed on the L side to flash.
- Pressing the TRIP side of the Trip/Data switch decreases the flow rate by 5%. Pressing and holding it for one second decreases the flow rate by 5%. Pressing the DATA side of the Trip/Data switch increases the flow rate by 5%. Pressing and holding it for one second increases the flow rate by 5%.

Initial condition	L	R	Variable range
Auxiliary 1st-1	100%	100%	—
Auxiliary 1st-2	75%	75%	10 to 100%
Auxiliary 1st-3	50%	50%	10 to 100%
Auxiliary 2nd	100%	100%	10 to 100%
Auxiliary 4th	100%	100%	10 to 100%

The table shows the electric current values.

- Press the auxiliary flow rate select switch to confirm. At this time, the values on the R side start flashing. Perform the same operation as for the L side. The section to be set changes each time the auxiliary flow rate select switch is pressed.



- e. Press and hold the auxiliary flow rate select switch for approximately three seconds to end flow rate changing operation.

4. Auxiliary 1st-3 setting information

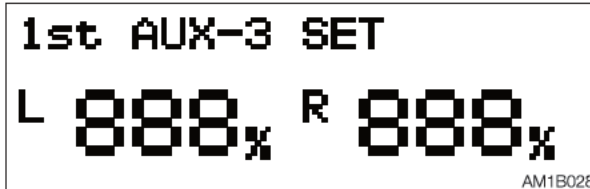

Refer to "Auxiliary 1st-2 setting information" above.

5. Auxiliary 2nd setting information

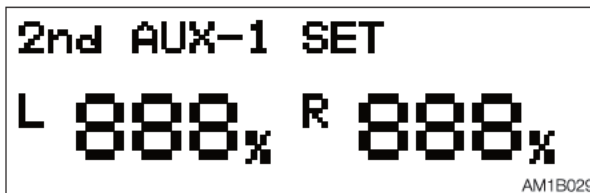

Refer to "Auxiliary 1st-2 setting information" above.

6. Auxiliary 4th setting information

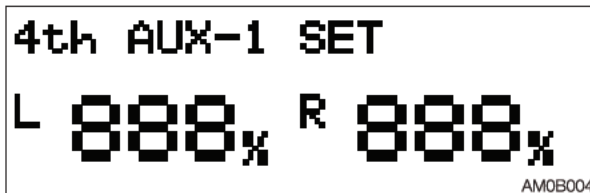

Refer to "Auxiliary 1st-2 setting information" above.
This information is displayed if the auxiliary 4th is equipped.

7. Engine model

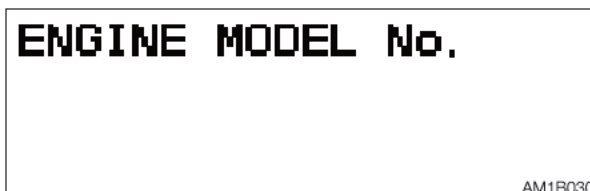

8. Engine serial number



- 9. Returns to the vehicle error code page.



OTHER DISPLAY

1. Swing/Second boom display

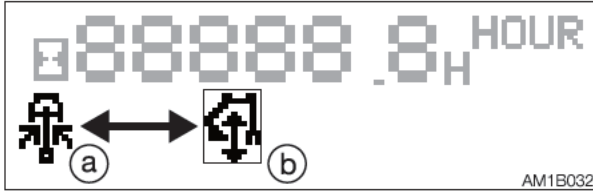

- a: Swing is selected.
- b: Second boom is selected.

2. Auxiliary 2/4 display

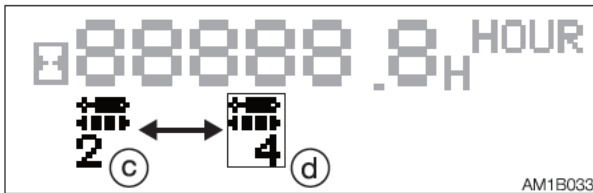

- c: Auxiliary 2nd is selected.
- d: Auxiliary 4th is selected.

Note: If there is no setting for the auxiliary 4th, the auxiliary 2nd will not be displayed.

3. Blade float display



- e: Blade float is selected.

4. Engine RPM display

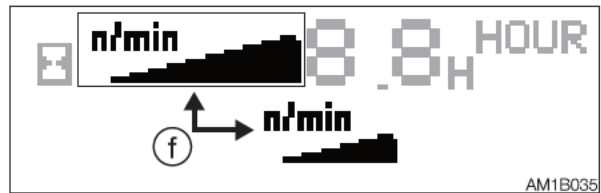

- f: The graph changes as the engine RPM changes.



5. Hour meter/Trip meter display



g: Hour meter is selected.
h: Trip meter is selected.

8. Overload warning display



j: Overload warning switch is on.

6. ECM warning display



IMPORTANT: If the ECM warning display flashes and a number appears on the engine error code screen, refer to the “Engine error code list” and contact your sales or service dealer for help.

This warning display flashes if the Electronic Control Module (ECM) detects an engine problem while the starter switch is in the ON position. The data screen appears with an ECM error code indicating the problem just detected. Refer to “Engine error code list” on page 6-14.

7. Highland mode display



i: Highland mode is selected.



SWITCHES

STARTER SWITCH

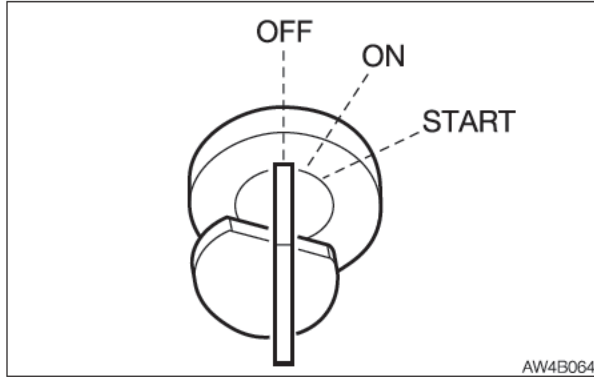

IMPORTANT: Do not repeatedly switch the key from OFF to ON and ON to OFF over a short period. Doing so will cause engine breakdown.

OFF Position for stopping the engine and inserting or removing the key.

ON Position in which the engine is running. At this position, all the electrical equipment is functional. When the coolant temperature is too low, the engine is automatically preheated.

START Position for starting the engine. When the key is released, the switch automatically returns to the ON position.

ENGINE SHUTDOWN SWITCH

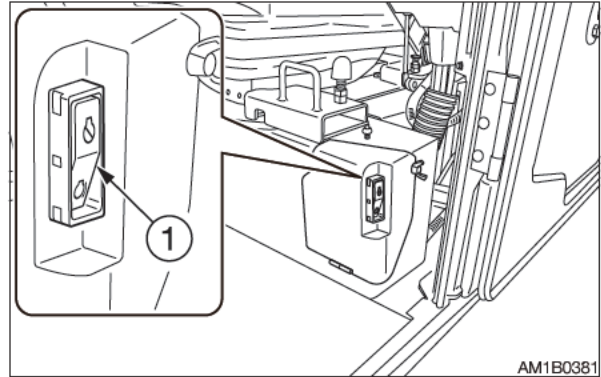

This switch is used to shutdown the engine if it fails to stop, due to machine failure or breakage, when the starter switch is set to the OFF position.

1. Press the switch (1).
2. After use, reset the switch (1).

THROTTLE CONTROLLER

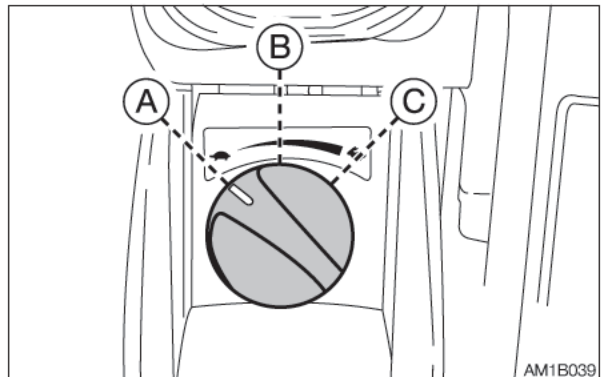

This controls the engine speed.

- (A).....Low idling
- (B)Medium speed
- (C)Maximum speed



HORN BUTTON

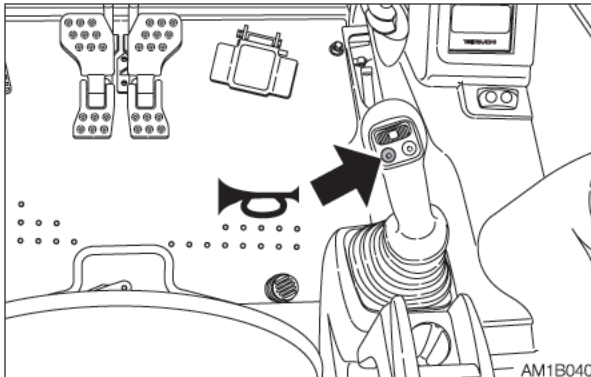

Press the button situated on the right operating lever to blow the horn.

DECELERATION BUTTON

WARNING

Before operating the deceleration button, set the operating lever to the neutral position and take your foot off the pedals. If the deceleration button is pressed while driving, the machine's operating speed will abruptly change to result in a dangerous situation.

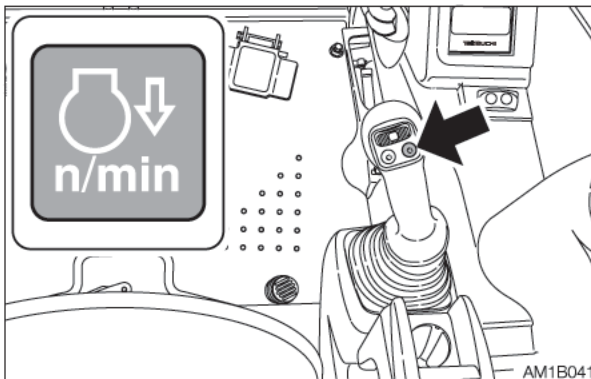

Press this button on the right operating lever to lower the engine speed to low idling. Press the button again to return to the engine speed set with the throttle controller. For safety reasons, it is designed that the deceleration function is activated to set the engine revolutions to low idling whenever the engine is started. Cancel the deceleration mode by pressing the deceleration button as necessary.

This deceleration button operation has priority even if the auto-deceleration switch is turned on.

Note: This deceleration button is capable of decreasing the engine speed and reducing the fuel consumption, with a simple operation, in a situation such as when little engine output is required and thus the operating or the travel levers are in neutral.

TRAVEL SPEED BUTTON

WARNING

When a load greater than a set value is applied while traveling in 2nd (high) speed, the speed will automatically slow down to 1st (low) speed. When the load becomes lighter, the speed will increase and return to 2nd (high) speed. Remember that the travel speed changes depending on the load condition.

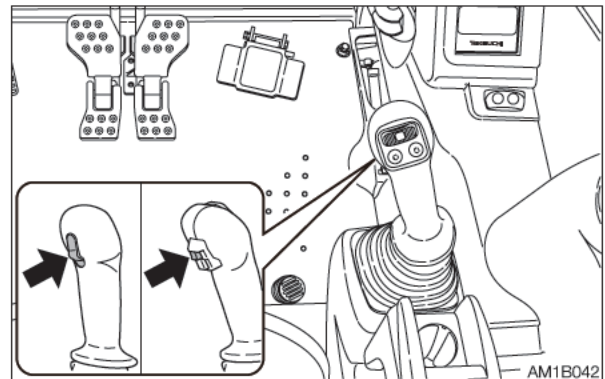

Press this switch to set the travel speed to 2nd (high) speed. Press it again to return to 1st (low) speed.



AUXILIARY 1ST SWITCH

Auxiliary hydraulic buttons

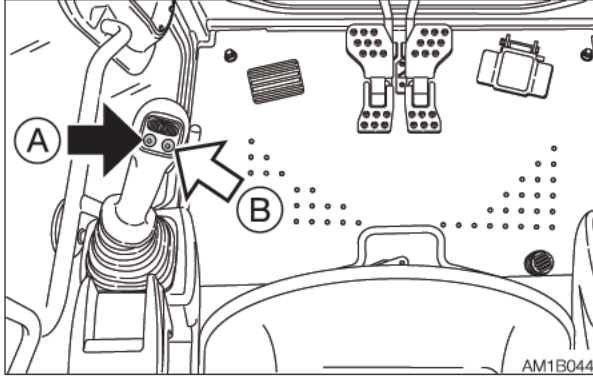

Press those buttons to control the flow of the oil in the first auxiliary hydraulic lines.

- Proportional control of the auxiliary hydraulic circuit is not possible.

- (A).....Hydraulic oil flows to the left auxiliary line (a).
 (B)Hydraulic oil flows to the right auxiliary line (b).

Slider switch

(Proportional control)

Proportional control allows for slow-to-fast/ fast-to-slow movement of attachment.

Example: If you move the slider switch half way, the attachment will move at approximately one-half the speed.

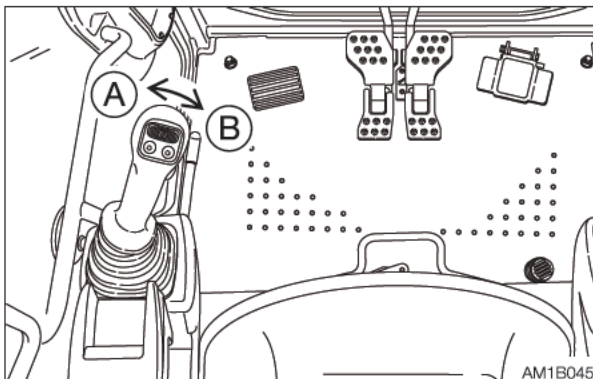

Move this switch to control the flow of the oil in the first auxiliary hydraulic lines.

- (A).....Hydraulic oil flows to the left auxiliary line (a).
 (B)Hydraulic oil flows to the right auxiliary line (b).

Refer to “Auxiliary hydraulic lines” on page 2-46 to 50.

AUXILIARY 2ND/4TH SWITCH

Slider switch

(Proportional control)

Proportional control allows for slow-to-fast/ fast-to-slow movement of attachment.

Example: If you move the slider switch half way, the attachment will move at approximately one-half the speed.

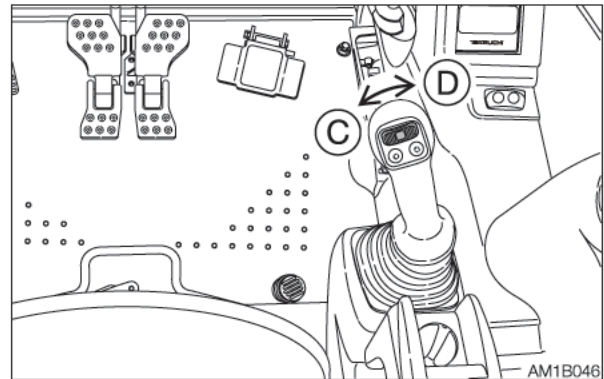

Move this switch to control the flow of the oil in the second auxiliary hydraulic lines.

- (C):Hydraulic oil flows to the left auxiliary line (c).
 (D):Hydraulic oil flows to the right auxiliary line (d).

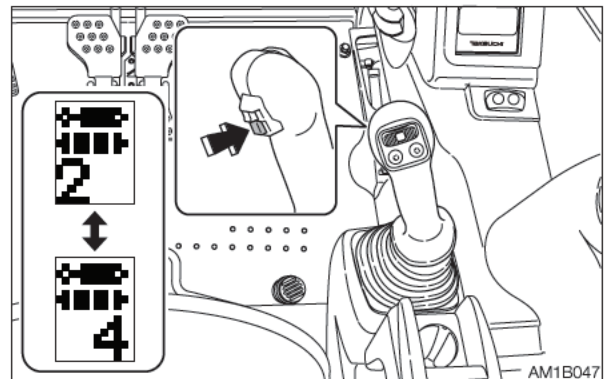

To use the auxiliary 4th hydraulic line, press the auxiliary 2/4 select button to change to the operation of the auxiliary 4th.

Refer to “Auxiliary hydraulic lines” on page 2-46.



SWING/SECOND BOOM SELECT BUTTON

WARNING

Turning on this switch while the boom swing pedal is depressed is dangerous, as the attachment may move unexpectedly. Always set the boom swing pedal back to the neutral position before operating the select switch.

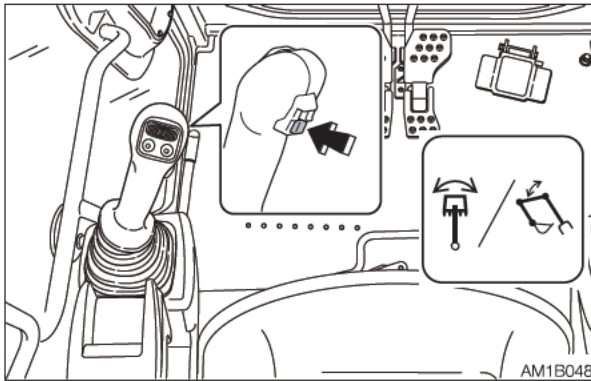

This switch is used to select either the boom swing operation or the second boom operation.

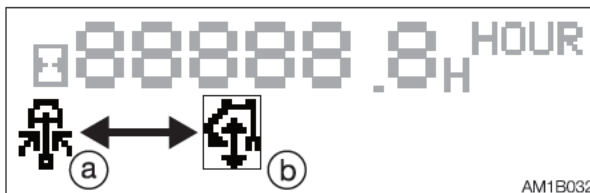

When the switch is turned on, the second boom display (b) appears on the LCD to indicate that the second boom operation is enabled. When the switch is turned off, the display is changed to the boom swing to indicate (a) that the boom swing operation is enabled.

The actual boom swing operation is performed with the boom swing pedal. Refer to “Boom swing pedal” on page 2-33.

THIRD AUXILIARY HYDRAULIC BUTTON

Refer to “Third auxiliary hydraulic switch and button” on page 2-49.

AUXILIARY 2/4 SELECT BUTTON

Refer to “Auxiliary 2/4 select button” on 2-50.



WIPER SWITCH

IMPORTANT: If no washer fluid is discharged, do not operate the washer. Doing so may damage the pump.

IMPORTANT: Operating the wiper with no moisture on the windshield will scratch the glass. Use water or washer fluid when operating the wiper.

IMPORTANT: In cold climates, the wiper blade may freeze to the glass. Operating the wiper forcibly may damage the wiper motor.

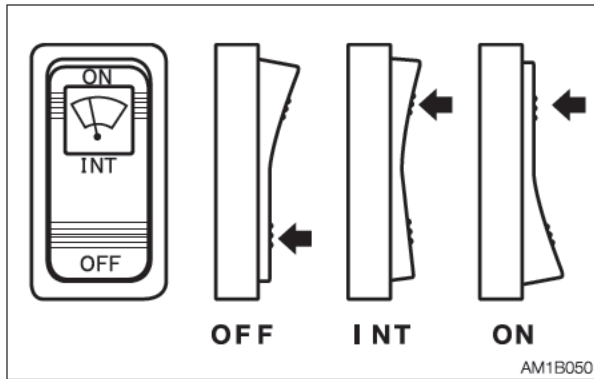

OFFOff
 INTIntermittence operation
 ONContinuous operation

WASHER SWITCH

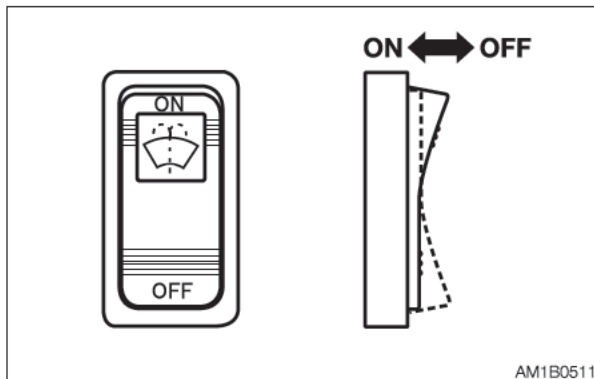

ONPressing the ON side of the switch causes the washer to spray washer fluid. To stop spraying, release the switch.

AUTOMATIC DECELERATION SWITCH

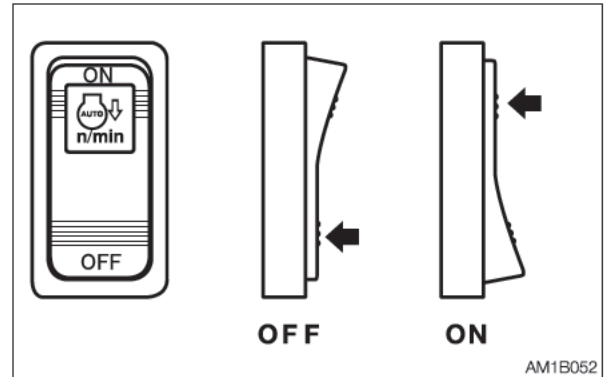

When the ON side of the switch is pressed, the deceleration lamp in the instrument cluster flashes. This flashing stops when the deceleration function starts working, and the lamp remains lit while in the deceleration mode. The engine speed automatically drops to low idle (deceleration mode) four seconds after the control levers are set to neutral, to reduce fuel consumption. Moving the control levers will cause the speed to return to the original engine speed.

It is not possible to use the deceleration button at the same time. The auto-deceleration switch has priority over the deceleration button. Switching from the deceleration button to the auto-deceleration switch will first return to the engine speed set with the throttle controller. Then, the engine will automatically enter the deceleration mode (low idling) if the control levers are not operated within four seconds.

This automatic deceleration function is canceled when the starter switch is turned to the OFF position.



ECO MODE SWITCH

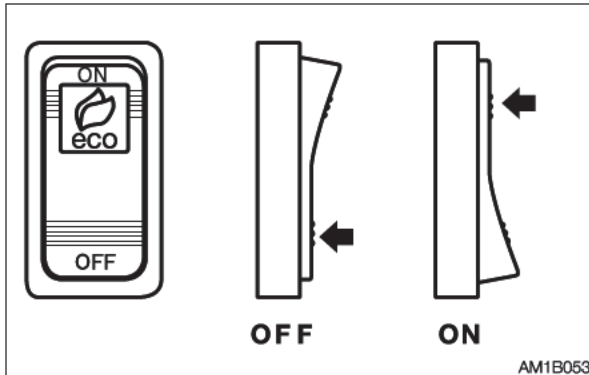

When the ON side of the switch is pressed, the ECO mode lamp in the instrument cluster lights up. The engine RPM and hydraulic horse power are set to economically optimal values to improve the fuel economy.

HIGHLAND MODE SWITCH

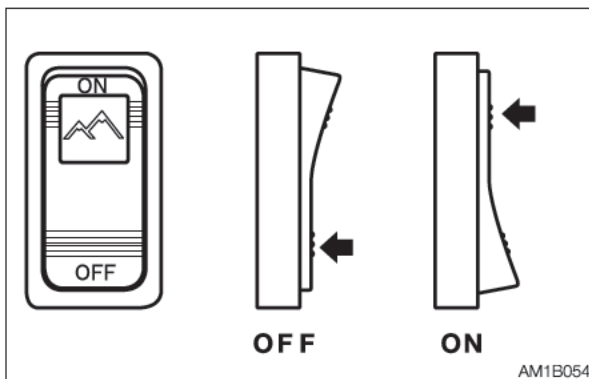

This switch is used to reduce the engine load due to the hydraulic pump. If the machine is operated at a high-altitude site, the engine output is decreased due to thin air. In such cases, the hydraulic horse power is automatically adjusted to prevent the engine from stalling. Use this switch if the machine is operated at a high-altitude site.

OFFLowland
ONHighland

AUXILIARY 1ST FLOW SELECT SWITCH

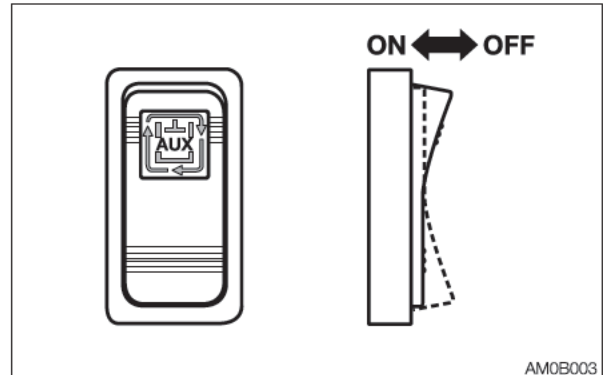

This switch is used to select and set the flow rate of the auxiliary 1st. The auxiliary 1st flow rate indicator lamp in the instrument cluster lights up to indicate which flow rate setting is selected. The flow rate setting changes each time the ON side of the switch is pressed. The flow rate setting is done by using this switch and the TRIP/DATA switch. Refer to "3. Auxiliary 1st-2 setting information" on page 2-20.

DETENT MODE SWITCH (AUXILIARY 1ST)

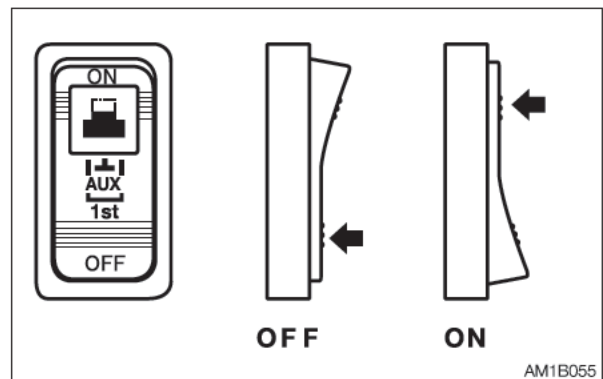

IMPORTANT: Do not operate the machine in the detent mode for a long time. Doing so will increase the hydraulic oil temperature and shorten the service life of the hydraulic units.

This switch is used to change the operation mode of the auxiliary 1st button (A). Pressing the ON side of the switch causes the auxiliary button (A) to enter the detent mode.



CONTROLS SWITCHES

Pressing the OFF side changes to the momentary mode.

LIGHT SWITCH

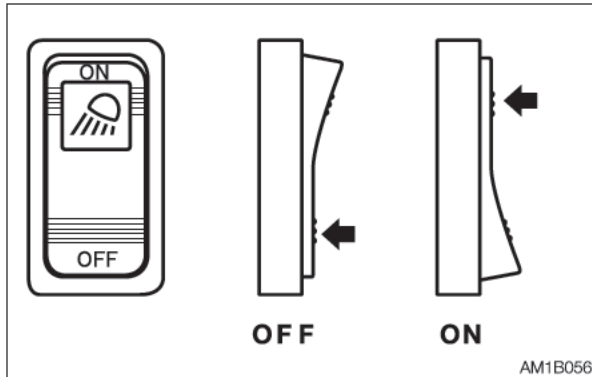

When this switch is turned while the starter switch is at ON, the lights turn on as follows:

OFFOff

ONInstrument cluster light, switch lamps, front light, boom light, side lights and tail lamps will be lit.
(switch lamp is lit)

OVERLOAD WARNING SWITCH

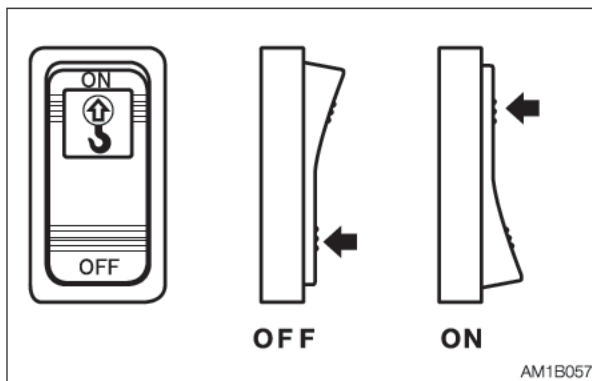

WARNING

If the overload is not removed after the overload warning horn is sounded, the machine may tip over or the emergency shut-off valve may be activated. If the horn starts sounding, stop operating the machine and lighten the load.

If a weight greater than the lifting capacity is applied or lifted, the overload warning device

is activated and the horn sounds. (When the overload warning switch is turned on.)

OFFOff

ONOn

If the emergency shut-off valve is activated, the overload warning horn stops.
(This is because the pressure sensor can no longer detect hydraulic pressure.)

BEACON LAMP SWITCH

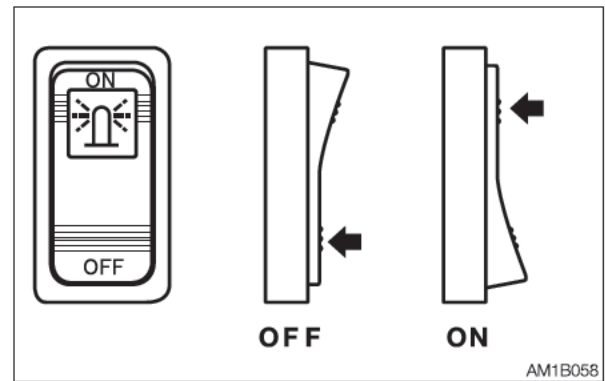

When this switch is turned on while the starter switch is at ON, the lamp turns on as follows:

OFFOff

ONBeacon lamp is lit



LEVERS AND PEDALS

SAFETY LOCK LEVER

WARNING

- Before standing up from the operator's seat to open/close the window or remove/install the lower window, lower the working equipment to the ground, raise the safety lock levers to engage the lock and stop the engine. If any controls should be accidentally touched when the safety lock levers is lowered (unlocked), the machine will suddenly move and cause serious injury or death.
- Be careful not to touch the operating levers when raising or lowering the safety lock lever.
- Before leaving the operator's seat, lower the working equipment to the ground, raise the safety lock levers to engage the lock and stop the engine. Also, be sure to remove the key, lock the door and covers, take it with you and store it in a specified place.

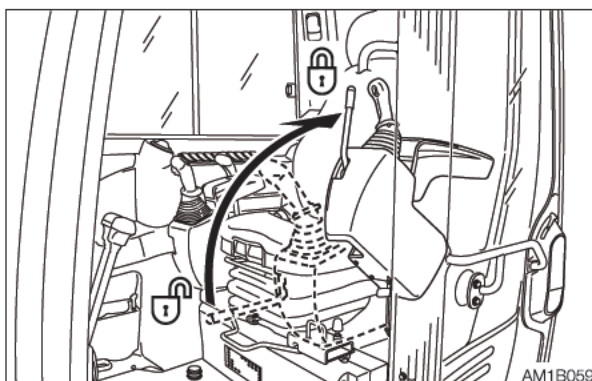

This device is for locking the operations of hoe attachment, slewing, auxiliary, dozer blade and traveling.

When the lever is raised, the lever stand springs up to lock the lever.

OPERATING LEVERS

WARNING

- Before starting operation, carefully check which lever pattern you are going to use.
- It is described using the ISO pattern in this manual.

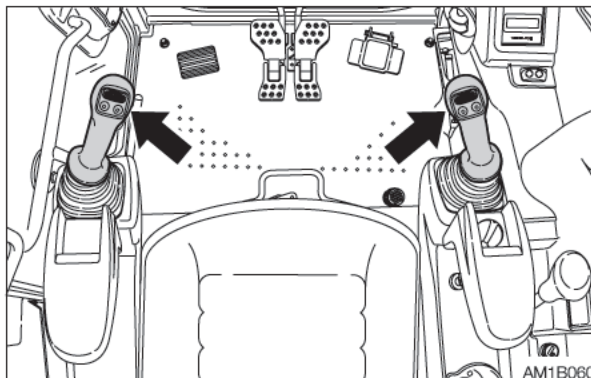

Use these levers to operate the boom, arm, bucket and upperstructure.

Refer to "Lever pattern" on pages 3-6 and 3-7.

Refer to "Operating the working equipment" on pages 3-14 and 3-15.



BLADE LEVER

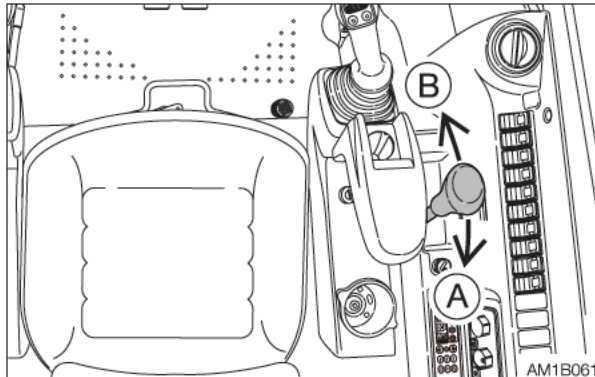

Use this lever to operate the dozer blade.
(A).....Blade up
(B)Blade down
Refer to “Operating the dozer blade” on page 3-15.

Machines with the float switch (USA specification)

WARNING

- Do not press the float button while the machine is raised by the blade. Doing so will cause the machine to fall. If you must work beneath the raised machine, always use a secure support to keep the machine raised.
- Do not press the float button while the blade is raised. Doing so will cause the blade to fall. Lower the blade to the ground before pressing the float button.
- Do not travel forward while the blade is in the float mode.

Float operation

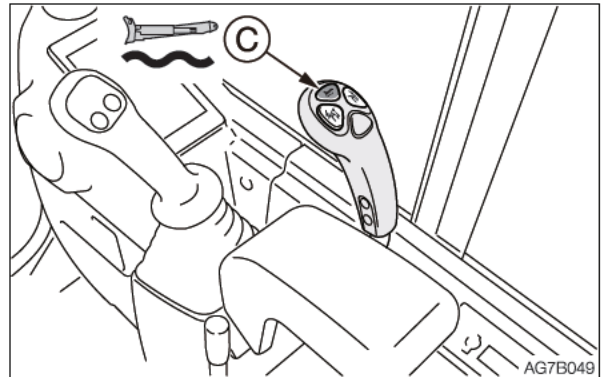

Button (C). Float mode

Press the float switch to set the dozer blade to the float mode.
To cancel the float mode, press the switch again.



TRAVEL LEVERS/PEDALS

WARNING

- Before operating the travel levers/pedals, make sure that the dozer blade is to the front of the operator's seat. Remember that when the dozer blade is to the rear of the operator's seat, the travel levers/pedals must be operated in the reverse direction from when it is to the front.
- Do not rest your foot on the pedal unless operating it for traveling. If the pedal is accidentally stepped while working, the machine may suddenly move and cause serious injury or death.

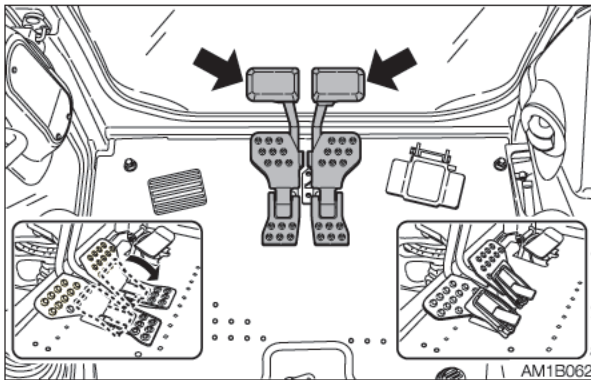

Use these levers/pedals to move forward or backward and to change directions. Fold the pedals when not being used. Refer to "Operating the travel levers" on page 3-10.

BOOM SWING PEDAL

WARNING

Keep the pedal cover to the locked position when not using the pedal. Stepping on a pedal accidentally when it is not locked may cause accidents.

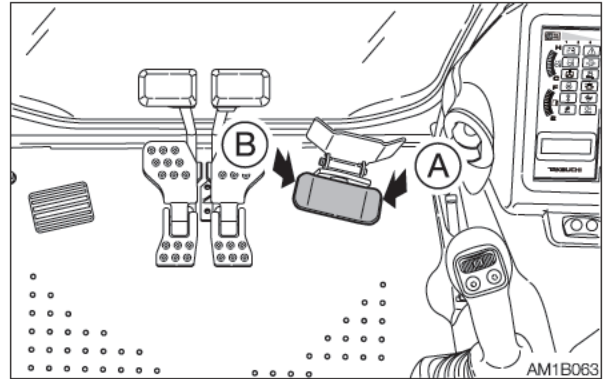

Use this pedal to operate the boom swing. If the 2-piece boom select switch is pressed, the operation will change to the second boom.

(A).....Boom swing right/Second boom raise
(B)Boom swing left/Second boom lower
Refer to "Operating the boom swing" on page 3-15.

Pedal lock

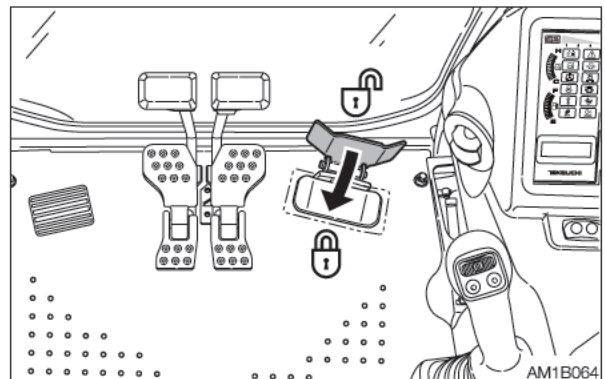

Set the pedal cover over the pedal to lock it. Open the pedal cover from the pedal to unlock it.



ACCESSORIES

AIR CONDITIONER

CAUTIONS ON USE

Ventilate periodically

- When using the air conditioner over an extended period of time, open the windows about once each hour to let in fresh air.
- Your eyes may become irritated if you smoke while using the air conditioner. If this happens, open the windows to let in fresh air. Smoking particularly irritates the eyes when the air conditioner is being used. Since the humidity in the cab drops, the cornea becomes dry.
- If the outside air is dirty, set the air conditioner to the circulation mode.

Always maintain good visibility

Working with the dirty windows or fogged windows restricts visibility and is dangerous. Always clean dirt and moisture off the windows before working.

- The windows tend to get foggy when the humidity is high. If this happens, turn on the air conditioner to use outside air and the defroster to get rid of the fog.
- If the air conditioner is set to high when using the defroster, the difference between the external and internal temperatures increases, resulting in frost on the outside of the windows. If this happens, either turn the air conditioner off or turn the temperature control dial clockwise to increase the internal temperature.
- Mist may blow out of the air outlets. This is not a malfunction. When moist air passes through the evaporator on the air conditioner unit, water particles in the air freeze and are emitted as mist.

Do not overcool

For health reasons, the air inside the cab should be kept at a temperature at which you feel a little cool when entering the cab from outside (a difference of 5 to 6°C (41 to 43°F)). Remember to adjust the temperature properly.

Do not turn on the air conditioner until the engine is started

To avoid placing an excessive load on the compressor, wait until the engine is started and is running smoothly before turning on the air conditioner.

Let hot air out first

If the machine has been parked in the sun, open the windows and door to let the hot air out of the cab before using the air conditioner.

Caution on refrigerant (gas)

If the refrigerant comes in contact with skin or eyes, it may cause frostbite or eye damage. Never touch the refrigerant or loosen the parts on the cooling circuit. If the refrigerant gas leaks, keep flames away.

Off-season inspection

Even off season, run the air conditioner for 3 to 5 minutes at least once a week to maintain oil in the various parts of the compressor.



NAMES OF COMPONENTS

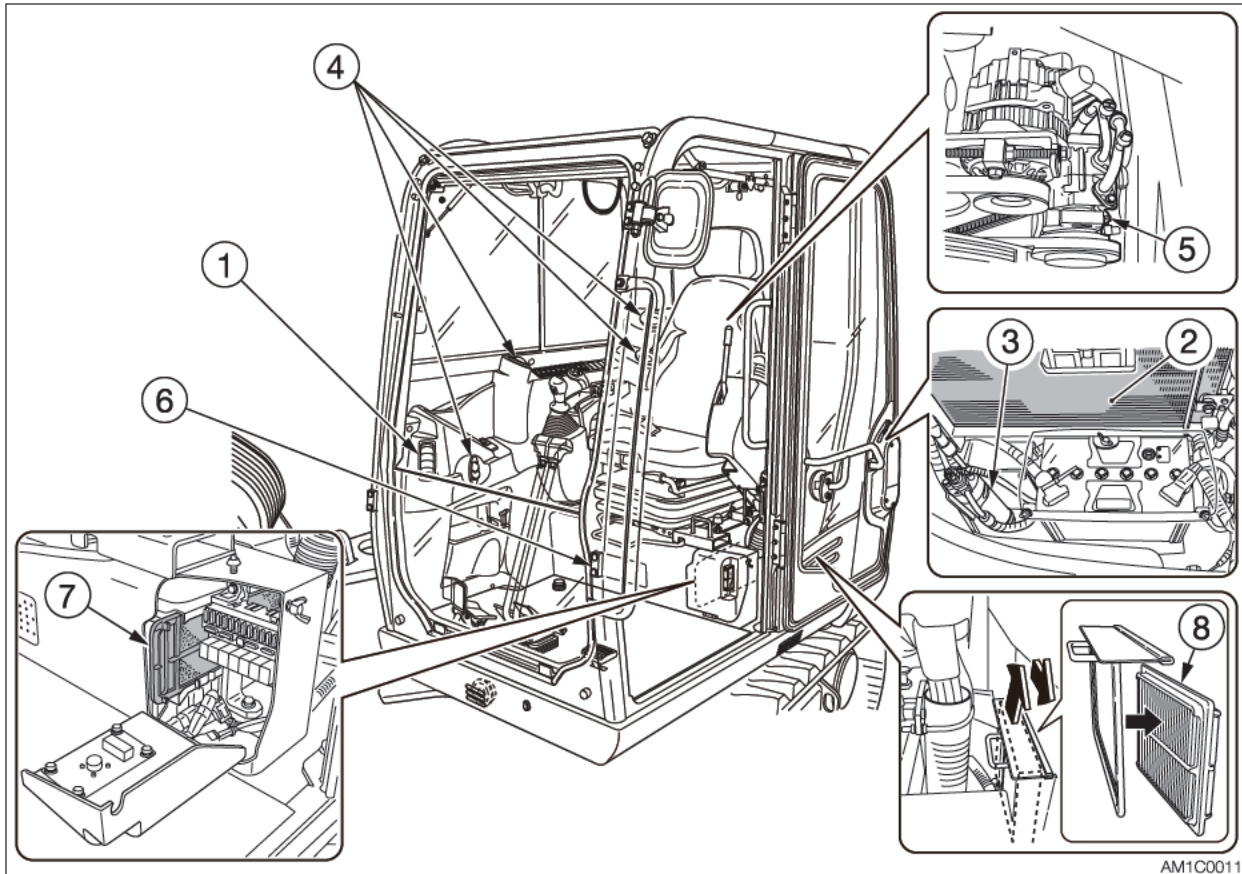

AM1C0011

1. Defroster
2. Condenser
3. Receiver drier
4. Outlets
5. Compressor
6. Air conditioner unit
7. Circulation filter
8. Ventilation filter

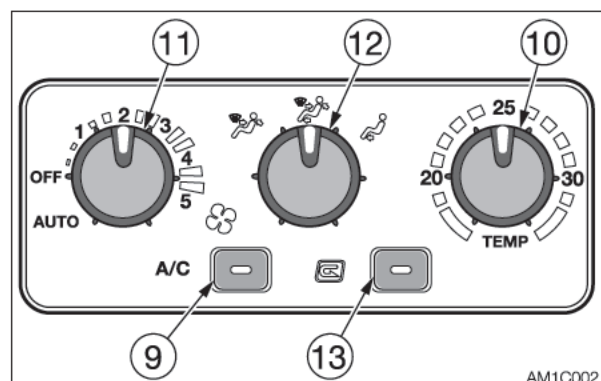

AM1C002

Control panel

9. Air conditioner switch
10. Temperature control dial
11. Fan dial
12. Outlet select dial
13. Ventilation/Circulation select switch



Air conditioner switch

IMPORTANT: To avoid placing an excessive load on the compressor, wait until the engine is started and is running smoothly before turning on the air conditioner.

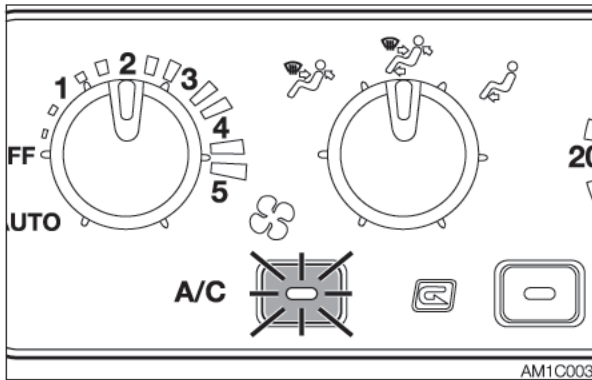

Use this switch to turn on or off the cooling/dehumidifying function. When this switch is pressed while the engine is running with the fan dial set to ON, the lamp lights up and the cooling/dehumidifying function is turned on. Press this switch again or turn the fan dial to OFF to turn off the cooling/dehumidifying function.

Lamp is offOFF

Lamp is onON

Note: To prevent leakage of refrigerant gas from the compressor's seal, operate the air conditioner at least once a week, regardless of the season.

Note: The air conditioner will not function if the temperature in the cab is low (3°C (38°F) or lower).

Fan dial

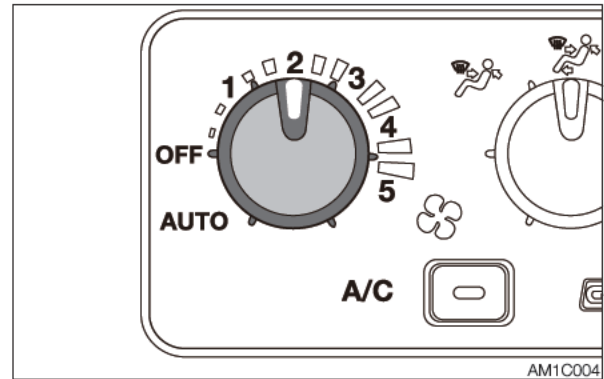

Use this switch to adjust the fan speed in five steps. Turning this switch to the OFF position turns off the air conditioner.

AUTO The airflow rate can be automatically adjusted based on the position of the temperature control dial.

OFF Turning off the fan and the air conditioner.

1 to 5 A larger number indicates larger airflow rate.

Temperature control dial

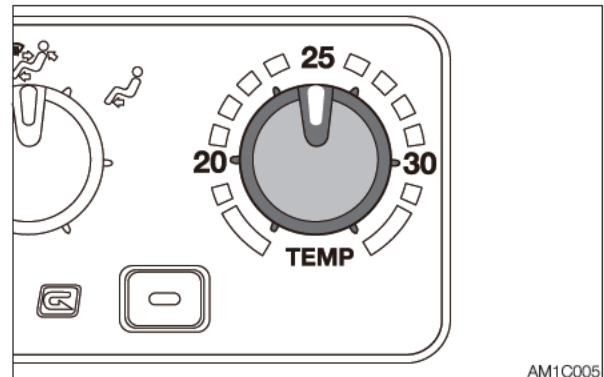

Use this dial to adjust the air temperature. Turn the dial clockwise to increase the temperature. Turn the dial counterclockwise to decrease the temperature.

Note: No warm air is emitted if the temperature of the engine coolant is low.



Outlet select dial

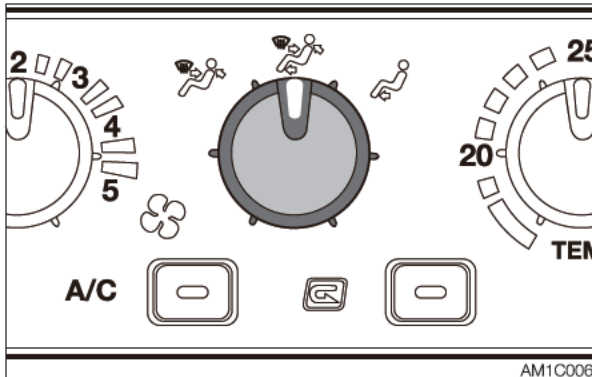

Use this dial to select the desired outlet depending on the purpose of use.

-Air comes from the front and rear outlets.
 -Air comes from the front, rear and foot outlets.
 -Air comes from the foot outlet.
- Arrange the air direction at each outlet.

Ventilation/Circulation select switch

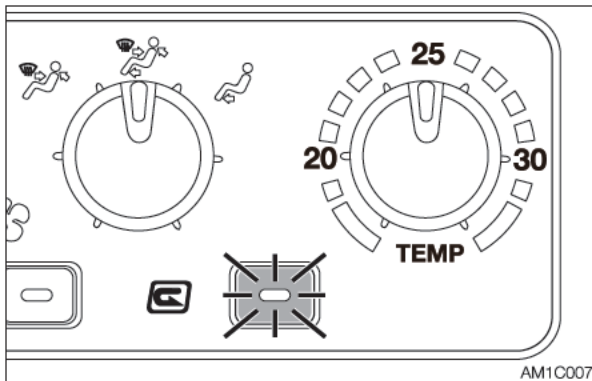

Use this switch to select between Ventilation and Circulation.

Press this switch once to turn on the lamp and set to Circulation. Press this switch again to turn off the lamp and set to Ventilation.

Lamp is onCirculation

- Cool or heat the cab quickly
- When external air is dirty

Lamp is offVentilation

- Lets in fresh air
- Removes frosting from the windows
- Ventilates while cooling or heating

Outlets

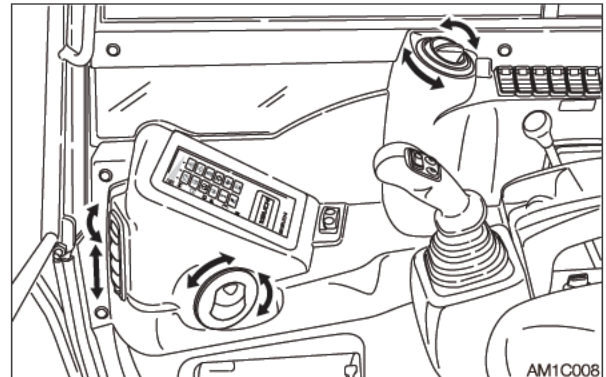

Move the louvers up and down or left and right to adjust the air flow direction and amount.

Operation

Dehumidifying and Heating (in cold climates or when the humidity is high)

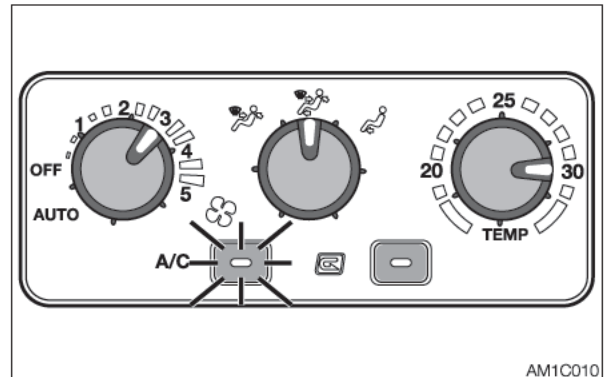
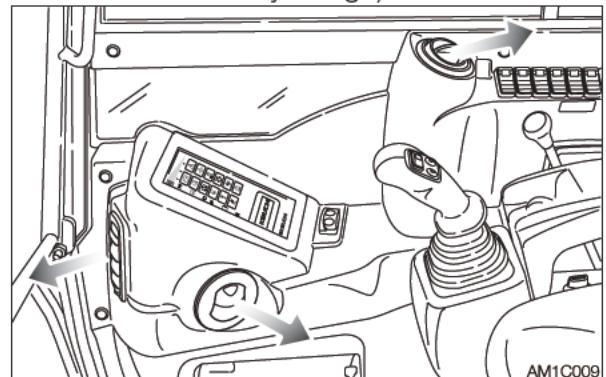

Arrange the foot outlets and the defroster so that they are directed to the front window. Let the dehumidified warm air blow on the front window, to prevent frosting.

1. Set the desired temperature by turning the temperature control dial to between the center and the right end.
2. Set the fan dial to the desired position.



Cooling

CAUTION

- When the air conditioner is set to the circulation mode, the air in the cab gradually becomes dirty. Switch to the “ventilation” to ventilate once a comfortable temperature is obtained.
- Excessive cooling can be harmful to your health. It is best to keep the air inside the cab only about 5 to 6°C (41 to 43°F) cooler than the outside air.
- If the machine has been parked in the sun, open the windows and door to let the hot air out of the cab before using the air conditioner.

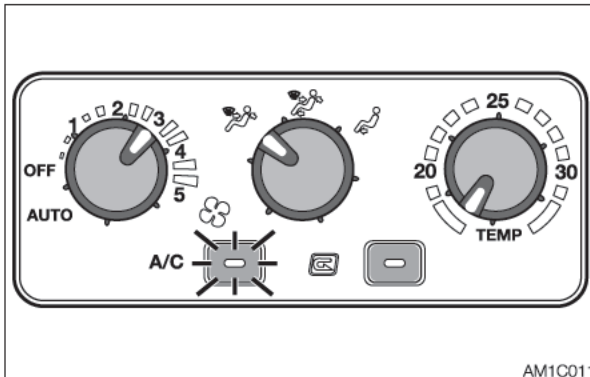

1. Turn the air outlet dial to the FACE or FULL position.
2. Set the desired temperature by turning the temperature control dial to between the center and the left end.
3. Set the fan dial to the desired position.

Quick cooling

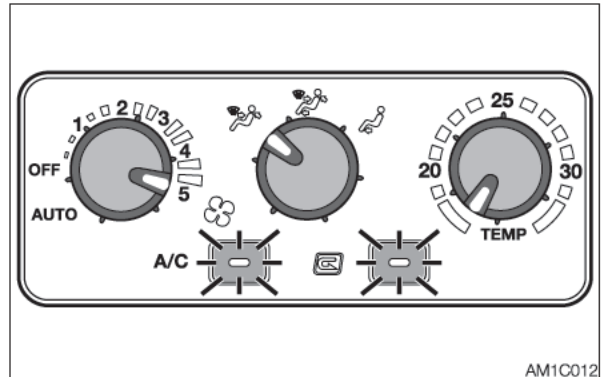

1. Turn the air outlet dial to the FACE or FULL position.
2. Turn the temperature control dial to the left end.
3. Set the fan dial to “5”.
4. Press the Ventilation/Circulation select switch to set to circulation.

Heating

1. Turn the air outlet dial to the FOOT position.
2. Set the fan dial to the desired position.
3. Set the temperature control dial to the desired position.
For the highest temperature, turn the dial all the way to the right.
4. Turn the fan dial to the OFF position to turn off heating.



Defrosting the windows

Note: If the air conditioner fan is set to High when using the defroster, the difference between the external and internal temperatures increases, resulting in frost on the outside of the windows. If this happens, either turn off the air conditioner or turn the temperature control dial clockwise to increase the internal temperature.

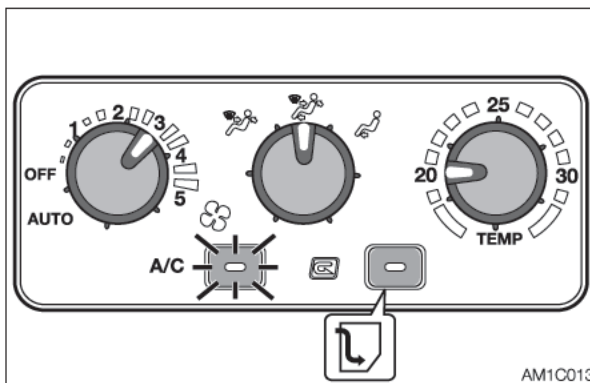

1. Set the desired temperature by turning the temperature control dial to between the center and the left end.
2. Set the fan dial to the desired position.
3. Press the Ventilation/Circulation select switch to set to ventilation.
4. Arrange the foot outlets and the back outlets of the defroster so that they are directed to the front window.

CUP HOLDER

CAUTION

- Drinks may be spilled due to vibration when the machine is operating or traveling. Be particularly careful not to burn yourself with hot drinks.
- Note that the cigarette lighter or other electric parts may be damaged if drinks are spilled on them.

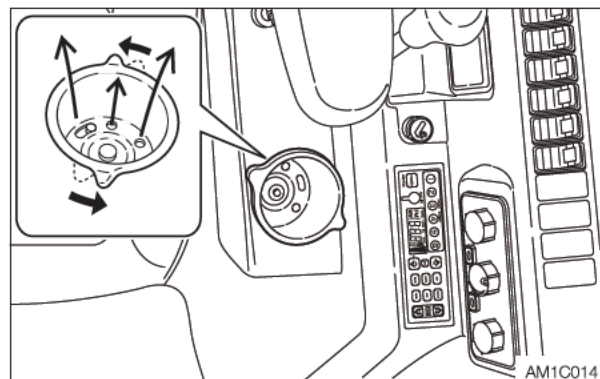

Use to hold cups or bottles.

To warm or cool the cup, turn the cup holder in counterclockwise. Warm or cool wind blows from the bottom of the cup holder.



CIGARETTE LIGHTER

⚠ WARNING

- Do not leave the cigarette lighter knob pushed in for a long time. Doing so heats up the lighter, and could be dangerous.
- If the lighter knob does not pop out 30 seconds after it was pushed in, it may be broken. Pull it out by hand.
- Do not use any other cigarette lighters than Takeuchi's. They could be stuck in the middle and not pop out.
- Use only those electric products which comply with the specifications of this socket.
- Do not touch the metallic parts of the lighter. Doing so could cause burns.

This is the cigarette lighter and internal power supply socket. When using, be careful not to exceed 12V/5A.

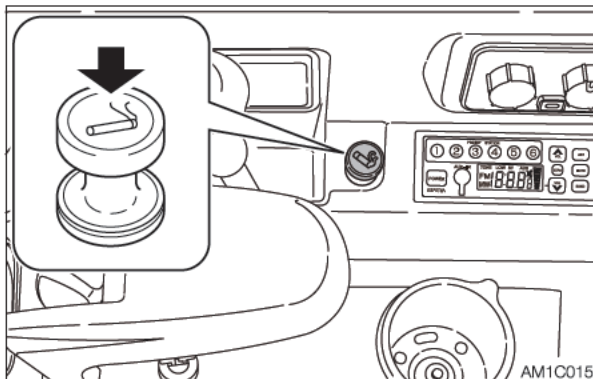

1. Push the lighter in.
2. Release the lighter and wait for it to pop out. The lighter pops out automatically when the heater becomes red hot.
3. Once the lighter pops out, pull it out.

ASHTRAY

⚠ WARNING

- Be sure to extinguish cigarettes and matches completely before putting them in the ashtray, and close the ashtray after each use.
- Do not overfill the ashtray with cigarette butts or put in paper or other easily burnable objects. Doing so could cause fire.

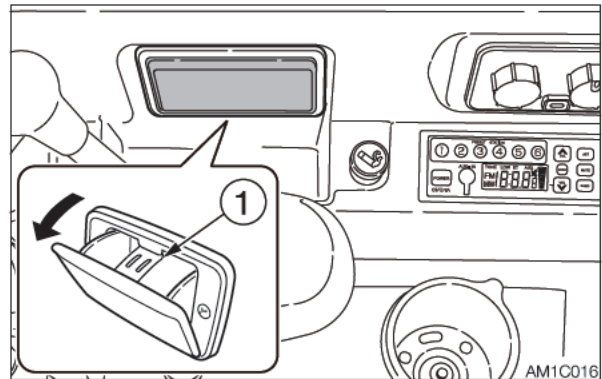

Pull the ashtray out towards you to use it. To clean, press the ash discharge button (1) and pull out the ashtray.



INTERIOR LIGHT

IMPORTANT: The battery capacity decreases if the interior light is left on for a long time when the engine is stopped.



OFFRemains off all the time.
ONLights up all the time.

MIRRORS

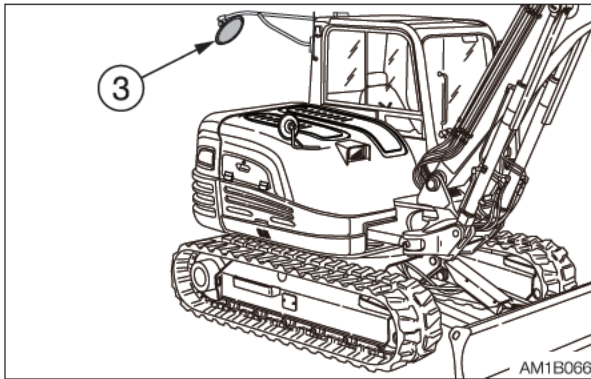
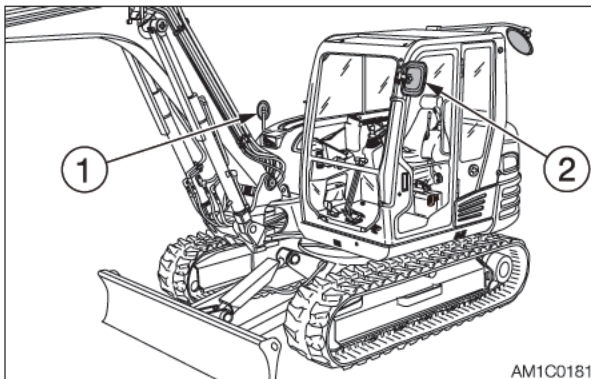

Adjust the rear view mirrors and side view mirrors so that you have a better view.

1. Check the rear right side view
2. Check the rear left side view
3. Check the rear view.

EXTERNAL POWER SOCKETS

WARNING

Use only those electric products which comply with the specifications of these sockets.

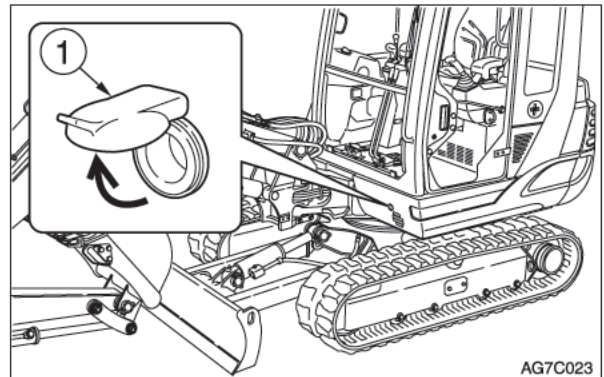

For beacon

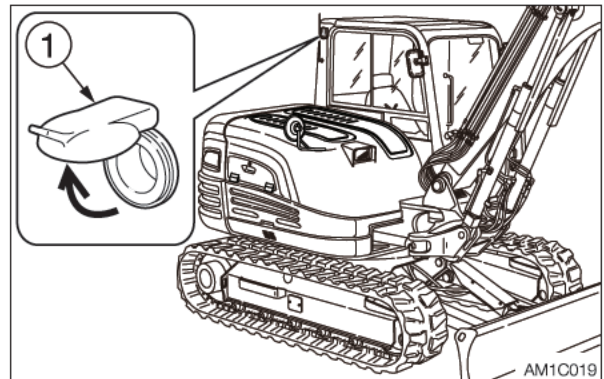

Use these sockets to connect the external power supply. When using, be careful not to exceed 12V/5A.

To use, open the cap (1).



RADIO (FOR CAB)

CAUTIONS ON USE

- To ensure safe operation of the machine, always be sure to keep the volume of the radio down to a level where you can easily hear sounds from outside the machine.
- Do not use the radio for a long time when the engine is stopped. Doing so will drain the battery and make it difficult or impossible to restart the engine.
- Be careful not to allow water or other liquids to come into contact with the radio. Otherwise, it may result in malfunction.

NAMES OF COMPONENTS

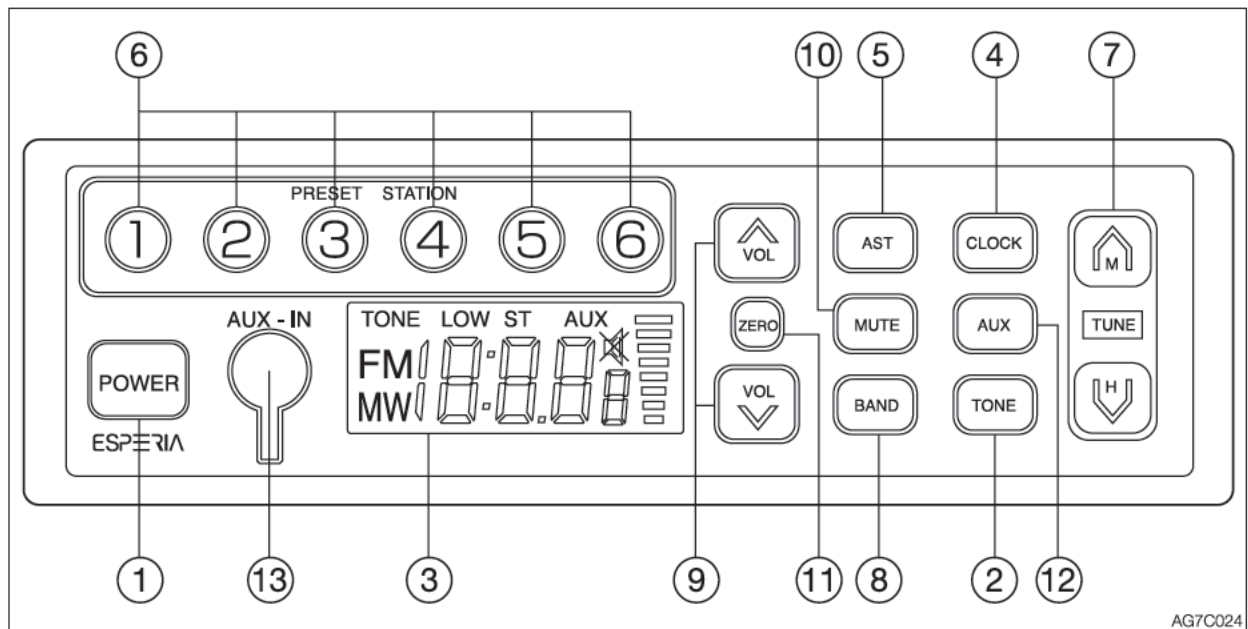

AG7C024

- (1) POWER button**
Use this button too turn on or off the radio.
- (2) TONE control button**
Use this button to select the tone. Press the button to select low tone. The TONE LOW display appears on the LCD. Press the button again to select high tone.
- (3) LCD**
Displays the time/the receiving frequency and the operation mode.
- (4) CLOCK button**
Use this button to switch between the clock display and the receiving frequency display on the LCD. If this button is not pressed for six seconds while the frequency is displayed, the LCD returns to the clock display.
- (5) AST button**
Use this button to automatically seek the station information, store it into memory and assign each preset button (1 to 6) a station.
- (6) PRESET STATION buttons (1 to 6)**
Use these buttons to store station information. Each button can store information on one FM station and one AM station. For how to use these buttons, refer to "Presetting stations".



(7) TUNE button

Use this button to tune to a radio station. Press and hold this button (▲) or (▼) for two seconds or more to start seeking the audible stations. The seeking stops when a station is found. To cancel tuning in progress, press the button again. Pressing the (▲) button will start seeking stations with higher frequency. Pressing the (▼) button will start seeking stations with lower frequency. The frequency will continuously be increased/decreased if the (▲) or (▼) button is held pressed.

(8) BAND button

Use this button to select FM or AM. The selected band and the receiving frequency will be displayed on the LCD.

(9) VOL buttons

Use these buttons to control the sound volume. Press the button (▲) to increase the volume and the button (▼) to decrease the sound volume. Press and hold each button to continuously increase/decrease the volume.

(10) MUTE button

Use this button to temporarily turn off the sound output. If pressed, the “mute is on” mark  appears on the LCD. Press this button again to cancel mute.

(11) ZERO button

Use this button to set the minute to “00” when it is between “55” to “59” or “01” to “05”.

(12) AUX button

Use this button to choose which to listen to, the radio or the external audio source connected to the AUX-IN. If the external source is chosen, the AUX display appears on the LCD.

(13) AUX-IN jack

Use this jack to connect an external audio source. Pull off rubber cap and plug the stereo mini-plug of the external audio device into this jack. Be sure that jack is closed with the rubber cap when not in use.

Playing the radio

1. Turn the ignition key to the ACC or ON position, and then press the power button (1) to turn on the radio.
2. Select the band FM or Am with the band button.
3. Select the station with the preset button or the tuning button, and adjust the volume with the volume button.
4. To turn off the radio, press the power button.

Selecting a station-auto select

Press and hold the turn button (▲) for two seconds or one to start seeking stations in the higher frequencies direction. Press and hold the button (▼) for two seconds or more to start seeking stations in the lower frequencies direction. The radio will stop seeking when it finds an audible station and start playing.

Selecting a station-manual select

The selection can be done manually. Press the tune (▲) button to seek stations with higher frequencies. Press the tune (▼) button to seek stations with lower frequencies.



Presetting stations

1. Select the band (FM or AM) and the station you want to preset.
2. To set the selected station to a preset button, choose the button to be set and then press and hold the button for three seconds or more. The number of the preset button chosen appears on the LCD.
3. For more stations, repeat the steps (1) and (2) above.
 - If the preset button on which a station has been set to is pressed and held for two seconds or more, the preset information will be modified.
 - If the stored information is erased during battery replacement on the vehicle, set the stations again to the preset buttons.
 - Each preset button can store information on one FM station and one AM station.

AUTO storing

Press the AST button for two seconds or more while playing the radio. The radio starts seeking the audible stations obtained into memory, and assign each preset button (1 to 6) a station.

Note: The previous station setting stored in memory will be overwritten. If the arrangement of the preset buttons to the corresponding stations is not desirable, try the "Presetting stations" described above.

AUX audio connection

- Connect a portable audio player and listen to your favorite music.
- Plug a patch cord (without resistor) into the headphone jack of the audio player.
- Plug a stereo mini plug (3.5 mm) into the AUX-IN jack on the radio.
- To listen to the audio player, press the AUX button. (The AUX display appears and the frequency display is changed to the clock display.)
- To return to the radio, press the AUX button again.
- When connecting, adjust the sound volume level of the audio player so that it is same as that of the radio.
- Adjust the sound volume of the audio player by using the volume control buttons on the radio.
- Do not connect a device with a larger output compared with a portable audio player.

Setting the clock time

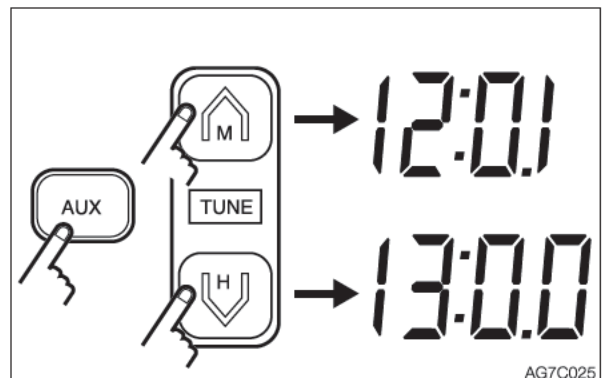

- Be sure that the time is displayed on the LCD. If not, press the AUX button to display the time.
- Use the tune (M) button to set the minute. Use the tune (H) button to set the hour.
- To set the minute digits to "00" when they are from "55" to "59" or from "01" to "05", press the ZERO button.



Resetting the radio

If there are any problems, such as the abnormal display of frequency or failure of selection, reset the radio by pressing the power button and the ZERO button together.

Note: That the memory containing the clock setting and the channel setting is cleared after reset.

SPECIFICATIONS

Power source:	12/24 VDC (negative ground)
Power consumption:	2 A
Maximum output power:	16 W + 16 W (4Ω) (at DC 28.8 V input) 5W+5W (4Ω) (at DC 14.4 V input)
Rated output power:	14 W + 14 W (10% distortion, 4Ω) (at DC 28.8V input) 3.8 W + 3.8 W (10% distortion, 4Ω) (at DC 14.4V input)
Dimensions:.....	178 (W) x 50 (H) x 92 (D) mm (without projections)
Receiving frequency:	MW (AM) 530 to 1602 kHz (EU, Asia), 1710 kHz (North, Central and South America) FM 87.9 to 108 MHz
Practical sensitivity:.....	MW (AM) 32 dB or less (S/N 20 dB) FM 12 dB or less (S/N 30 dB)
S/N ratio:.....	MW (AM) 40 dB or more FM 60 dB or more
AUX IN:	Stereo mini jack (3.5 mm); rated input, 90 mV

Note: Specifications and dimensions may be changed without notice.



AUXILIARY HYDRAULIC LINES

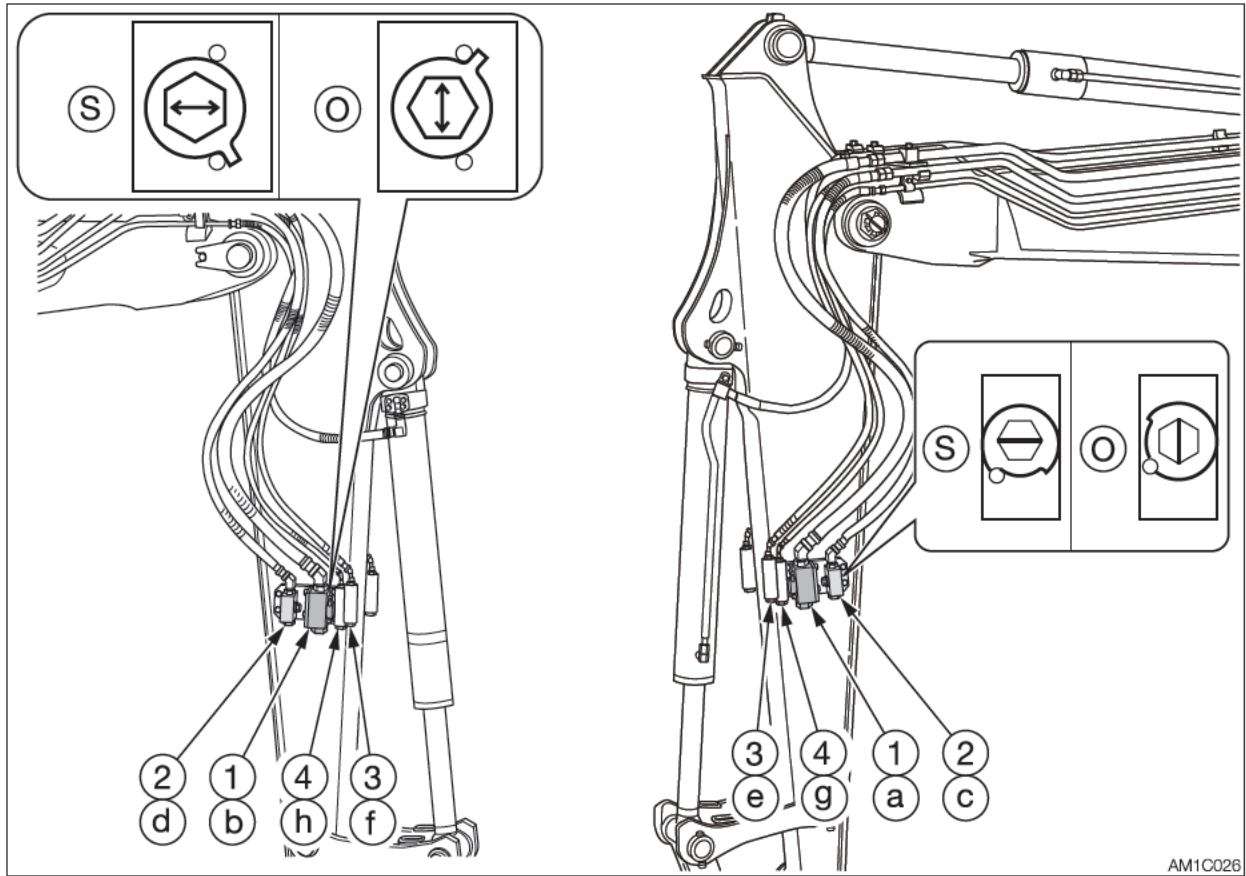

AM1C026

WARNING

Oil may spurt out if pipes disconnected before releasing the pressure in the hydraulic system.

- Immediately after the engine is stopped and while the safety lock lever is still in the unlock position, turn the starter switch to ON and press each auxiliary hydraulic switch several times to release the pressure from the auxiliary hydraulic circuit.
- Press the air breather button to relieve the tank pressure.
- When disconnecting hoses, stand to the side and loosen them slowly to gradually release the internal pressure before removing.

These lines deliver the hydraulic oil necessary for operating a hydraulic breaker, crusher or other attachments.

- (1).....First auxiliary hydraulic lines
- (2).....Second auxiliary hydraulic lines
- (3).....Third auxiliary hydraulic lines
- (4).....Fourth auxiliary hydraulic lines

Stop valve
(S) : Closed
(O) : Open



Connecting the hydraulic circuits

To connect the attachment hydraulic lines, observe the following procedures:

1. Release the pressure remaining in the lines, and then close the stop valve. Refer to “Releasing the residual pressure” on page 2-48.
2. Remove the plugs.
3. Connect the attachment hydraulic lines to ports (a/c) and (b/d). When installing a hydraulic breaker, connect the supply circuit to the port (a) and the return circuit to port (b).
4. Open the stop valves. When installing a hydraulic breaker, open the selector valve (1). Refer to “Selector valve” on page 2-49.
5. When connecting is complete, purge air from the hydraulic lines.
 - a. Start the engine and run it at a low idle speed with no load for 10 minutes.
 - b. With the engine running in low idle, operate the auxiliary hydraulic switches repeatedly (approx. 10 times) to purge air from the hydraulic lines.
 - c. Stop the engine and wait for at least 5 minutes until bubbles escape from the hydraulic oil in the tank.

IMPORTANT: Follow the procedures for purging air as instructed by the attachment manufacturer, if applicable.

6. Check for oil leaks.

Disconnecting the hydraulic circuits

1. Release the pressure remaining in the lines, and then close the stop valve. Refer to “Releasing the residual pressure” on page 2-48.
2. Disconnect the lines from the ports (a/c) and (b/d).
3. Install the plugs.

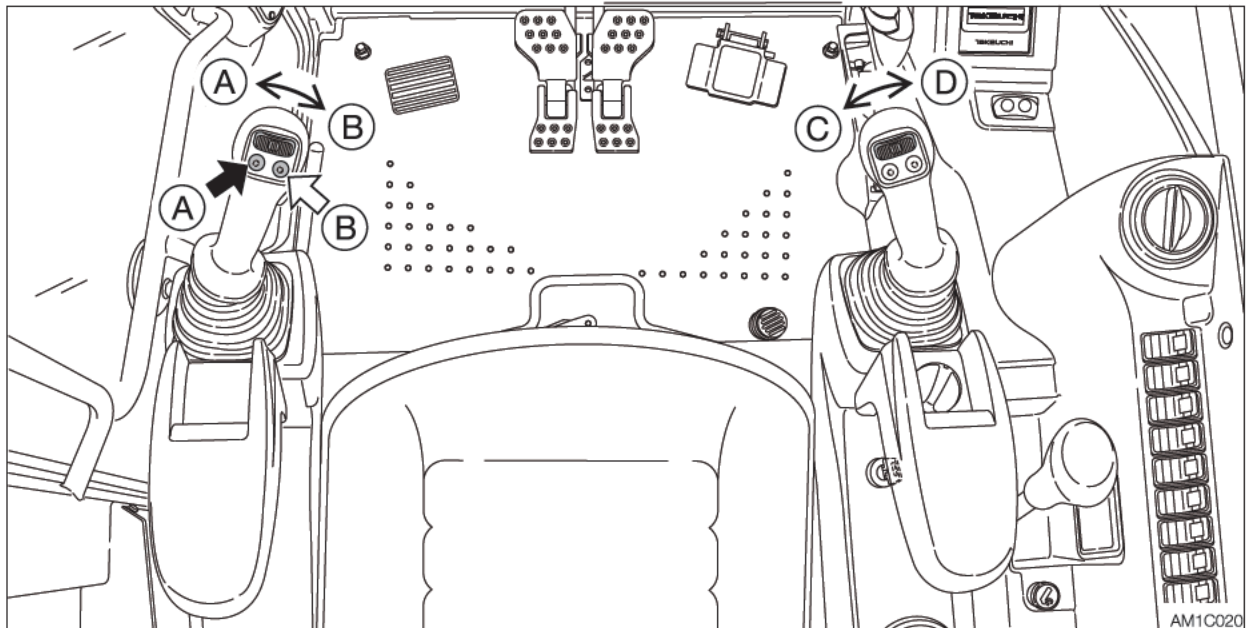

Operating

Press those buttons to control the flow of the oil in the first/second auxiliary hydraulic lines.

- (A).....Hydraulic oil flows to left auxiliary line (a).
- (B)Hydraulic oil flows to right auxiliary line (b).
- (C)Hydraulic oil flows to left auxiliary line (c).
- (D)Hydraulic oil flows to right auxiliary line (d).

Releasing the residual pressure

After the auxiliary hydraulic circuits have been used, pressure remains in the circuits. This is called the residual pressure. Release this residual pressure before disconnecting the lines.

Perform the residual pressure releasing within 30 minutes after the engine stopping.

1. Park the machine on a flat, rigid and safe ground.
2. Stop the engine.
3. Lower the safety lock lever to the unlocked position.
4. Turn the starter switch to the ON position.
5. Press the auxiliary hydraulic switches several times to release the residual pressure in the auxiliary hydraulic circuitry.



Selector valve

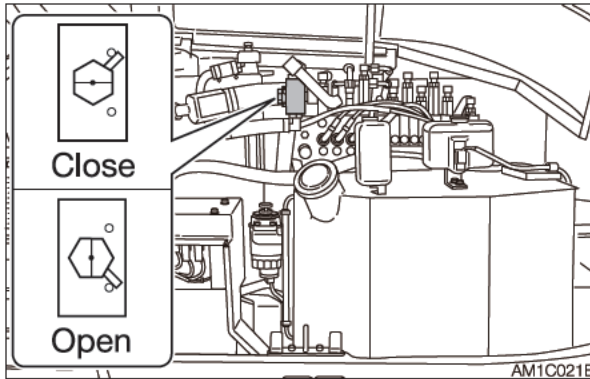

Open When using a hydraulic breaker (1-way flow)
 Closed..... When using a reversible attachment (2-way flow)
 Change the direction of the hydraulic oil flow by opening or closing the selector valve (1) inside the fuel lid.
 Use the high-flow only in the 2-way flow. If it is used in the one-way flow, the brake may overheat.

Third auxiliary hydraulic switch and button

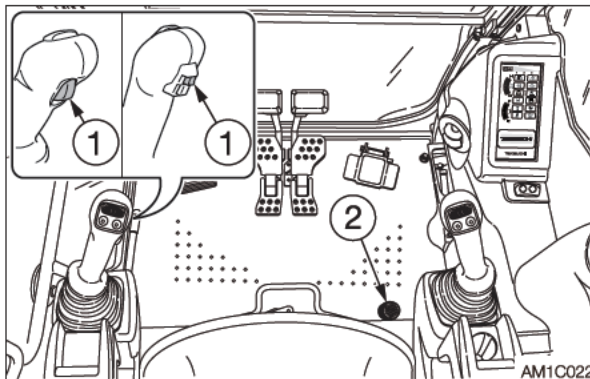

The third auxiliary hydraulic lines are normally used to control the “quick attachment” installed to connect/disconnect the bucket. When the safety lock lever is released after the engine is started, hydraulic oil flows into the pipe (e). This allows the pressure in the (e) side to increase and to prevent the pin inserted on the bucket from coming out. If the pressure in the (e) side drops, the alert that the bucket may come out is indicated by the warning lamp and the alarm. For a safety reason, the bucket can be disconnected only

when the button (1) and the switch (2) are pressed at the same time. When they are pressed, the hydraulic oil flows into the line (f) to increase the pressure there. As the result, the pin on the bucket comes out and the bucket is removed from the machine.

Third auxiliary hydraulic warning lamp

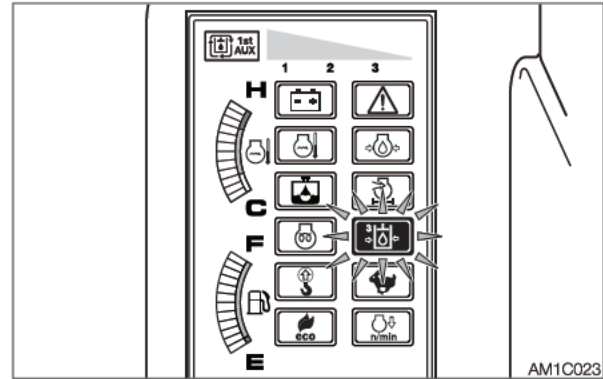

This lamp illuminates and an alarm sounds when the third auxiliary hydraulic pressure drops abnormally, when the safety lock lever is fully lowered to the unlocked position while the engine is running.



Auxiliary 2/4 select button

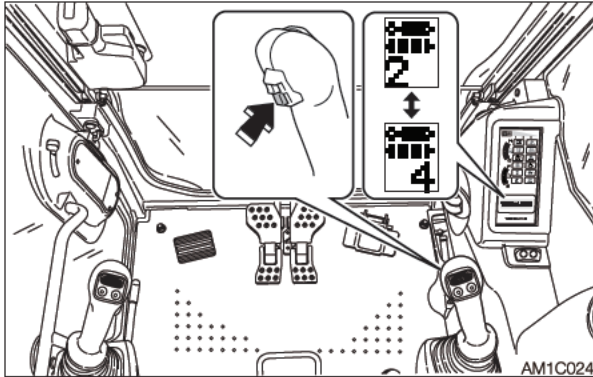

This button is used to change from the second auxiliary operation to the fourth auxiliary operation.

Pressing this button displays the second auxiliary on the LCD to indicate that the second auxiliary operation is enabled.

Pressing this button again displays the auxiliary 4th on the LCD to indicate that the auxiliary 4th operation is enabled.

The actual operation is performed with the auxiliary 2nd/4th switch (slider switch). Refer to “Auxiliary 2nd/4th switch” on page 2-26.



OPERATING THE MACHINE WITH AN ACCUMULATOR

WARNING

Be sure to handle the high-pressure nitrogen gas enclosed in the accumulator with care. If handled incorrectly, it could explode and cause serious injury. Strictly observe the following precautions:

- Do not disassemble.
- Do not allow flame near or throw it into a fire.
- Do not drill, weld or fuse.
- Do not subject it to physical shock such as hitting, rolling or dropping.
- Before disposing of the unit, the sealed gas must be drained. Contact a **Takeuchi service agent for help.**

For a machine with an accumulator, the residual pressure in the auxiliary hydraulic circuit or the working equipment circuit can be released even after the engine is stopped.

Releasing residual pressure

Residual pressure refers to the pressure that remains in the hydraulic circuit after the operation. Release the residual pressure as necessary by using the following steps. Perform the residual pressure releasing within 10 minutes after the engine stopping.

1. Return the throttle controller to idle the engine at low speed.
2. Lower the bucket and dozer blade to the ground.
3. Check that the safety lock lever is in the released position.
4. Stop the engine.
5. Turn the starter switch to the ON position.

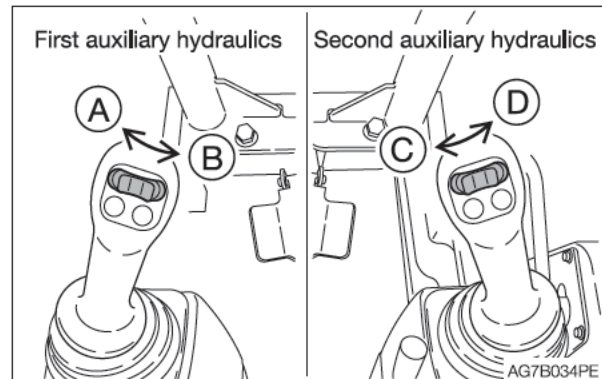

6. Move or press the auxiliary hydraulic switches several times to release the residual pressure in the circuitry.
7. Move all the control levers and pedals several times in all directions to release the pressure from the working equipment circuitry.
8. Raise the safety lock lever to engage the lock.

Lowering the boom when the engine has stopped

Perform this operation within 10 minutes after the engine stopping.

1. Sit at the operator's seat.
2. Turn the starter switch to the ON position.
3. Lower the safety lock lever to the unlock position
4. Slowly push the operating lever forward to lower the boom.



LOAD SAFETY DEVICE

The load safety devices include an emergency shut-off valve and an overload warning device. The emergency shut-off valve prevents the boom or arm from falling. The overload warning device sounds an alarm when an excessive load is detected.

Emergency shut-off valve

The emergency shut-off valve prevents the boom or arm from falling rapidly.

WARNING

If the emergency shut-off valve is activated and the boom or arm falls, immediately move away from the load being lifted and go to a safe location.

Boom

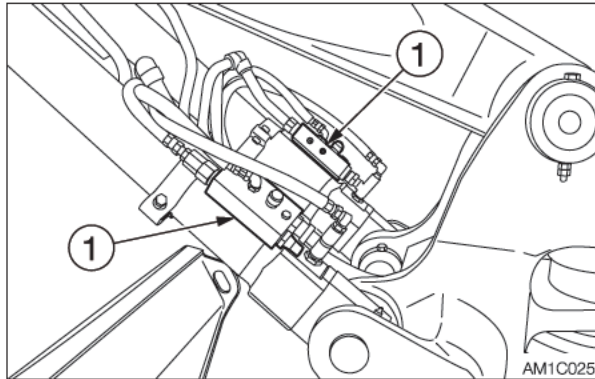

2-Piece boom

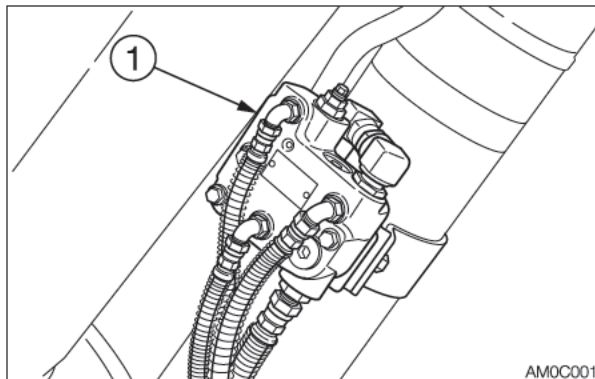

Second boom

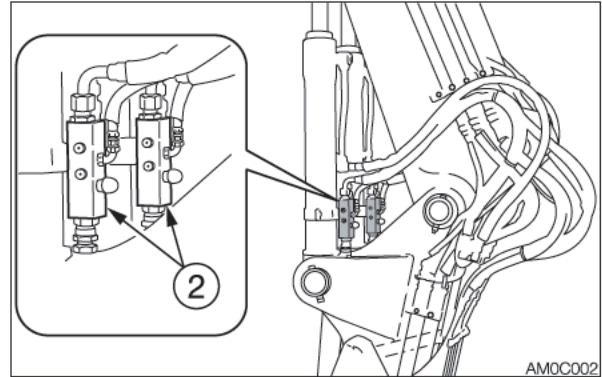

Arm (option)

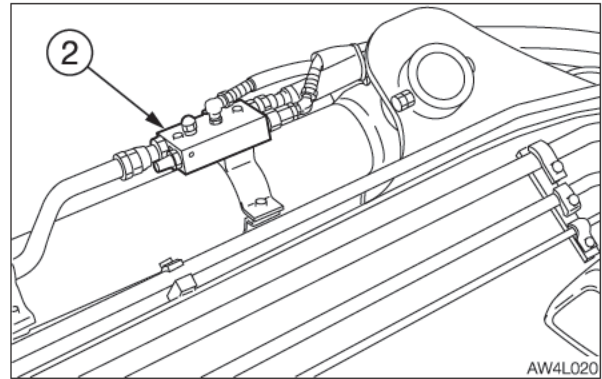

If the emergency shut-off valve (1) or (2) is activated, immediately set the operating levers to the neutral position. Do not move the operating lever to the boom or arm lowering side. Ask your sales or service dealer for repair.

If the engine can be started without problems, the boom or arm can be lowered with the operating lever. Slowly lower the boom or arm while ensuring safety.

Procedure 1 (when engine can be started)

Perform this operation within 10 minutes after the engine stopping.

1. Sit at the operator's seat.
2. Turn the starter switch to the ON position.
3. Lower the safety lock lever to the unlock position
4. Slowly push the operating lever forward to lower the boom.



Procedure 2 (when engine cannot be started)

This operation is dangerous and requires experience. Ask your sales or service dealer for it.

⚠ WARNING

- Stop the engine and allow the machine to cool down before performing maintenance.
 - The engine and the hydraulic system and many other parts of the machine are hot immediately after the engine is stopped. Touching these parts will cause burns.
 - The hydraulic oil is also hot and under high pressure immediately after the engine is stopped. Be careful when loosening the caps or plugs. Working on the machine under these conditions could result in burns or injuries due to the hot oil spurting out.
- Keep away from the working area when the hoe attachment is lowered. You may be hit by dirt falling out of the bucket or the hoe attachment as it drops.
- Stand in a position away from danger of lowering boom and loosen the hose nut. Otherwise, you could be hit by the boom.
- Do not loosen or remove the hoses not located in the specified places. Oil may spurt out if wrongly handled.

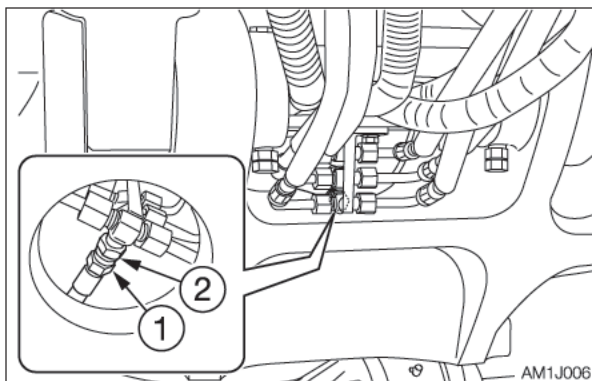

1. Place a pan under the hose to catch the waste oil.
2. Hold the hose fitting (1) with a wrench and loosen the hose nut (2) with another

wrench.

3. The oil in the boom cylinder is drained and the hoe attachment is lowered.
4. After the hoe attachment is lowered to the ground, check the safety and stability of the machine.
5. Hold the hose fitting (1) with a wrench and tighten the hose nut (2) with another wrench.
 - Tightening torque: 24.5 to 29.4 N·m (18.1 to 21.7 ft·lb.)

OVERLOAD WARNING DEVICE

If a weight greater than the lifting capacity is applied or lifted, the overload warning device is activated and the horn sounds. (When the overload warning switch is turned on.)

⚠ WARNING

If the overload is not removed after the overload warning horn is sounded, the machine may tip over or the emergency shut-off valve may be activated. If the horn starts sounding, stop operating the machine and lighten the load.

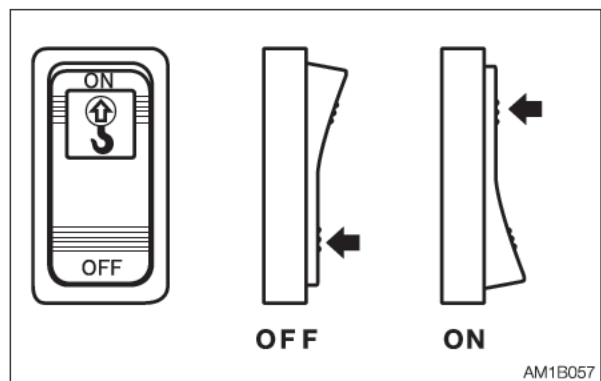

Overload warning switch (1)

OFFOff

ONOn

If the emergency shut-off valve is activated, the overload warning horn stops.

(This is because the pressure sensor can no longer detect hydraulic pressure.)



FUEL SUPPLY PUMP

This device automatically supplies fuel to the fuel tank and stops automatically when the fuel tank is full.



DANGER

Do not use the fuel supply pump for gasoline or hydraulic oil. Doing so could result in explosion or damage.

Only use the fuel supply pump for diesel fuel.

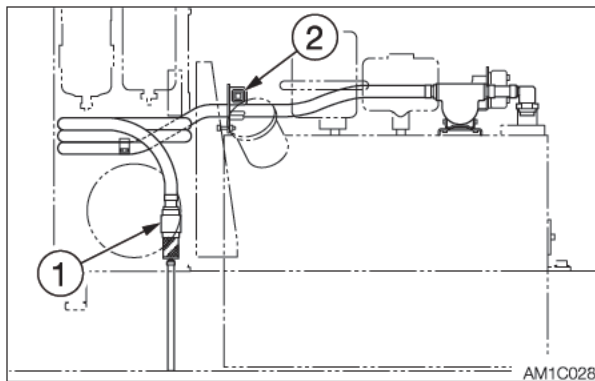

1. Open the side cover.
2. Insert the pump's nozzle (1) in the fuel supply tank.
3. Press the switch (2).
The pump stops automatically once the fuel tank is full.
4. Turn off the switch.
5. Store the nozzle.

OPERATION



BEFORE STARTING

OPERATION

GETTING ON OR OFF THE MACHINE

WARNING

- Do not jump on or down from the machine. Never attempt to get on or off the moving machine.
- When getting on or off the cab, first fully open the door to the locked position and check that it does not move.

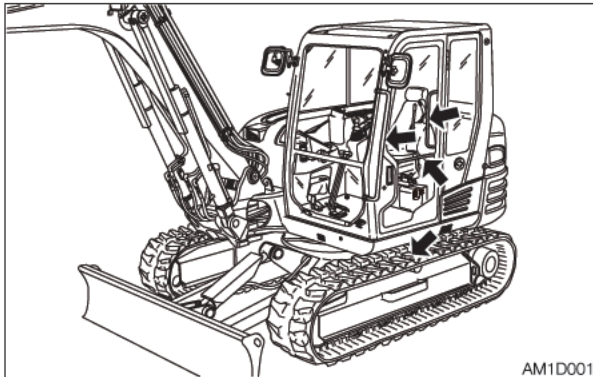

- Climb up/down the steps holding the handrail to support your weight in a three point secure stance (hand and feet).
- Never use the safety lock lever or control levers as hand holds.

WALK-AROUND INSPECTION

Perform the walk-around inspections once a day before starting the engine for the first time that day.

Refer to “MAINTENANCE, Walk-around inspection”, on pages 5-14 and 5-15.

DAILY INSPECTION

Perform the daily inspections once a day before starting the engine for the first time. Refer to “MAINTENANCE, Daily inspection”, on pages 5-16 to 5-21.



STARTING AND STOPPING THE ENGINE

BEFORE STARTING THE ENGINE

1. Adjust the seat for a comfortable operating position.
2. Fasten the seat belt.

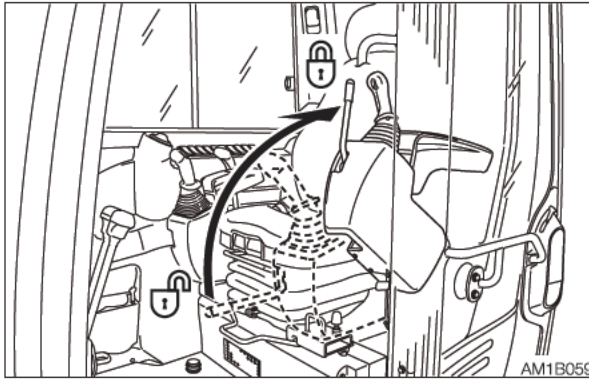

3. Check that the safety lock lever is in the locked position.

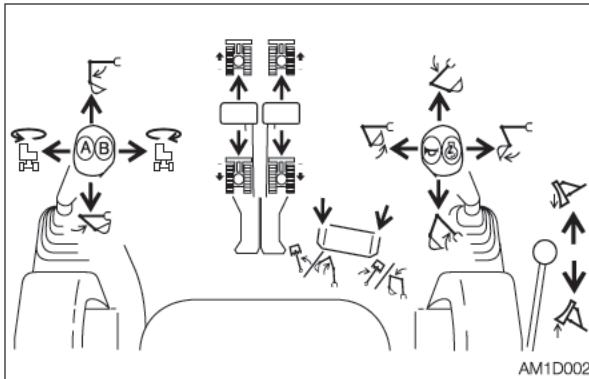

4. Check that all levers and pedals are in the neutral position.

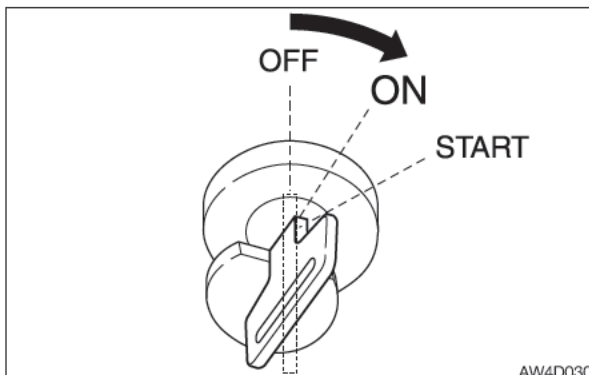

5. Insert the key into the starter switch, turn it to the ON position, then perform the following inspections:

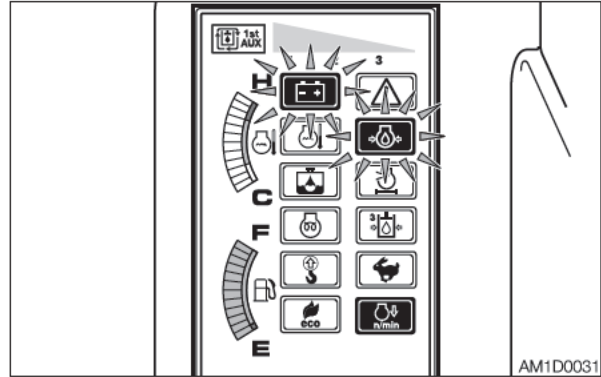

- All warning lamps flash and an alarm is sounded for two seconds. The meters also start functioning. After two seconds, the deceleration lamp (7) stops flashing and remains lit, while the battery charge warning lamp (1) and engine oil pressure warning lamp (2) remain flashing. (If the auxiliary 3rd is selected, it is also flashing.) The other lamps go out.
- Turn the light switch to check that the boom light, front light, side lights, tail lamps and meter light turn on.
- Check the fuel level.

If a lamp does not light or the alarm is not sounded, the bulb may be burnt out or a wire may be damaged. Ask a Takeuchi service agent for repair.



STARTING THE ENGINE

WARNING

- Clear all personnel from the work area.
- Sound the horn to warn people around the machine.

IMPORTANT: Do not run the starter motor for more than 15 consecutive seconds. If the engine fails to start, wait for 30 seconds, and then try again to start the engine.

Normal starting

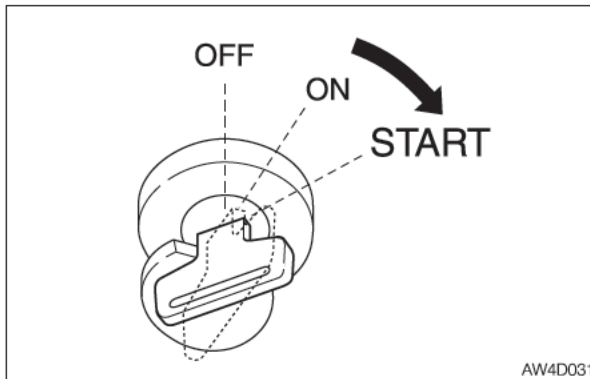

1. Turn the starter key to the START position and start the engine.
2. Once the engine starts, release the key. The key automatically returns to the ON position.
3. Check that the warning lamps are off. For safety reasons, it is designed that the deceleration function is activated to set the engine revolutions to low idling whenever the engine is started. Cancel the deceleration mode by pressing the deceleration button as necessary.
4. Warm up the engine. Refer to “Warming up the engine” on page 3-5.
5. After the completion of the warming up, press the deceleration button to cancel the deceleration mode.

Starting in cold climates

WARNING

Never use starting fluid on this engine, as the starting fluid could cause an explosion.

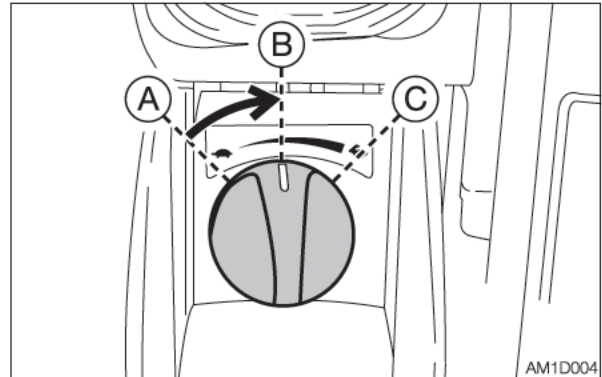

1. Turn the throttle controller to the middle position.

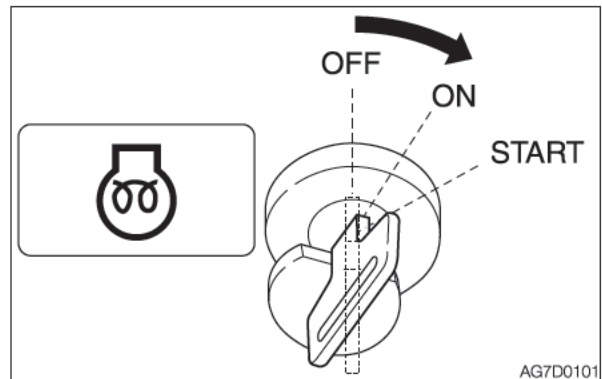

2. Turn the starter key to the ON position, and confirm that the glow lamp is lit. (The glow lamp stays lit when the coolant temperature is -10°C (14F°) for 15 seconds (TB285) or 2 seconds (TB290).)
3. After the glow lamp goes out, press the deceleration button (to cancel the deceleration mode), and then turn the key to the START position to start the engine.
4. Once the engine starts, release the key. The key automatically returns to the ON position.
5. Check that the warning lamps are off.
6. Return the throttle controller to the original position and warm up the engine. Refer to “Warming up the engine”.



WARMING UP THE ENGINE

IMPORTANT: Avoid racing the engine until it has warmed up.

Do not warm up the engine for a long time (20 minutes or more). When idling is required, occasionally place a load or run the engine at medium speed.

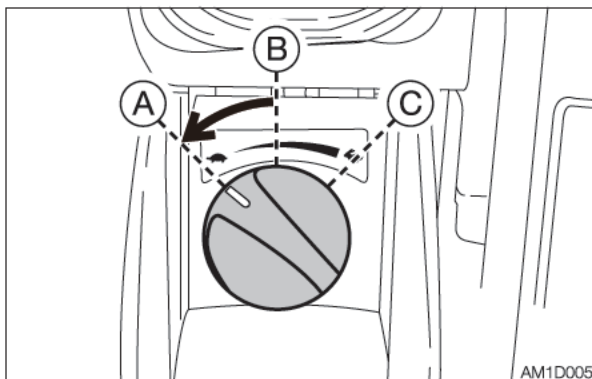

1. Return the throttle controller, and then run at a low idle with no load for 5 minutes.

STOPPING THE ENGINE

IMPORTANT: Do not stop the engine suddenly when operating with heavy loads or at the maximum speed. Doing so may cause the engine to overheat or seize. Never stop running the engine suddenly except in emergency.

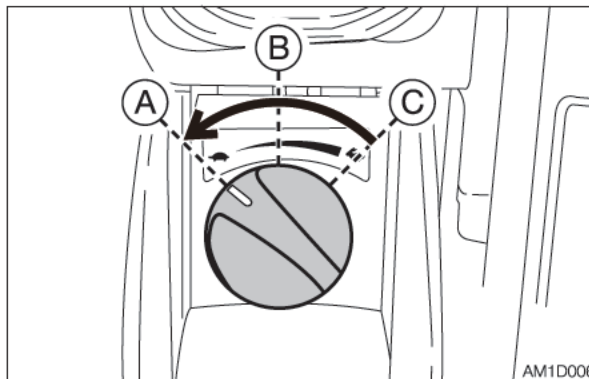

1. Return the throttle controller.
2. Idle the engine for about 5 minutes to gradually let it cool.

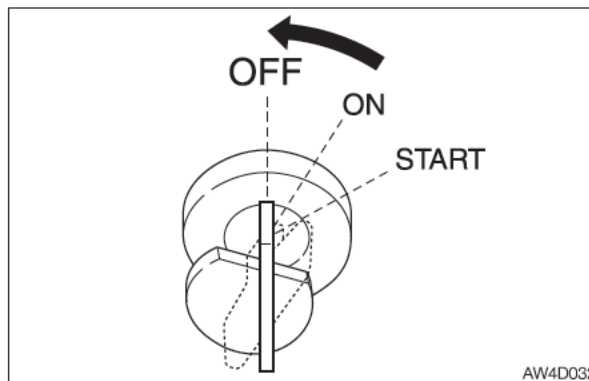

3. Turn the starter key to the OFF position to stop the engine.



OPERATING THE MACHINE

LEVER PATTERN (ISO PATTERN)

⚠ WARNING

- Before starting operation, carefully check which lever pattern you are going to use.
- It is described using the ISO pattern in this manual.

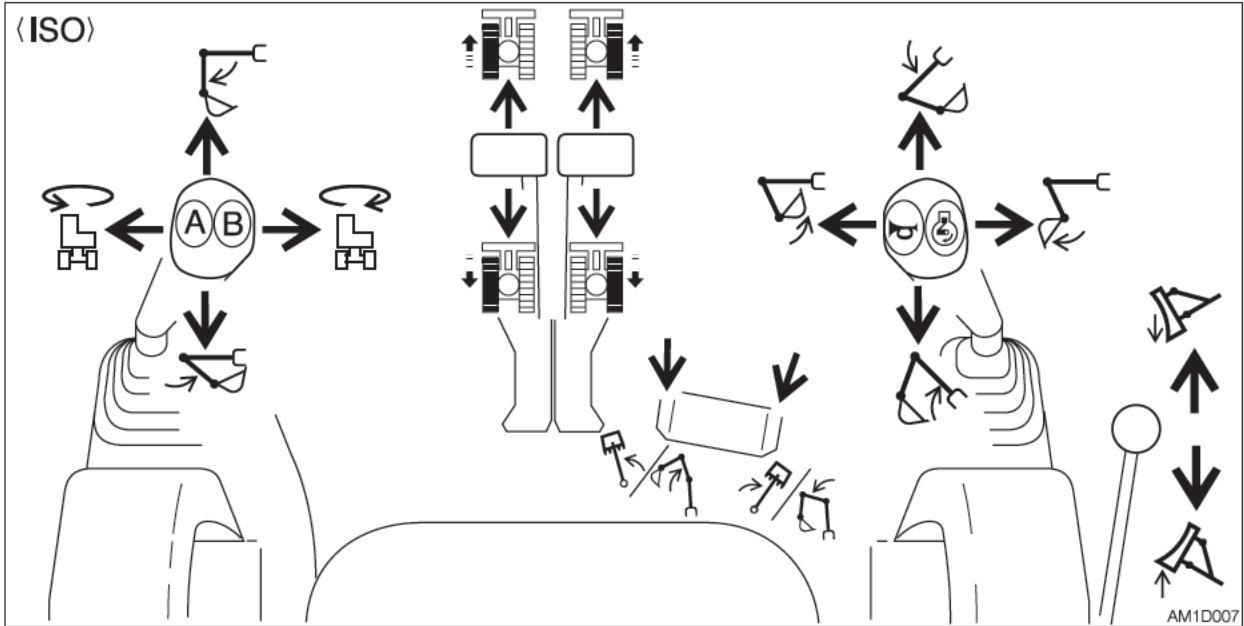

	Left crawler forward		Right crawler forward
	Left crawler reverse		Right crawler reverse
	Arm out		Boom lower
	Arm in		Boom raise
	Upperstructure slew left		Bucket load
	Upperstructure slew right		Bucket dump
	Boom swing left Second boom raise (2-piece boom)		Dozer blade lower
	Boom swing right Second boom lower (2-piece boom)		Dozer blade raise



LEVER PATTERN (JCB PATTERN)

⚠ WARNING

- Before starting operation, carefully check which lever pattern you are going to use.
- It is described using the ISO pattern in this manual.

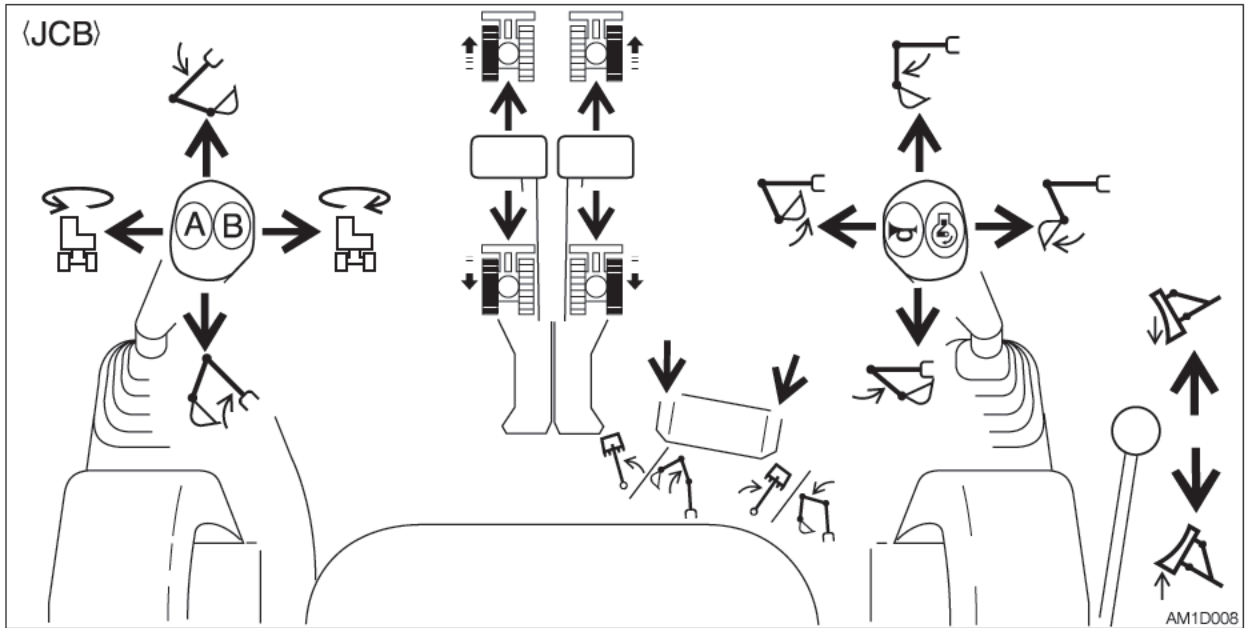

	Left crawler forward		Right crawler forward
	Left crawler reverse		Right crawler reverse
	Boom lower		Arm out
	Boom raise		Arm in
	Upperstructure slew left		Bucket load
	Upperstructure slew right		Bucket dump
	Boom swing left Second boom raise (2-piece boom)		Dozer blade lower
	Boom swing right Second boom lower (2-piece boom)		Dozer blade raise



WARMING UP THE MACHINE (HYDRAULIC OIL)

WARNING

Operating the working equipment without warming up the machine (hydraulic oil) is dangerous, as the working equipment cannot respond to controls quickly or may move in unexpected ways, and the safety devices may not operate properly. Be sure to sufficiently warm up the machine.

IMPORTANT: Do not operate the levers too quickly when the hydraulic oil temperature is below 20°C (68°F). The proper hydraulic oil temperature during operation is 50 to 80°C (122 to 176°F). If operations must be performed at lower temperatures, heat up the hydraulic oil to at least 20°C (68°F).

Normal warm-up

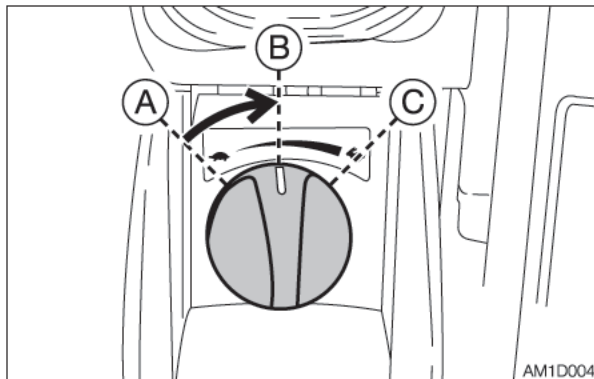

1. Turn the throttle controller to the middle position, and then run the engine at medium speed for about five minutes with no load.

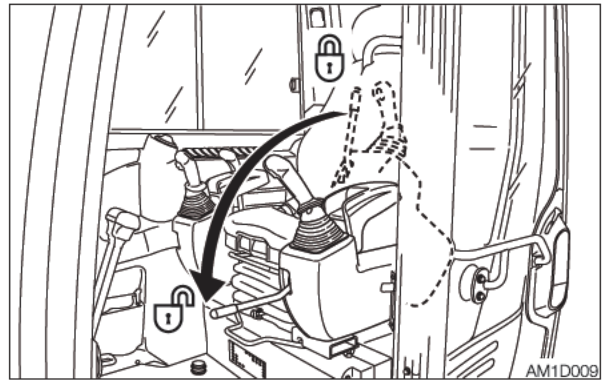

2. Fully lower the safety lock lever to disengage the lock and lift the bucket from the ground.

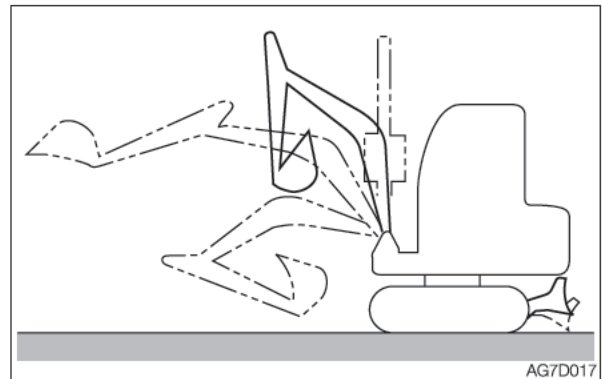

3. Extend and retract each of the cylinders slowly several times with no load.

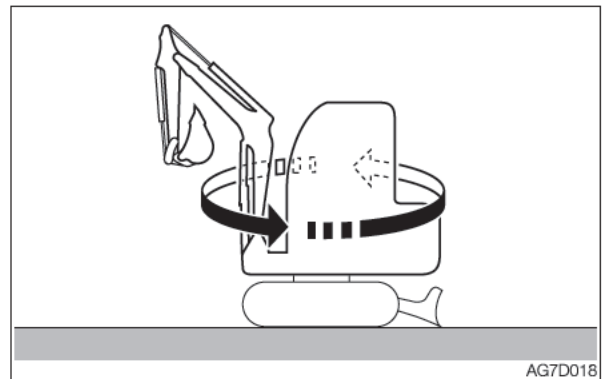

4. Slew slowly to the left and the right several times.

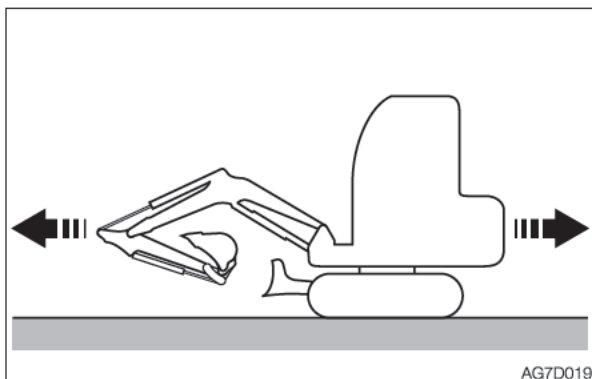

5. Travel slowly forward and in reverse several times.

Warm-up in cold climates

1. Perform the normal warm-up procedure.

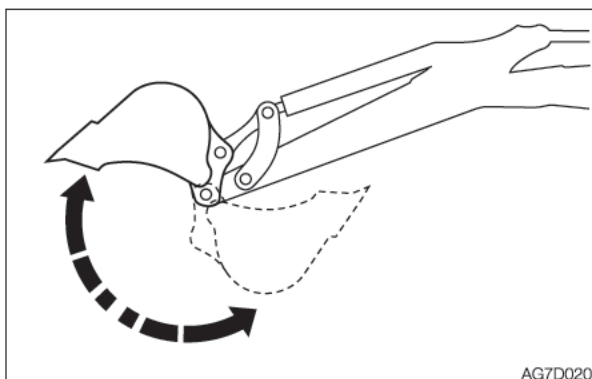

2. Set the bucket cylinder at the stroke end and keep it there.
Do not keep this condition for more than 30 seconds.
3. Repeat Step 2 until the bucket operating speed becomes normal.

INSPECTION AFTER WARM-UP

After warming up the engine and machine (hydraulic oil), perform the checks and inspections described below, and repair if necessary.

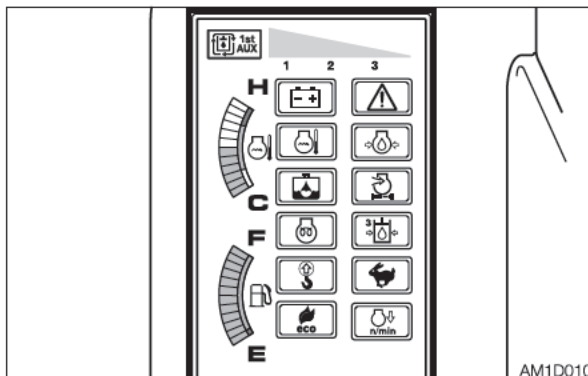

1. Check that the warning lamps and meters are as follows:
 - Are all warning lamps off?
 - Is the LED on water temperature gauge seen within the green range?
2. Check that there are no irregularities in the exhaust color, sound and vibrations.

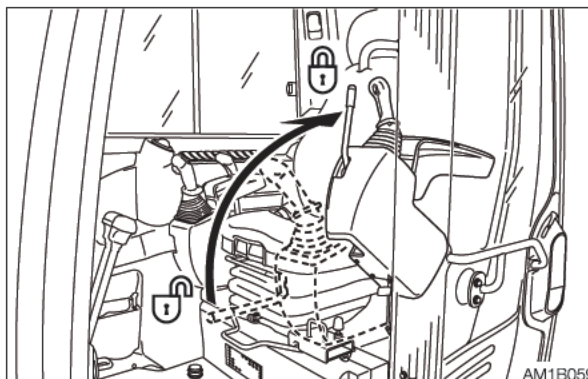

3. Raise the safety lock lever to the locked position, and then check that the operating and travel levers are locked.



OPERATING THE TRAVEL LEVERS

WARNING

- Never allow anyone to enter the machine's slewing radius and path.
- Signal your intention to move by sounding the horn.
- There is a blind spot in the rear of the machine. Before traveling in reverse, as necessary, swing the cab around in reverse to check that the area is safe and clear.

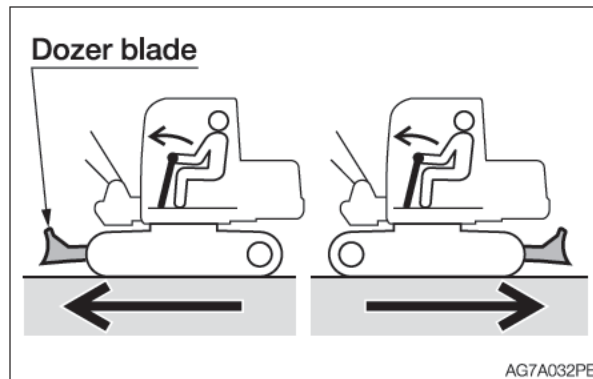

- Before operating the travel levers/pedals, make sure that the dozer blade is to the front of the operator's seat. Remember that when the dozer blade is to the rear of the operator's seat, the travel levers/pedals must be operated in the reverse direction from when it is to the front.
- Clear all obstacles from the path of the machine.

Moving the machine forward and backward

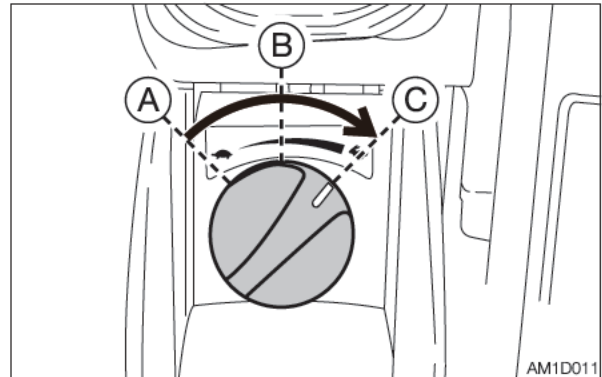

1. Turn the throttle controller and increase the engine speed.

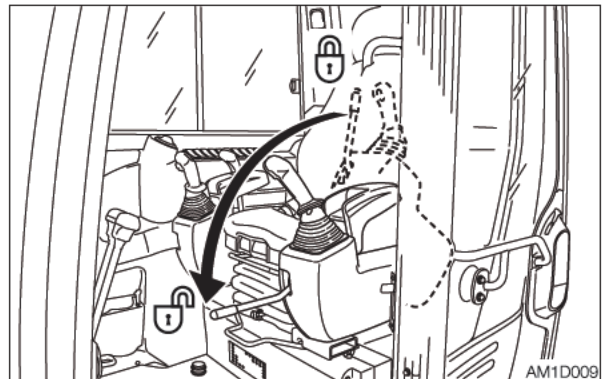

2. Fully lower the safety lock lever to disengage the lock.

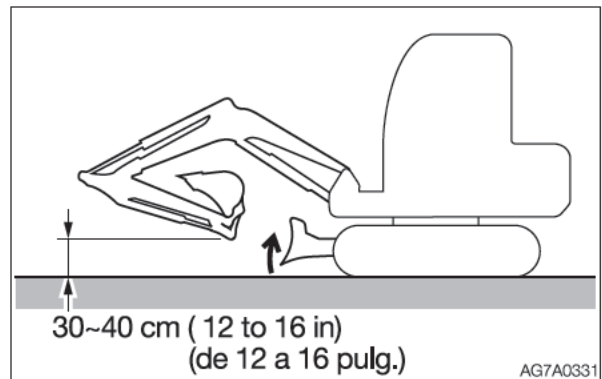

3. Fold the hoe attachment and lower it 30 to 40 cm (12 to 16 in.) above the ground.
4. Lift the dozer blade.
5. Operate the left and right travel levers as below.



OPERATION OPERATING THE MACHINE

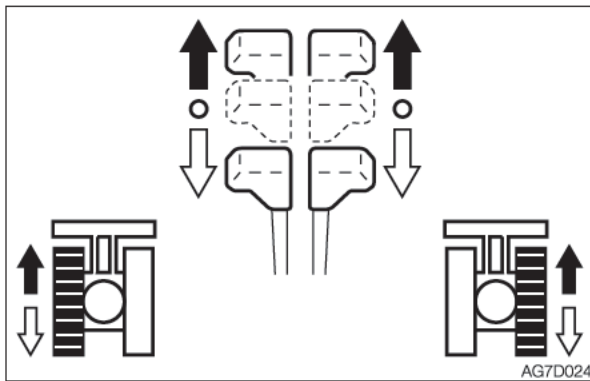

When the dozer blade is in front of the operator's seat:

- ➔ To move forward:
Tilt the levers forward.
- ⇨ To move backward:
Tilt the levers backward.

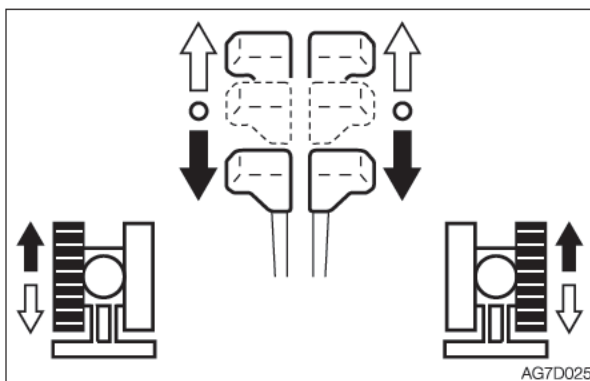

When the dozer blade is behind the operator's seat:

- ➔ To move forward:
Tilt the levers backward.
- ⇨ To move backward:
Tilt the levers forward.

Traveling in 2nd (High) speed

WARNING

When a load greater than a set value is applied during traveling in 2nd (high) speed, the speed will automatically slow down to 1st (low) speed. When the load becomes lighter, the speed will increase and return to 2nd (high) speed. It should be noted that the travel speed changes depending on the load condition (for machines with the automatic travel shift-down system).

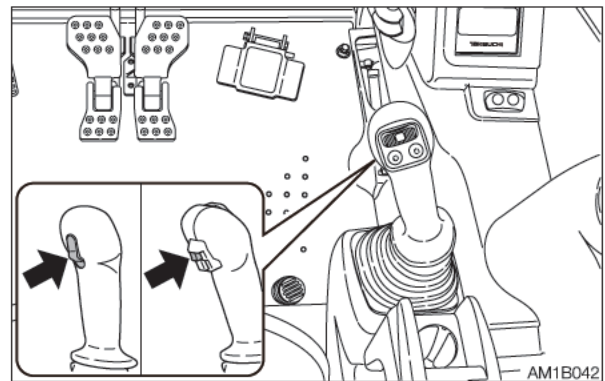

Press the travel speed switch to set to the 2nd (high) speed, and press it again to return to the 1st (low) speed.



Pivot turn

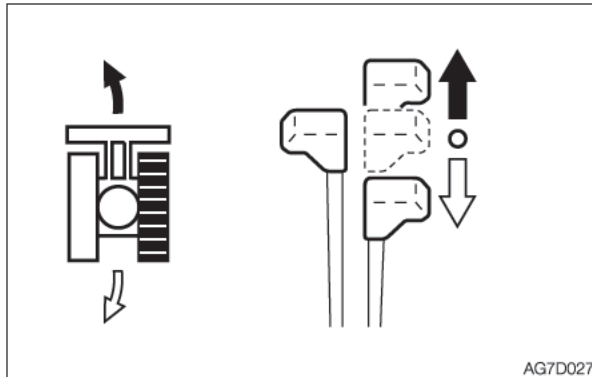

Turning to the left when stopped:

- ➔ To turn forward to the left:
Tilt the right lever forward.
- ⇨ To turn backward to the left:
Tilt the right lever backward.

To turn to the right, operate the left lever in the same way as for the right lever.

Spin turn

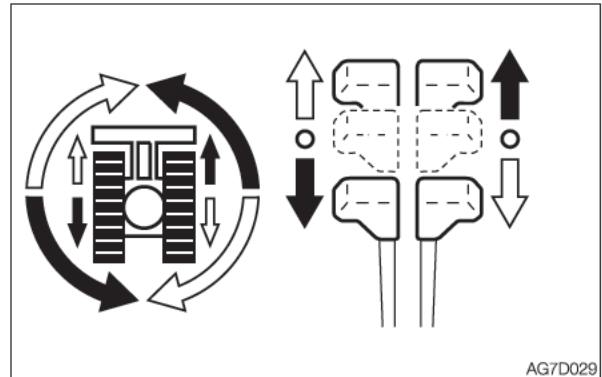

- ➔ To spin left:
Tilt the left lever backward and the right lever forward.
- ⇨ To spin right:
Tilt the right lever backward and the left lever forward.

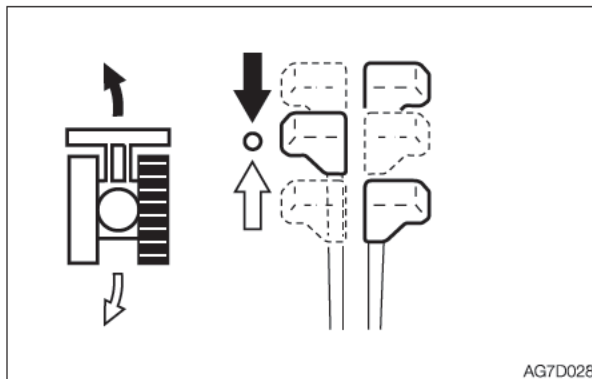

Turning to the left while traveling:

- ➔ To turn left while traveling forward:
Set the left lever to neutral.
- ⇨ To turn left while traveling backward:
Set the left lever to neutral.

To turn to the right while traveling, operate the right lever in the same way as for the left lever.



STOPPING TRAVEL

WARNING

- Park the machine on a flat, rigid and safe ground. Set the parking brake. If you must park on a slope, chock the tracks to block the machine.
- If any control is accidentally touched when the safety lock lever is not locked, the machine may suddenly move and cause serious injury or death.

CAUTION

Never stop running the machine suddenly except in emergency. Stop in good time, if possible.

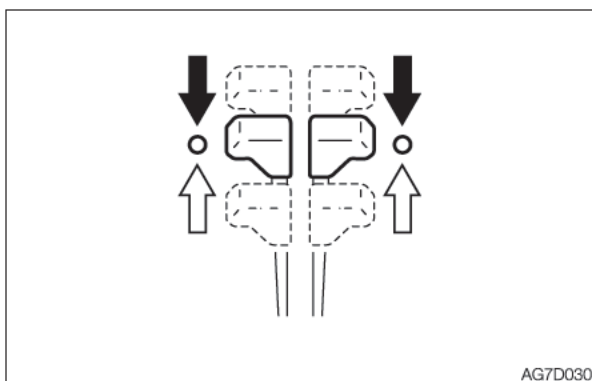

1. Set the left and right travel levers slowly to the neutral position. The machine stops.



OPERATING THE WORKING EQUIPMENT

! WARNING

- Before starting operation, carefully check which lever pattern you are going to use.
- It is described using the ISO pattern in this manual.

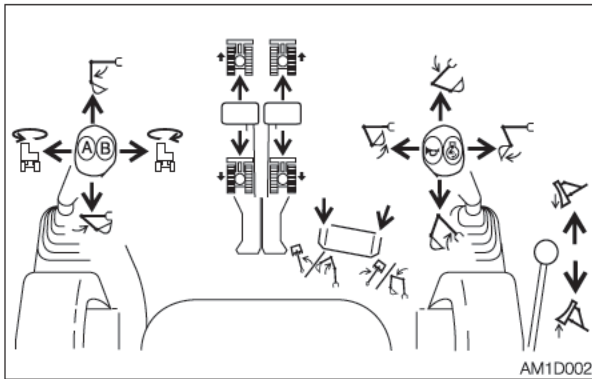

Use the right operating lever to operate the boom and bucket.

Use the left operating lever to operate the arm and slewing.

Return the operating levers to the neutral position to stop the hoe attachments.

1. Lower the safety lock lever to the unlocked position.
2. Set the pedal cover to the unlocked position.

Slewing

! WARNING

Check the surrounding area for safety before slewing.

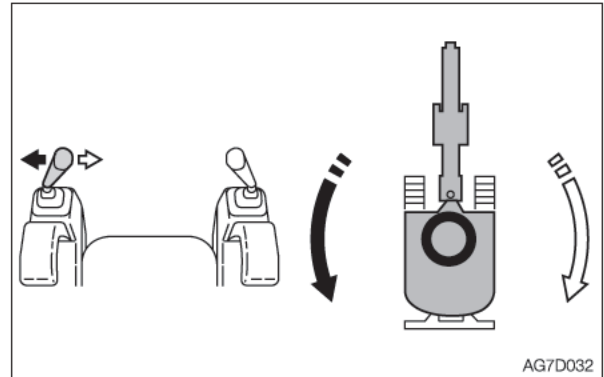

- ➔ Upperstructure slew left:
Tilt the left operating lever to the left.
- ⇨ Upperstructure slew right:
Tilt the left operating lever to the right.

Operating the boom

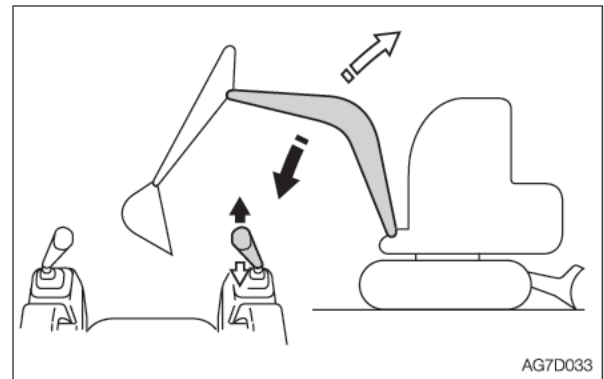

- ➔ Boom lower:
Tilt the right operating lever forward.
- ⇨ Boom raise:
Tilt the right operating lever backward.



OPERATION OPERATING THE MACHINE

Operating the arm

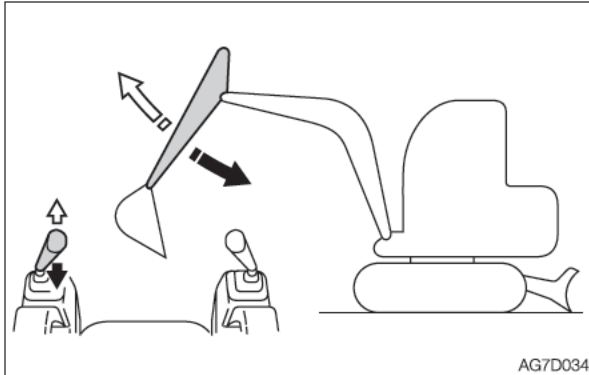

AG7D034

- ➔ Arm in:
Tilt the left operating lever backward.
- ⇨ Arm out:
Tilt the left operating lever forward.

Operating the bucket

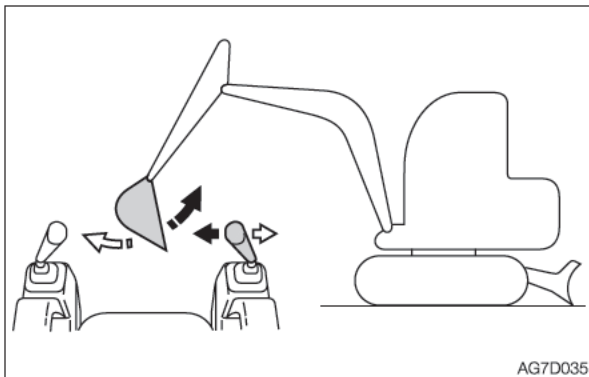

AG7D035

- ➔ Bucket load:
Tilt the right operating lever to the left.
- ⇨ Bucket dump:
Tilt the right operating lever to the right.

Operating the boom swing

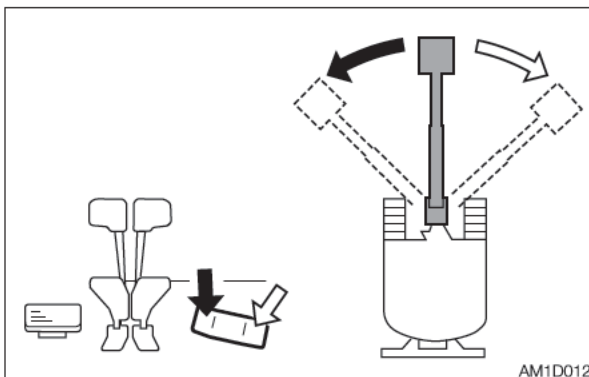

AM1D012

- ➔ Boom swing left:
Step on the left side of the pedal.
- ⇨ Boom swing right:
Step on the right side of the pedal.

Operating the second boom

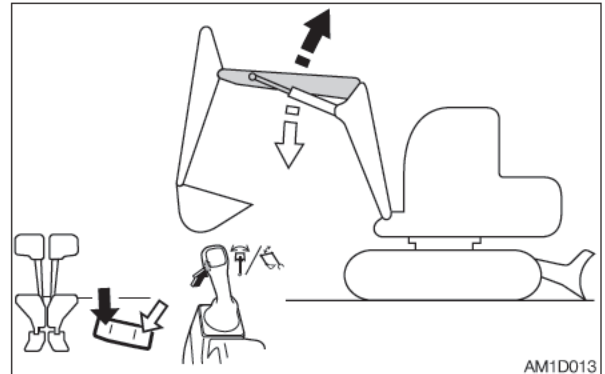

AM1D013

- ➔ Second boom raise:
Step on the left side of the pedal.
- ⇨ Second boom lower:
Step on the right side of the pedal.

Operating the dozer blade

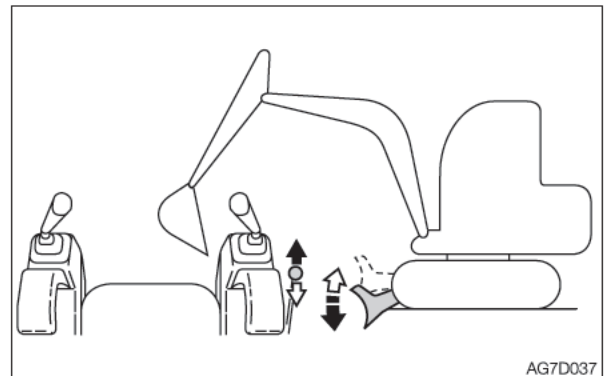

AG7D037

- ➔ Dozer blade lower:
Tilt the lever forward.
- ⇨ Dozer blade raise:
Tilt the lever backward.



OPERATING PROCEDURES

PROHIBITED OPERATIONS

WARNING

- Do not operate on bedrock (hard or soft).
- Do not slew while traveling. If you must operate the hoe attachment while traveling, operate at speeds slow enough so you have complete control at all times.

Do not perform demolition or leveling using slew force

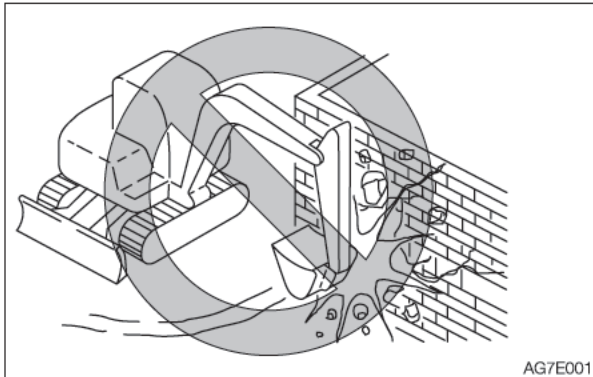

Do not demolish walls or level ground using slew force. Also, do not dig the bucket teeth into the ground during slewing. Doing so will damage the hoe attachment.

Do not dig while traveling

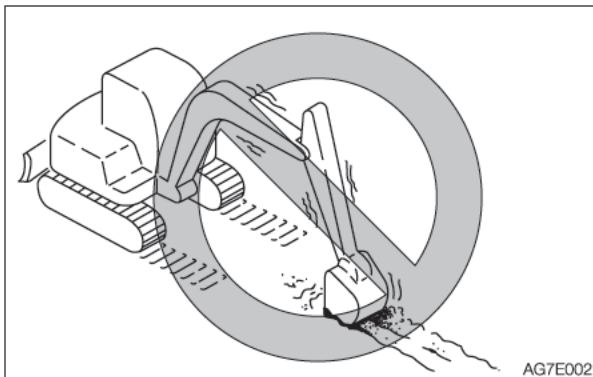

Do not dig the bucket into the ground and use the traveling force to dig.

Be gentle when using the hydraulic cylinder

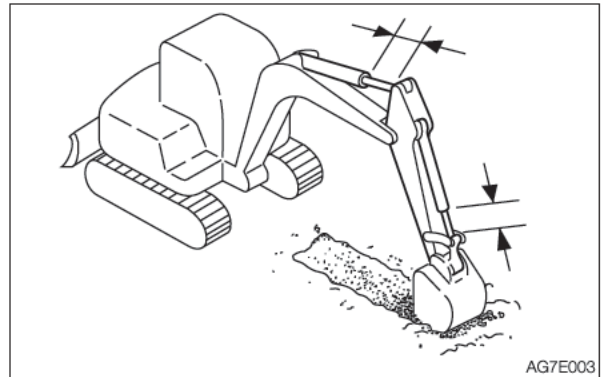

Do not extend the hydraulic cylinders to the stroke ends. Operate them with leeway.

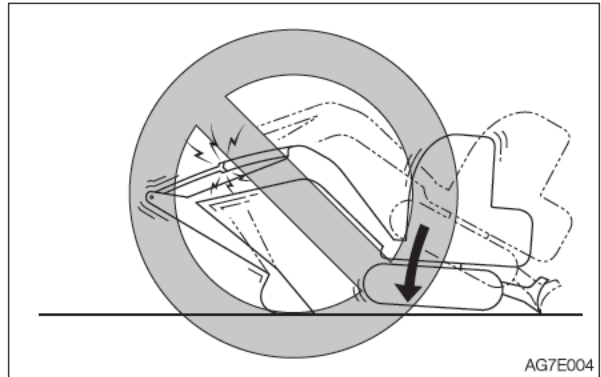

Do not support the machine body with the hoe attachment when the body is lowering with the arm cylinder fully extended. Doing so concentrates the load on the arm cylinder and could damage the arm cylinder.



Do not drive piles with the bucket or dig by banging the bucket

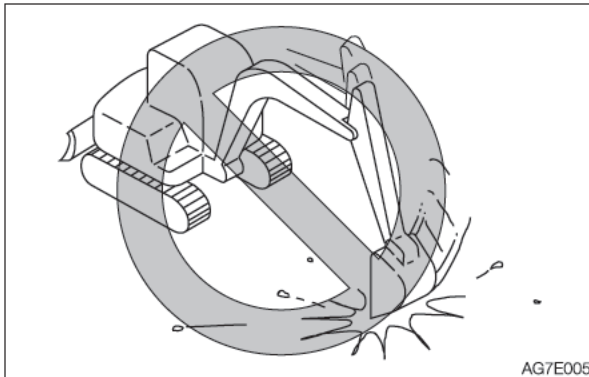

Doing so will shorten the service life of the hoe attachment. Use the hydraulic force to dig.

Do not perform operations using the machine's dropping force

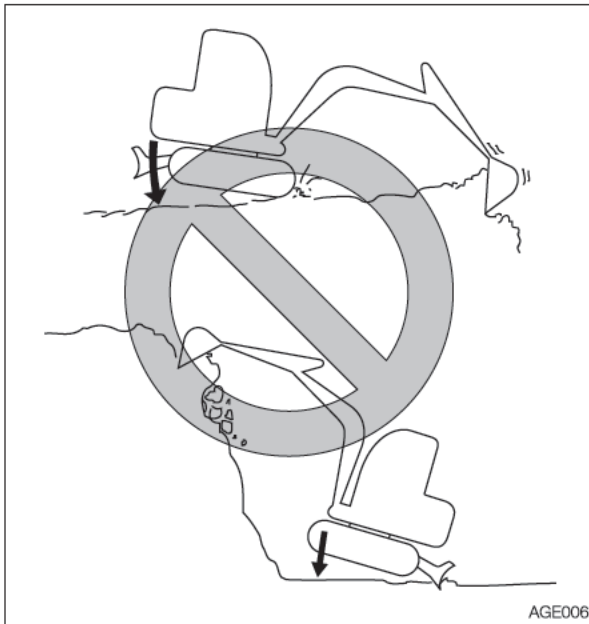

Putting excessive strain on the machine will shorten its service life. When digging, use the hydraulic force of the cylinders and the shallow and long strokes.

Digging bedrock

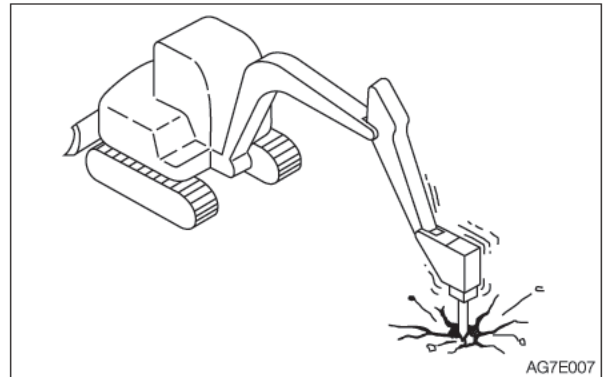

For hard base rock, break the rock up into small pieces with a breaker, etc., before digging. This prevents damage to the machine and is thus more economical in the end.

Caution on exposing the dozer blade to shocks

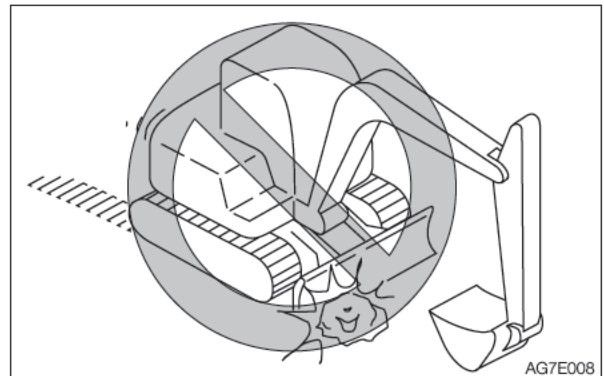

Hitting the dozer blade against rocks, etc., could damage the dozer blade or the blade cylinder.



Caution on folding the hoe attachment

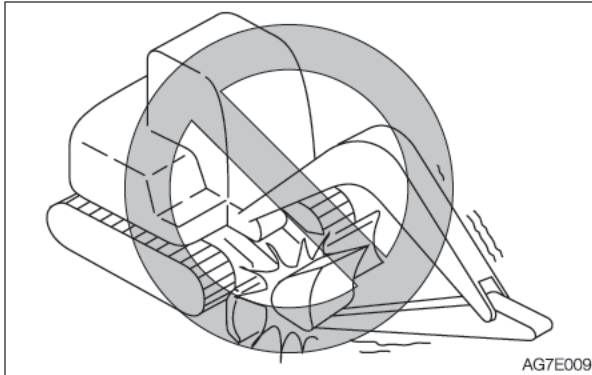

Be careful not to let the bucket hit the dozer blade when the hoe attachment is being folded.

Do not use the dozer blade as an outrigger

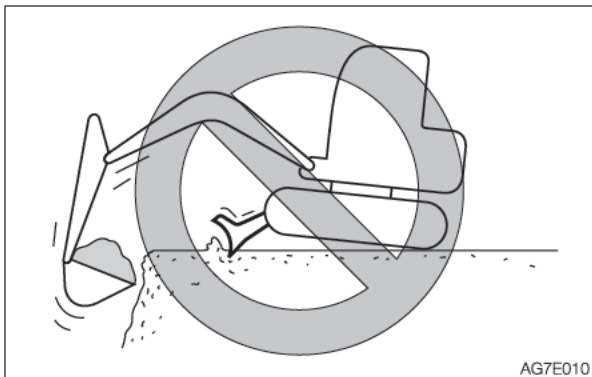

Pay attention to the dozer blade when digging

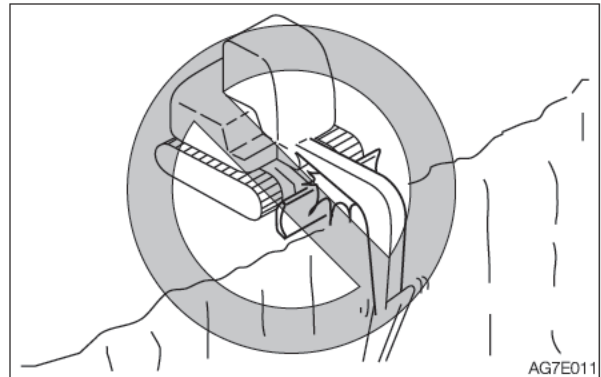

When digging deeply with the dozer blade positioned at the front, be careful that the boom cylinder and bucket do not hit the dozer blade. Operate with the dozer blade at the rear whenever possible.

Caution on digging down with the dozer blade

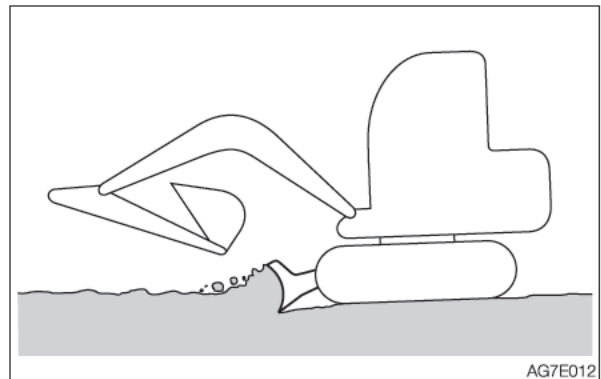

This dozer blade is designed for simple earth pushing. Do not dig down deeply with the dozer blade. Doing so could damage the dozer blade and undercarriage.



CAUTIONS ON OPERATING

CAUTIONS ON TRAVELING

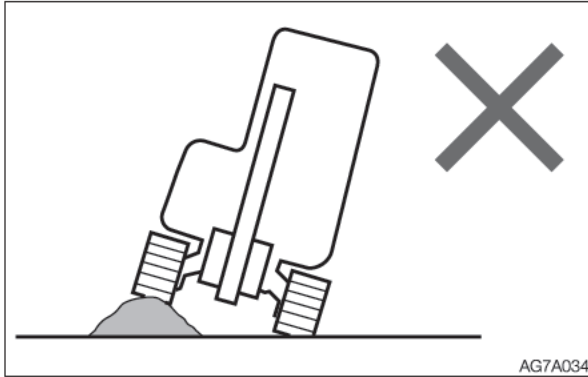

Traveling over obstacles (rocks, stumps, etc.) may put a great load on the machine body and may cause damage to it. Avoid crossing over obstacles whenever possible. If you must do so, keep the hoe attachment near the ground, travel at a low speed, and go over the obstacle at the center of the crawler.

Caution on traveling in 2nd (High) speed

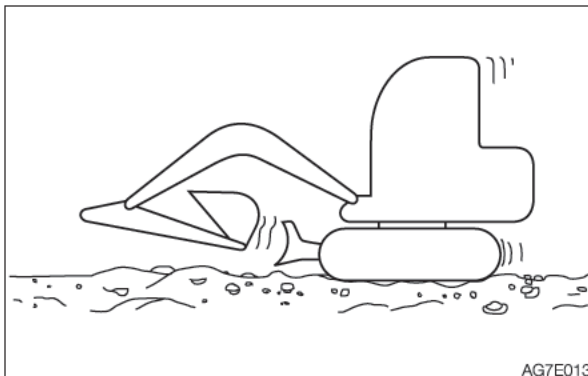

- On uneven ground, maintain the low speed and avoid starting, stopping or changing directions abruptly.
- When a load greater than a set value is applied during traveling in 2nd (high) speed, the speed will automatically slow down to 1st (low) speed. When the load becomes lighter, the speed will increase and return to 2nd (high) speed. It should be noted that the travel speed changes depending on the load condition.
- When traveling in 2nd speed, do so with the dozer blade at the front.

Caution on using machine in water

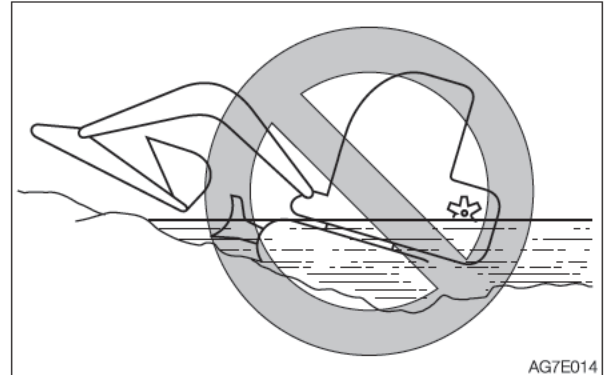

If the rear of the machine is submerged in water as shown in the figure above, it causes the radiator fan to turn in water, resulting in damage to the fan. The rear of the machine must not be submerged.

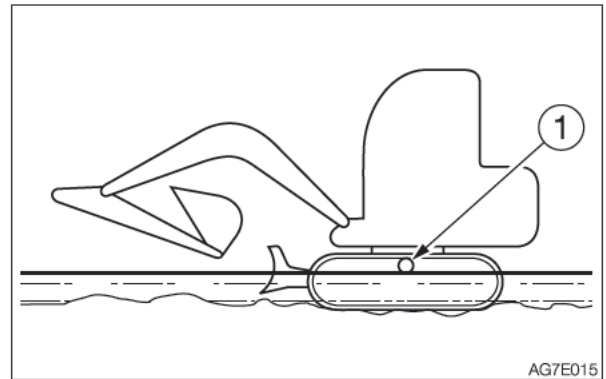

- Allowable water depth
Use the machine in water only when the water is up to the bottom of the carrier roller (1).
- For those parts used in water for a long time, apply enough grease until the old grease is expelled.
- Never submerge the slew bearing or main body in water or sand. If submerged, contact a Takeuchi service agent for inspection.



CAUTIONS ON TRAVELING ON SLOPES

WARNING

- Never travel on slopes that are too steep for the machine to maintain its stability. (maximum gradeability: 35°, lateral tipping angle: 15°) Note that in reality, the machine's stability becomes lower than the above values depending on the working condition.
- When traveling on slopes, lower the bucket to a height of 20 to 30 cm (8 to 12 in.) above the ground. When climbing a steep slope, extend the hoe attachment to the front. In emergencies, lower the bucket to the ground and stop the machine.
- When traveling on slopes or grades, drive slowly in 1st (low) speed.
- When climbing a hill, keep the operator's seat facing the hillside. When descending a hill, keep the operator's seat facing the downhill direction. In either case, travel must be done while paying attention to the ground in front of the machine.
- Do not descend slopes in reverse.

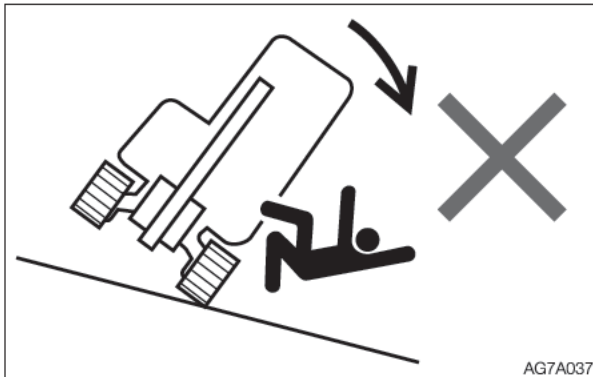

- Do not change directions on slopes or traverse slopes. First return to a flat surface, and then take an alternative path.

- The machine may slip sideways even on a slight slope if they are covered with grass or dead leaves, or when traveling on a wet metal plate or frozen surfaces. Do not allow the machine to position sideways to slopes.

Traveling posture on slopes Climbing slopes

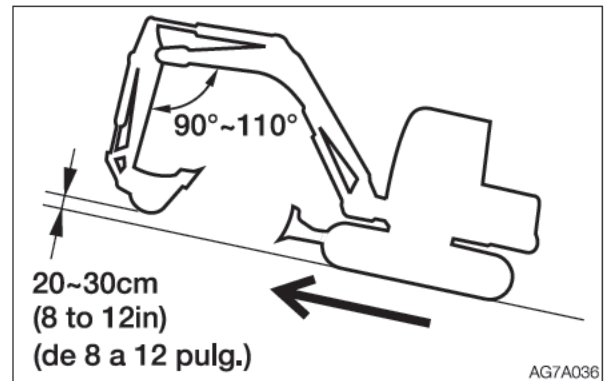

When climbing slopes of 15° or more, maintain the machine posture as shown in the figure above.

Descending slopes

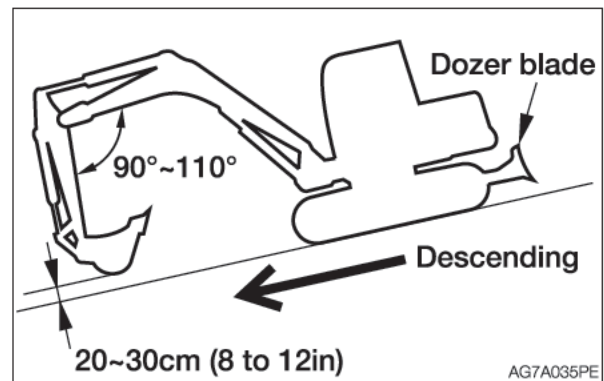

When descending slopes of 15° or more, slow down the engine speed and maintain the machine posture as shown in the figure above.



Braking when descending slopes

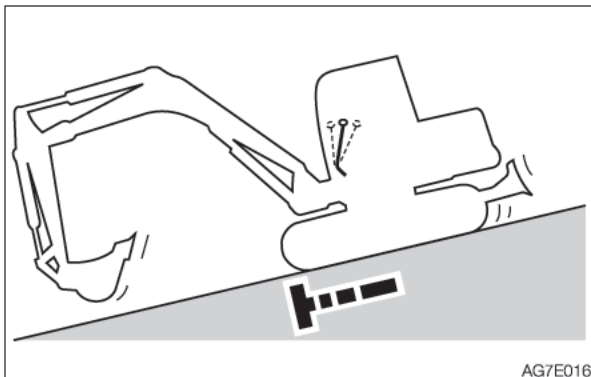

When descending slopes, the brakes are applied automatically once the travel levers are returned to the neutral position.

If the crawler slips

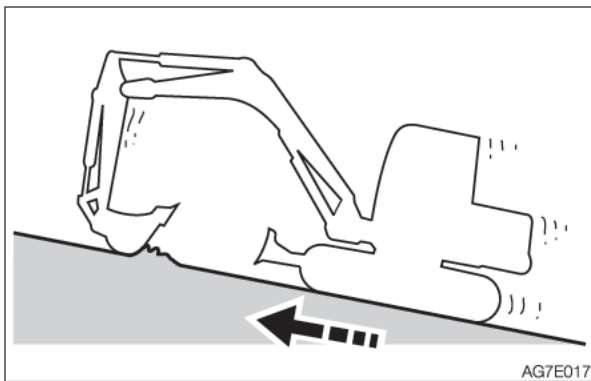

If the crawler slips while climbing a slope and impossible to travel, use the pulling force of the arm to climb the slope.

If the engine stops

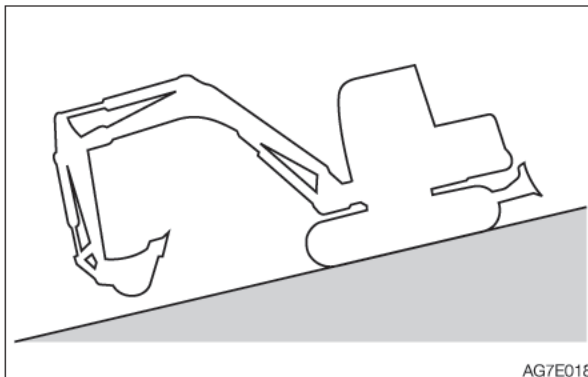

If the engine stops when descending a slope, set the travel levers to the neutral position, stop the machine, then start the engine.

Do not open the door while traveling on slopes

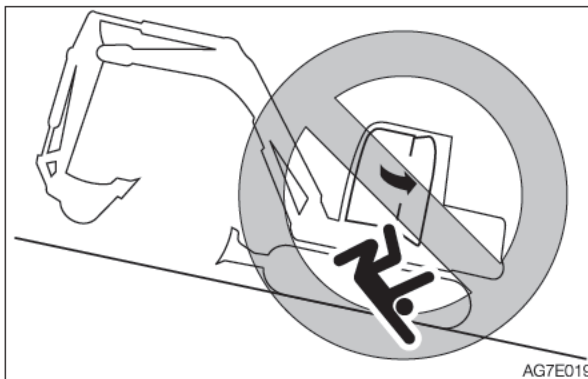

Opening the door while traveling on slopes is dangerous, as the force required to open and close the door changes abruptly. Always keep the door closed when traveling on slopes.



GETTING OUT OF MUD

If the machine gets stuck in mud, use the procedure below to get it out.

If one crawler is stuck



1. Swing the bucket to the side of the crawler being stuck.
2. Set the arm and boom to an angle of 90 to 110°.
3. Press the bottom of the bucket (not the teeth) against the ground.
4. Place a plank or the like under the lifted crawler.
5. Lift the bucket and slowly move the machine out of the mud.

If both crawlers are stuck

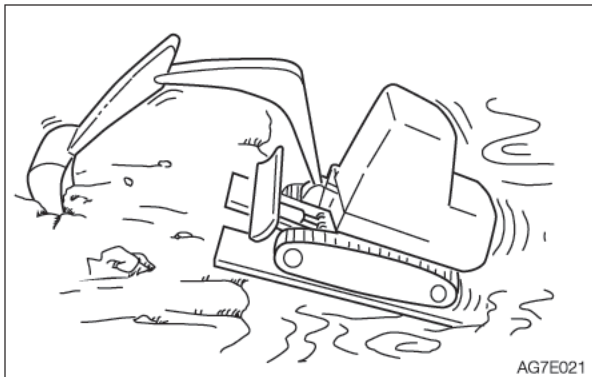

1. Perform the steps 1 to 4 above for both crawlers.
2. Dig the bucket into the ground in front of the machine.
3. Pull with the arm while traveling forward to slowly move the machine out.

OPERATIONS POSSIBLE WITH THIS MACHINE

Excavating

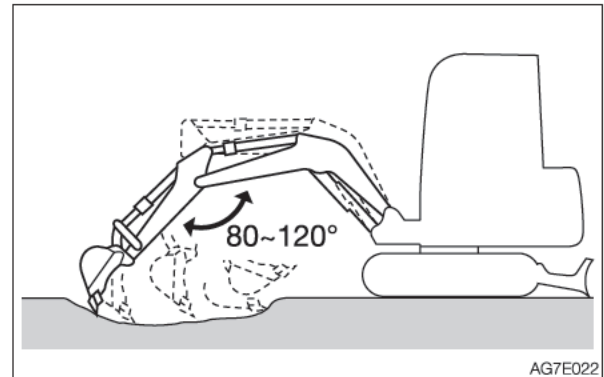

1. Set the dozer blade on the side opposite to the side you want to dig on.
2. Use the arm and bucket and dig with shallow, long strokes. The maximum digging force can be obtained when the boom and arm angle is 80 to 120°. Use this angle for effective digging.

Digging ditches

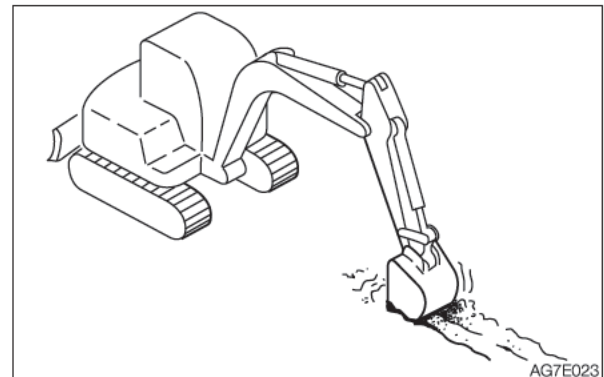

Install a bucket suited for digging ditches and set the crawlers parallel to the ditch to be dug for greater efficiency. When digging wide ditches, dig the sides first, and then dig the center.



OPERATION CAUTIONS ON OPERATING

Digging side drains

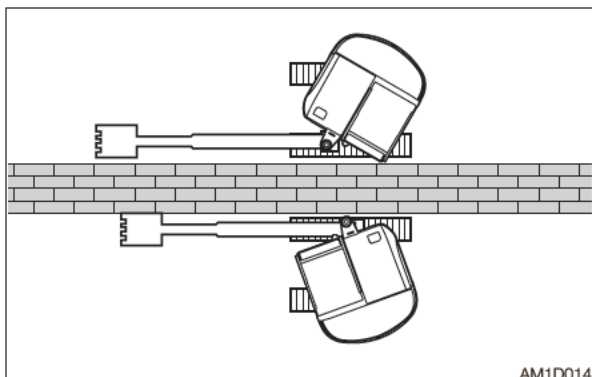

Use the boom swing function to dig side ditches as shown in the figure.

Loading

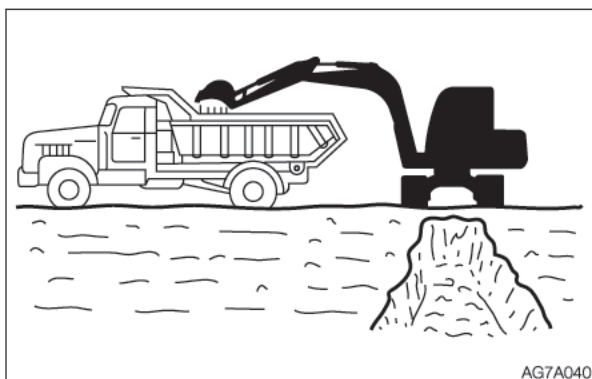

When loading dirt onto a truck bed, load from the back of the truck, as it is easier and able to load more load than doing it from the front.

Also, use a small slewing angle for greater efficiency.

Leveling

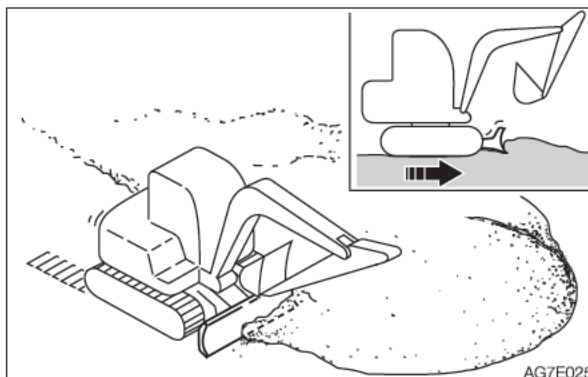

1. Bring the hoe attachment close to the body.
2. Gradually remove the dirt from the side of the mound.
3. Once the mound is low, remove the dirt from the top. If the load becomes too heavy for the machine body, adjust by raising or lowering the dozer blade.



PARKING THE MACHINE

PARKING

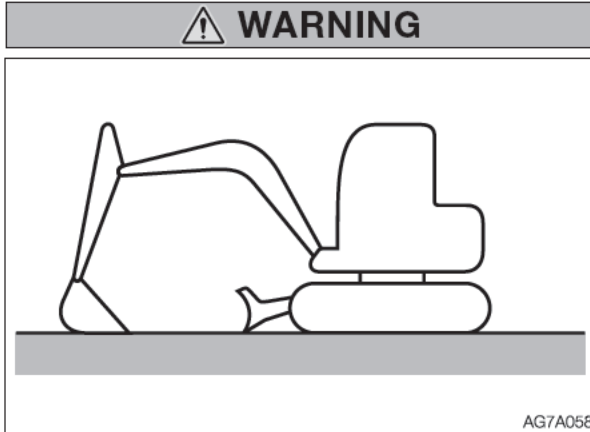

- Park the machine on a flat, rigid and safe ground. Set the parking brake.

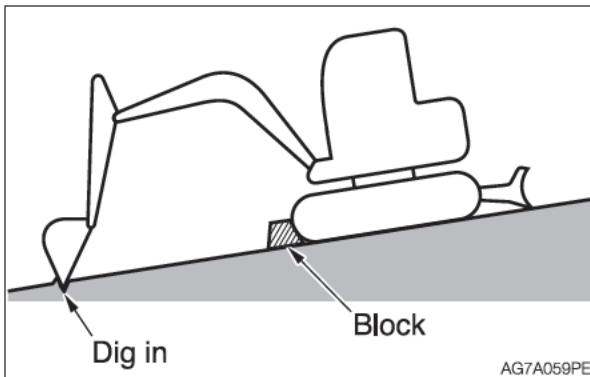

If you must park on a slope or incline, park the machine securely and block the movement of the machine.

- When parking on a street, use barriers, caution signs, lights, etc., so that the machine can easily be seen even at night to avoid collision with other vehicles.
- Before leaving the operator's seat, raise the safety lock lever to engage the lock and stop the engine. Also, be sure to remove the key, lock the door and covers, take it with you and store it in a specified place.

1. Set the left and right travel levers to the neutral position.
2. Return the throttle controller to set the engine to low idling.

3. Lower the bucket and the dozer blade to the ground.
4. Raise the safety lock lever to the locked position.
5. Stop the engine and remove the key. Refer to "Stopping the engine" on page 3-5.
For machines equipped with accumulator: Refer to "Operating the machine with an accumulator" on page 2-51.

INSPECTION AND CHECKS AFTER STOPPING THE ENGINE

1. Check for oil or water leak and inspect the working equipment, covers and undercarriage. If any irregularities are found, repair.
2. Fill up the fuel tank.
Refer to "Inspecting the fuel level" on page 5-19.
3. Remove any paper scraps or dirt from the engine room.
4. Remove any mud from the undercarriage.

Locking

Be sure to lock the following places:

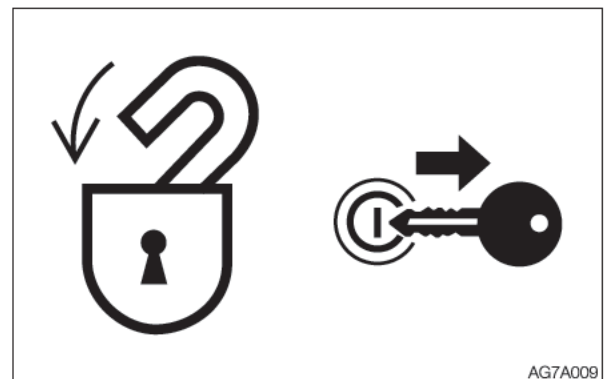

- Cab door
- Engine hood
- Covers



HANDLING IN COLD CLIMATES

PREPARING FOR COLD CLIMATES

Starting engine in cold climates is not easy, and it becomes more difficult if the coolant freezes. Prepare for cold-climate problems as follows.

Replacing the fuel and lubricant

Replace the hydraulic oil, engine oil and fuel with those intended for cold climates. Refer to “Fuel and lubricant table” on page 5-4.

Engine coolant

WARNING

The engine coolant is combustible. Keep away from flame. Use long-life coolant (antifreeze) and tap water for the engine coolant.

Note: New machines are delivered with JIS Type 2 long-life coolant (antifreeze) at a concentration of 50%. Refer to “Fuel and lubricant table” on page 5-4.

Battery

As the temperature drops, the battery performance decreases. Inspect the battery. If it is discharging, contact a Takeuchi service agent to have the battery recharged. Refer to “Inspecting the battery fluid level and replenishing” on page 5-32.

CAUTIONS AFTER OPERATIONS

Observe the following cautions to prevent mud, water, or the undercarriage from freezing and making it impossible for the machine to move.

- Remove all mud and water from the machine body. In particular, wipe the hydraulic cylinder rod clean to prevent damage to the seal caused by mud or dirt on the rod surface getting inside the seal together with drops of water.
- Park the machine on hard and dry ground. If this is impossible, park the machine on a wooden board placed on ground.
- Drain any water in the fuel tank to prevent it from freezing. Refer to “Draining the water from the fuel tank” on page 5-31.
- As the battery capacity drops markedly in low temperatures, cover the battery or remove it from the machine and keep it in a warm place. If the electrolyte level is low, add distilled water in the morning before beginning work. To prevent the battery electrolyte from freezing in the night, do not add water after the day’s work.

AFTER THE COLD CLIMATE

When the climate becomes warmer, do as follows:

- Replace the fuel and oil for all parts with those specified in the “Fuel and lubricant table”. Refer to “Fuel and lubricant table” on page 5-4.
- If a coolant of “one season type” is used, drain the cooling system completely, clean out the inside of the cooling system thoroughly, and fill with tap water. Refer to “Cleaning the engine cooling system” on page 5-48.



HANDLING RUBBER CRAWLERS

Rubber crawlers have an inherent weakness, lack of strength, due to their use of rubber. Be sure to observe the prohibitions and cautions below to prevent the crawlers from being damaged or coming off.

PROHIBITIONS

Do not travel or operate the machine in the following places:

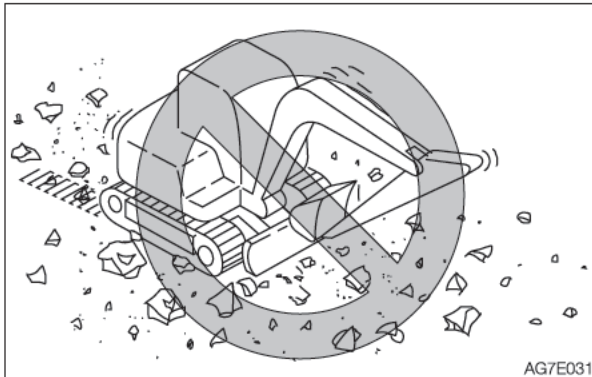

- Traveling and slewing on crushed rock, extremely rough hard rock, steel beams, scrap iron, or near the edges of steel plates will cause damage to the rubber crawlers.

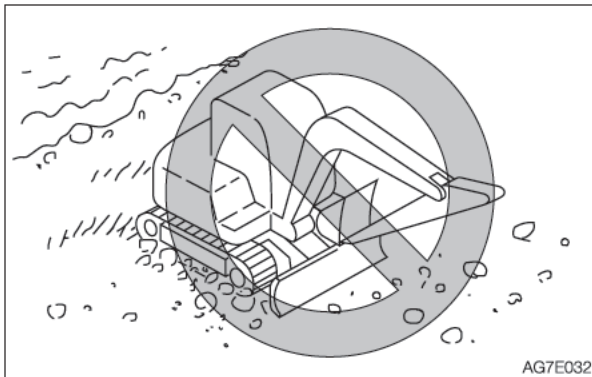

- Traveling on riverbeds or places where there are large numbers of boulders may cause the stones to get caught and damage the crawler or make the crawler come off.
- Do not use the machine on the seashore. The salt may corrode the steel core.

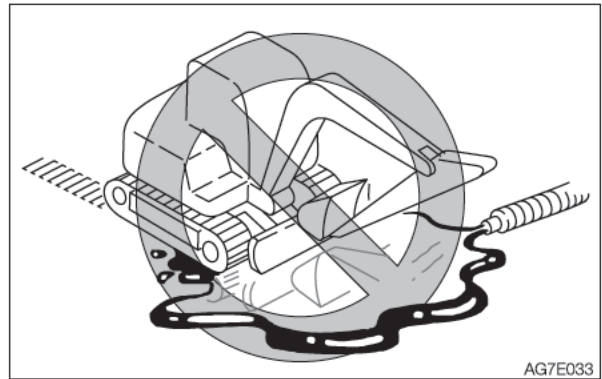

- Do not let fuel, oil, salt or chemical solvents get on the crawlers. These substances may corrode the bonding of the steel cores on the crawlers, resulting in rust or peeling. If any of these substances gets on the crawler, immediately clean it off with water.

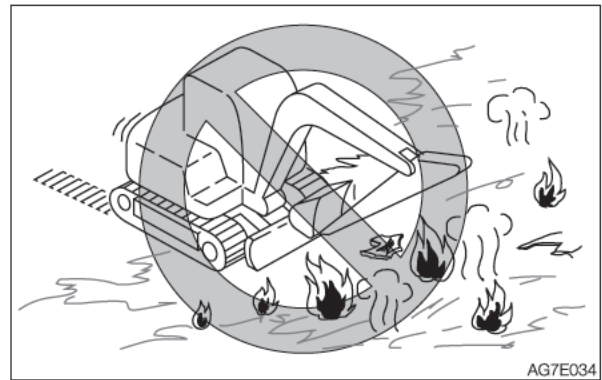

- It will cause an irregular wear or damage to the lugs, if the machine travels on irregular surfaces such as recently paved with asphalt, exposed to a bonfire or of hot iron sheets under the blazing sun.
- Do not move earth in places where the rubber crawlers may slip. Doing so may speed up lug wear.



CAUTIONS

Observe the following cautions when operating the machine:

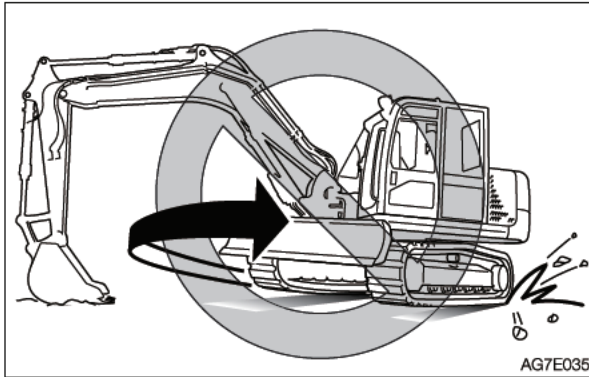

- Do not turn the undercarriage with the front of the machine body lifted using the hoe attachment (the upperstructure is not turned). Doing so will twist the crawlers with the load concentrated on a single point on the crawler belt, causing rapid damage to the crawlers.
- Avoid changing course abruptly or spin-turning on concrete surfaces whenever possible. Doing so may wear or damage the rubber crawlers.
- Avoid drops that may expose the rubber crawlers to strong shocks.
- Salt, potassium chloride, ammonium sulfate, potassium sulfate, and triple superphosphate of lime can damage the crawler belts. If any of these substances gets on the crawler belts, wash it off thoroughly with water.
- Do not let the sides of the rubber crawlers rub against concrete or walls.
- Do not damage the rubber crawlers by hitting the bucket against them.
- Be especially careful on snowy or frozen surfaces in winter, as the crawler belts tend to slip in such conditions.
- Use rubber crawler belts at temperatures between -25°C to $+55^{\circ}\text{C}$ (-14°F to 131°F).
- When storing the rubber crawlers for long periods of time (three months or more), do so indoors in a place not exposed to direct sunlight or rain.

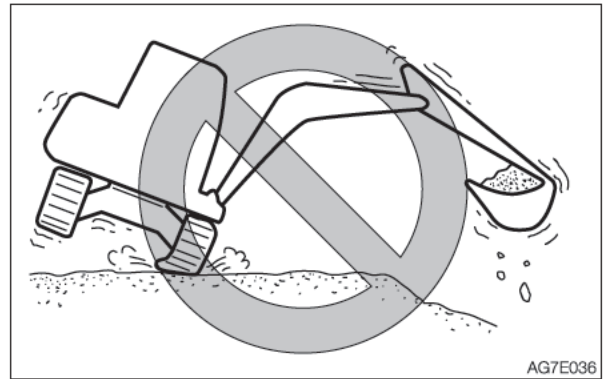

- Rubber crawler belts are not as stable as steel crawler belts since the entire lugs are made of rubber. Be very careful when slewing and swinging sideways.

PREVENTING THE RUBBER CRAWLERS FROM COMING OFF

Observe the following cautions to prevent the crawler from coming off.

- Always keep the crawlers at the proper tension.

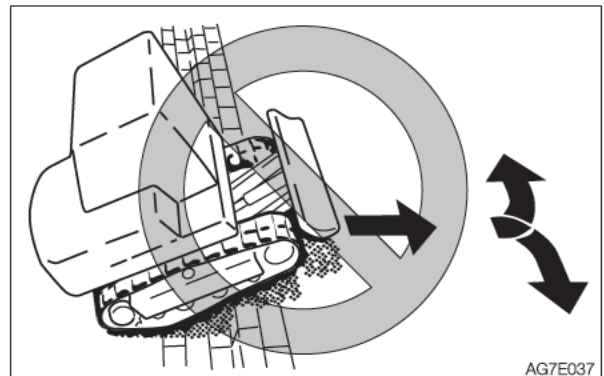

- When traveling over a large step such as a cobblestone or rock (20 cm (8 in.) or deeper), climb up the step at the right angle and do not change courses on top of the step.



OPERATION HANDLING RUBBER CRAWLERS

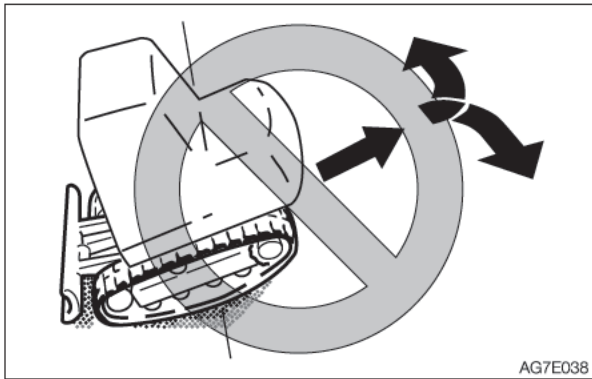

AG7E038

- When climbing in reverse, do not change directions at the point where the slope starts.

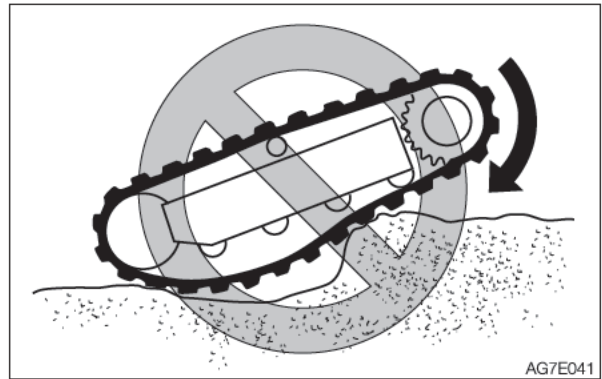

AG7E041

- Do not change directions when the crawler belts are slack as shown in the figure.

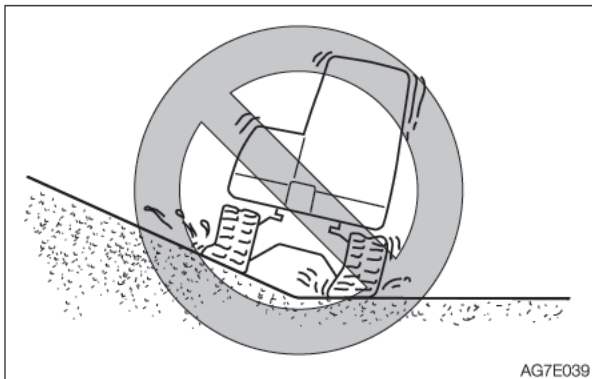

AG7E039

- Avoid traveling by setting one crawler on a slope or projecting portion and the other crawler on a flat surface (with the machine at a tilt of 10° or more). Travel with both crawlers set on flat surfaces.

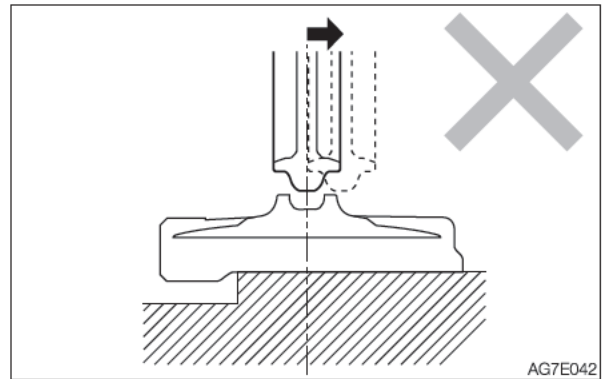

AG7E042

- The rubber crawler belts will come off if the machine travels backward in this condition.

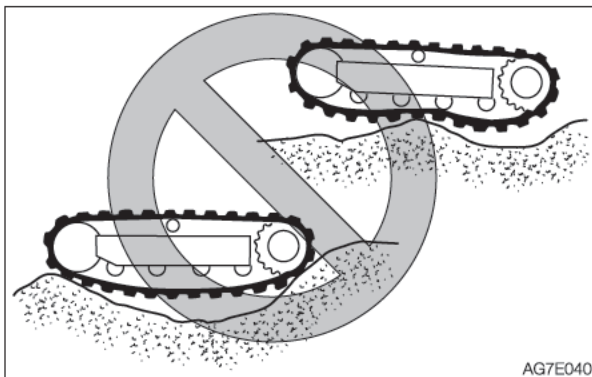

AG7E040

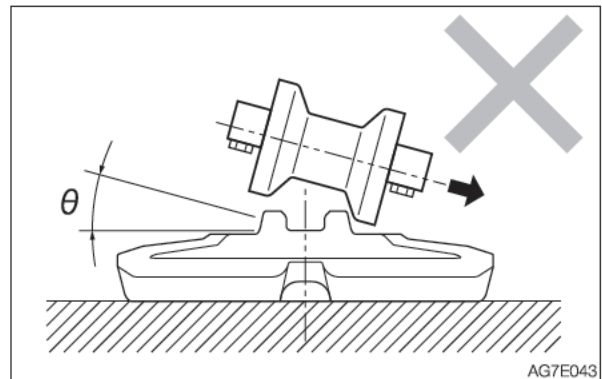

AG7E043

- The rubber crawler belts will come off if the machine turns in this condition.

TRANSPORT



LOADING AND UNLOADING

WARNING

The machine may roll or tip over or fall while being loaded or unloaded. Take the following precautions:

- Select a firm, level surface and keep sufficient distance from road shoulders.
- Secure the ramps of adequate strength and size to the truck bed. The slope of the ramps must not exceed 15°. If the ramps are bowed down too low, support them with poles or blocks.
- Never use the working equipment to load or unload the machine. Doing so may result in tipping over or falling down of the machine.
- Keep the truck bed and loading ramps clean of oil, soil, ice, snow, and other materials to prevent the machine from sliding sideways. Clean the crawlers.
- Chock the transporter wheels to prevent movement.
- Turn off the deceleration switch and auto-deceleration switch. Otherwise, the engine speed may suddenly increase to cause troubles.
- When being loaded or unloaded, travel slowly in 1st (low) gear by following the signal from the signal person.
- Never change courses on the ramps.
- Do not slew/swing on the ramps. The machine may tip over.
- When slewing/swinging on the truck bed, do it slowly as the footing should be unstable.
- Lock the cab door after being loaded, if applicable. Otherwise, the door may open during transport.
- Chock the tracks and secure the machine to the truck bed with wire rope or chain.

When loading or unloading the machine, be sure to use ramps or a platform and follow the procedure below.

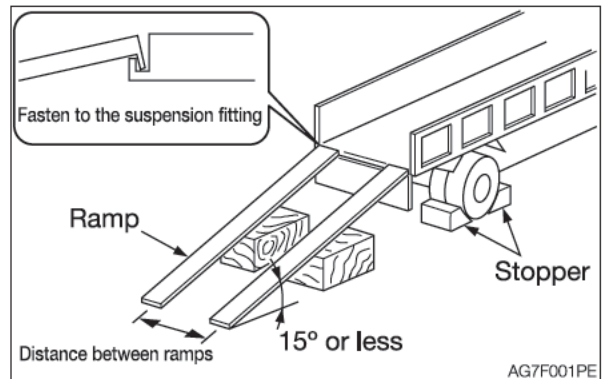

1. Set the parking brake on the transporter and chock the wheels.
2. Fix the ramps securely to the truck bed. The slope of the ramps must not exceed 15°.
3. Align the center of the truck bed with the center of the machine, and of the ramp with the center of the crawler.
4. Make sure the dozer blade does not hit the ramps.
5. Lower the hoe attachment as far as possible without letting it touch the transporter.
6. Decrease the engine speed.

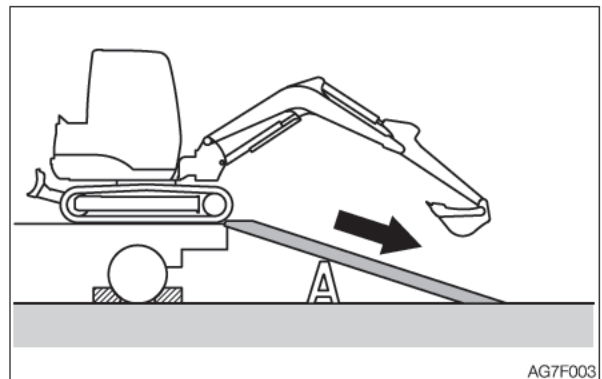
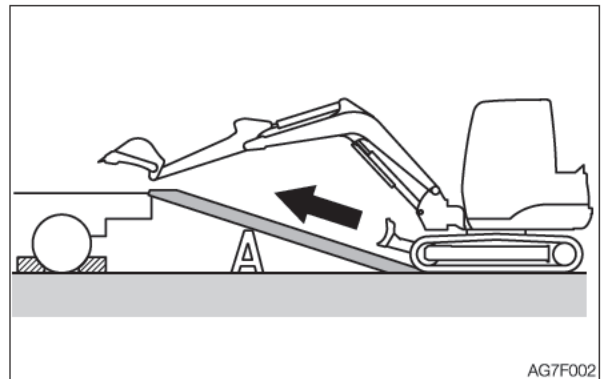



TRANSPORT
LOADING AND UNLOADING

7. Drive the machine straight toward the ramps and travel up or down the ramps at 1st (low) speed, by following the signal from the signal person.
8. Load the machine at the specified position on the transporter.
Refer to “Transporting posture” on page 4-6.



HOISTING THE MACHINE

WARNING

- Know and use the correct crane signals.
 - Check the hoisting equipment for damaged or missing parts on a daily basis and replace as necessary.
 - When hoisting, use a wire rope capable of lifting the machine mass.
 - Hoist the machine in such a manner described in the procedure below. Do not do it in any other manner. Doing so is dangerous as it may result in the machine losing its balance.
 - Do not hoist the machine with an operator on it.
 - When hoisting, hoist slowly so that the machine does not tip.
 - Keep everyone out of the area when hoisting. Do not move the machine over the heads of the persons.
-

IMPORTANT: This hoisting method applies to machines with standard specifications. The center of gravity differs according to the attachments and optional equipment installed. Contact your Takeuchi service agent for details.

Hoisting

1. Slew the upperstructure so that the dozer blade is at the rear of the machine (set the upperstructure parallel to the track frame).
2. Raise the dozer blade fully.
3. Extend the bucket cylinder and arm cylinder fully to raise the boom to its uppermost position.
4. If the boom is swung to either the left or right side, set it in the neutral position.
5. Raise the safety lock lever to the locked position.
6. Stop the engine, remove the starter key and get off the machine.
7. Install the wire ropes as shown on the figure below. Install the wire ropes and hoisting attachment without letting them touch the machine body.
8. Hoist the machine slowly until it leaves the ground.
9. Stop hoisting until the machine becomes stable, and then start hoisting the machine slowly again.



TRANSPORT
HOISTING THE MACHINE

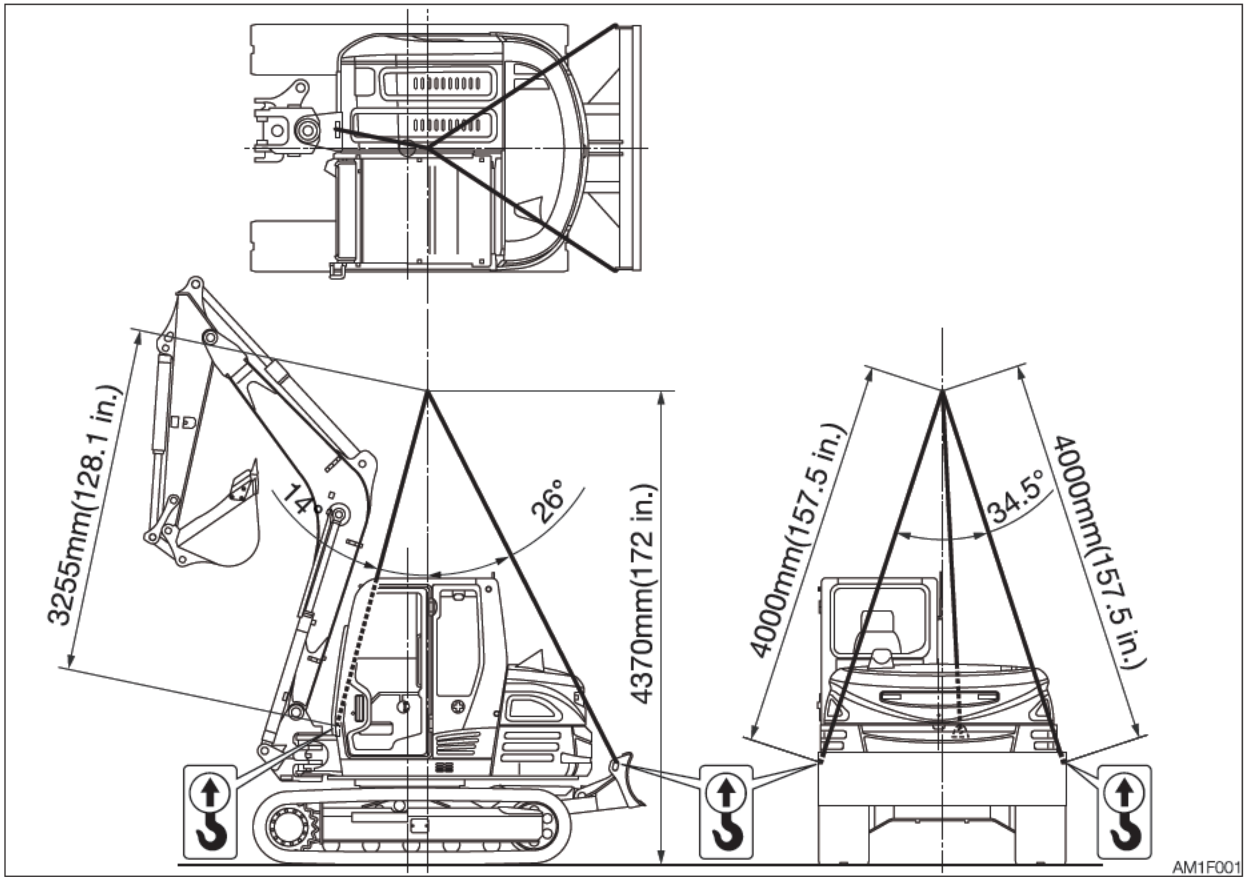



SECURING THE MACHINE

After loading the machine at the specified position, secure it as described below.

Transporting posture

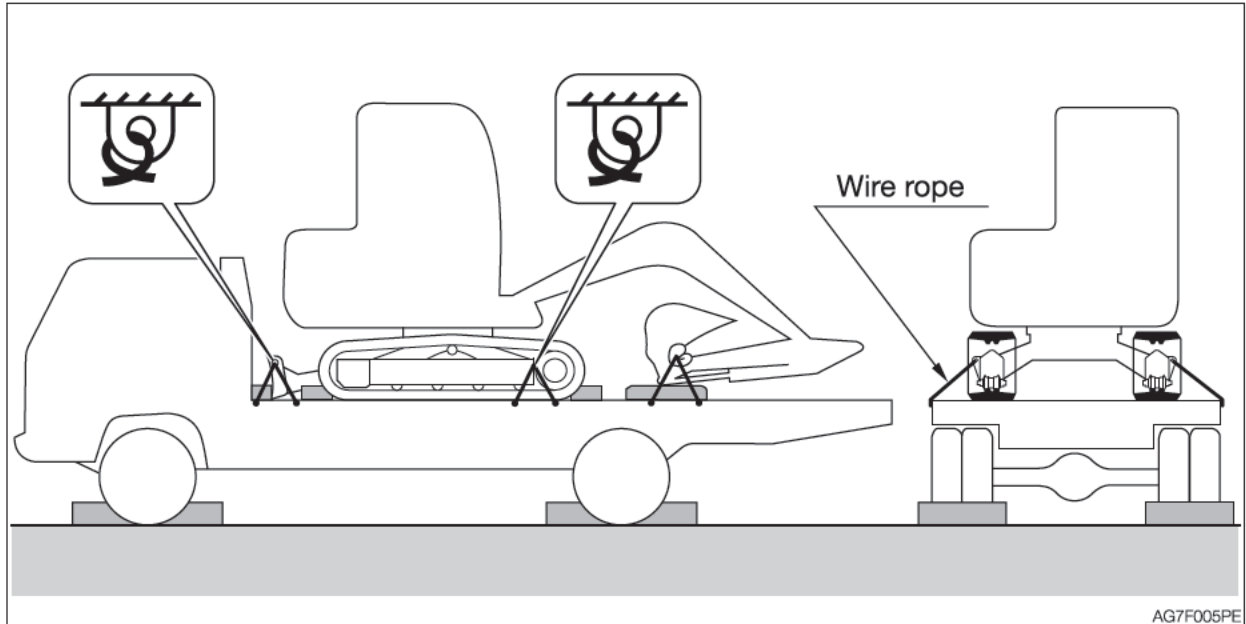

1. Lower the dozer blade.
2. Extend the bucket cylinder and arm cylinder fully, and then lower the boom.
3. Raise the safety lock lever to the locked position.
4. Stop the engine, remove the starter key and lock all locks.
5. Place the stoppers (chocks) in front and behind the crawlers.
6. Install a chain or wire rope over the lower frame of the machine and fasten it securely to prevent the machine from slipping sideways.
7. Secure the bucket with a chain or wire rope.

IMPORTANT: Place a wooden block under the bucket to protect the floor from damage caused by the bucket.

Precautions to be taken during transportation

WARNING

- Know and follow the applicable safety rules, vehicle code and traffic laws when transporting the machine.
- Select the best transport route by considering the length, width, height and weight of the truck with the machine loaded on it.
- Never abruptly start or stop or run at a high speed at the sharp curves during transport. Doing so will move or lose the balance of the loaded machine.

MAINTENANCE



GENERAL

MAINTENANCE OVERVIEW

To keep the machine in good condition and use it for a long period, perform the inspection and maintenance properly and safely following the procedures recommended by this manual.

The inspection and maintenance items are divided into groups according to the machine's total operating time: every 10 hours (walk-around and daily inspection), every 50 hours, every 250 hours, etc. Refer to the hour meter readings to determine when to schedule an inspection and maintenance. Items for which it is not possible to determine the inspection and maintenance interval are included under "When Required".

When operating the machine in extremely harsh environments (with high dust levels or high temperatures), inspection and maintenance should be performed earlier than the times specified on the Maintenance List.

CAUTIONS ON MAINTENANCE

Do not perform any other inspection and maintenance works than those listed in this manual.

For works not listed in this manual, ask your sales or a service dealer for help.

Keep the machine clean

- Clean the machine before performing inspection and maintenance and try to keep it clean.
- Stop the engine before washing the machine. Cover the electrical parts so that water cannot enter. Water on electrical parts could cause short-circuits or malfunctions. Do not use water or steam to wash the battery, electronic control components, sensors, connectors or the operator's compartment.

Fuel, lubricant and grease

- Choose fuel, lubricant and grease by following to the "Fuel and lubricant table".
- Use fuels, lubricants and greases which do not contain water, and be careful to keep dirt out when changing or replenishing fuel, lubricant or grease.
- Store fuels, lubricants and greases in the prescribed places and in such a way that no water or dirt can get in them.

Cautions on refueling

- If the port includes a strainer, do not remove the strainer when fueling.
- After fueling, be sure to securely tighten the fuel filler cap.
- Do not add more than the specified amount of fuel.

Do not use fuel to clean parts

Do not use fuel to clean parts. Use a non-combustible cleaning agent.

Keep dirt out

When mounting and removing parts, do so in a place where there is no dust, clean the working area and the part, and keep dirt out.



Clean the installation surfaces

When installing and removing parts, be sure that the surfaces of contact of the parts are clean. If the sealing grooves of the surface of contact are damaged, consult your sales or service dealer for repair or release.

Seals and split pins

- Be sure to replace all seals and cotter pins with new ones.
- When installing, be careful not to damage or twist the seal.

Sealing tape

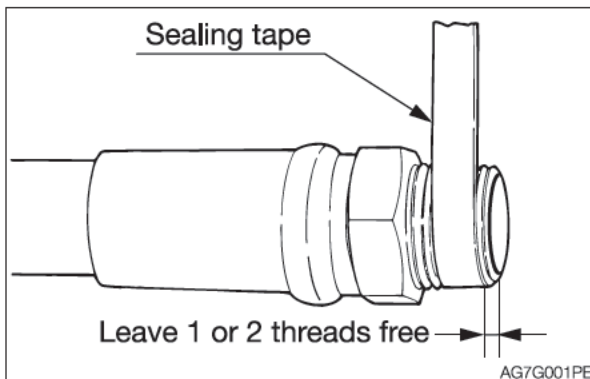

- When wrapping the plug with sealing tape, remove any old sealing tape from the threads and clean the threads.
- Wrap the thread tight with seal tape starting 1 or 2 threads away from the thread end.

Disposing of wastes

- Always collect oil that is drained from the machine in containers. Improperly disposed waste oil can cause environmental harm.
- Follow appropriate laws and regulations when disposing of harmful objects such as oil, fuel, cooling water, coolant, filters and batteries.

Check after maintenance

- Gradually increase the engine speed from a low idle to maximum speed and check that there is no oil or water leaking from serviced parts.
- Operate each control lever and check that the machine is operating properly.

Cautions on handling of battery wiring

- Disconnect the wiring from the both terminals (+ and -) on the battery before working on the electrical system or doing electric welding.
Always disconnect it from the earth side (-).
When connecting, connect the earth side last.
- Do not disconnect the battery wiring while the engine is moving. Otherwise, the electric circuits of the rotary converter or others may be damaged.



SERVICE DATA

FUEL AND LUBRICANT TABLE

Select the appropriate fuel, lubricant and grease according to the temperature by referring to the table below.

- Regardless of the specified time, change the oil if it becomes too dirty or degraded.
- When refilling, never mix oils of different brands. If a brand is to be changed, replace the whole fuel/oil.

Fuel

Diesel fuel specifications

Diesel fuel should comply with the following specifications. The table lists several worldwide specifications for diesel fuels.

Diesel fuel specification	Location	Diesel fuel specification	Location
ASTM D975 No.1-D S15, S500 No.2-D S15, S500	USA	ISO 8217DMX	International
EN590: 96	European union	BS2869-A1 or A2	United kingdom

Fuel tank	Diesel fuel	<p>To maintain the performance and service life of the engine, always use clean and high-quality fuel.</p> <ul style="list-style-type: none"> • To avoid freezing in cold climates, use a diesel fuel that still functions when the temperature is at least 12°C (53.6°F) below the lowest expected ambient temperature. • Use a diesel fuel that has a cetane number of 45 or higher. When operating at a very low temperature or at a high altitude, a higher cetane number fuel will be required. • Use fuel with sulfur content of less than 0.05 to 0.0015% by volume. <TB285> Especially in the U.S.A. and Canada, ultra-low sulfur fuel should be used. A higher sulfur content fuel may cause sulfuric acid corrosion in the cylinders of the engines. • Never mix kerosene, used engine oil, or residual fuels with the diesel fuel. • Poor quality fuel can reduce engine performance and / or cause engine damage. • Fuel additives are not recommended. Some fuel additives may cause poor engine performance.
-----------	-------------	--



Lubricant

Location	Type	Type by air temperature								When to replace
		-4 -20	14 -10	32 0	50 10	68 20	86 30	104°F 40°C		
Engine oil pan	Diesel engine oil <TB285> API: CF class or higher <TB290> API: CF-4 class or higher									Every 250 hrs after the initial 50 hrs.
Hydraulic oil tank	Takeuchi genuine hydraulic oil 46									Every 4000 hrs.***
	Anti-wear hydraulic oil									Every 2000 hrs.***
Engine cooling system	Cooling water (water + coolant)** SAE: J814C, J1941, J1034 or J2036 ASTM: D6210 or D4985(USA)									Every 1000 hrs.
Travel reduction gear	Gear oil API: GL-4									Every 1000 hrs after the initial 250 hrs*.
Slew bearing	Lithium based grease EP-2									Every 50 hrs.
Working equipment	NLGI No.2									Daily or every 10 hrs.

- * : If the ratio of traveling time to total operating time is high, replace the gear oil earlier than the specified time.
- ** : For water, use tap water (soft). Do not use well or river water. When the ambient temperature drops below 0°C (32°F), add coolant (antifreeze). Follow the coolant manufacturer's instructions to determine the mixture ratio.
- *** : The hydraulic oil replacement interval depends on the type of hydraulic oil being used. New machine are delivered with Takeuchi genuine hydraulic oil 46, and the hydraulic oil replacement intervals indicated in this manual assume that Takeuchi genuine hydraulic oil 46 is being used. When using conventional antiwear hydraulic oil, the hydraulic oil should be replaced every 2000 hours.



Volume
<TB285>

Engine oil pan	Engine cooling system	Hydraulic oil tank	Fuel tank	Travel reduction gear
Upper limit 10.2 L (10.8 US qt.) Lower limit 5.7 L (6 US qt.)	14 L (14.8 US qt.)	System 140 L (37 US gal.) Tank 73 L (19.3 US gal.)	128 L (33.8 US gal.)	1.1L X 2 (1.16 US qt.) X 2

<TB290>

Engine oil pan	Engine cooling system	Hydraulic oil tank	Fuel tank	Travel reduction gear
Upper limit 15 L (15.9 US qt.) Lower limit 11 L (11.6 US qt.)	16 L (16.9 US qt.)	System 140 L (37 US gal.) Tank 73 L (19.3 US gal.)	128 L (33.8 US gal.)	1.1L X 2 (1.16 US qt.) X 2

REGULARLY REPLACE THE HYDRAULIC OIL

When a hydraulic breaker is used, the oil deteriorates more quickly than that used for a usual excavation operation. Be sure to replace the hydraulic oil and the return filter elements.

- Failure to replace these in time can lead to damage to the machine and the breaker hydraulic system. To prolong the service life of the hydraulic devices, properly replace the hydraulic oil and the return filter elements according to the table below.
- When replacing the hydraulic oil, clean the suction strainer.

Replacement interval (hours)

Item	Hydraulic oil	Filter element
1st time	—	25
2nd time	—	100
Periodically	1200 (600)	200

When the breaker operating ratio is 100%. Refer to “Hydraulic breaker” on page 8-6.

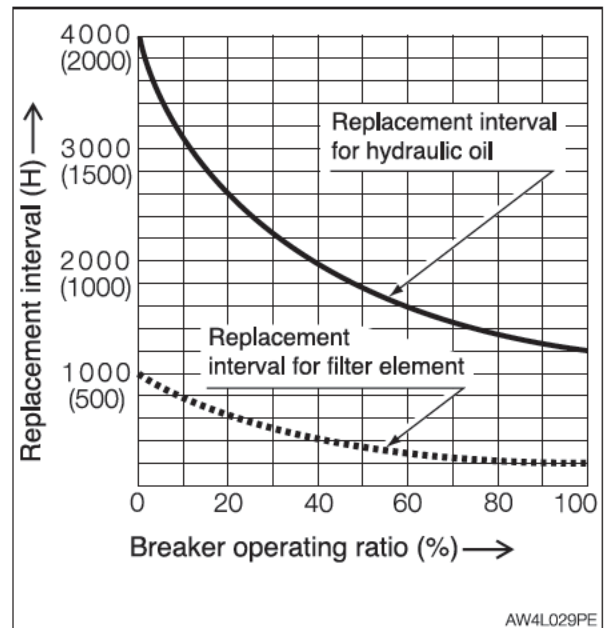

(): When a conventional antiwear hydraulic oil is used.



LIST OF CONSUMABLES

Periodically replace consumables such as filters and elements according to the table below.

<TB285>

System	Item	Part name	Part No.	When to replace
Hydraulic system	Hydraulic oil return filter	Element	1551103900	Every 1000 hrs after the initial 250 hrs.
	Pilot line filter		1551200601	
	Air breather filter		1552002715	Every 1000 hrs.
Engine lubrication system	Engine oil filter	Cartridge	Y129150-35153	Every 250 hrs after the initial 50 hrs.
Fuel system	Fuel filter	Cartridge	Y129907-55801	Every 500 hrs.
	Water separator filter	Cartridge	Y129917-55850	
Air cleaner system	Air cleaner	Primary (Outer) element	1911113001	Every 1000 hrs. or after 6 cleanings (whichever comes first)
		Secondary (Inner) element	1911113002	When the primary elements are replaced.

<TB290>

System	Item	Part name	Part No.	When to replace
Hydraulic system	Hydraulic oil return filter	Element	1551103900	Every 1000 hrs after the initial 250 hrs.
	Pilot line filter		1551200601	
	Air breather filter		1552002715	Every 1000 hrs.
Engine lubrication system	Engine oil filter	Element	I8-98018-8580	Every 250 hrs after the initial 50 hrs.
Fuel system	Pre-fuel filter	Element	1552002502	Every 500 hrs.
	Main fuel filter		I8-98143-0410	
	Feed pump filter	Repair kit	I8-98071-4010	
Air cleaner system	Air cleaner	Primary (Outer) element	1911113001	Every 1000 hrs. or after 6 cleanings (whichever comes first)
		Secondary (Inner) element	1911113002	When the primary elements are replaced.



LIST OF TOOLS

Code	Part name	Part No.	Remarks
1	Spanner	Y28110-100120	10 - 12
2	Spanner	Y28110-140170	14 - 17
3	Screwdriver	Y104200-92350	(+) (-) replaceable shank
4	Filter wrench	Y119640-92750 1691903560	<TB285> <TB290>
5	Hammer	1690300330	3/4
6	Monkey wrench	1690400250	250 mm
7	Pliers	1690500200	200 mm
8	Spanner	1690001013	10-13
9	Spanner	1690001922	19-22
10	Spanner	1690002427	24-27
11	Spanner	1690002730	27-30
12	Spanner	1690003236	32-36
13	Spanner	1690100041	41
14	Hex. wrench	1690600500	5 mm
15	Hex. wrench	1690600600	6 mm
16	Hex. wrench	1690600800	8 mm
17	Hex. wrench	1690601000	10 mm
18	Hex. wrench	1690601200	12 mm
19	Tool case	1691400001	
20	Case	1691900001	
21	Grease gun	1691060610	600 cc
22	Drain connector	1554512601	



LIST OF TIGHTENING TORQUES

Nuts and Bolts (for ISO strength category 10.9)

Tighten nuts and bolts at the torques shown on the table below, unless otherwise specified.

- The tightening torques used for the mounted plastic covers are not listed in the table below. Consult your sales or service dealer for details. They will be damaged if over tightened.
- When replacing nuts and bolts, replace them with nuts and bolts of the same size and standards.
- Tighten nuts and bolts alternately (top, bottom, left then right) or in 2 or 3 times so that they are evenly tightened.

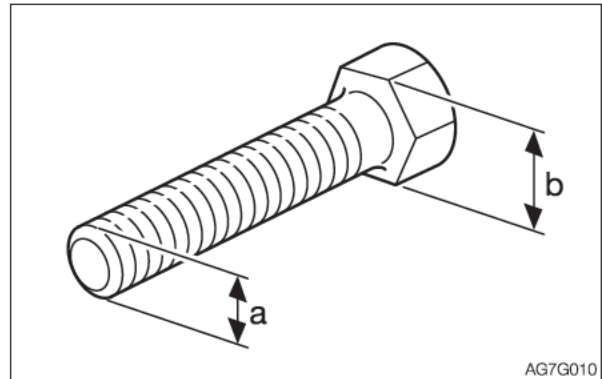
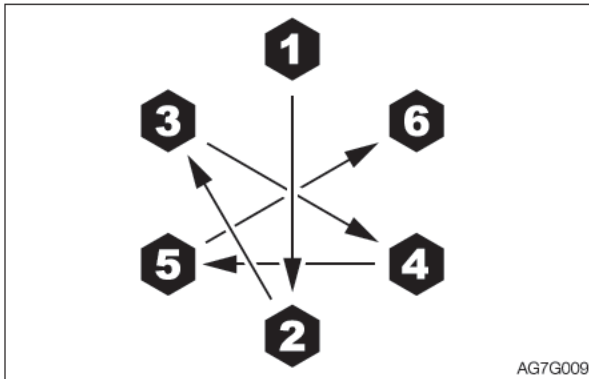

Classification	Head width (b)	Size (a) x pitch	Tightening torque	
			General connection points	
	mm	mm	N·m	ft-lb.
Coarse	10	M6 x 1.0	9.8±0.5	7.2±0.4
	12, 13	M8 x 1.25	22.6±1.1	16.6±0.8
	14, 17	M10 x 1.5	47.1±2.4	34.7±1.7
	17, 19	M12 x 1.75	83.4±4.1	61.5±3.0
	19, 22	M14 x 2.0	134.4±6.7	99.1±4.9
	22, 24	M16 x 2.0	207.9±10.4	153.3±7.7
	27, 30	M20 x 2.5	410.9±20.5	303.1±15.1
Fine	12, 13	M8 x 1.0	24.5±1.2	18.1±0.9
	14, 17	M10 x 1.25	50±2.5	36.9±1.8
	17, 19	M12 x 1.5	87.3±4.3	64.4±3.2
	19, 22	M14 x 1.5	135.3±6.8	99.8±5.0
	22, 24	M16 x 1.5	220.6±11	162.7±8.1
	27, 30	M20 x 1.5	452.1±22.6	333.4±16.6



SAFETY-CRITICAL PARTS

To use the machine safely, periodically perform inspection and maintenance. The safety-critical parts listed below must be periodically replaced for an increased safety. Serious injury or a fire could result if they are worn or damaged.

List of safety-critical parts

Unit		Safety-critical parts to be replaced periodically	When to replace
Fuel system		Fuel hoses	Every 2 years
		Packing on fuel filler cap	
Heater & AC systems		Heater hoses	
		Air conditioner hoses	
Hydraulic system	Main body	Hydraulic hoses (pump - delivery)	
		Hydraulic hoses (pump - suction)	
		Hydraulic hoses (slew motor)	
		Hydraulic hoses (travel motor)	
	Working equipment	Hydraulic hoses (boom cylinder piping)	
		Hydraulic hoses (second boom cylinder piping)	
		Hydraulic hoses (arm cylinder piping)	
		Hydraulic hoses (bucket cylinder piping)	
		Hydraulic hoses (swing cylinder)	
		Hydraulic hoses (blade cylinder)	
		Hydraulic hoses (angle blade cylinder)	
		Hydraulic hoses (pilot valve)	
		Hydraulic hoses (auxiliary piping)	
	Seat belt	Every 3 years	



MAINTENANCE
SAFETY-CRITICAL PARTS

The material of the safety-critical part listed above tends to change over time and cause wear or deterioration. It is difficult to determine the degree of deterioration at the periodic inspection, and thus they need to be replaced with new ones after a certain time to maintain their proper performance even if they appear in good condition. Note that regardless of the replacement schedule, replacement must be performed immediately if a symptom of wear is found. If a hose clamp is deformed or cracked, replace it together with the hose immediately. When replacing the safety-critical parts, ask your sales or service dealer.

In addition to the safety-critical parts, inspect the hydraulic hoses and retighten or replace as necessary. When replacing the hydraulic hoses, replace the O-rings and seals at the same time.

Check the fuel and hydraulic hoses according to the periodic schedule described below. Refer to "Maintenance".

Type of inspection	Inspection item
Daily inspection	Leakage from the connecting parts of hydraulic or fuel hoses
Monthly inspection	Leakage from the connecting parts of hydraulic or fuel hoses Damaged hydraulic or fuel hoses (cracks, wear and tear)
Annual inspection	Leakage from the connecting parts of hydraulic or fuel hoses Deteriorated, twisted, damaged hydraulic or fuel hoses (cracks, wear and tear) or hoses in contact with other parts of the machine



MAINTENANCE LIST

Inspection and maintenance item	Page
Walk-around inspection	
Inspecting by opening the engine hood and covers	5-14
Inspecting by walking around the machine	5-15
Inspecting while sitting in the operator's seat	5-15
Daily inspection (every 10 hours)	
Inspecting and replenishing the coolant	5-16
Inspecting and replenishing the engine oil	5-17
Inspecting the water separator and the fuel filters	5-18
Inspecting the fuel level	5-19
Inspecting the hydraulic oil tank level and replenishing	5-20
Lubricating the working equipment	5-21
After the initial 50 hours (only for new machines)	
Replacing the engine oil and the oil filter	5-22
Inspecting and adjusting the fan belt	5-24
Inspecting and adjusting the compressor belt (AC)	5-26
Every 50 hours	
Inspecting the crawler belt tension	5-28
Lubricating the slew bearing	5-30
Draining the water from the fuel tank	5-31
Inspecting the battery fluid level and replenishing	5-32
After the initial 250 hours (only for new machines)	
Replacing the hydraulic oil return filter	5-34
Replacing the pilot line filter	5-35
Replacing the travel motor gear oil*	5-36
Every 250 hours	
Replacing the engine oil and the oil filter	5-37
Inspecting and adjusting the fan belt	5-37
Inspecting and adjusting the compressor belt (AC)	5-37
Cleaning the air cleaner	5-38
Cleaning the radiator fins and oil cooler fins	5-39
Cleaning the air filters (AC)	5-40
Cleaning the condenser (AC)	5-41
Inspecting the refrigerant (gas) level (AC)	5-42

*: If the percentage of the traveling time within the total operating time is high, replace the gear oil earlier than the specified time.



MAINTENANCE MAINTENANCE LIST

Inspection and maintenance item	Page
Every 500 hours	
Replacing the fuel filter	5-44
Replacing the water separator filter <TB285>	5-46
Replacing the feed pump filter <TB290>	5-47
Every 1000 hours	
Replacing the hydraulic oil return filter	5-48
Replacing the pilot line filter	5-48
Replacing the travel motor gear oil *	5-48
Cleaning the engine cooling system	5-48
Replacing the air cleaner element	5-50
Replacing the air breather filter	5-51
Inspecting and adjusting the engine valve clearance	5-51
Retightening the engine cylinder head bolt <TB285>	5-51
Inspecting the engine compression pressure <TB290>	5-51
Inspecting and cleaning the engine starter and the alternator <TB290>	5-51
Every 1500 hours	
Inspecting and cleaning the engine fuel injectors <TB285>	5-52
Inspecting the crankcase breather system <TB285>	5-52
Every 2000 hours	
Lapping the engine valve seats <TB285>	5-53
Every 4000 hours	
Replacing the hydraulic oil and cleaning the suction strainer	5-54
When Required	
Replacing the bucket teeth and the side cutters	5-58
Replacing the bucket	5-60
Adjusting the gap between the bucket and arm	5-62
Inspecting and replenishing the windshield washer fluid	5-63
Draining the water from the water separator	5-63
Lubricating the levers and pedals	5-64
Inspecting the rubber crawlers	5-65
Replacing the rubber crawlers	5-66

*: If the percentage of the traveling time within the total operating time is high, replace the gear oil earlier than the specified time.



WALK-AROUND INSPECTION

Perform the following inspections every day before starting the engine for the first time.

WARNING

- Before operating, perform the walk-around inspections and make repairs immediately where necessary.
- Be sure to secure the engine hood or cover before working the inside. Do not keep the hood or cover open on a windy day or if the machine is parked on a slope.

Before starting the engine, look around the machine and clean any combustibles from the surroundings of the engine. Also, inspect if oil or water is leaking and any nuts or bolts are loosened.

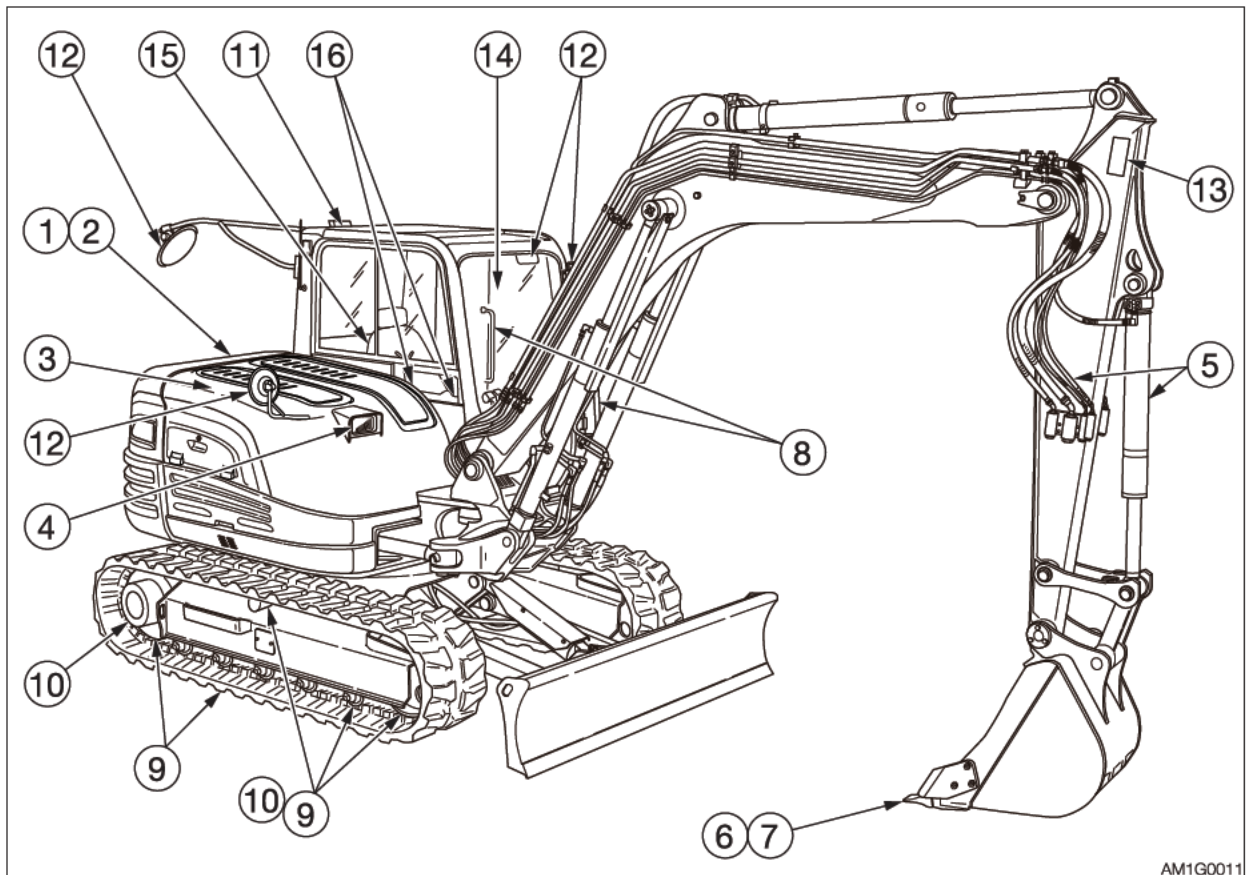

INSPECTING BY OPENING THE ENGINE HOOD AND COVERS

1. Check for any twigs, leaves, oil or other combustible materials around the engine and battery.
2. Check for oil or engine coolant water leakage around the engine.
3. Check for oil leakage from the hydraulic tank, hydraulic devices, hoses or connections.



INSPECTING BY WALKING AROUND THE MACHINE

4. Check lights for dirt, damage and burnt out bulbs.
5. Check attachments and hoses for damage.
6. Check the bucket, bucket teeth and side cutter for wear, damage and looseness.
7. Check the hook, slip stopper and hook mount of buckets with hooks for damage.
(Option)
8. Check the handrail and steps for damage and loose bolts.
9. Check the crawlers, carrier rollers, track rollers, idlers and sprockets for damage, wear and loose bolts.
10. Check for oil leakage from the travel motor, carrier rollers, track rollers and idlers.
11. Check the cab and guard for damage and loose nuts and bolts.
12. Check the mirrors for dirt or damage, and adjust them.
13. Check the labels for dirt and damage.

INSPECTING WHILE SITTING IN THE OPERATOR'S SEAT

14. Check the windshield for dirt or damage.
15. Check the seat and seat belt for dirt or damage.
Check the operator's seat for dirt, oil or other combustible materials.
16. Check the monitor, instruments and switches for dirt or damage.



DAILY INSPECTION (EVERY 10 HOURS)

Perform the following inspections every day before starting the engine for the first time.

WARNING

- Before operating, perform the daily inspections and make repairs immediately where necessary.
- Be sure to secure the engine hood or cover before working the inside. Do not keep the hood or cover open on a windy day or if the machine is parked on a slope.

INSPECTING AND REPLENISHING THE COOLANT

WARNING

- Do not remove the radiator cap or the drain plug when the cooling water is hot. Stop the engine and wait until the engine and the radiator cool before slowly loosening the radiator cap and the drain plug to remove them.
- Always wear the protective goggle and gloves when handling coolant (antifreeze). If any coolant (antifreeze) comes in contact with eyes or skin, wash it off with clean water. Otherwise, it could result in injuries.

Inspection

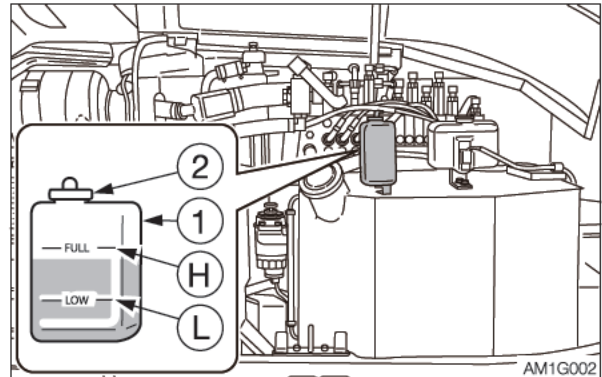

1. Open the fuel lid.
2. Inspect the cooling water level in the reserve tank (1).
The level should be between the upper limit (H) and the lower limit (L).
If it is below the lower limit (L), replenish.

Replenishing

1. Open the side cover.
2. Remove the cap (2) of the reserve tank (1).
3. Add cooling water up to the upper limit (H) of the reserve tank (1).

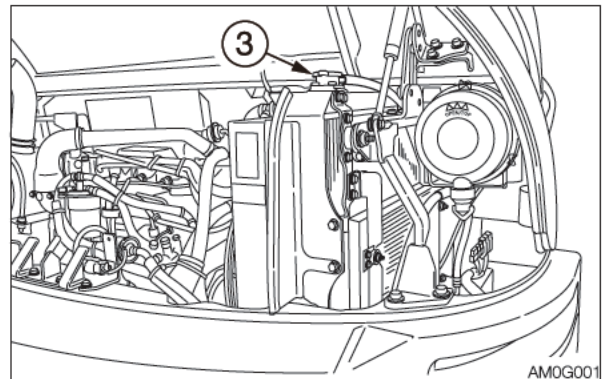

- If the reserve tank (1) is found empty at the inspection, check for water leakage and then the water level in the radiator (3). Add water to the radiator (3) as required, and then to the reserve tank (1).
4. Install the cap (2).

Note: Use only clean water (soft water), such as tap water, to replenish the coolant loss due to evaporation. If the coolant loss is due to leakage, replenish the mixture of antifreeze and clean water (soft water) prepared using the same mixing ratio used for the current coolant.

**INSPECTING AND REPLENISHING THE ENGINE OIL****⚠ WARNING**

Stop the engine and allow the machine to cool down before performing maintenance.

Inspection

<TB285>

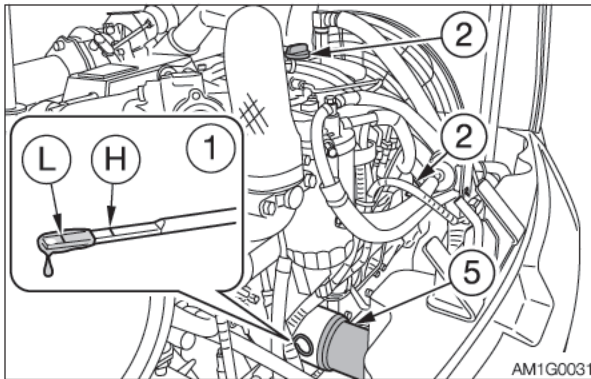

<TB290>

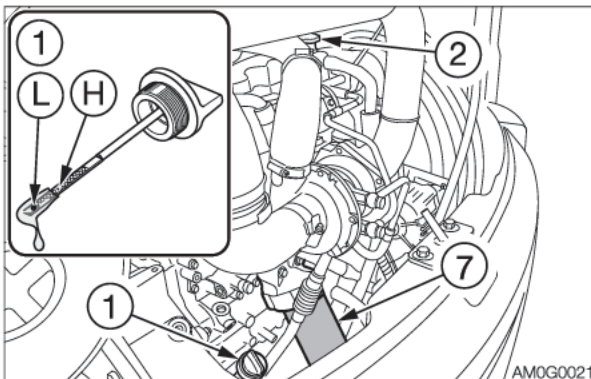

1. Open the engine hood.
2. Take out the dipstick (1) and wipe the oil off with a rag.
3. Fully reinsert the dipstick (1), and then pull it back out.
4. Check the oil on the dipstick (1).
The level should be between the upper limit (H) and the lower limit (L).
If it is below the lower limit (L), replenish.

Replenishing

1. Remove the oil filler cap (2).
2. Add oil up to between the upper limit (H) and the lower limit (L) of the dipstick (1).
Problems could arise if the oil level is either too low or too high.
3. Tighten the oil filler cap (2).
4. Start the engine, run it at low idle for about 5 minutes, then stop it.
5. After about 10 minutes, inspect the oil level.



INSPECTING THE WATER SEPARATOR AND THE FUEL FILTERS

WARNING

- Do not smoke or permit open flames while handling fuel or working on the fuel system.
- Stop the engine in a well-ventilated place and allow it to cool down before performing maintenance.
- Clean up spilled fuel immediately.

Water separator

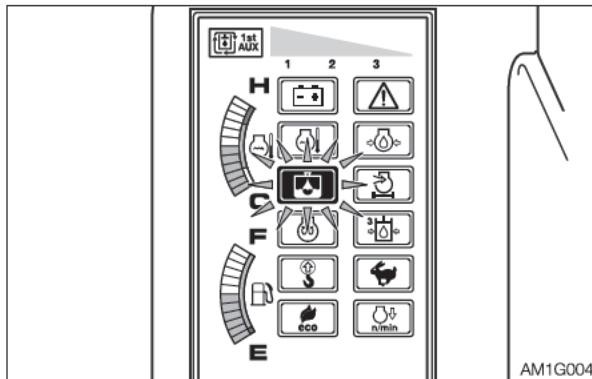

1. Turn the starter switch to the ON position.
2. Inspect the water separator warning lamp.
3. If the warning lamp is flashing, drain the water.
Refer to “Draining the water from the water separator” on page 5-63.

Fuel filters <TB290>

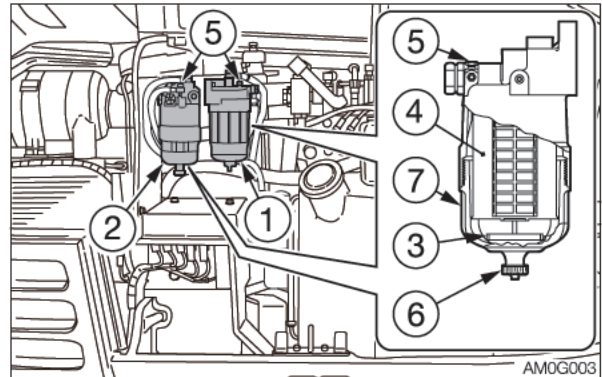

1. Open the fuel lid or the side cover.
2. Check if there is water in the pre-fuel filter (1) and the main fuel filter (2).
If water collects in the filter, the float (red ring) (3) goes up. Be sure to drain water before the float (3) goes up to the element (4).
3. Loose the vent plug (5) and then the drain plug (6) to discharge water collected inside.
4. After drainage of water, tighten each plug and bleed air from the fuel system.
Refer to “Bleeding air from the fuel system” on page 6-8.

**INSPECTING THE FUEL LEVEL****⚠ WARNING**

- Do not smoke or permit open flames while handling fuel or working on the fuel system.
- Never remove the fuel cap or add fuel when the engine is running or still hot. Do not spill fuel on the hot surface of the machine.
- Fill the fuel tank in a well ventilated place.
- Clean up spilled fuel immediately.
- Do not fill the fuel tank to capacity. Allow room for oil expansion.
- Securely tighten the fuel filler cap.
- Use the correct grade of fuel for the operating season.

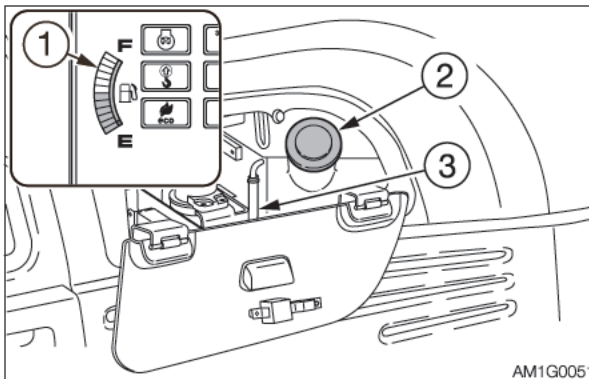

1. Check the fuel level using the fuel gauge (1).
F: Tank is full.
E: Tank is empty.
2. If the fuel level is low, open the fuel lid.
3. Add fuel from the fuel filler port (2) while watching the sight gauge (3).
Refer to "Fuel filler port" on page 2-5.



INSPECTING THE HYDRAULIC OIL TANK LEVEL AND REPLENISHING

WARNING

Oil may spurt out if caps or filters are removed or pipes are disconnected before releasing the pressure in the hydraulic system.

- Press the air breather button to relieve the internal pressure from the tank.

Inspection

The oil level changes with the oil temperature. Inspect the oil by maintaining the machine at posture shown in the figure at the next.

- Machine posture for inspecting the hydraulic oil level

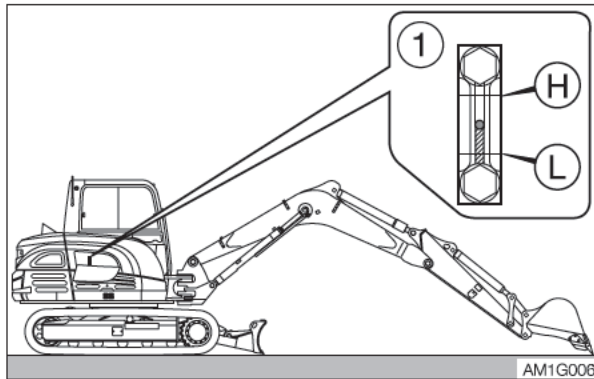

1. Start the engine and run it at low speed.
2. Fully retract the cylinders (arm and bucket), and lower the bucket to the ground.
3. Lower the dozer blade, and then stop the engine.
4. Open the fuel lid.
5. Inspect the oil level using the sight gauge (1).
 - When the oil temperature is about 20°C (68°F):
The level should be between the upper limit (H) and the lower limit (L).
If it is below the lower limit (L), replenish.
 - When the oil temperature is about 50 to 80°C (122 to 176°F):
The level should be slightly below the upper limit (H).

Replenishing

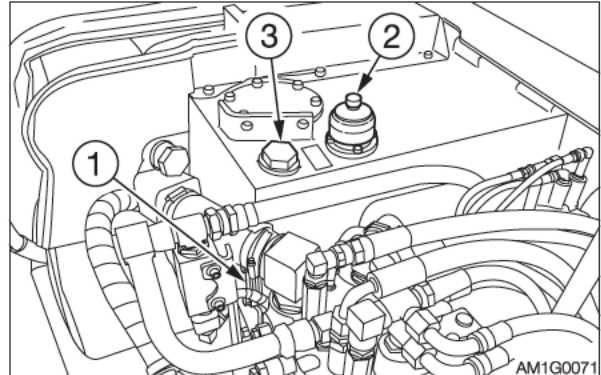

IMPORTANT: Do not fill up to the level higher than the upper limit (H). It will damage the hydraulic circuits or result in oil spurting. If accidentally done, stop the engine and wait the hydraulic oil to cool, and then let the excessive oil to drain from the drain plug.

1. Open the side cover.
2. Press the air breather button (2) to relieve the internal pressure from the tank.
3. Remove the plug (3).
4. Add the hydraulic oil up to the middle point of the sight gauge (1).
5. Tighten the plug (3).



LUBRICATING THE WORKING EQUIPMENT

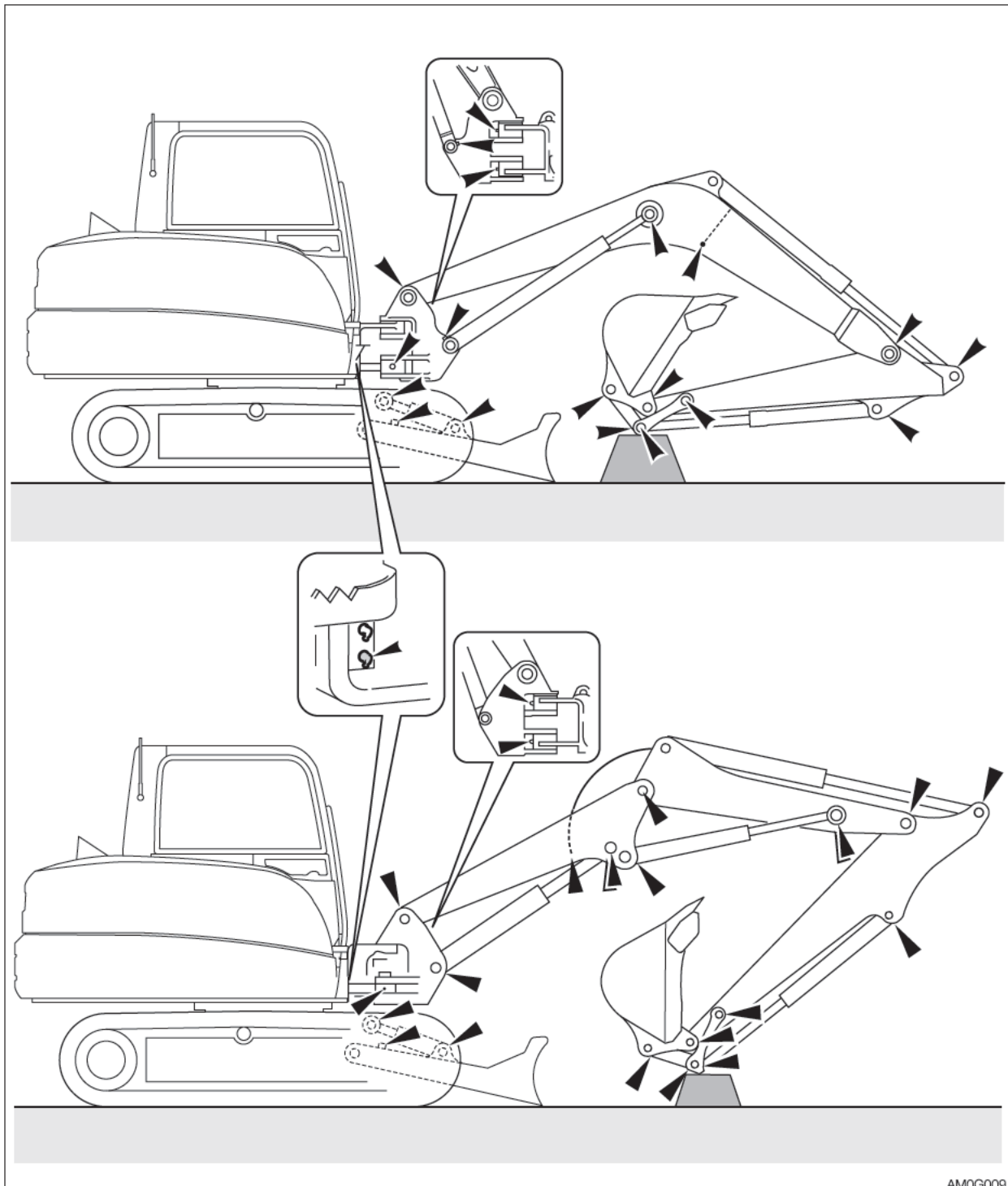

1. Keep the machine configuration as shown in the diagram above, lower the working equipment to the ground, and then stop the engine.
2. Use the grease gun to lubricate the grease fittings.
3. Wipe off the excess grease.



AFTER THE INITIAL 50 HOURS (ONLY FOR NEW MACHINES)

REPLACING THE ENGINE OIL AND THE OIL FILTER

WARNING

Stop the engine and allow the machine to cool down before performing maintenance.

- The engine, muffler, radiator, hydraulic lines, sliding parts and many other parts of the machine are hot immediately after the engine is stopped. Touching these parts will cause burns.
- The engine oil is also hot. Be careful not to touch the hydraulic oil when loosening the cap or plug. Working on the machine under these conditions could result in burns or injuries.

Engine oil

<TB285>

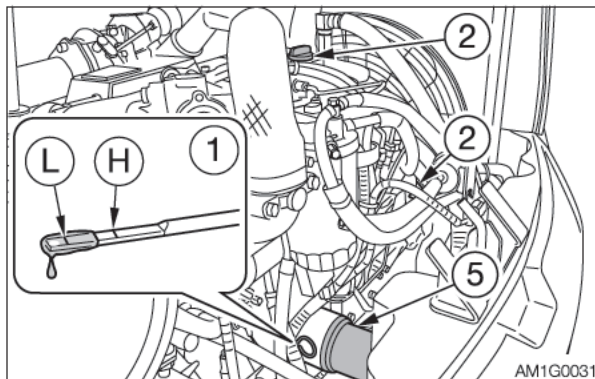

<TB290>

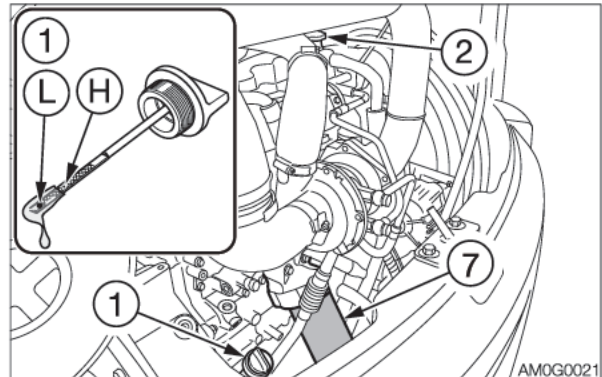

1. Open the engine hood and remove the oil filler cap (2).

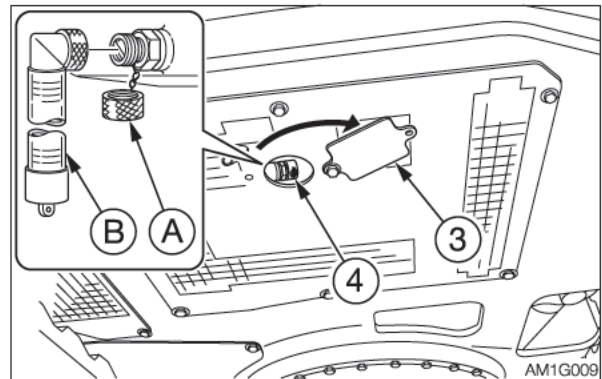

2. Loosen the bolts and remove the under cover (3).
3. Place a pan for catching the waste oil under the drain plug (4).
4. Remove the cap (A), install connector (B) and drain the oil. (The oil comes out when the screw is tightened.)
5. Remove the connector (B) and install the cap (A).

IMPORTANT: Check the waste oil for metal powder. If it contains large amounts of metal powder, consult your sales or service dealer.

**Engine oil filter****<TB285>**

6. Turn the filter (5) counterclockwise with the filter wrench and remove it.
7. Clean the surface of installation of the filter stand.
8. Apply a thin layer of oil on the packing of the new filter.
9. Install the new filter by hand.
10. Tighten one more turn (with the filter wrench) after the filter packing comes in contact with the surface of installation. (Torque when tightening with filter wrench: 19.6 to 23.5 N·m or 14 to 17 ft·lb.)
11. Add oil up to between the upper limit (H) and the lower limit (L) of the dipstick (1). Problems could arise if the oil level is either too low or too high. It takes around 10 minutes for all of the added oil to go down to the oil pan.
12. Tighten the oil filler cap (2).
13. Start the engine, run it at low idle for about 5 minutes, then stop it.
14. After about 10 minutes, inspect the oil level.

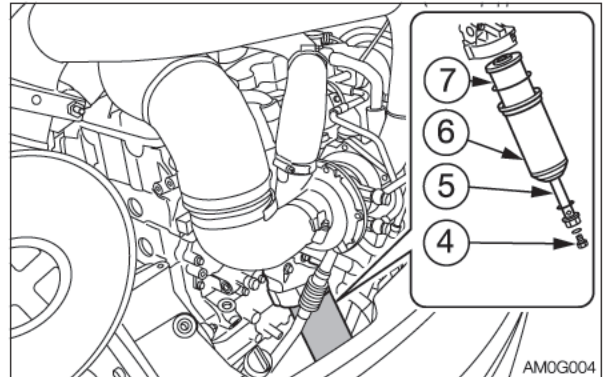
<TB290>

6. Place a pan for catching the waste oil under the engine oil filter.
7. Remove the drain plug (5) and drain the oil from the filter case (7).
8. Loosen the bolt (6) and remove the filter case (7).
9. Clean the inside of the filter case (7) and install a new element (8).
10. Clean the surface to install the filter stand and coat the new O-rings with thin oil.
11. Install the case (7) and secure it with the bolt (6).
 - Tightening torque: 44.1 N·m (32.5 ft·lb.)
12. Install the drain plug (5).
 - Tightening torque: 24.5 N·m (18.1 ft·lb.)
13. Add oil up to between the upper limit (H) and the lower limit (L) of the dipstick (1). Problems could arise if the oil level is either too low or too high. It takes around 15 minutes for all of the added oil to go down to the oil pan.
14. Tighten the oil filler cap (2).
15. Start the engine, run it at low idle for about 5 minutes, and then stop it.
16. After about 15 minutes, inspect the oil level.



INSPECTING AND ADJUSTING THE FAN BELT

WARNING

Stop the engine and allow the machine to cool down before performing maintenance.

- The engine, muffler, radiator, hydraulic lines, sliding parts and many other parts of the machine are hot immediately after the engine is stopped. Touching these parts will cause burns.

IMPORTANT: The loose belts could result in bad battery charge, overheat of engine or early wear of belt. Too tight belts could damage the water pump or bearing and belt used to drive the alternator.

IMPORTANT: Do not let any oil or grease get on the belt.

Inspection

1. Open the engine hood.

<TB285>

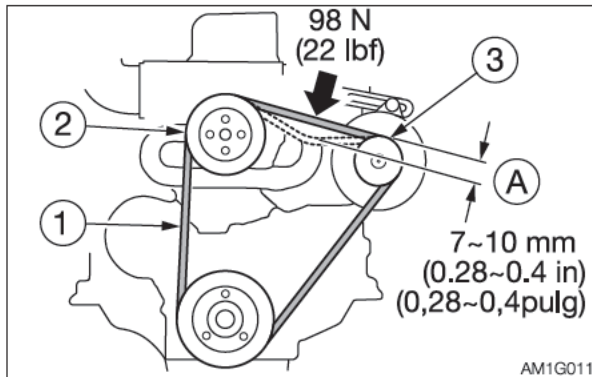

<TB290>

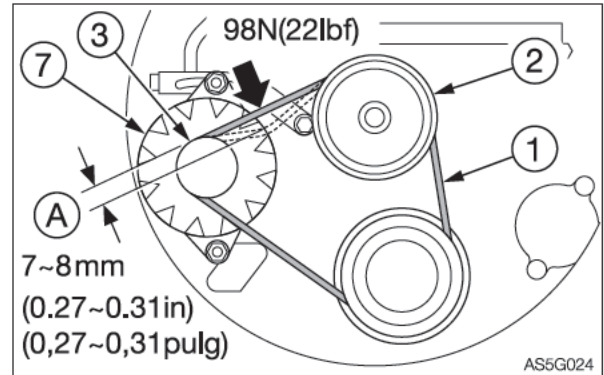

2. Press the fan belt (1) at the midpoint between the fan pulley (2) and alternator pulley (3) to check the tension (approx. 98 N or 22 lbf).

<TB285>

The slack (A) should be 7 to 10 mm (0.28 to 0.4 in).

<TB290>

The slack (A) should be 7 to 8 mm (0.27 to 0.31 in).

3. Inspect the fan belt (1) and replace if it is as follows.

- There are cuts or cracks.
- The belt is worn and touches the bottom of the V groove in the pulley.
- The belt stretched too loose to be adjusted.



Adjustment <TB285>

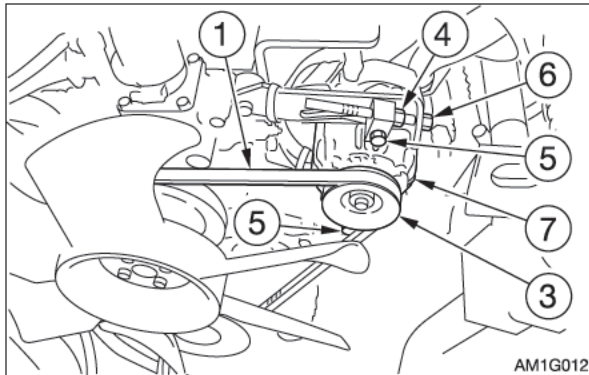

<TB290>

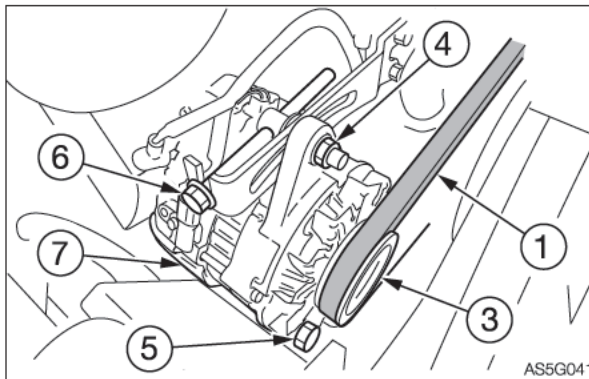

1. Loosen the bolt (5) and locking nut (4).
2. Turn the adjustment bolt (6) to move the alternator (7) and to adjust the tension of the fan belt (1).
 - Tighten: Clockwise
 - Loosen: Counterclockwise
3. Tighten the bolt (5) and locking nut (4).
Tightening torque:
<TB290>
 - Locking nut (4) 25 N·m (18.1 ft-lb.)
 - Bolt (5) 51N·m (37.6 ft-lb.)

Note: When replacing with a new belt, run the engine at low idle speed for about 3 to 5 minutes to break in the new belt, before adjusting the tension.



INSPECTING AND ADJUSTING THE COMPRESSOR BELT (AC)

WARNING

- Stop the engine and allow the machine to cool down before performing maintenance.
 - The engine, muffler, radiator, hydraulic lines, sliding parts and many other parts of the machine are hot immediately after the engine is stopped. Touching these parts will cause burns.
- The high-pressure pipes of the air conditioner can be very hot (80 to 120°C or 176 to 248°F). Be careful not to burn yourself.

IMPORTANT: Do not let any oil or grease get on the belt. It will cause the belt to slip, decrease the cooling capacity or shorten the service life of the air conditioner.

If the belt is too slack, it will slip and vibrate, resulting in decreased cooling capacity. The service life of the air conditioner also will be shortened. Adjust the belt tension to the standard value.

For TB285, 294 to 392 N or 66 to 88 lbf.
For TB290, 432.2 to 449.8 N or 97.2 to 101.1 lbf

<TB285>

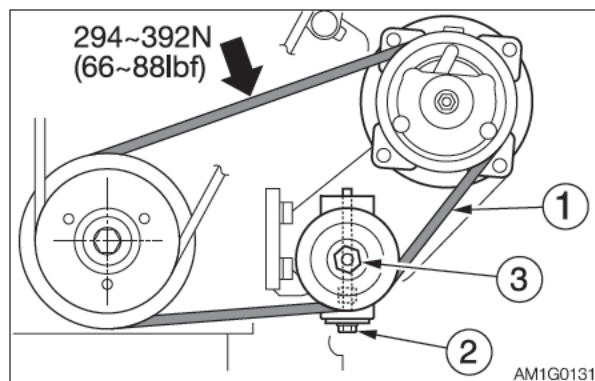

<TB290>

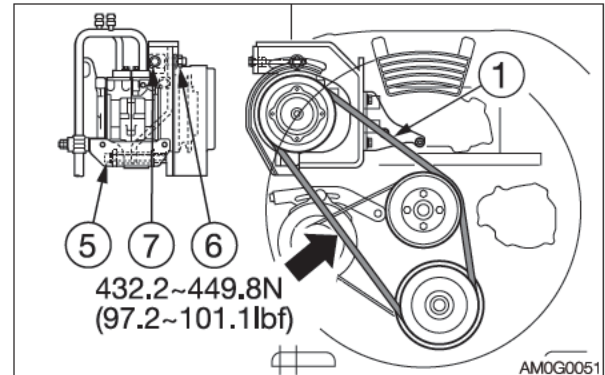

Inspection

<TB285>

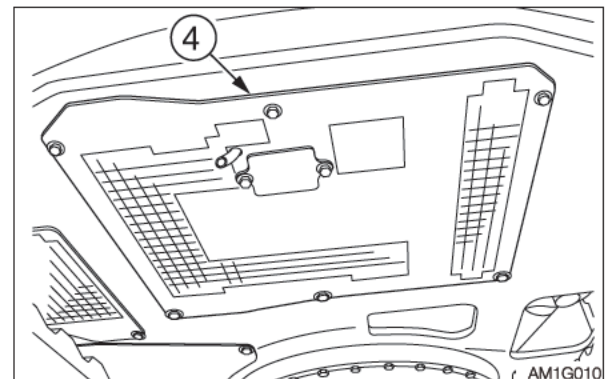

1. Loosen the bolts and remove the under cover (4). <TB285>

1. Open the engine hood. <TB290>

2. Measure the belt (1) tension using the belt tension gauge. The belt tension is normal if the belt tension gauge indicates the following values.

For TB285, 294 to 392 N or 66 to 88 lbf.

For TB290, 432.2 to 449.8 N or 97.2 to 101.1 lbf

**Adjustment****<TB285>**

If the belt tension is not normal, adjust it with the adjuster bolt (2).

1. Loosen the locking nut (3).
2. Turn the adjuster bolt (2) as follows.
 - Tighten: Clockwise
 - Loosen: Counterclockwise
3. Tighten the locking nut (3) after adjustment.

Tightening torque:

- Locking nut (4) 31.4 to 45.1 N·m (23.2 to 33.3 ft-lb.)

<TB290>

If the belt tension is not normal, tilt the compressor to adjust the tension.

1. Loosen the fixing bolt (5) and fixing nut (6).
2. Turn the adjuster bolt (7) as follows.
 - Tighten: Clockwise
 - Loosen: Counterclockwise
3. Tighten the fixing bolt (5) and fixing nut (6) upon completion of adjustment.

Note: When replacing with a new belt, run the engine at low idle speed for about 3 to 5 minutes to break in the new belt, before adjusting the tension again.

Replacing

Replace the belt in the following cases:

- There are cuts or cracks.
- The belt is worn and touches the bottom of the V groove in the pulley.
- The belt stretched too loose to be adjusted.



EVERY 50 HOURS

INSPECTING THE CRAWLER BELT TENSION

Note: This machine uses a hydraulic cylinder to adjust the tension of the crawler belts. It is not necessary to regularly perform adjustments of the crawler belt tension.

If the tension is too loose and the track comes off, the hydraulic cylinder is likely faulty. Ask your sales or service dealer for repairs.

MEMO



LUBRICATING THE SLEW BEARING

WARNING

Do not slew while lubricating. Doing so is dangerous, as you may get caught in the machine.

4. Lower the bucket to the ground, and then stop the engine.
5. Repeat the steps 2 to 4 above three times.
6. Wipe off the grease expelled from the slew bearing and grease fitting.

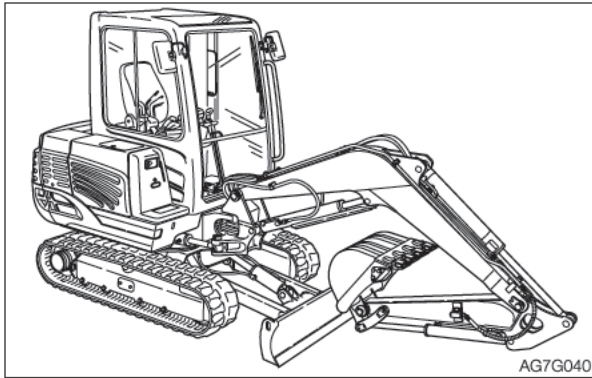

1. Stop the engine with the machine in the posture shown on the figure above.

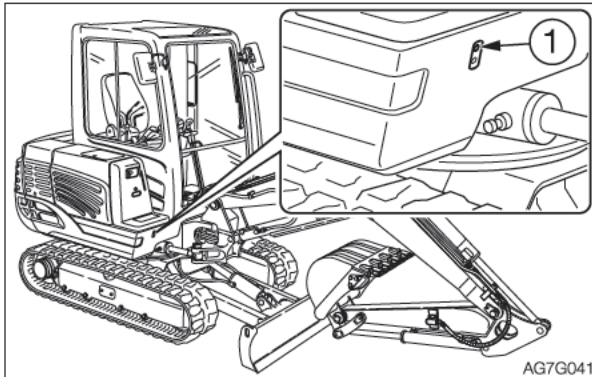

2. Use the grease gun to grease the grease fitting (1).

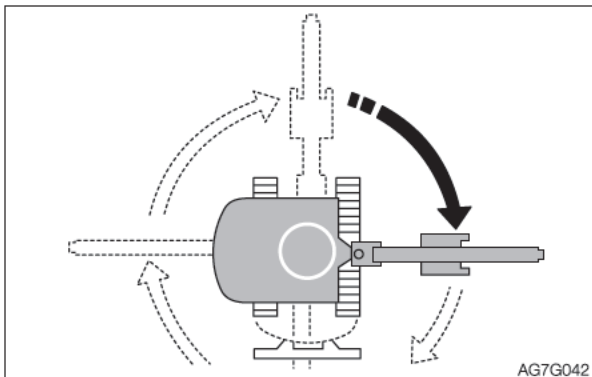

3. Start the engine, lift the bucket and slew clockwise 90°.



DRAINING THE WATER FROM THE FUEL TANK

WARNING

- Do not smoke or permit open flames while handling fuel or working on the fuel system.
- Never remove the fuel cap or add fuel when the engine is running or still hot. Do not spill fuel on the hot surface of the machine.
- Fill the fuel tank in a well ventilated place.
- Do not fill the fuel tank to capacity. Allow room for oil expansion.
- Clean up spilled fuel immediately.
- Securely tighten the fuel filler cap.
- Use the correct grade of fuel for the operating season.

Do the draining operation before starting the machine.

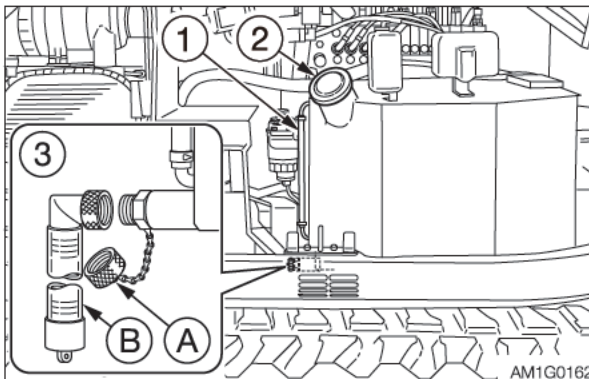

1. Open the side cover.
2. Remove the fuel filler cap (2).
3. Place a pan under the drain valve (3).
4. Remove the cap (A), install the connector (B), and then drain the water and sediment buildup in the bottom of the tank (the water comes out when the screw is tightened).
5. Remove the connector (B) and install the cap (A).
6. Add fuel while watching the sight gauge (1).
7. Tighten the fuel filler cap (2).
8. Close the side cover and lock it with the key.
9. Bleed air.

Bleeding air from the fuel system

Refer to “Bleeding air from the fuel system” on page 6-8.

Note: Air in the fuel system causes the engine to fail to start or to have problems. Bleed air when the fuel tank is emptied, using the same procedure above.



INSPECTING THE BATTERY FLUID LEVEL AND REPLENISHING

DANGER

- Do not use the battery when the fluid level is below the lower level limit. Doing so will hasten the deterioration of the internal portions of the battery and shorten the battery life. It also can cause rupturing (explosion).
- Batteries generate flammable hydrogen gas which may explode. Keep away from flame, sparks, fire or lighted cigarettes.
- Use a dampened cloth to clean above the fluid level line and check the fluid level. Do not clean with a dry cloth; otherwise it can cause static electricity to build up, resulting in ignition or explosion.

WARNING

- Wear protective goggles and clothing when working with batteries.
- Do not add the distilled water above the upper level limit. Doing so could cause the fluid to leak. This fluid can cause skin damage if contacted, or can cause the machine components to corrode.
- Batteries contain sulfuric acid which will damage eyes or skin if contacted.
 - If eye contact occurs, flush immediately with clean water and get prompt medical attention.
 - If accidentally swallowed, drink large quantities of water or milk and call a physician immediately.
 - If acid contacts skin or clothing, wash off immediately with a lot of water.

Inspection

IMPORTANT: Check the fluid level of all cells following the steps below, even when the fluid level can be checked using the indicator.

1. Open the engine hood.

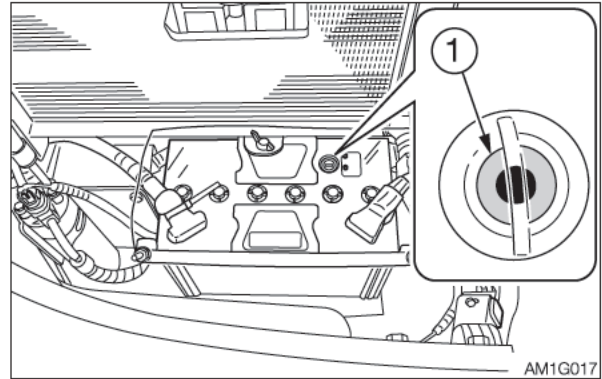

2. Inspect the indicator (1).
 - Blue: Good
 - White: Charging needed
 - Red: Insufficient battery fluid
3. Inspect the fluid level.

The fluid level must be between the upper level line (H) and lower level line (L). If not, add distilled water up to the line (H).



MAINTENANCE EVERY 50 HOURS

- If the fluid level cannot be checked by fluid level lines:

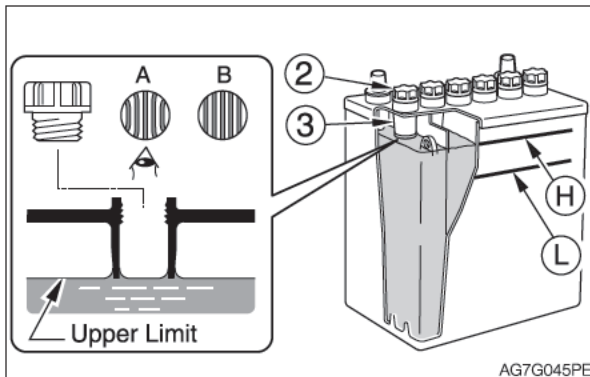

Remove the caps (2) and look into the fluid filler holes to check the fluid level. If the fluid is below the sleeve (3), be sure to add distilled water up to the bottom edge of the sleeve (3).

Proper level (A)

If the fluid reaches up to the bottom edge of the sleeve (3), the surface tension causes the fluid to swell and the plate appears as if it is distorted.

Level too low (B)

If fluid does not reach up to the bottom edge of the sleeve (3), the plate looks laminar, not distorted.

4. Check the terminals for looseness and dirt.

Replenishing

When adding distilled water, do so before starting operations in order to prevent freezing.

1. Remove the caps (2), and add distilled water until the upper level (H).
2. Check that the indicator (1) turns blue.
3. Clean the exhaust hole on the cap, then tighten the caps (2) securely.



AFTER THE INITIAL 250 HOURS (ONLY FOR NEW MACHINES)

REPLACING THE HYDRAULIC OIL RETURN FILTER

WARNING

- Stop the engine and allow the machine to cool down before performing maintenance.
 - The engine and the hydraulic system and many other parts of the machine are hot immediately after the engine is stopped. Touching these parts will cause burns.
 - The hydraulic oil is also hot and under high pressure.
Be careful not to touch the hydraulic oil when loosening the cap or plug.
Working on the machine under these conditions could result in burns or injuries due to the hot oil spurting out.
- Oil may spurt out if caps or filters are removed or pipes are disconnected before releasing the pressure in the hydraulic system.
 - Press the air breather button to relieve the internal pressure from the tank.
 - When removing plugs or screws, or when disconnecting hoses, stand to the side and loosen them slowly to gradually release the internal pressure before removing.

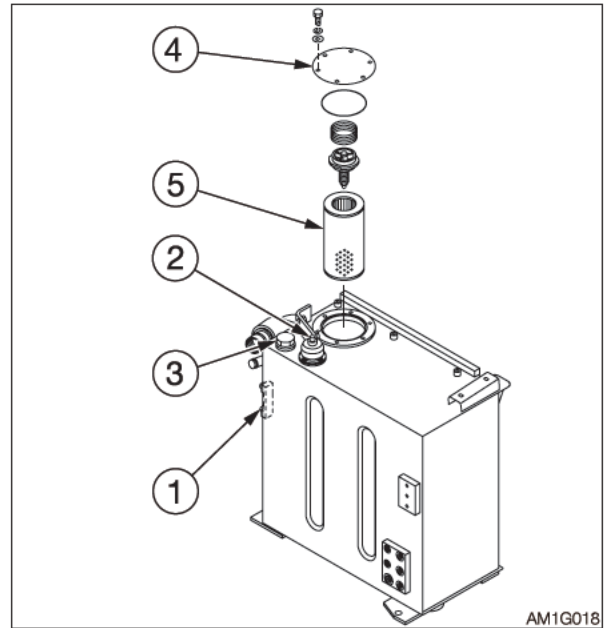

1. Open the side cover.
2. Press the air breather button (2) to relieve the internal pressure from the tank.
3. Loosen the bolts and remove the flange (4).
4. Remove the return filter (5).
5. Install a new return filter.
6. Install the flange (4) on its original position.
7. Inspect the level with the sight gauge (1), and replenish if the level is too low. Refer to "Inspect the hydraulic oil tank level and replenishing" on page 5-20.



REPLACING THE PILOT LINE FILTER

WARNING

- Stop the engine and allow each part of the machine to cool down before performing maintenance.
 - The engine, the hydraulic system and many other parts of the machine are hot immediately after the engine is stopped. Touching these parts will cause burns.
 - The hydraulic oil is also hot and under high pressure immediately after the engine is stopped. Be careful not to touch the oil when loosening the cap or plug. Working on the machine under these conditions could result in burns or injuries due to the hot oil spurting out.
- Oil may spurt out if caps or filters are removed or pipes are disconnected before releasing the pressure in the hydraulic system.
 - Press the air breather button to relieve the internal pressure from the tank.
 - When removing plugs or screws, or when disconnecting hoses, stand to the side and loosen them slowly to gradually release the internal pressure before removing.

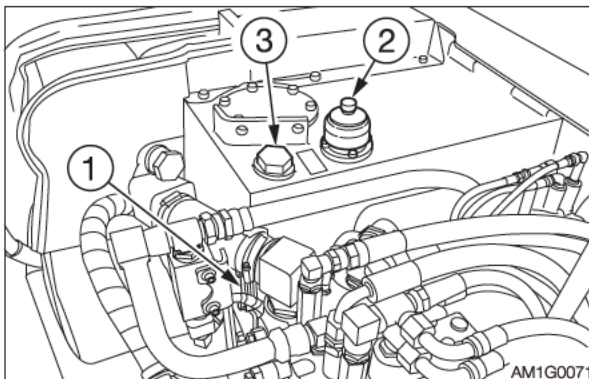

1. Open the side cover.
2. Press the air breather button (2) to relieve the internal pressure from the tank.

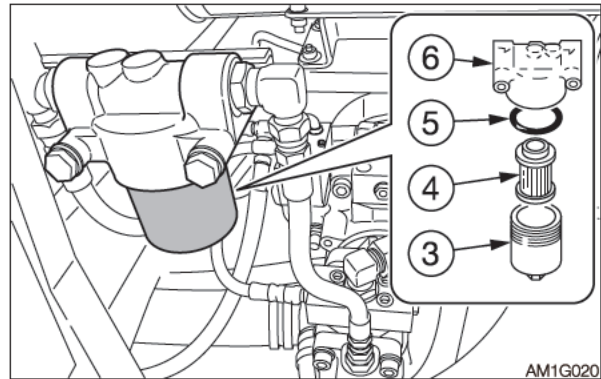

3. Open the engine hood.
4. Turn the case (3) counterclockwise and remove it.
5. Remove the element (4) and O-ring (5).
6. Clean the inside of the case (3).
7. Apply a thin layer of oil on the O-ring of the new filter.
8. Install the new element on the filter stand (6).
9. Apply a thin layer of oil on the new O-ring (5).
10. Install the new O-ring (5) and the case (3) on the filter stand (6).
11. Inspect the level with the sight gauge (1) and replenish if the level is too low. Refer to "Inspecting the hydraulic oil tank level and replenishing" on page 5-20.



REPLACING THE TRAVEL MOTOR GEAR OIL

WARNING

- Stop the engine and allow the machine to cool down before performing maintenance.
 - The travel motor is hot immediately after the engine is stopped. Touching it will cause burns.
 - The gear oil is also hot and under high pressure immediately after the engine is stopped.
Be careful when loosening the plugs. Working on the machine under these conditions could result in burns or injuries.
- The pressure in the reduction gear case of travel motor may cause oil or the plug to fly out. Loosen the plug slowly to release the pressure.

IMPORTANT: If the percentage of the traveling time within the total operating time is high, replace the gear oil earlier than the specified time.

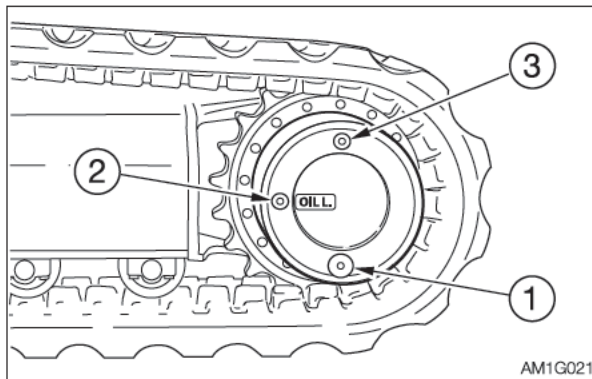

1. Set the travel motor so that plug (1) is at the very bottom.
2. Place a pan under the plug (1).
3. Remove the plugs (1), (2) and (3) and drain the oil.
4. Rewrap the plugs with new sealing tape.
5. Tighten the plug (1).
 - Tightening torque: 58.8 ± 9.8 N·m (43.4 \pm 7.2 ft-lb.)

6. Add oil through the hole of the plug (3) until oil flows out of the hole of the plug (2).
7. Tighten the plugs (2) and (3).
 - Tightening torque: 58.8 ± 9.8 N·m (43.4 \pm 7.2 ft-lb.)



EVERY 250 HOURS

REPLACING THE ENGINE OIL AND THE OIL FILTER

Refer to “Replacing the engine oil and the oil filter” on page 5-22.

INSPECTING AND ADJUSTING THE FAN BELT

Refer to “Inspecting and adjusting the fan belt” on page 5-24.

INSPECTING AND ADJUSTING THE COMPRESSOR BELT (AC)

Refer to “Inspecting and adjusting the compressor belt” on page 5-26.



CLEANING THE AIR CLEANER

WARNING

- Stop the engine and allow the machine to cool down before performing maintenance.
 - The engine, muffler, radiator and many other parts of the machine are hot immediately after the engine is stopped. Touching it will cause burns.
- Wear required appropriate equipment such as protective goggle and filter mask when using compressed air, as metal fragments or other objects can fly and cause serious injury.

IMPORTANT: Be careful not to scratch the element. Do not use an element if it is damaged.

IMPORTANT: When operating the machine in very dusty places, perform inspection and maintenance operations every day.

IMPORTANT: Be sure to install the element and dust cap securely. If not, dust could be drawn into the cylinder, damaging the engine.

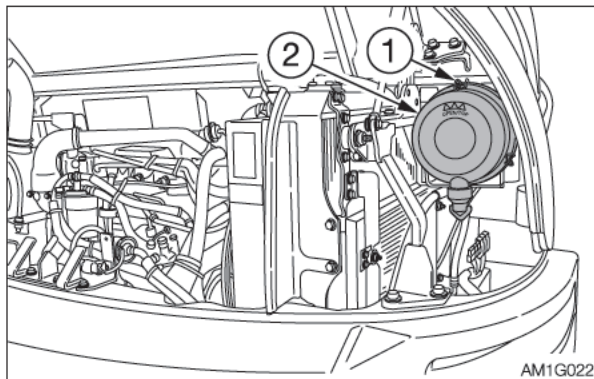

1. Open the engine hood.

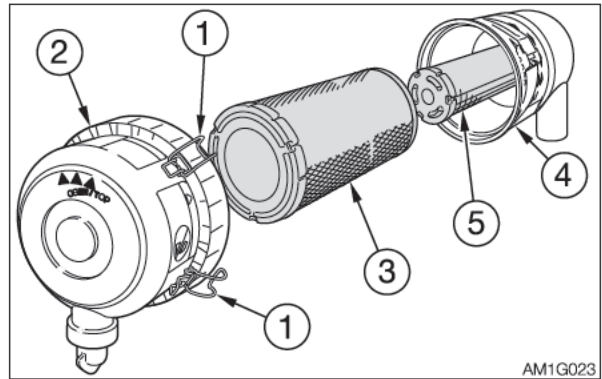

2. Loosen the clamps (1) and remove the dust cup (2).
3. Clean the inside of the dust cup (2).
4. Remove the primary element (3).
To prevent dirt from getting inside the engine, do not remove the secondary element (5).
5. Clean the inside of the body (4).

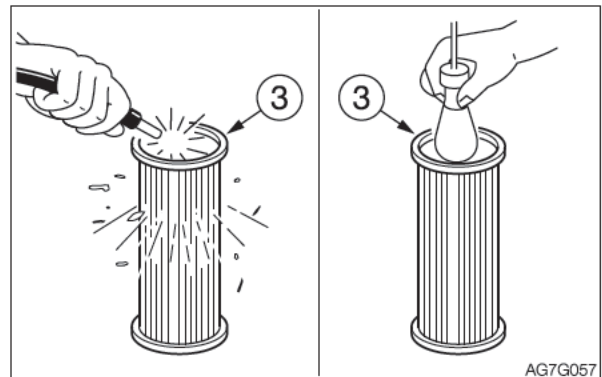

6. Clean the primary element (3) with dried compressed air (294 to 490 kPa or 43 to 71 psi).
First blow the air from the inside of the element along the pleats. Then blow the air from the outside and finally from the inside again.
7. Light up the inside of the primary element (3) with a light bulb, inspect it, and replace it if there are small holes or thin spots.
8. Install the primary element (3).
9. Install the dust cup (2) with its "▲▲▲ OBEN/TOP" mark facing up, and then fasten it with the clamps (1).



CLEANING THE RADIATOR FINS AND OIL COOLER FINS

WARNING

Wear required appropriate equipment such as protective goggles and filter mask when using compressed air, as metal fragments or other objects can fly and cause serious injury.

IMPORTANT: Be careful not to damage the fins when cleaning.

- When using compressed air or pressurized water, make sure the pressure is no higher than 200 kPa (28 psi) and hold the nozzle sufficiently away from the fins.

IMPORTANT: When using water, cover the electrical system to prevent water from getting in.

IMPORTANT: When operating the machine in very dusty places, perform inspection and maintenance operations every day.

2. Remove the screws (1) and open the condenser.
3. Blow compressed air on the fins to remove mud and dirt stuck on them.

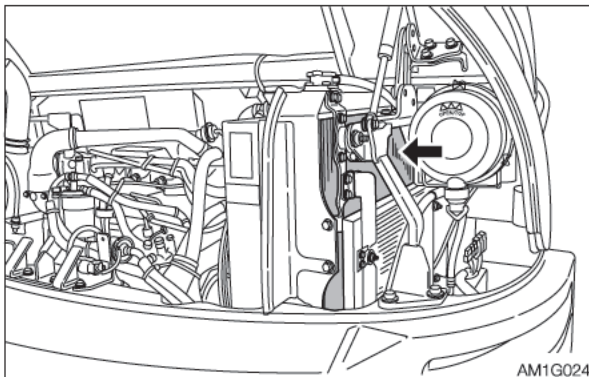

1. Open the engine hood.

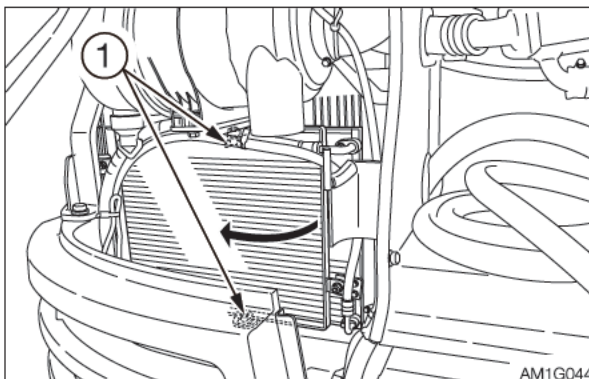



CLEANING THE AIR FILTERS (AIR CONDITIONER)

WARNING

Wear required appropriate equipment such as protective goggle and filter mask when using compressed air, as metal fragments or other objects can fly and cause serious injury.

Clean the filters immediately after operating in dusty places.

If the filters are clogged, the air flow is reduced and a booming sound is heard from the air conditioner unit.

Removing the filters

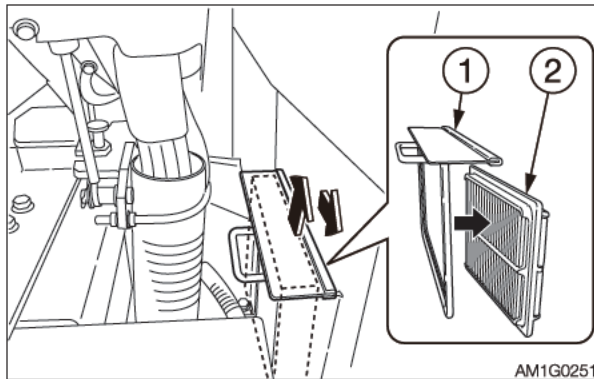

AM1G0251

1. Open the cab door.
2. Pull out the filter case (1) upward and remove the ventilation filter (2) from the filter case (1).

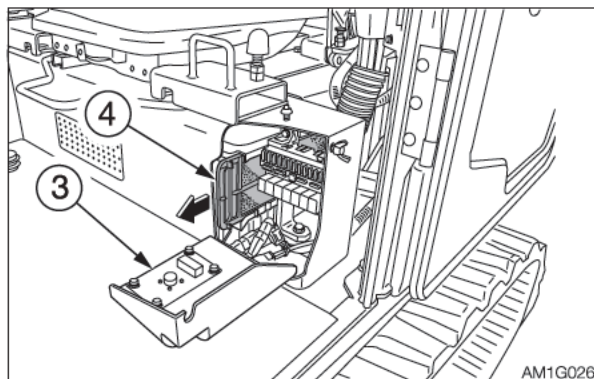

AM1G026

3. Open the cover (3).
4. Remove the circulation filter (4).
5. Use compressed air or water to clean the filters, depending on how dirty they are.

Cleaning

1. Blow dry, compressed air (138 kPa or 20 psi or less) directly on the filters from the inside, moving up and down along the pleats.
Be sure to keep the nozzle at an adequate distance from the filters.
2. Wash the filter with neutral detergent if it is very dirty. Dry the filter completely after washing it.



CLEANING THE CONDENSER (AC)

WARNING

Wear required appropriate equipment such as protective goggles and filter mask when using compressed air, as metal fragments or other objects can fly and cause serious injury.

IMPORTANT: Be careful not to damage the fins when cleaning.

- When using compressed air or pressurized water, make sure the pressure is no higher than 200kPa (28 psi) and hold the nozzle sufficiently away from the fins.

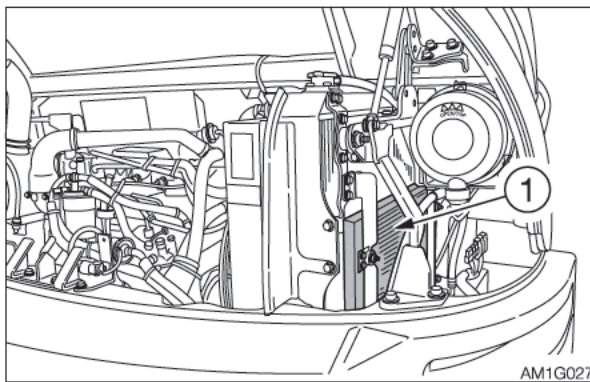

1. Open the engine hood.
2. Clean the condenser (1).



INSPECTING THE REFRIGERANT (GAS) LEVEL (AC)

WARNING

- Exposure of the eyes or hands to the cooler's refrigerant could result in blindness or frostbite. Never touch the refrigerant or loosen the parts of the cooling circuit.
- Keep flames away if the refrigerant gas is leaking.
- The high-pressure pipes of the air conditioner can be very hot (80 to 120°C or 176 to 248°F). Be careful not to burn yourself.

The cooling capacity decreases if the amount of refrigerant is insufficient. Inspect the refrigerant level using the sight glass (2) on the top of the receiver drier (1).

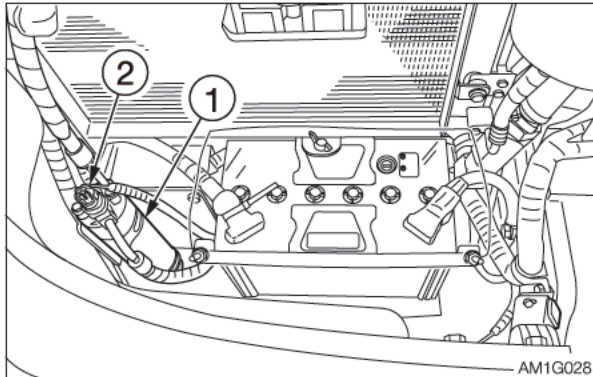

1. Open the engine hood.
2. Inspect the places for the conditions below.

Places for inspection	Conditions
Cab door	Fully open
Temperature control dial	Set fully to the COOL side
Fan speed	High
Ventilation / Circulation select switch	Circulation
Engine speed	Maximum speed
Air conditioner switch	ON

3. Inspect the refrigerant by watching the flow of air bubbles through the sight glass (2). Refer to "Check list for refrigerant volume" on page 5-43.

<TB285>

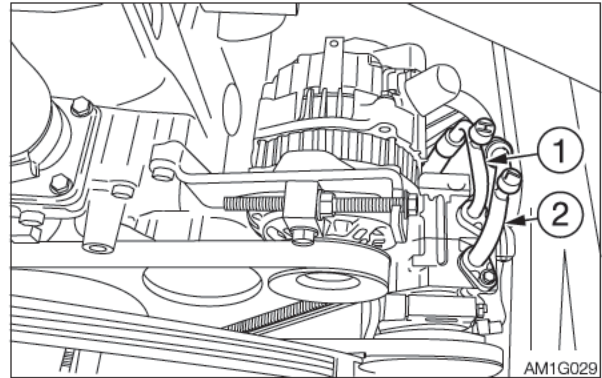

<TB290>

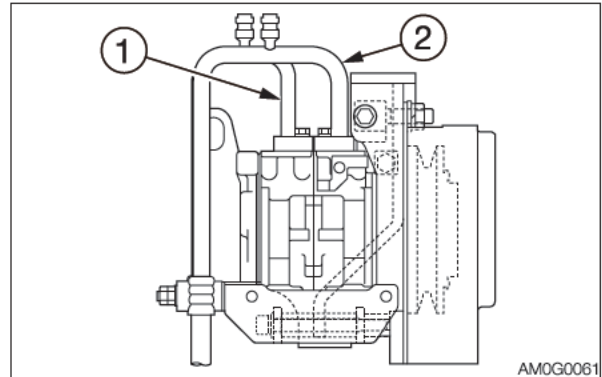

4. Check the temperature of the compressor's high pressure pipe (1) and low pressure pipe (2). Refer to "Check list for refrigerant volume" on page 5-43.

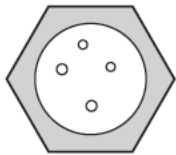
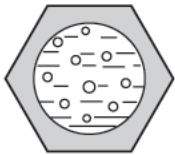
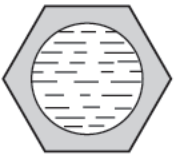
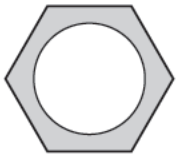

Check list for refrigerant volume

Air conditioner	Normal	Abnormal		
High/low pressure pipe temperature	High pressure pipe is hot (80 to 120°C or 176 to 248°F), low pressure pipe is cold (8 to 15°C or 46 to 59°F). Clear difference in temperature between the pipes.	High pressure pipe is warm, low pressure pipe is slightly cool. No significant difference in temperature between the pipes.	Little difference in temperature between the high-pressure pipe and the low-pressure pipe.	High pressure pipe is hot, low pressure pipe is slightly cool. A significant difference in temperature between the pipes.
Pipe connection	Normal	Some places are dirty with oil.	Some places are extremely dirty with oil.	Normal
Sight glass	 <p>AG7G064</p> <p>Almost transparent with some bubbles. Fully transparent when the engine speed is increased or decreased.</p>	 <p>AG7G065</p> <p>Flow of bubbles can be seen constantly. Sometimes transparent or white with bubbles.</p>	 <p>AG7G066</p> <p>Mist-like flow is faintly visible.</p>	 <p>AG7G067</p> <p>No bubbles is visible, even when the fan is set to High and the engine is idling.</p>
Refrigerant level	Proper level	Refrigerant may be leaking.	Refrigerant has leaked; little is left.	Refrigerant level too high

If the air conditioner is not working

If the air conditioner does not work well, set the fan switch to OFF and contact your sales or service dealer for inspection and/or repairs.

IMPORTANT: Continued use of the air conditioner when it is not working properly will damage its various parts.

IMPORTANT: Using the air conditioner when there is no refrigerant will damage the compressor.

IMPORTANT: Always consult your sales or service dealer for replacing the refrigerant. Be sure to use R134a refrigerant (740 to 820 g or 1.72 to 1.81 lb.).



EVERY 500 HOURS

REPLACING THE FUEL FILTER

WARNING

- Do not smoke or permit open flames while handling fuel or working on the fuel system.
- Stop the engine in a well-ventilated place and allow it to cool down before performing maintenance.
- Clean up spilled fuel immediately.

<TB285>

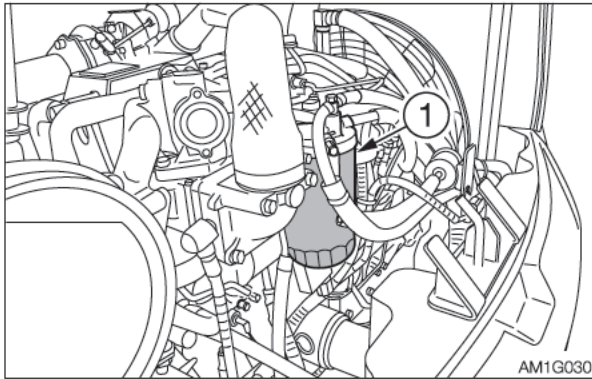

1. Open the engine hood.
2. Turn the filter (1) counterclockwise with the filter wrench and remove it.
3. Clean the surface of installation of the filter stand.
4. Apply a thin layer of oil on the packing of the new filter.
5. Install the new filter by hand.
6. Tighten one more turn after the filter packing comes in contact with the surface of installation. (Torque when tightening with filter wrench: 19.6 to 23.5 N·m or 14 to 17ft·lb.)
7. Bleed the air.
Refer to "Bleeding air from the fuel system" on page 6-8.

<TB290>

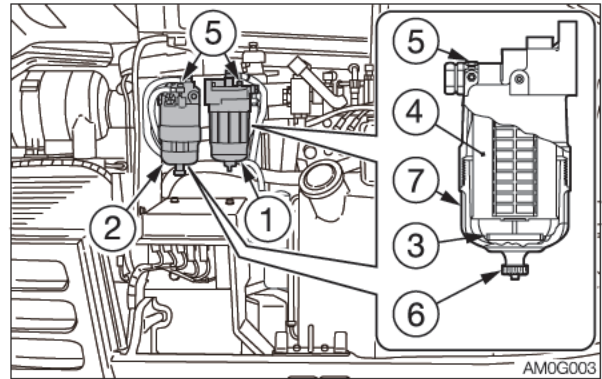

1. Open the side cover.

Pre-fuel filter

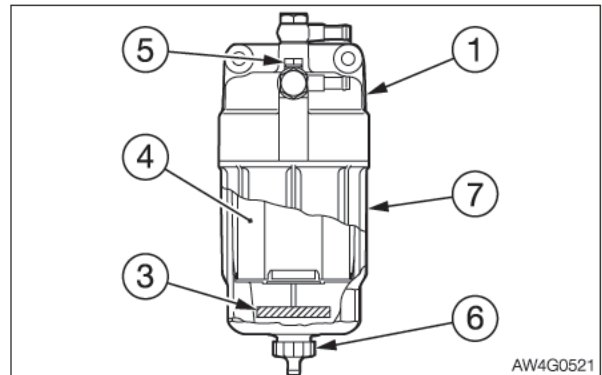

2. Place a pan under the pre-fuel filter (1) to catch fuel.
3. Loosen the vent plug (5) and the drain plug (6) to drain the fuel inside.
4. Remove the case (7) by using a filter wrench.
5. Replace the seals with new ones and lubricate the new seals with diesel fuel.
6. Put the new element (length of 150 mm / 5.9 in.) (4) in the case (7) and install by hand until the seal makes contact with the sealing surface.
7. Tighten the case (7) with the filter wrench.
Tightening torque: 30 N·m (22.1 ft·lb.)



Main fuel filter

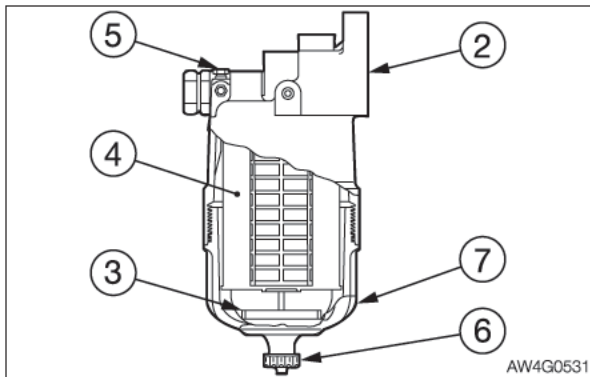

8. Place a pan under the main fuel filter (2) to catch fuel.
9. Loosen the vent plug (5) and the drain plug (6) to drain the fuel inside.
10. Remove the case (7) by using a filter wrench.
11. Replace the seals with new ones and lubricate the new seals with diesel fuel.
12. Put the new element (length of 131 mm / 5.2 in.) (4) in the case (7) and install by hand until the seal makes contact with the sealing surface.
13. Tighten the case (7) with the filter wrench.
Tightening torque: 29.4 N·m (21.7 ft-lb.)
14. Bleed air.
Refer to "Bleeding air from the fuel system" on page 6-8.



REPLACING THE WATER SEPARATOR FILTER <TB285>

WARNING

- Do not smoke or permit open flames while handling fuel or working on the fuel system.
- Stop the engine in a well-ventilated place and allow it to cool down before performing maintenance.
- Clean up spilled fuel immediately.

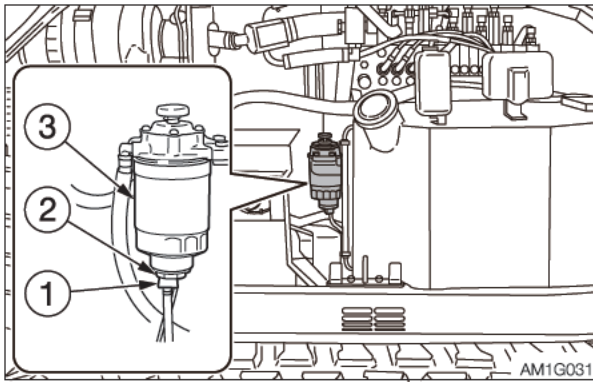

1. Open the side cover.
2. Place a pan for catching the waste oil under the drain hose.
3. Open the drain cock (1) and drain the fuel.
4. Remove the sensor (2).
5. Remove the filter (3).
6. Install the sensor (2) on the new filter.
7. Clean the surface to install the filter stand.
8. Apply a thin layer of oil on the packing of the new filter.
9. Install the new filter by hand
10. Tighten 2/3 more turn after the filter packing comes in contact with the surface of installation.
 - Tightening torque: 44.1 N·m (32.5 ft·lb.)
11. Bleed air.
Refer to “Bleeding air from the fuel system” on page 6-8.



REPLACING THE FEED PUMP FILTER <TB290>

WARNING

- Do not smoke or permit open flames while handling fuel or working on the fuel system.
- Stop the engine in a well-ventilated place and allow it to cool down before performing maintenance.
- Clean up spilled fuel immediately.

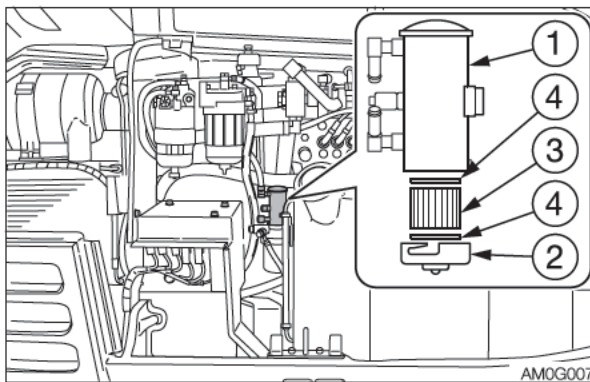

1. Open the side cover.
2. Place a pan under the feed pump (1) to catch fuel.
3. Remove the cover (2).
4. Remove the element (3) and gaskets (4).
5. Install the new element and gaskets.
6. Install the cover (2).
7. Bleed air.

Refer to “Bleeding air from the fuel system” on page 6-8.



EVERY 1000 HOURS

REPLACING THE HYDRAULIC OIL RETURN FILTER

Refer to “Replacing the hydraulic oil return filter” on page 5-34.

REPLACING THE PILOT LINE FILTER

Refer to “Replacing the pilot line filter” on page 5-35.

REPLACING THE TRAVEL MOTOR GEAR OIL

Refer to “Replacing the travel motor gear oil” on page 5-36.

CLEANING THE ENGINE COOLING SYSTEM

WARNING

- Stop the engine and allow the machine to cool down before performing maintenance.
 - The engine, muffler, radiator and many other parts of the machine are hot immediately after the engine is stopped. Touching these parts will cause burns.
 - The engine coolant is also hot and under high pressure immediately after the engine is stopped. Be careful when loosening the caps or plugs. Working on the machine under these conditions could result in burns or injuries due to the hot coolant spurting out.
- If maintenance must be performed with the engine running, always work as a two person team communicating each other.
 - One person must sit in the operator's seat so that he/she can immediately stop the engine when necessary. He/

she must take care not to touch the lever or pedal unless necessary.

- The one who performs maintenance must make sure to keep his/her body or clothing away from the moving part of the machine.
- Standing at the back of the machine while the engine is running is extremely dangerous, as the machine could move suddenly. Never stand at the back of the machine while the engine is running.
- Do not remove the radiator cap or the drain plug when the cooling water is hot. Stop the engine and wait until the engine and the cooling water cool. Then, slowly loosen the radiator cap and the drain plug to remove them.

When cleaning, if the temperature of the coolant is low, the thermostat will be closed and the coolant will not circulate in the radiator. Heat the coolant water to at least 90°C (194°F) before cleaning.

1. Open the engine hood and the side cover. <TB285>

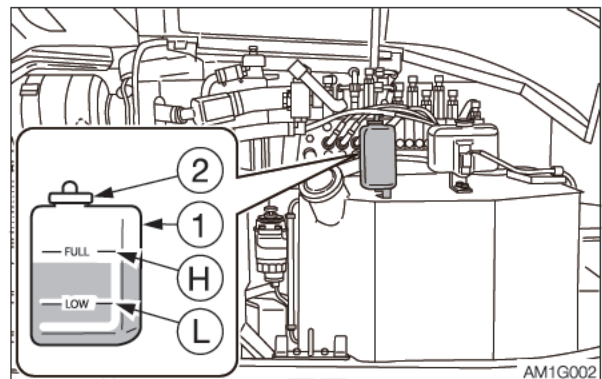

<TB290>

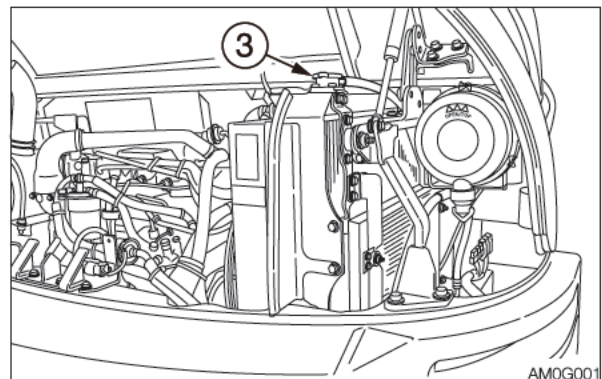



MAINTENANCE EVERY 1000 HOURS

2. Gradually loosen the radiator cap (3) to release the internal pressure, and then remove the cap.

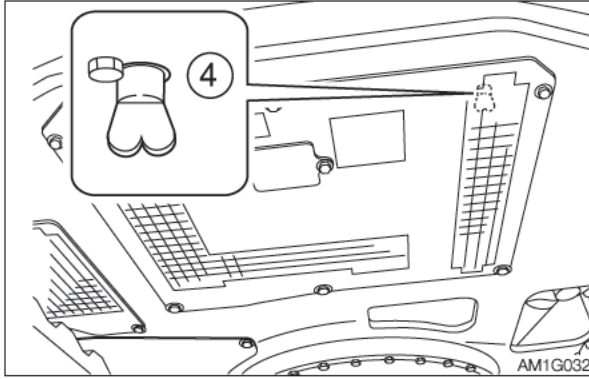

3. Place a pan for catching the waste coolant under the drain plug (4), and then loosen the drain plug (4) to drain the coolant.
4. Tighten the drain plug (4).
5. Add tap water to the radiator through the coolant fill port up to the top of the port. Take time and slowly add water, so that no air enters the radiator.
6. Close the radiator cap (3).
7. Start the engine and run it at a speed slightly above low idling. Raise the water temperature to at least 90°C (194°F), and then run the engine for about 10 minutes with the thermostat open.
8. Stop the engine, wait until the cooling water temperature becomes lower, and then remove the drain plug (4) to drain the water.
9. After draining, clean the cooling system using a cleaning agent. When using the cleaning agent, follow the instructions included with the agent.
10. Repeat the steps 4 to 8 to rinse the cooling system.
11. Tighten the drain plug (4).
12. Take time and slowly add the new coolant (mixture of antifreeze and tap water) to the radiator through the fill port until it is full.
13. Close the radiator cap (3).
14. Warm up the engine. Use the meters to check that there are no irregularities in the cooling system at this time.
15. Increase the water temperature to at least 90°C (194°F). Then, run the engine for about 10 minutes with the thermostat kept open.
16. Stop the engine, wait until the cooling water temperature becomes lower, and then check the level of coolant in the radiator.
If necessary, add cooling water until the radiator is full.
17. Close the radiator cap (3).
18. Clean the interior of the reserve tank (1), and then add coolant to the upper limit (H).
19. When the coolant has been replaced, inspect the coolant level once again after operating the machine.
Once the machine is operated, the coolant is distributed throughout the entire system, resulting in the lower coolant level.
Replenish the cooling water that has been used.



REPLACING THE AIR CLEANER ELEMENT

WARNING

Stop the engine and allow the machine to cool down before performing maintenance.

- The engine, muffler, radiator and many other parts of the machine are hot immediately after the engine is stopped. Touching these parts will cause burns.

IMPORTANT: Do not use an element if its pleats, gaskets or seals are damaged.

IMPORTANT: Be sure to install the element and dust cap securely. If not, dust could be drawn into the cylinder, damaging the engine.

7. Install the new elements. Press them firmly into the body (4).
8. Install the dust cup (2) with its “▲▲▲ OBEN/TOP” mark facing up, and then fasten it with the clamps (1).

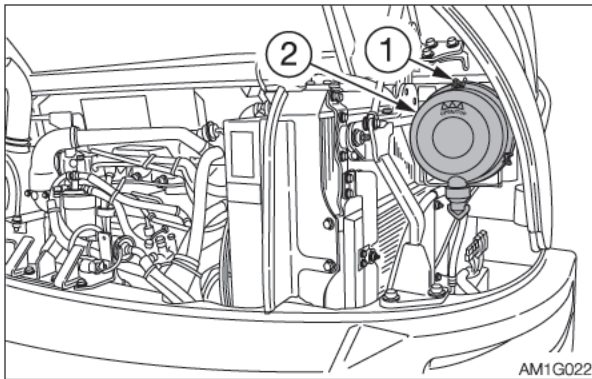

1. Open the engine hood.

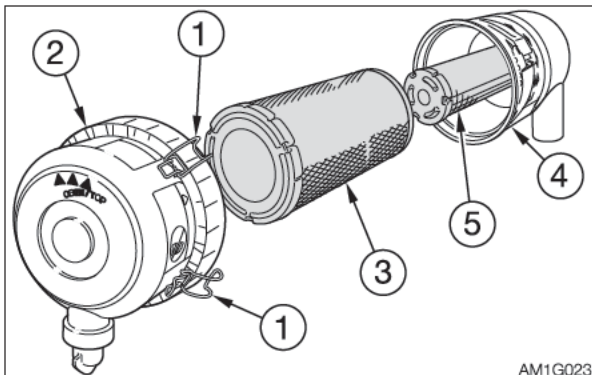

2. Loosen the clamps (1) and remove the dust cup (2).
3. Clean the inside of the dust cup (2).
4. Remove the primary element (3).
Do not remove the secondary element yet.
5. Clean the inside of the body (4).
6. Remove the secondary element (5).



REPLACING THE AIR BREATHER FILTER

WARNING

Oil may spurt out if caps or filters are removed or pipes are disconnected before releasing the pressure in the hydraulic system.

- Press the air breather button to relieve the tank pressure.

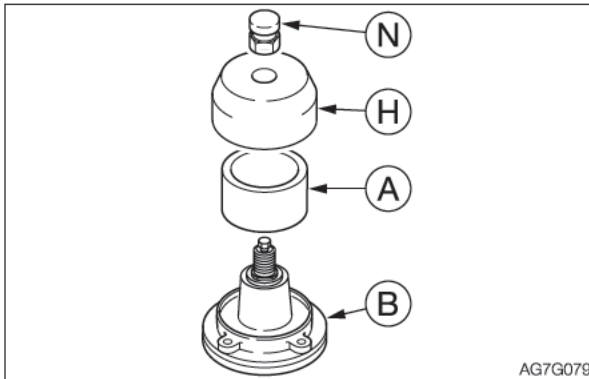

1. Open the side cover.
2. Press the button (N) to relieve the internal pressure from the tank.
3. Loosen the nut and remove the button (N) on the air breather.
4. Remove the cover (H).
5. Replace the filter (A).
6. Install the cover (H) on the body (B).
7. Install the button (N).

INSPECTING AND ADJUSTING THE ENGINE VALVE CLEARANCE

This operation requires experience. Ask your sales or service dealer for it.

RETIGHTENING THE ENGINE CYLINDER HEAD BOLT <TB285>

This operation requires experience. Ask your sales or service dealer for it.

INSPECTING THE ENGINE COMPRESSION PRESSURE <TB290>

This operation requires experience. Ask your sales or service dealer for it.

INSPECTING AND CLEANING THE ENGINE STARTER AND THE ALTERNATOR <TB290>

This operation requires experience. Ask your sales or service dealer for it.



EVERY 1500 HOURS

INSPECTING AND CLEANING THE ENGINE FUEL INJECTORS <TB285>

This operation requires experience. Ask your sales or service dealer for it.

INSPECTING THE CRANKCASE BREATHER SYSTEM <TB285>

This operation requires experience. Ask your sales or service dealer for it.



MAINTENANCE
EVERY 2000 HOURS

EVERY 2000 HOURS

LAPPING THE ENGINE VALVE SEATS <TB285>

This operation requires experience. Ask your sales or service dealer for it.



EVERY 4000 HOURS

REPLACING THE HYDRAULIC OIL AND CLEANING THE SUCTION STRAINER

WARNING

- Stop the engine and allow the machine to cool down before performing maintenance.
 - The engine and the hydraulic system and many other parts of the machine are hot immediately after the engine is stopped. Touching these parts will cause burns.
 - The hydraulic oil is also hot and under high pressure immediately after the engine is stopped. Be careful when loosening the caps or plugs. Working on the machine under these conditions could result in burns or injuries due to the hot oil spurting out.
- Oil may spurt out if caps or filters are removed or pipes are disconnected before releasing the pressure in the hydraulic system.
 - Press the air breather button to relieve the internal pressure from the tank.
 - When removing plugs or screws, or when disconnecting hoses, stand to the side and loosen them slowly to gradually release the internal pressure before removing.

1. Slew 45° clockwise and set the machine to the hydraulic oil level inspection posture. Refer to “Inspecting the hydraulic oil tank level and replenishing” on page 5-20.
2. Open the side cover.

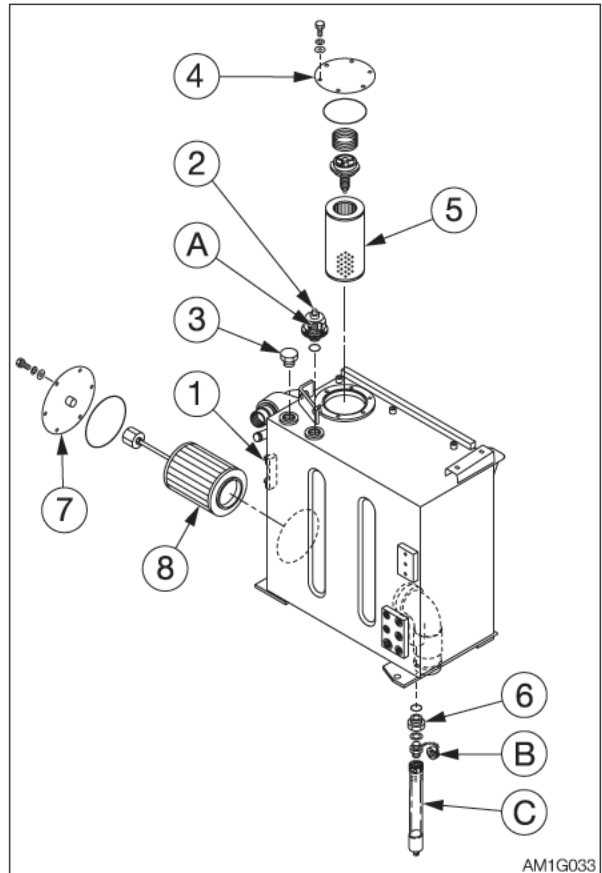

AM1G033

3. Press the button (2) to relieve the internal pressure from the tank.
4. Replace the air breather filter (A). Refer to “Replacing the air breather filter” on page 5-51.
5. Remove the plug (3).
6. Loosen the bolts and remove the flange (4).
7. Remove the return filter (5).
8. Place a pan under the plug (6) to catch the waste oil.
9. Remove the cap (B), install connector (C) and drain the oil. (The oil comes out when the screw is tightened.)

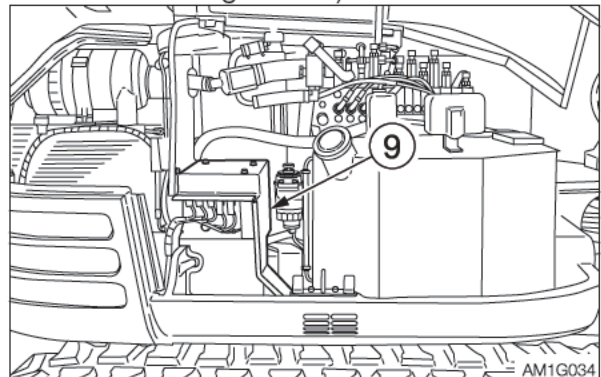

AM1G034



10. Remove the relay and fuse panel (9).
11. Loosen the bolts and remove the flange (7).
12. Remove the suction strainer (8) and clean it.
13. Clean the inside of the hydraulic tank.
14. Remove the connector (C) and install the cap (B).
15. Install the suction strainer (8) on the tank and then install the flange (7).
16. Install the new return filter (5) and the flange (4) on the tank.
17. Add hydraulic oil from the hole of plug (3) up to the level between the upper limit (H) and the lower limit (L) in the sight gauge (1).
18. Tighten the plug (3).
19. Install the relay and fuse panel (9).
20. Bleed air from the hydraulic oil circuit following "Bleeding air" below.
21. Set the machine to the hydraulic oil level inspection posture and inspect the oil level after the oil cools.
Refer to "Inspect the hydraulic oil tank level and replenishing" on page 5-20.

Bleeding air

IMPORTANT: After replacing the hydraulic oil, bleed air from the hydraulic circuits and hydraulic devices. Failure to do so may damage the hydraulic devices.

• Hydraulic pump

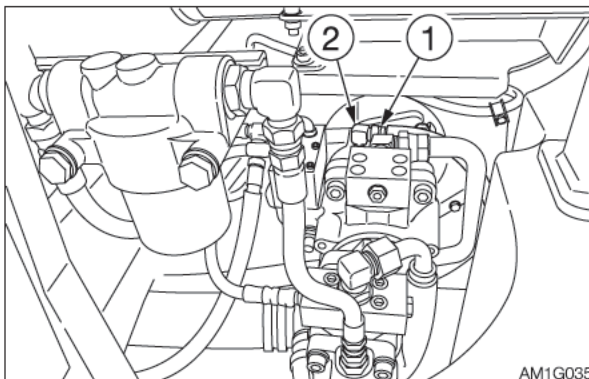

1. Open the engine hood.
2. Loosen the drain hose (1) of the hydraulic pump.

3. Tighten the drain hose (1) once there are no more air bubbles coming from the elbow (2) joint.

• Slew motor

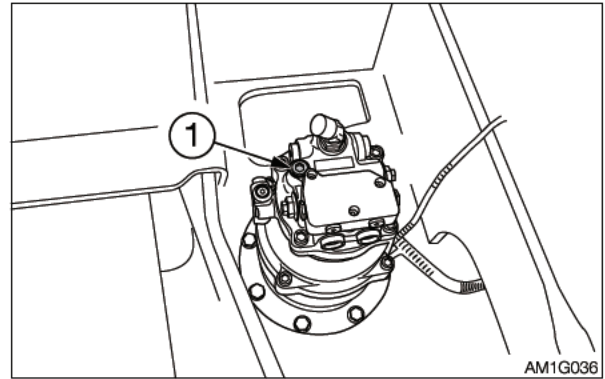

1. Loosen the air-bleeding plug (1).
2. Tighten the plug (1) once the hydraulic oil overflows from the air-bleeding plug hole (1).

• Cylinders

1. Start the engine, let it run at a low-idling speed for 10 minutes.
2. Maintain the engine at low idle, and then slowly extend and retract each cylinder 4 or 5 times, without letting them reach the stroke end.
3. While running the engine at high speed, slowly extend and retract each cylinder 4 or 5 times, without letting them reach the stroke end.
4. Return the engine speed to low idle, and then slowly extend and retract each cylinder 4 or 5 times to the stroke end.



**MAINTENANCE
EVERY 4000 HOURS**

This operation is dangerous and requires experience. Ask your sales or service dealer for help.

If air is not released, the working equipment could become slow in reacting to the operation of the operator and show unexpected behavior.

⚠ WARNING

When removing plugs or screws, or when disconnecting hoses, stand to the side and loosen them slowly to gradually release the internal pressure before removing.

• **Emergency shut-off valve**

1. Place a pan under the hose (A) or (B) to catch the waste oil.
2. Start the engine and run it at low idle.
3. Fully lower the safety lock lever to the unlock position.

Boom

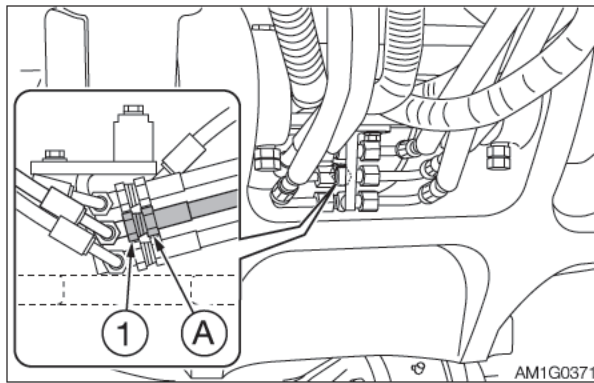

2-Piece boom

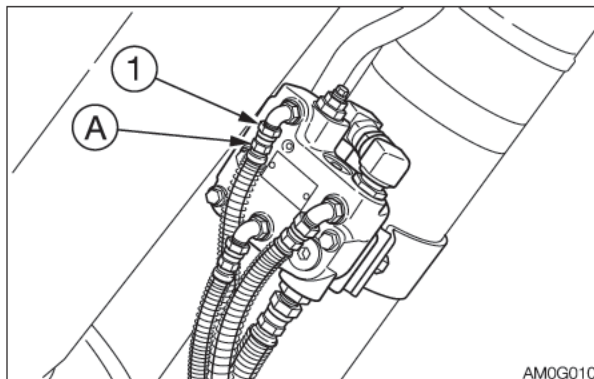

4. Hold the hose fitting (A) in place with a wrench and slowly loosen the hose nut (1).

5. Slowly move the boom in the “Boom lower” direction a little until there are no more air bubbles coming from the hose nut (1) joint.

6. Hold the hose fitting (A) in place with a wrench and tighten the hose nut (1).

Second boom

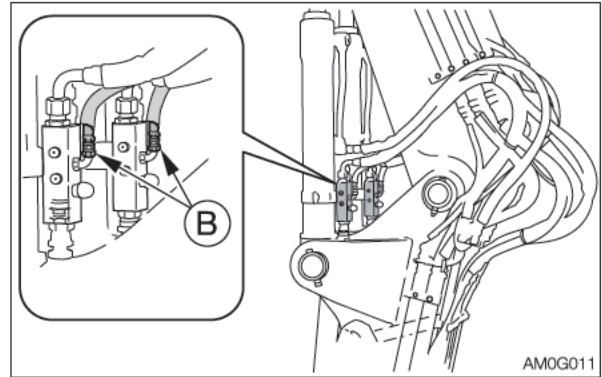

Arm

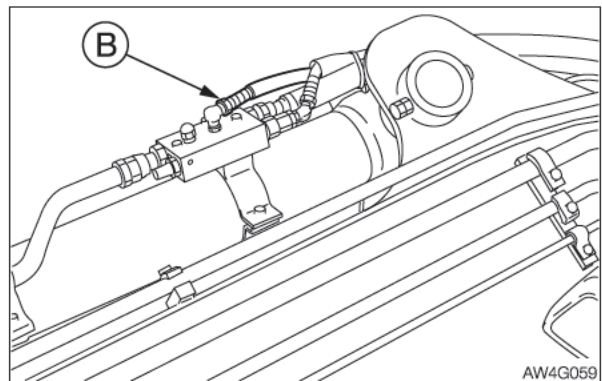

4. Loosen the hose (B) slowly.
5. Slowly move the arm in the “Arm in” direction a little until there are no more air bubbles coming from the hose (B) joint.
6. Tighten the hose (B).

MEMO



WHEN REQUIRED

REPLACING THE BUCKET TEETH AND THE SIDE CUTTERS

Replace the bucket teeth if the tooth points are worn. Do not wait until the bucket is damaged.

WARNING

- Before performing maintenance or repairs under the machine, lower all moveable working equipment to the ground or in the lowermost position.
- To prevent unexpected movement, firmly secure the working equipment when repairing or replacing the bucket teeth or side cutter.
- When using a hammer, pins may fly out or metal particles may be scattered. This may lead to serious injury.
 - If hard metal parts such as pins, bucket teeth, side cutter or bearings are hit with a hammer, wear protective gear such as safety goggles and gloves.
 - When hitting pins or bucket teeth, always check that there is no one in the surrounding area.
- Do not allow unauthorized personnel in the work area while working.

Removing

1. Clean the bucket and park the machine on a flat and rigid ground.

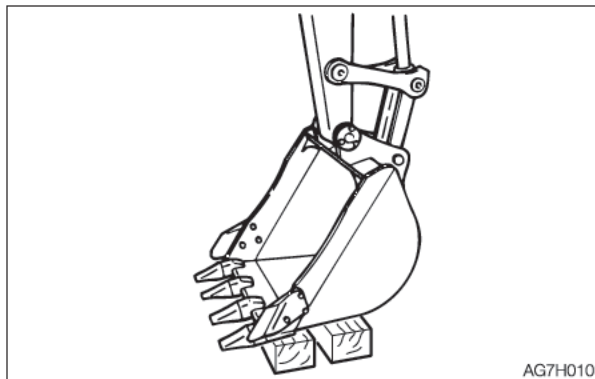

2. Place the bucket with its bottom flat on the blocks so that the locking pin can be knocked out.

3. Remove the key, and then check that the bucket is stable.

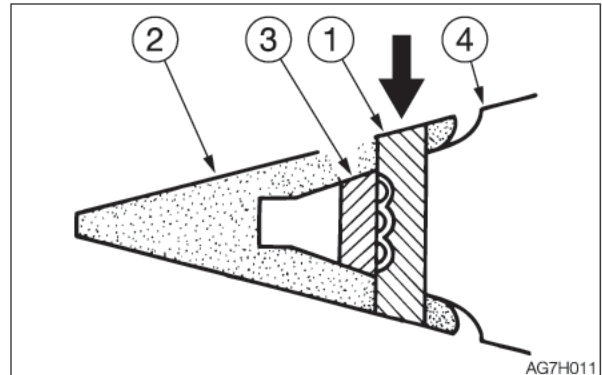

4. Knock out the locking pin (1) and remove the point (2).

Note: If the drift is set against rubber pin lock (3) when it is hit, the rubber pin lock may break. Set it against the back of the locking pin.

5. Remove the rubber pin lock (3). Check if the rubber pin lock is still usable. Replace it if it is as follows.

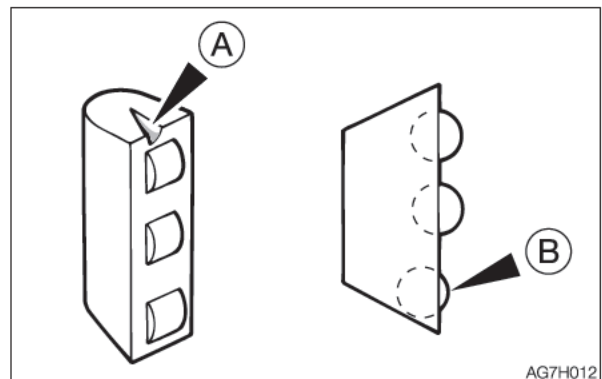

AThere are cracks in the rubber and the roller is coming off.

BThe roller is dented when pressed with a finger.



Installation

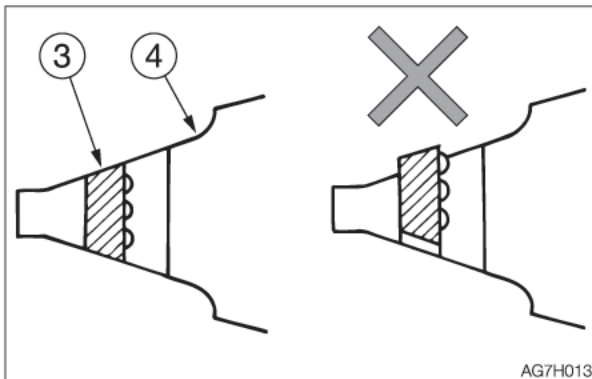

1. Remove the dirt on the surface of adaptor and the inner part of tooth, make the better contact on the mating part.
2. Push rubber pin lock (3) into the welding adaptor (4).
Do not let the rubber pin lock stick out from the welding adaptor surface.

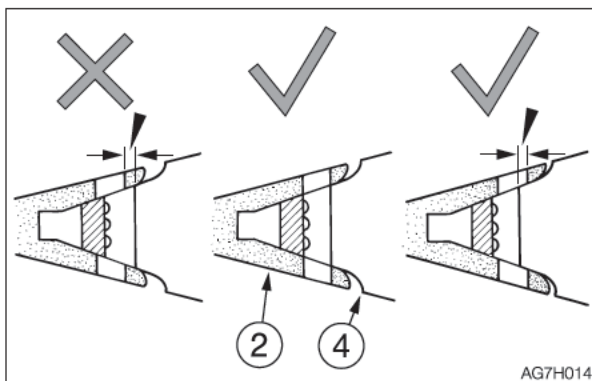

3. Install the point (2) onto the welding adaptor (4).
Insert the point so that the surface behind the point's pin hole is aligned with the surface behind the welding adapter's pin hole.

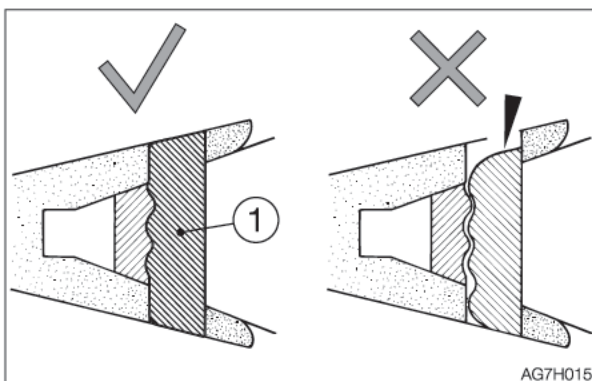

4. Knock out the locking pin (1).
Check that the end surfaces of the locking pin just knocked out are aligned with the upper and lower surface of the point. Do not use the worn locking pin.
The life of the teeth can be lengthened and the frequency of its replacement can be reduced by turning it upside down so that it will wear evenly.
Replace the rubber pin lock and locking pin at the same time as replacing the teeth. This makes it possible to prevent the teeth from falling out

**• Side cutter
Installation**

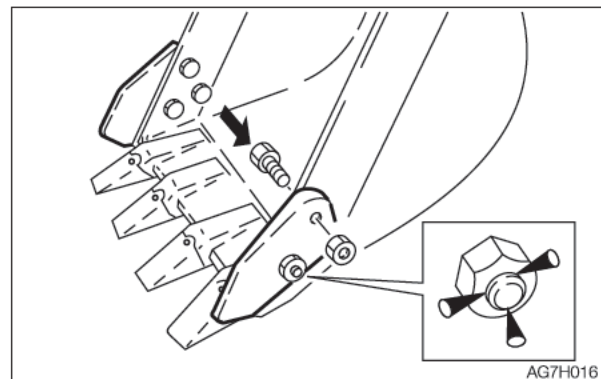

1. Insert the bolts from the inner of the bucket and tighten the side cutter with nuts.
Tightening torque: 475 N·m (350 ft·lb.)
2. Caulk the bolts with a punch at three spots along the periphery of the screw to prevent the nuts from coming loose.



REPLACING THE BUCKET

WARNING

- Before performing maintenance or repairs under the machine, lower all working equipment to the ground or in the lowermost position.
- If maintenance must be performed with the engine running, always work as a two person team communicating each other.
 - One person must sit in the operator's seat so that he/she can immediately stop the engine when necessary. He/she must take care not to touch the lever or pedal unless necessary.
 - The one who performs maintenance must make sure to keep his/her body or clothing away from the moving part of the machine.
- When using a hammer, pins may fly out or metal particles may be scattered. This may lead to serious injury.
 - If hard metal parts such as pins, bucket teeth, side cutter or bearings are hit with a hammer, wear protective gear such as safety goggles and gloves.
 - When hitting pins or bucket teeth, always check that there is no one in the surrounding area.
- When aligning the pin holes, always do so by checking them visually. Do not insert your finger in the pin hole, or you could lose your finger.

Removing

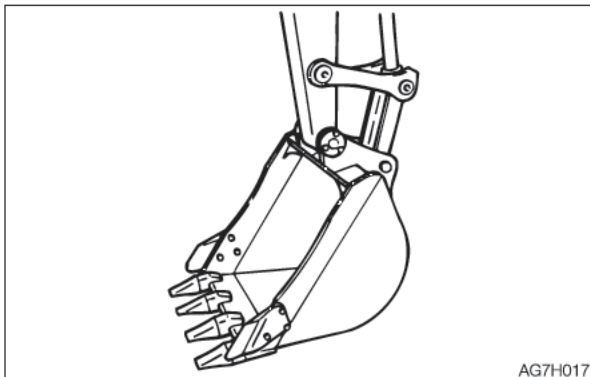

1. Lower the bucket to the ground as shown on the figure above in a stable position.

Note: When removing pins, set the bucket so that it is barely touching the ground. If the bucket is firmly touching the ground, the resistance will be great and it will be difficult to remove the pin.

2. Set the safety lock lever to the locked position and stop the engine.

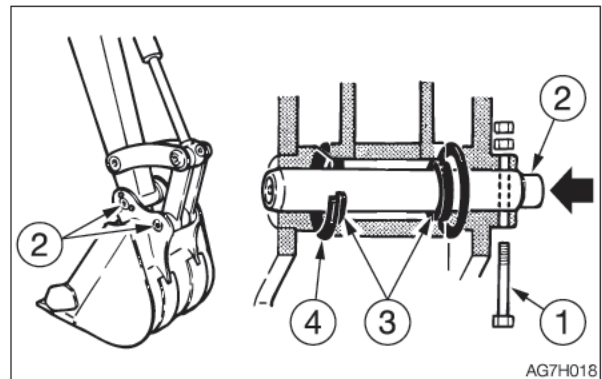

3. Remove the bolt (1).
4. Hammer the pin (2) out of the bucket.
5. Remove the bucket.
Inspect the pin seal (3) and replace it if it is deformed or damaged. (See next page.)



Installation

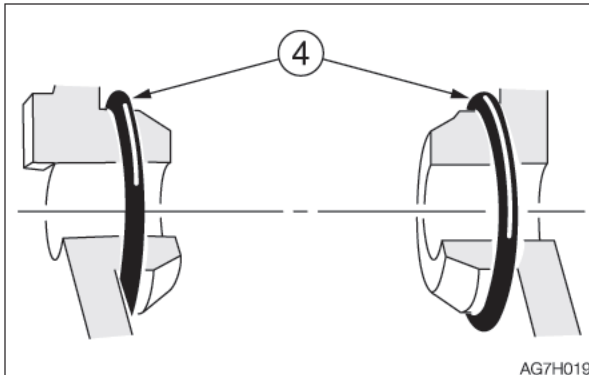

1. Set the O-ring (4) on the bucket as shown on the figure above.

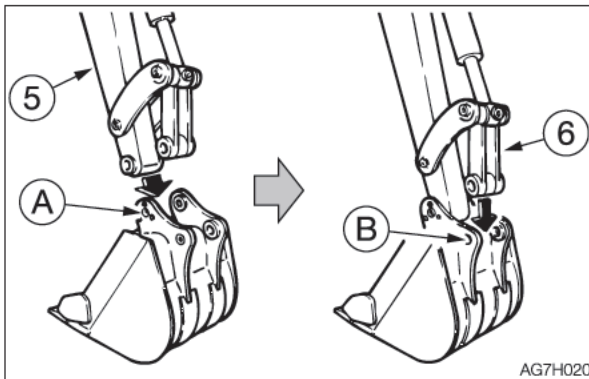

2. Align the pin hole (A) on the bucket with the pin hole on the arm (5), and install the pin (2).
3. Operate the cylinder, align the pin hole (B) on the bucket with the pin hole on the link arm (6), and install the pin (2).

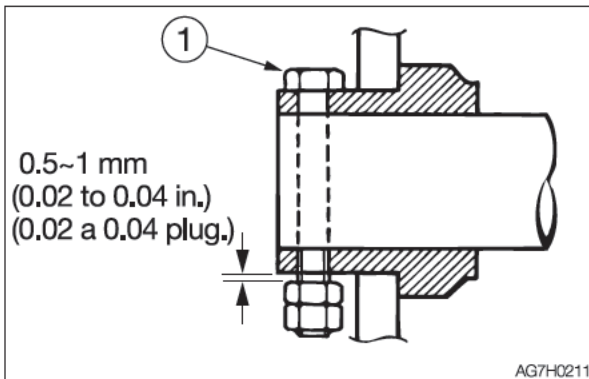

4. Align the turn prevention holes, and then install the bolt (1) and the nut. Be sure to leave a gap of about 0.5 to 1 mm (0.02 to 0.04 in.) between the nut and bucket bush, or the nut will come loose.

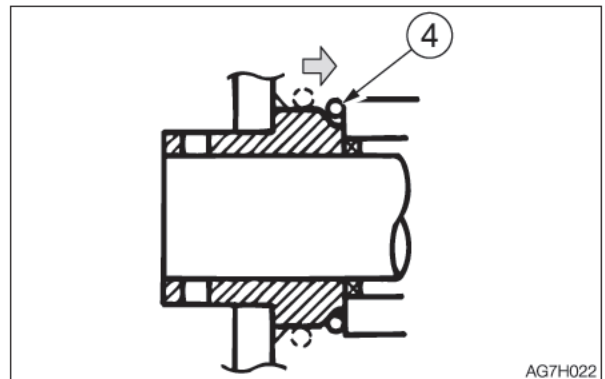

5. Adjust the gap between the bucket and the arm.
Refer to "Adjusting the gap between the bucket and arm (If equipped)" on page 5-62.
6. Slide the O-ring (4).

Replacing the pin seal

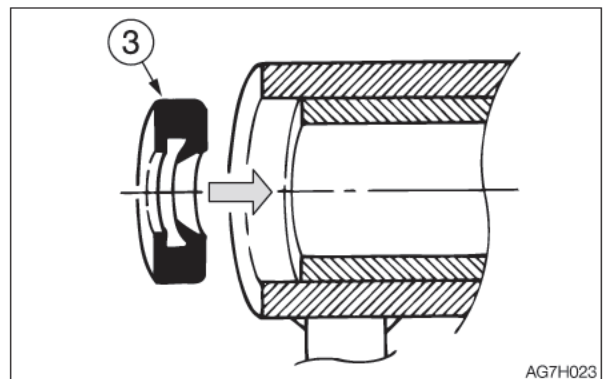

1. Set the pin seal (3) in the direction shown on the figure above.
2. Use a mallet to slowly press the pin seal in. Be careful not to damage the seal.



ADJUSTING THE GAP BETWEEN THE BUCKET AND ARM (IF EQUIPPED)

WARNING

- Before performing maintenance or repairs under the machine, lower all working equipment to the ground or in the lowermost position.
- To prevent unexpected movement, securely block the working equipment when adjusting the gap.

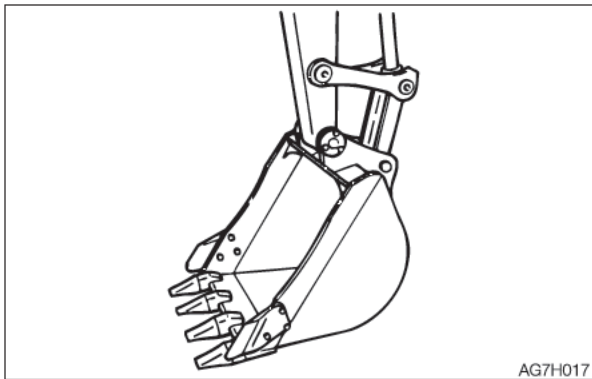

1. Lower the bucket to the ground as shown on the figure above in a stable position.
2. Check that the bucket does not move, and then set the safety lock lever to the locked position and stop the engine.

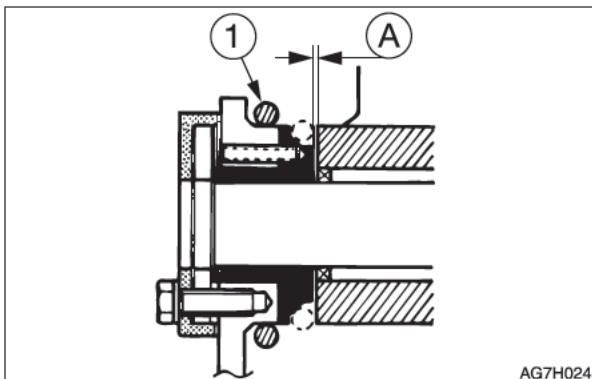

3. Move the O-ring (1) to bring the gap (A) into view and measure the width of the gap (A).
The gap (A) should be 0.5 mm (0.02 in.). Swing the upperstructure slightly to the left and lightly press the arm point to the left side of the bucket (the side without an adjuster).

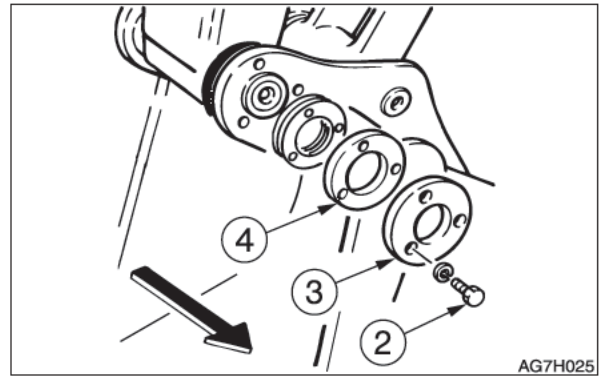

4. Remove the three bolts (2), the end plate (3) and flange (4).

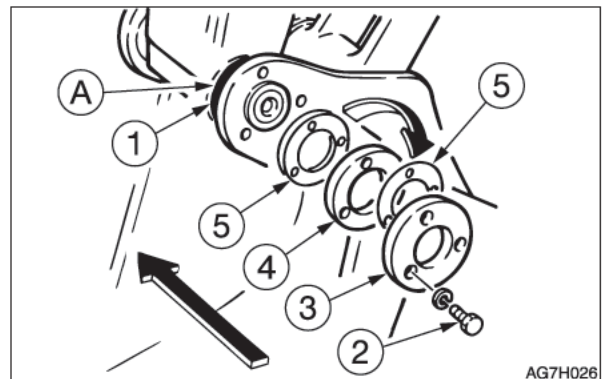

5. Pull out the adjustment shim(s) (5) corresponding to the gap (A) from between the flange (4) and the bucket body.
Adjustment shim thickness : 0.5 mm (0.02 in.)
Be careful that the gap is no less than 0.5 mm (0.02 in.) after adjustment.

Note:

Example (for a gap of 2 mm or 0.08 in.):
2 mm - 0.5 mm (standard value) = 1.5 mm (0.06 in.)
In the above example, three shims (5) should be removed.

6. Insert the adjustment shim(s) (5) removed in step 5 above between the end plate (3) and the flange (4), and then fasten it in place with the three bolts (2).
 - Tightening torque for bolts (2): 83 N·m (61.5 ft·lb.)
7. Return the O-ring (1) to the original position.



INSPECTING AND REPLENISHING THE WINDSHIELD WASHER FLUID

WARNING

Choose ethyl alcohol as washer solution. Do not use methyl alcohol as washer solution. It could damage the eyes.

Use a windshield washer fluid designed specifically for motor vehicles. Follow the instructions included with the washer fluid.

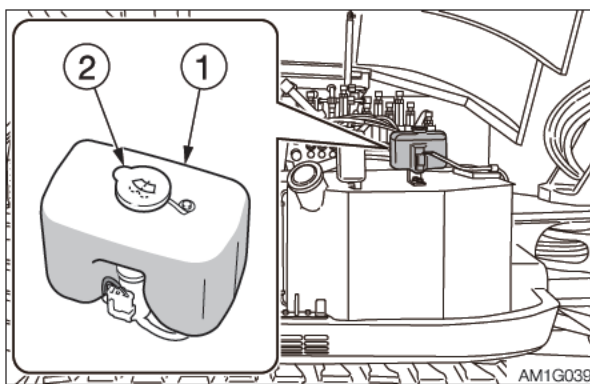

Inspection

1. Open the side cover.
2. Inspect the washer tank (1) and add washer fluid if the level is low.

Replenishing

1. Mix the washer fluid to the prescribed concentration.
2. Remove the cap (2) and add washer fluid. Keep the dust away while replenishing the washer fluid.
3. Install the cap (2).

DRAINING THE WATER FROM THE WATER SEPARATOR

WARNING

- Do not smoke or permit open flames while handling fuel or working on the fuel system.
- Stop the engine in a well-ventilated place and allow it to cool down before performing maintenance.
- Clean up spilled fuel immediately.

<TB285>

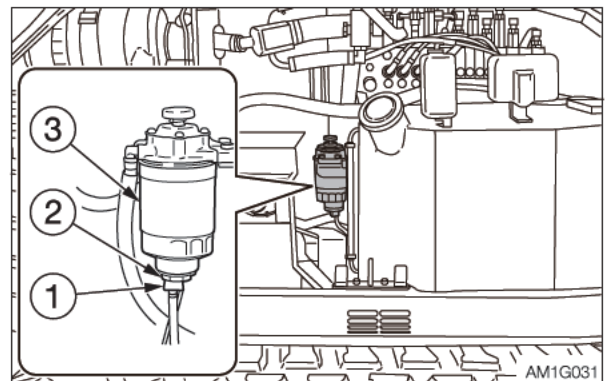

<TB290>

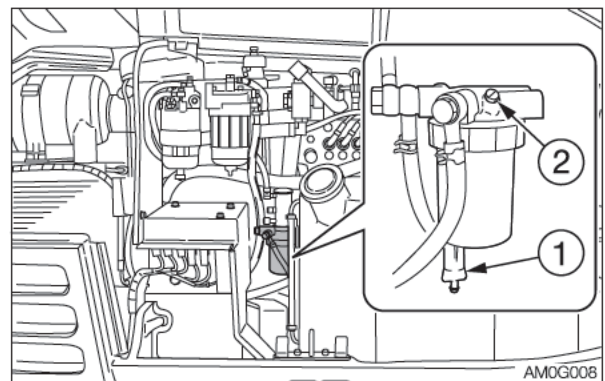

1. Open the side cover.
 2. Place a pan under the drain valve (1) to catch fuel.
 3. Open the drain valve (1) and drain the water.
If the water does not drain easily, loosen the plug (2). <TB290>
 4. Close the drain valve (1) and tighten the plug (2) <TB290>.
- Refer to "Bleeding air from the fuel system" on page 6-8.



LUBRICATING THE LEVERS AND PEDALS

⚠ WARNING

Set the machine to the parking posture, stop the engine, remove the starter key and store it. Failure to do so may result in the machine moving abruptly, leading to serious injury or death.

If the levers or pedals no longer move smoothly, grease them.

Operating levers

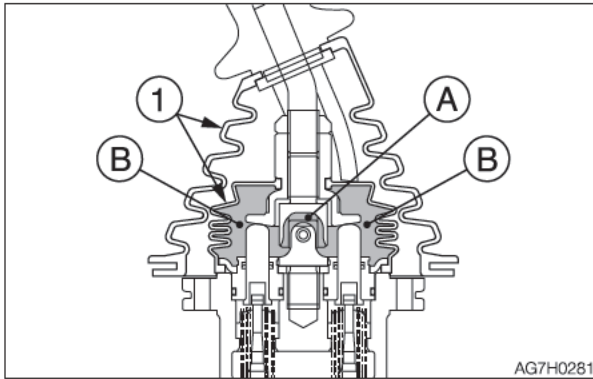

Travel levers

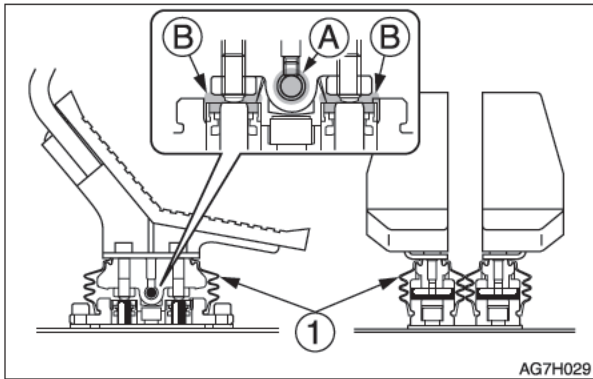

Boom swing pedal

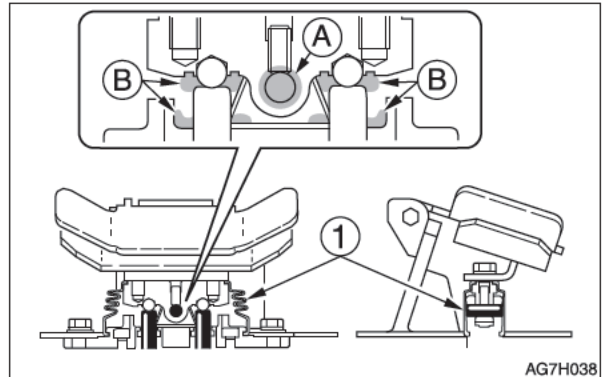

Dozer blade lever

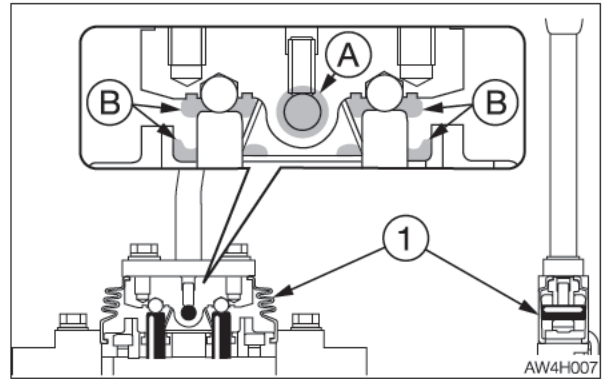

1. Remove the lower mount section of the boot (1) and turn it upward.
2. Wipe off the old grease.
3. Apply grease to points (A) and (B).
4. Set the boot (1) back as it was.



INSPECTING THE RUBBER CRAWLERS

Repair or replace the rubber crawlers if their condition becomes as described below. Consult your sales or service dealer for repair or replacement.

Rubber crawler

Replace the crawler if the entire crawler is stretched and cannot be adjusted.

(1) Lug

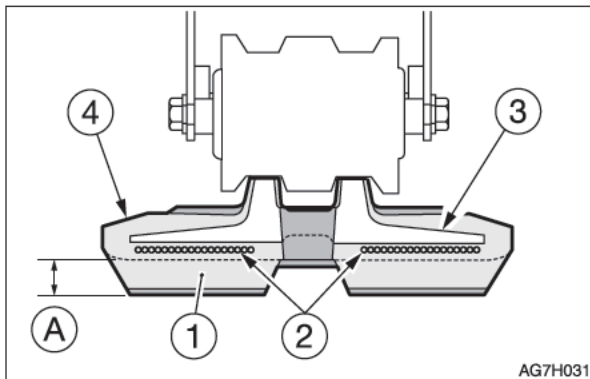

Replace if the height of (A) is 5 mm (0.2 in.) or below.

(2) Steel cord

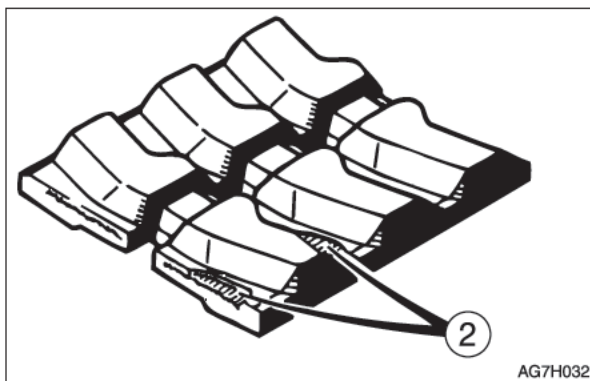

Replace if the steel cord is exposed for two links or more.
Replace if the half or more of the steel cords on one side are cut.

(3) Metal core

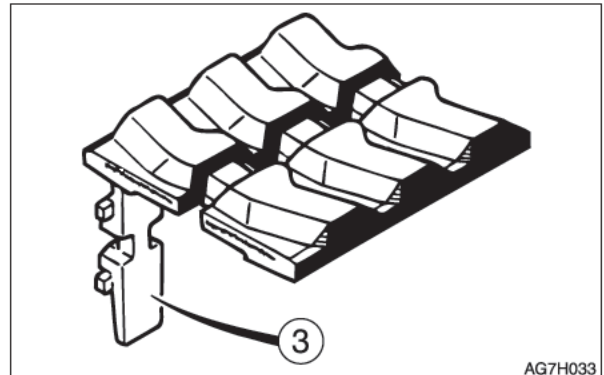

Replace if even one metal core is off.

(4) Rubber

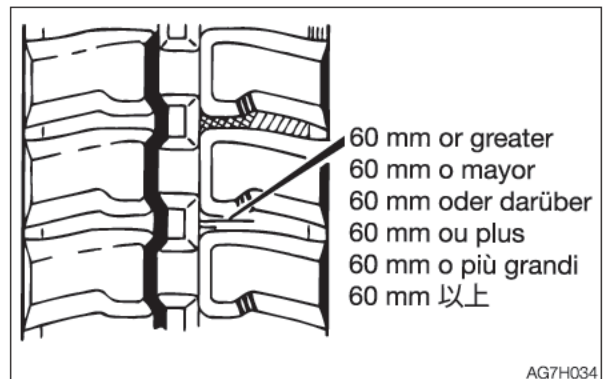

Repair if there are cracks of 60 mm (2.4 in.) or greater in length.
If the steel cord is visible, repair as soon as possible, regardless of the length of the crack.



REPLACING THE RUBBER CRAWLERS

WARNING

- If you must work beneath the raised machine or working equipment, always use wood blocks, jack-stands or other rigid and stable supports. Never get under the machine or working equipment if they are not sufficiently supported.
- If maintenance must be performed with the engine running, always work as a two person team communicating each other.
 - One person must sit in the operator's seat so that he/she can immediately stop the engine when necessary. He/she must take care not to touch the lever or pedal unless necessary.
 - The one who performs maintenance must make sure to keep his/her body or clothing away from the moving part of the machine.

IMPORTANT: When replacing the crawler belts, replace the right and left belts at the same time.

IMPORTANT: When the travel speed button is set to the 2nd speed side while the engine is running, the tensioning cylinder rods extend and the crawler belt tension is increased. Keep the engine at the 1st speed when replacing. Do not set to the 2nd unless for increasing tension.

Note: This machine uses a hydraulic cylinder to adjust the tension of the crawler belts. It is not necessary to regularly perform adjustments of the crawler belt tension.

Removal

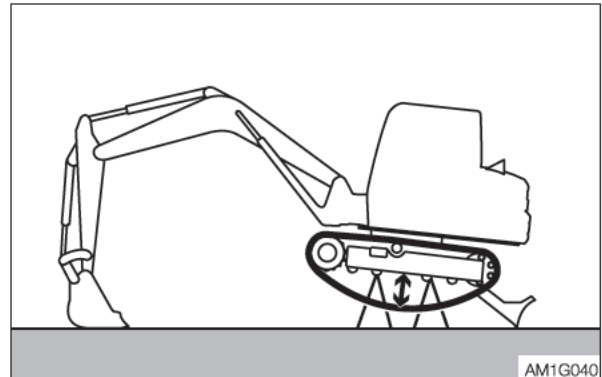

1. Start the engine and raise the machine body with the hoe attachment and the dozer blade.
2. Stop the engine.

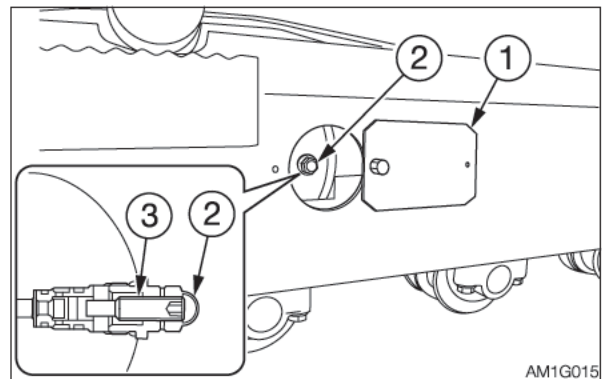

3. Remove the valve cover (1) at the center of one of the crawler frames.
4. Turn the plug (2) counterclockwise and remove it.
5. Turn the stem (3) counterclockwise with a hex wrench to completely loosen the tension of the crawler.
6. Once the crawler belt is completely loose, tighten the stem (3) until it is firm.
 - Tightening torque: 18.6 to 21.6 N·m (13.7 to 15.9 ft-lb.)
7. Tighten the plug (2).
 - Tightening torque: 18.6 to 21.6 N·m (13.7 to 15.9 ft-lb.)
8. Do the same for the other side.

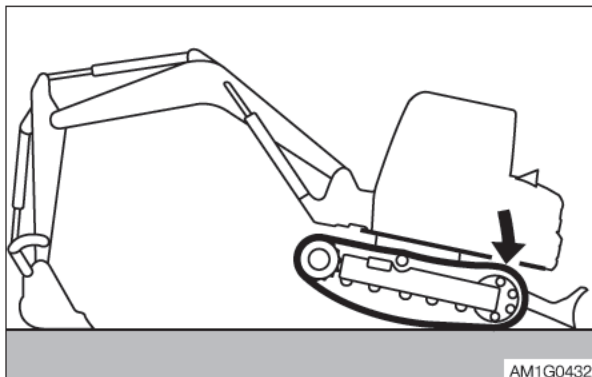

9. Slowly lower the dozer blade side of the machine body. (Do not start the engine.)
10. Lower the machine body until the crawlers contact the ground with the maximum slack.
11. When the crawlers are disengaged from the idlers, slide the crawlers to the outside and remove them.
12. Remove the crawlers from the sprockets, and then remove the crawlers from the crawler frames.

Installation

1. Engage the crawlers around the left and right sprockets.
2. Set the left and right crawlers on the idlers.
3. Start the engine.
4. Press the travel speed button once to set it to the 2nd speed side. The left and right crawler belts are tightened simultaneously.

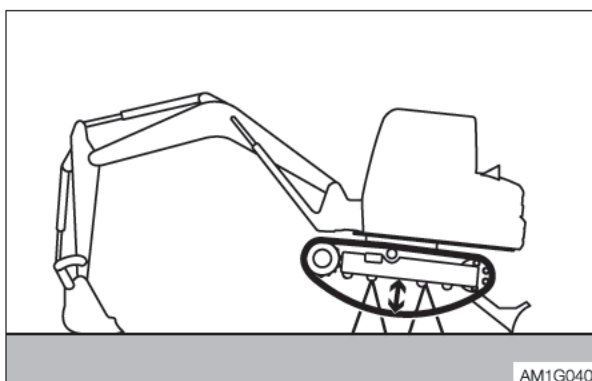

5. Check that the crawler belts are properly tightened.

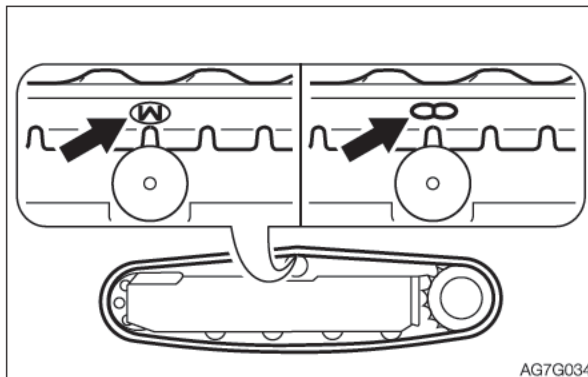

6. For rubber crawlers, move the machine so that the “M” or “∞” mark at the joint is at the top center of the crawler frame.

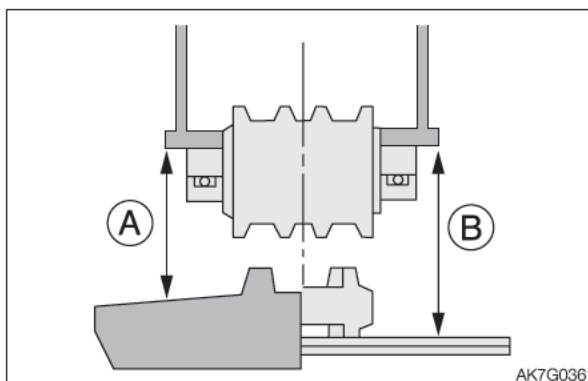

7. Inspect the gap (A or B) between the bottom surface of the frame at the center of the crawler frame and the top surface of the crawler.
The gap (A or B) must be within the following range:

- (A).....Rubber crawler
160 to 180 mm (6.3 to 7.1 in.)
- (B)Steel crawler
260 to 280 mm (10.2 to 11.0 in.)
- (B)Rubber pads
245 to 265 mm (9.6 to 10.5 in.)

Note: When the self-adjusting shoe tension system is properly working, the shoe should have the gap (A or B) as described above, at the time of installation.

When the machine is lowered and driven in 2nd speed, the crawler belts will be stretched to the correct tension. The values of shoe tension (gap values) after the 2nd speed travel are different from those described above.



MAINTENANCE DURING EXTENDED STORAGE PERIOD

Storage procedures

If the machine is to be stored for 30 days or more, store it indoors. If it must be stored outdoors, park the machine on a surface laid with lumber on a flat ground, and place a waterproof cover over it so that it stays dry.

1. Clean the machine.
2. Inspect for oil leakage, water leakage, cracks and loose nuts and bolts.
3. Add fuel and replace the hydraulic oil and oil.
4. To prevent rusting and freezing, replace the engine coolant with long-life coolant (LLC).
Refer to "Cleaning the engine cooling system" on page 5-48.
5. Use the grease gun to lubricate the grease fittings.
6. Fully retract the bucket and arm cylinders and lower the bucket and dozer blade to the ground.
7. Apply rust-inhibiting oil to the hydraulic cylinder rods.
8. Disconnect the negative cable from the battery and cover the battery to prevent freezing.

During storage

WARNING

- Do not operate the machine in an enclosed area without adequate ventilation.
- If natural ventilation is not possible, install ventilators, fans, exhaust extension pipes or other venting devices.

1. To prevent rusting, operate the machine once a month so that the oil can be circulated throughout the system.
2. Inspect the battery and recharge it as necessary.
Ask your sales or service dealer for recharging.

Starting the machine after storage

IMPORTANT: If the above "Storage procedures" have not been followed during the extended storage periods, consult your sales or service dealer before starting the machine again.

1. Wipe off the rust-inhibiting oil that was applied on the piston rods of the hydraulic oil cylinders.
2. Add oil or grease as necessary.

Returning the engine to service

1. Perform the daily checks.
2. The engine should be pre-oiled before startup.
 - a. Crank the engine, leaving the fuel system shut off so the engine will not start, for 15 seconds.
 - b. Then pause for 30 seconds.
 - c. Repeat the procedure until you have cranked the engine for a total of one minute. This will circulate the oil in the engine's lubrication system.
3. Prime the fuel system.
4. Start the engine. Allow the engine to idle for approximately 15 minutes while you check for:
 - Proper oil pressure
 - Fuel, engine oil or coolant leaks
 - Proper operation of the indicators and/or gauges
5. Avoid prolonged operation at minimum or maximum engine speeds and loads for the remainder of the first hour of operation.

TROUBLESHOOTING



SYMPTOMS THAT ARE NOT MALFUNCTIONS

The symptoms listed below are not malfunctions.

- It becomes less easy to operate the machine when an attachment weighing more than a standard arm or bucket is installed.

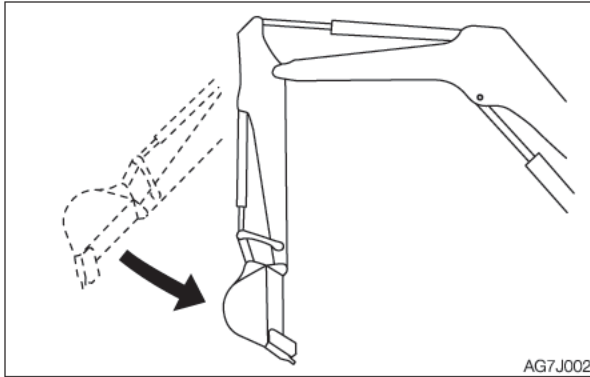

- The arm retracting speed momentarily slows down when it reaches an almost vertical position while the engine is running at low speed.

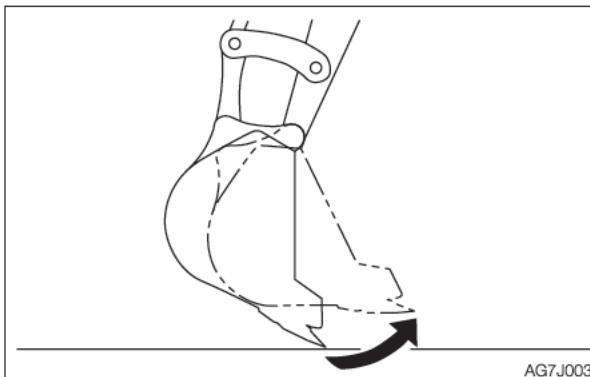

- The bucket teeth moving speed momentarily slows down when it reaches an almost horizontal position while the engine is running at low speed.
- The slew motor produces noise at the beginning and end of the slewing.
- The travel motor produces noise when stopped suddenly from its high speed traveling.
- The control valve produces noise if excessive force is applied to the working equipment or when it moved to the stroke end.



IF THE ENGINE OVERHEATS

WARNING

- Do not open the engine hood when steam is coming from it. The steam or hot water may spurt out and cause burns.
- Do not try to remove the radiator cap or the drain plug when the cooling water is hot. Stop the engine, wait until the engine and the radiator cool, and then slowly loosen the radiator cap to release the internal pressure.
- Before performing maintenance, stop the engine and allow the machine to cool down.

The symptoms listed below indicate overheating.

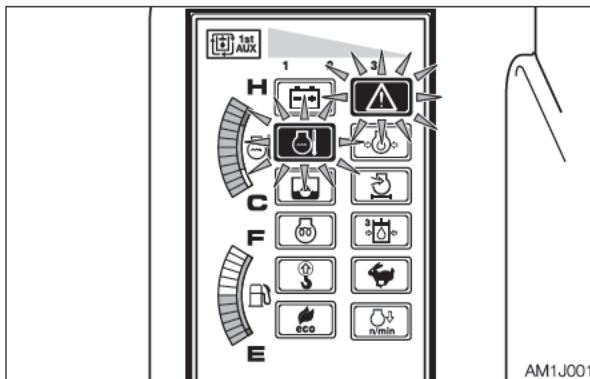

- An alarm is sounded and the engine emergency lamp and the coolant temperature warning lamp start flashing.
- The water temperature gauge LED is in the red zone.
- The engine slows down and the engine power decreases.
- Steam comes from the engine room.

Remedy procedure

1. Park the machine in a safe place.
2. Check if steam is coming out of the closed engine hood.
3. If there is steam, stop the engine immediately and contact your sales or service dealer for repair. If steam is not coming out run the engine at low idle and let the water temperature cool down.
4. When the water temperature gauge LED drops in the green zone, stop the engine.
5. Perform the inspections and the remedies listed below once the engine cools down.
 - Fan belt slack..... Adjust
Refer to page 5-24.
 - Coolant level Add
Refer to page 5-16.
 - Water leakage Repair
 - Radiator fins..... Clean
Refer to page 5-39.
 - Sediment in cooling system
..... Clean
Refer to page 5-48.

If the problem persists after the above remedies, contact your sales or service dealer for repair.



IF THE BATTERY GOES DEAD

The symptoms below indicate that the battery is dead.

- The starter motor does not turn or fails to start the engine.
- The horn is too weak.

Remedy procedure

Start the engine using the booster battery on the other vehicle (booster vehicle) and the jumper cables.

WARNING

- When starting the engine using the jumper cables, be sure to connect the cables by following the proper steps. Improper use of jumper cables can result in battery explosion or unexpected machine motion.
 - Do not allow the booster vehicle and the machine with a dead battery (dead machine) to touch each other.
 - Do not allow the positive (+) and the negative (-) clips of the jumper cables to touch each other.
 - When connecting, attach the jumper cable to the positive (+) terminals first. When disconnecting, remove the cable from the negative (-) terminal (ground) first.
 - Connect the last clip of the jumper cable to a point as far away from the battery as possible.
- Always wear the protective goggle when jump starting the engine by using the jumper cables.

IMPORTANT: Use the jumper cables and clips of a size suited to the capacity of battery. Do not use damaged or corroded jumper cables and clips.

IMPORTANT: Be sure that the battery of the booster vehicle has the same capacity as the battery of the dead machine.

IMPORTANT: Be sure to connect the clips securely.

Connecting the jumper cables

IMPORTANT: Set the starter keys of the booster vehicle and the dead machine to the OFF position.

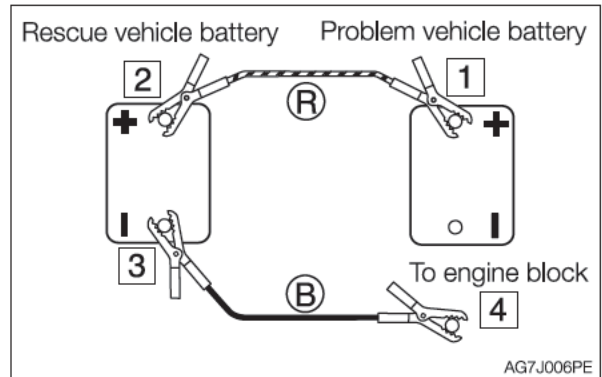

1. Connect the clip of jumper cable (R) to the positive (+) battery terminal of the dead machine.
2. Connect the other clip of jumper cable (R) to the positive (+) battery terminal of the booster vehicle.
3. Connect the clip of jumper cable (B) to the negative (-) battery terminal of the booster vehicle.
4. Connect the other clip of jumper cable (B) to the engine block of the dead machine. Connect the clip to a place as far from the battery as possible.

Starting the engine

1. Check that the clips are securely connected to the terminals.
2. Start the engine of the booster vehicle and run it at high speed.
3. Start the engine of the dead machine.



TROUBLESHOOTING IF THE BATTERY GOES DEAD

Disconnecting the jumper cables

Once the dead machine is successfully running, remove the jumper cables by following the same steps as for connection in the reverse order.

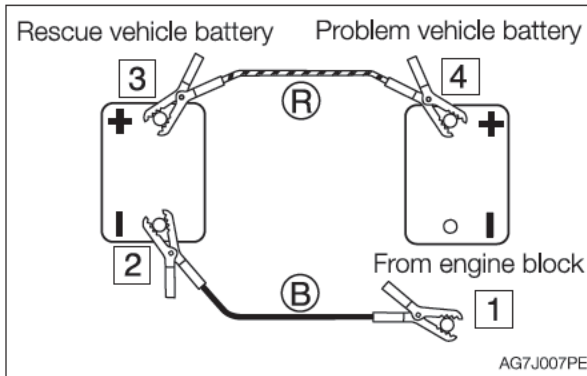

1. Disconnect the clip of jumper cable (B) from the engine block of the dead machine.
2. Disconnect the other clip of jumper cable (B) from the negative (-) battery terminal of the booster vehicle.
3. Disconnect the clip of jumper cable (R) from the positive (+) battery terminal of the booster vehicle.
4. Disconnect the clip of jumper cable (R) from the positive (+) battery terminal of the dead machine.

Recharging

Ask your sales or service dealer for recharging the dead battery.



IF A FUSE BLOWS

If a light does not come on or the electrical system does not work, a fuse may be blown. Inspect the fuses.

INSPECTING AND REPLACING THE FUSE

⚠ WARNING

If the fuse blows again soon after replacement, then the electric system is likely faulty. It may pose a fire hazard if not properly repaired. Contact your sales or service dealer for advice.

1. Turn the starter key to the OFF position to stop the engine.

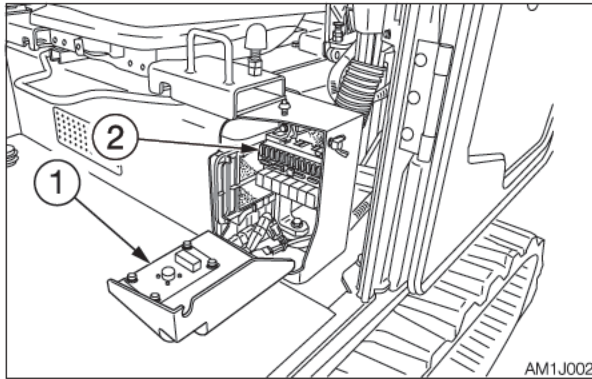

2. Open the fuse box cover (1).
3. Check for any blown fuses (2).

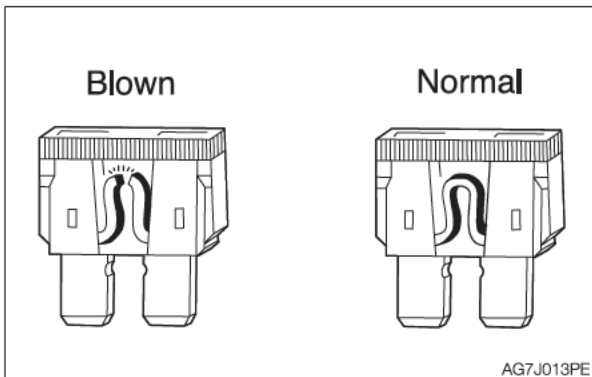

4. If a fuse is blown, replace it with a spare fuse of the same capacity.

Fuse layout and circuits protected

Capacity	Protected circuit	Capacity	Protected circuit
15A	ECM (ACC)	25A	Light
10A	Starter switch (C)	10A	Wiper
5A	Controller (B)	20A	Solenoid
10A	Horn, interior light	10A	Controller (ACC)
		20A	Cigarette lighter, radio, beacon lamp
		10A	Alarm
		25A	Air conditioner blower
		10A	Air conditioner compressor
		5A	Air conditioner controller
		25A	Option (1)
		15A	Option (2)
		25A	Option (3)



INSPECTING THE FUSIBLE LINK

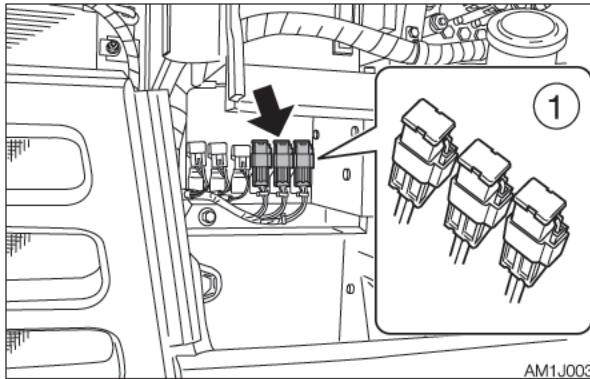

If the machine is not turned on after turning the starter switch to the ON position, the cartridge type fusible link (1) is likely blown. Open the side cover and inspect it. If the fusible link is blown, contact your sales or service dealer.

Note: Fusible links are large type fuses used in high current applications. Like a regular fuse, they act as fuses by protecting the electric components and wirings from damage caused by excessive current draw.



RESTARTING AFTER ADDING FUEL

BLEEDING AIR FROM THE FUEL SYSTEM

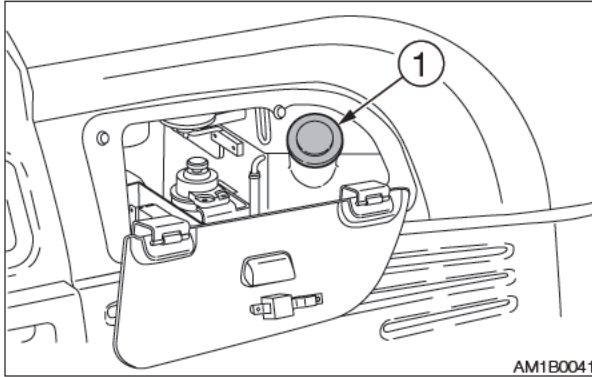

1. Add fuel.

<TB285>

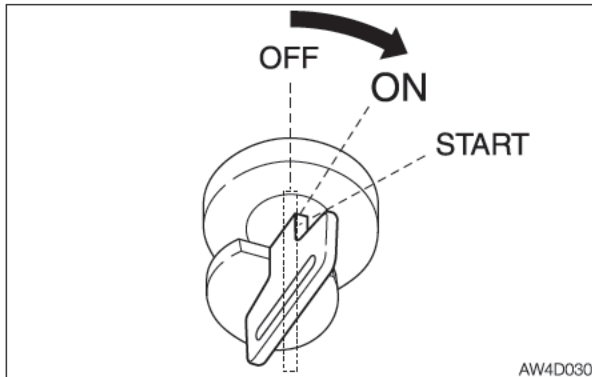

2. Turn the starter key to the ON position and hold it for about 10 to 15 seconds.

The automatic air bleeder bleeds air from the fuel system.

<TB290>

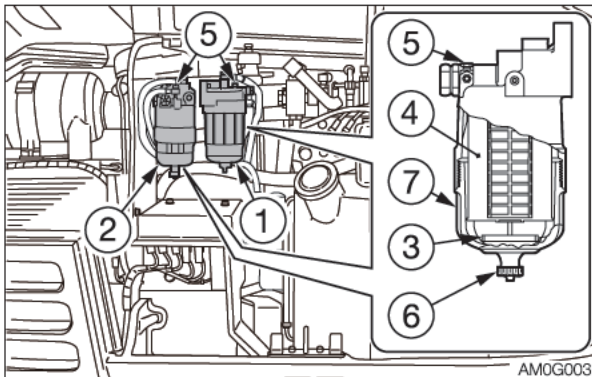

2. Loosen the vent plug (5) of the main fuel filter (2).

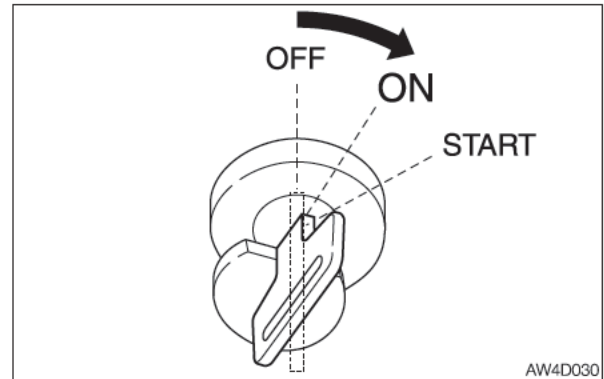

3. Turn the starter key to the ON position and wait for the air to be bled from the vent plug (5).

4. Retighten the vent plug (5) when air bleeding is finished and fuel starts leaking out from around the vent plug (5).

5. Turn and hold the starter key to the ON position for three minutes before turning it back to the OFF position.



Note: Air in the fuel system causes the engine to fail to start or to have other problems. Always bleed air when the fuel tank is emptied or when there is air in the fuel system.

MEMO





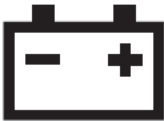

IF A WARNING LAMP FLASHES

If an alarm is sounded or a warning lamp starts flashing during operation, park the machine in a safe place and perform the remedy procedures described below.

Warning lamp	Lamp name	Causes and remedies
 AW4J007	Vehicle and engine emergency lamp	<p>There is a problem in the machine. Refer to the respective warning lamp below. Get the vehicle or engine error code number from the multi-data display and consult your sales or service dealer referring to the number on the "Vehicle error code list" or "Engine error code list". Refer to "Vehicle error code list" on page 6-12. Refer to "Engine error code list" on page 6-14.</p>
 AG7J019	Battery charge warning lamp	<p>There is a problem with the fan belt or charger. Check the fan belt for slack or breakage and adjust as necessary. If the lamp continues flashing after maintenance, there is likely a problem with the charger. Consult your sales or service dealer for help. Refer to "Inspecting and adjusting the fan belt" on page 5-24.</p>
 AG7J017	Engine oil pressure warning lamp	<p>There is a problem in the engine lubrication system. Check the engine oil level. If the lamp is flashing when the level is normal or even after replenishment of oil or coolant, consult your sales or service dealer. Refer to "Inspecting and replenishing the engine oil" on page 5-17.</p>
 AG7J018	Coolant temperature warning lamp	<p>The coolant temperature is too high and the engine is overheating. Refer to "If the engine overheats" on page 6-3.</p>



TROUBLESHOOTING IF A WARNING LAMP FLASHES

Warning lamp	Lamp name	Causes and remedies
 AG7J020	Air cleaner warning lamp	The air cleaner is clogged. Clean it. Refer to "Cleaning the air cleaner" on page 5-38.
 AW4J009	Water separator warning lamp	Water is in the water separator. Drain water. Refer to "Draining the water from the water separator" on page 5-63.
 AM1J004	Third auxiliary hydraulic warning lamp	Pressure in the third auxiliary hydraulic line is too low Consult your sales or service dealer for help.
 AM1J005	Overload warning lamp	This lamp starts flashing if the overload warning device is activated. If it occurs, reduce the load to be lifted. Refer to "Overload warning device" on page 2-53.



VEHICLE ERROR CODE LIST

When the multi-data display is set to the data mode, the number that is corresponding to the error, if applicable, appears in the error code field. Up to four types of error codes are displayed (the leftmost code is the most recent error). If this occurs, consult your sales or service dealer for help.

Error code	Error details
102	CAN communication error (BusOff)
902	CAN communication error (ECM)
1002	CAN communication error (cluster gauge)
1703	Power supply voltage error (too high)
1704	Power supply voltage error (too low)
1720	Proportional amplifier system abnormality
3300	Alternator charge faulty
3401	Engine oil pressure error
3500	Overheat
3600	Air cleaner clogged
3700	Water separator
3800	Hydraulic oil filter clogged
5303	Accelerator sensor error (too high)
5304	Accelerator sensor error (too low)
5603	Lift alarm sensor error (cable break)
5604	Lift alarm sensor error (short circuit)



TROUBLESHOOTING VEHICLE ERROR CODE LIST

Error code	Error details
6513	AUX1 slide switch neutral error
6613	AUX2 slide switch neutral error
6503	AUX1 slide switch voltage value error (too high)
6504	AUX1 slide switch voltage value error (too low)
6603	AUX2 slide switch voltage value error (too high)
6604	AUX2 slide switch voltage value error (too low)
6731	AUX3 input error
6813	AUX1 button A error
6913	AUX1 button B error
7106	Pump PWM output electric current error (short circuit)
7105	Pump PWM output electric current error (open)
7206	AUX1 (L) PWM output electric current error (short circuit)
7205	AUX1 (L) PWM output electric current error (open)
7306	AUX1 (R) PWM output electric current error (short circuit)
7305	AUX1 (R) PWM output electric current error (open)
7406	AUX2 (L) PWM output electric current error (short circuit)
7405	AUX2 (L) PWM output electric current error (open)
7506	AUX2 (R) PWM output electric current error (short circuit)
7505	AUX2 (R) PWM output electric current error (open)

PWM = Pulse width modulation



ENGINE ERROR CODE LIST

When the engine error code is displayed on the multi-data display, the number that is corresponding to the error, if applicable, appears in the error code field. Up to three types of error codes are displayed, with the latest code at the top. If this occurs, consult your sales or service dealer for help.

<TB285>

Error code		Error details
SPN	FMI	
1210	4	Engine Fuel Rack Position Sensor: Shorted to low source
	3	Engine Fuel Rack Position Sensor: Shorted to high source
108	4	Barometric Pressure Sensor: Shorted to low source
	3	Barometric Pressure Sensor: Shorted to high source
	2	Barometric Pressure Sensor: Intermittent fault
1136	4	E-ECU Internal Temperature Sensor: Shorted to low source
	3	E-ECU Internal Temperature Sensor: Shorted to high source
	2	E-ECU Internal Temperature Sensor: Intermittent fault
	0	E-ECU Internal Temperature: Too high
110	4	Engine Coolant Temperature Sensor: Shorted to low source
	3	Engine Coolant Temperature Sensor: Shorted to high source
	2	Engine Coolant Temperature Sensor: Intermittent fault
	0	Engine Coolant Temperature: Too high
1079	4	Sensor 5V: Shorted to low source
	3	Sensor 5V: Shorted to high source
	2	Sensor 5V: Intermittent fault
158	1	System Voltage: Too low
	0	System Voltage: Too high
1078	4	Engine Fuel Injection Pump Speed Sensor: Shorted to low source
522402	4	Auxiliary Speed Sensor: Shorted to low source
522241	4	Engine Fuel Rack Actuator Relay: Circuit fault A
	3	Engine Fuel Rack Actuator Relay: Circuit fault B
	7	(Reserved)
	2	Engine Fuel Rack Actuator Relay: Intermittent fault
522243	4	Air Heater Relay: Circuit fault A
	3	Air Heater Relay: Circuit fault B
	2	Air Heater Relay: Intermittent fault
522242	4	Cold Start Device: Circuit fault A
	3	Cold Start Device: Circuit fault B
	2	Cold Start Device: Intermittent fault
522251	4	EGR Stepping Motor "A": Circuit fault A
	3	EGR Stepping Motor "A": Circuit fault B
522252	4	EGR Stepping Motor "B": Circuit fault A
	3	EGR Stepping Motor "B": Circuit fault B
522253	4	EGR Stepping Motor "C": Circuit fault A
	3	EGR Stepping Motor "C": Circuit fault B
522254	4	EGR Stepping Motor "D": Circuit fault A
	3	EGR Stepping Motor "D": Circuit fault B



TROUBLESHOOTING ENGINE ERROR CODE LIST

<TB285>

Error code		Error details
SPN	FMI	
100	4	Oil Pressure Switch: Shorted to low source
	1	Oil Pressure: Too low
167	4	Battery Charge Switch: Shorted to low source
	1	Charge warning
522314	0	Engine Coolant Temperature: Abnormal temperature
522323	0	Air Cleaner: Mechanical malfunction
522329	0	Oily Water Separator: Mechanical malfunction
190	0	Engine speed: Overspeed condition
638	4	Engine Fuel Rack Actuator: Shorted to low source
	3	Engine Fuel Rack Actuator: Shorted to high source
	7	Engine Fuel Rack Actuator: Mechanical malfunction
	2	Engine: Malfunction
639	12	High-speed CAN Communication: Communication fault
630	2	E-ECU internal fault: EEPROM checksum error (Data Set 2)
	12	E-ECU internal fault: EEPROM read/write fault
628	12	E-ECU internal fault: Flash ROM checksum error (Main software)
	2	E-ECU internal fault: Flash ROM checksum error (Data Set 1)
	2	E-ECU internal fault: Flash ROM checksum error (Data Set 2)
1485	4	E-ECU Main Relay: Shorted to low source
522727	12	E-ECU internal fault: Sub-CPU error A
	12	E-ECU internal fault: Sub-CPU error B
	12	E-ECU internal fault: Sub-CPU error C
522728	12	E-ECU internal fault: Engine Map Data Version Error
522730	12	Immobilizer: CAN communication fault
	8	Immobilizer: Pulse communication fault
1202	2	Immobilizer: System fault



TROUBLESHOOTING ENGINE ERROR CODE LIST

<TB290>

Error code		Error details
SPN	FMI	
110	3, 4	Coolant temp sensor failure
	0	Engine overheat
157	3, 4	C. Rail press. sensor failure
	2	C. Rail press. too hi
	0	C. Rail press. hi 1
	0	C. Rail press. hi 2
172	3, 4	Intake air temp sensor failure
174	3, 4	Fuel temp sensor failure
190	0	Engine overspeed
628	2	ROM error
633	7	Pressure limiter open
636	2	Cam sensor failure
	7	Cam-Crank phase error
639	2	CAN BusOff error
	3	CAN timeout error
651	3	Injector #1 failure
652	3	Injector #2 failure
653	3	Injector #3 failure
654	3	Injector #4 failure
655	3	Injector #5 failure (for 6cyl. ENG)
656	3	Injector #6 failure (for 6cyl. ENG)
675	3	Glow lamp failure
676	3	Glow relay failure
677	3	Starter cut relay failure



TROUBLESHOOTING ENGINE ERROR CODE LIST

<TB290>

Error code		Error details
SPN	FMI	
723	2	Crank sensor failure
968	2	Idle up/down switch failure
987	3	Check engine lamp failure
1077	2	CPU error
1079	2	5V power system 1 failure
1080	2	5V power system 2 failure
1239	1	Pump press low (fuel leak)
1347	0	SCV failure
1381	3, 4	Clogged fuel filter failure
1485	2	Main relay failure
10001	3	EGR sensor failure
10002	2	EGR valve failure
10003	2	Injector com 1 failure
10004	2	Injector com 2 failure
10005	1	Charge circuit 1 failure
10006	1	Charge circuit 2 failure
10007	2	Sub CPU error
10008	2	A/D converter failure
10009	2	5V power system 3 failure
10010	2	5V power system 4 failure
10011	2	5V power system 5 failure
10012	2	12V power system failure
10013	2	EEPROM error



OTHER SYMPTOMS

For symptoms not included in the table below or if the problem persists after the proper remedies have been taken, consult your sales or service dealer.

Symptoms	Major causes	Remedies
Left and right operating levers do not move smoothly	<ul style="list-style-type: none">• Insufficient grease on the left and right operating levers	<ul style="list-style-type: none">• Grease the levers. Refer to page 5-64.
Travel levers, blade lever and pedals do not move smoothly	<ul style="list-style-type: none">• Insufficient grease on travel levers, blade lever and pedals	<ul style="list-style-type: none">• Grease the levers and pedals. Refer to page 5-64.
Operation of hoe attachment, dozer blade, auxiliary hydraulics, slewing or traveling is not possible.	<ul style="list-style-type: none">• Safety lock lever is raised (locked)• Fuse is blown	<ul style="list-style-type: none">• Lower (release) the safety lock lever. Refer to page 2-31.• Replace the fuse. Refer to page 6-6.
Digging force is insufficient	<ul style="list-style-type: none">• Hydraulic oil level too low• Hydraulic oil is not warm enough• Air cleaner is clogged• Hydraulic oil is not of suitable type	<ul style="list-style-type: none">• Add to the specified level. Refer to page 5-20.• Perform the warm-up. Refer to page 3-8.• Clean the air cleaner. Refer to page 5-38.• Replace the hydraulic oil. Refer to page 5-54.
Traveling is not possible or not smooth	<ul style="list-style-type: none">• Stones or foreign objects are stuck	<ul style="list-style-type: none">• Remove the foreign object.
Machine veers to the right/left	<ul style="list-style-type: none">• Stones or foreign objects are stuck• Crawler belt tension is faulty.	<ul style="list-style-type: none">• Remove the foreign object.• Check and adjust (ask your sales or service dealer). Refer to page 5-28.
Travel speed cannot be changed	<ul style="list-style-type: none">• Fuse is blown	<ul style="list-style-type: none">• Replace the fuse. Refer to page 6-6.



TROUBLESHOOTING OTHER SYMPTOMS

Symptoms	Major causes	Remedies
Slewing is not possible or not smooth	<ul style="list-style-type: none">• Insufficient grease on slew bearing	<ul style="list-style-type: none">• Grease the bearing. Refer to page 5-30.
Hydraulic oil temperature is too high	<ul style="list-style-type: none">• Hydraulic oil level too low	<ul style="list-style-type: none">• Add up to the specified level. Refer to page 5-20.
Starter motor turns but engine does not start	<ul style="list-style-type: none">• Insufficient fuel• Air in fuel system• Water in fuel system	<ul style="list-style-type: none">• Add fuel. Refer to page 5-19.• Bleed air. Refer to page 6-8.• Drain water. Refer to page 5-31.
Crawlers come off	<ul style="list-style-type: none">• Crawlers too loose• Tensioning cylinder valve is loose.	<ul style="list-style-type: none">• Check and adjust (ask your sales or service dealer). Refer to page 5-28.• Increase the tension. Refer to page 5-29.
Engine exhaust is white or bluish	<ul style="list-style-type: none">• Excessive engine oil• Poor fuel	<ul style="list-style-type: none">• Adjust to the specified level. Refer to page 5-17.• Replace the fuel.
Engine exhaust is occasionally black	<ul style="list-style-type: none">• Air cleaner is clogged	<ul style="list-style-type: none">• Clean the air cleaner. Refer to page 5-38.
Irregular noise is produced from the engine (combustion or mechanical noise)	<ul style="list-style-type: none">• Low quality fuel is being used• Engine is overheating• Damage inside the muffler	<ul style="list-style-type: none">• Replace the fuel.• Refer to “If the engine overheats” on page 6-3.• Replace the muffler. For replacement, ask your sales or service dealer.



LOWERING THE BOOM TO THE GROUND

If the hoe attachment must be lowered to the ground while the engine is stopped, use the following procedure.

Procedure 1 (when engine can be started)

Perform this operation within 10 minutes after the engine stopping.

1. Sit at the operator's seat.
2. Turn the starter switch to the ON position.
3. Lower the safety lock lever to the unlock position
4. Slowly push the operating lever forward to lower the boom.

Procedure 2 (when engine cannot be started)

This operation is dangerous and requires experience. Ask your sales or service dealer for it.

WARNING

- Stop the engine and allow the machine to cool down before performing maintenance.
 - The engine and the hydraulic system and many other parts of the machine are hot immediately after the engine is stopped. Touching these parts will cause burns.
 - The hydraulic oil is also hot and under high pressure immediately after the engine is stopped. Be careful when loosening the caps or plugs. Working on the machine under these conditions could result in burns or injuries due to the hot oil spurting out.
- Keep away from the working area when the hoe attachment is lowered. You may be hit by dirt falling out of the bucket or the hoe attachment as it drops.
- Stand in a position away from danger of lowering boom and loosen the hose nut. Otherwise, you could be hit by the boom.

- Do not loosen or remove the hoses not located in the specified places. Oil may spurt out if wrongly handled.

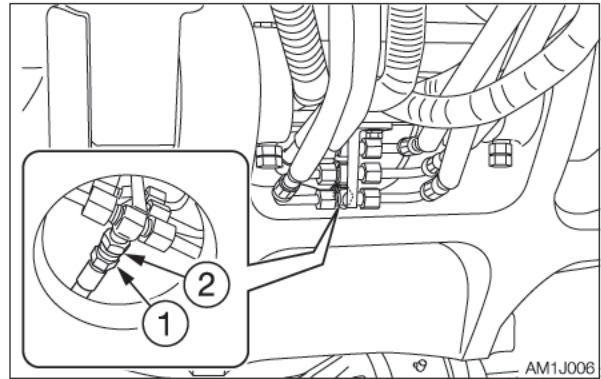

2-Piece boom

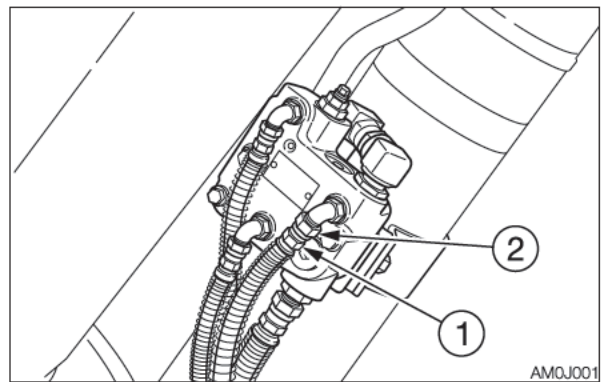

1. Place a pan under the hose to catch the waste oil.
2. Hold the hose fitting (1) with a wrench and loosen the hose nut (2) with another wrench.
3. The oil in the boom cylinder is drained and the hoe attachment is lowered.
4. After the hoe attachment is lowered to the ground, check the safety and stability of the machine.
5. Hold the hose fitting (1) with a wrench and tighten the hose nut (2) with another wrench.
 - Tightening torque: 24.5 to 29.4 N·m (18.1 to 21.7 ft·lb.)



TOWING

WARNING

When towing, serious injury or death could result, if performed incorrectly or the wire rope being used is inappropriate or not properly inspected.

- It becomes dangerous if the wire rope breaks or becomes disengaged. Use a wire rope appropriate for the required tractive force.
- Do not use a wire rope that is kinked, twisted or otherwise damaged.
- Do not apply heavy loads abruptly to the wire rope.
- Wear safety gloves when handling the wire rope.
- Make sure there is an operator on the machine being towed as well as on the machine that is towing.
- Never tow on slopes.
- Do not let anyone come near to the wire rope while towing.

IMPORTANT: Do not tow a machine if its engine does not start or if the machine does not run. Doing so could damage the machine being towed.

IMPORTANT: Be sure to follow the steps below closely when using the towing hole to tow. Failure to heed even one of the steps may cause damage to the towing hole or other parts of the frame.

Towing the machine

Use the procedure described below to tow heavy objects or the machine itself if it should get stuck in the mud and not be able to get out on its own.

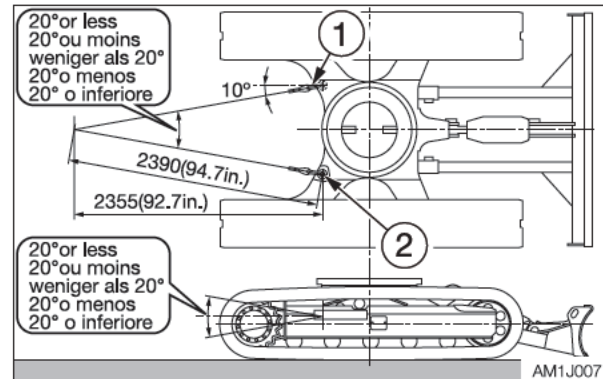

- Maximum tractive force: 125.2 kN (28146 lbf)

1. Attach the wire rope to the shackle (1).
2. Fasten the shackle (1) to the towing holes (2).
3. Make sure that the wire rope is at a cone angle of 20° or less to the travel frame.
4. Move the machine to tension the wire rope.
5. Operate the machine slowly and tow.

SPECIFICATIONS





BASIC SPECIFICATIONS

<TB285>

Type		Mono boom	2-Piece boom	
MASS				
Operating mass	kg (lb)	Rubber crawlers	8465 (18660)	8670 (19120)
		Steel crawlers	8700 (19185)	8905 (19635)
PERFORMANCE				
Bucker capacity (Standard bucket)	m ³ (cu. ft.)	Heaped	0.245 (8.65)	
		Struck	0.185 (6.53)	
Slew speed	min ⁻¹ (rpm)	10.3 (10.3)		
Travel speed	km/h (mph)	Rubber crawlers	1st	2.6 (1.62)
			2nd	5.0 (3.11)
		Steel crawlers	1st	2.5 (1.55)
			2nd	4.8 (2.98)
Gradeability	(degrees)	35		
Ground pressure	kPa (psi)	Rubber crawlers	37.9 (5.5)	38.8 (5.63)
		Steel crawlers	39.4 (5.72)	40.3 (5.85)
Noise level	dB (A)	Sound power level	L _{WA} 99	
		Sound pressure level	L _{pA} 74	
ENGINE				
Manufacturer and model		Yanmar 4TNV98T-ZXWTB2		
Rated output	kW/min ⁻¹ (hp/rpm)		49.6/2000 (66.5/2000)	
Displacement	ml (cu.in.)		3318 (202.5)	
Starter	V-kW		12-3.0	
Alternator	V-kW		12-0.96	
Battery	V-A·h		12-72	



SPECIFICATIONS
BASIC SPECIFICATIONS

<TB290>

Type		Mono boom	2-Piece boom	
MASS				
Operating mass	kg (lb)	Rubber crawlers	8515 (18770)	8720 (19230)
		Steel crawlers	8750 (19295)	8955 (19745)
PERFORMANCE				
Bucker capacity (Standard bucket)	m ³ (cu. ft.)	Heaped	0.245 (8.65)	
		Struck	0.185 (6.53)	
Slew speed	min ⁻¹ (rpm)	10.3 (10.3)		
Travel speed	km/h (mph)	Rubber crawlers	1st	2.6 (1.62)
			2nd	5.0 (3.11)
		Steel crawlers	1st	2.5 (1.55)
			2nd	4.8 (2.98)
Gradeability	(degrees)	35		
Ground pressure	kPa (psi)	Rubber crawlers	38.1 (5.53)	39.0 (5.66)
		Steel crawlers	39.6 (5.74)	40.5 (5.87)
Noise level	dB (A)	Sound power level	L _{WA} 99	
		Sound pressure level	L _{pA} 74	
ENGINE				
Manufacturer and model		ISUZU AU-4JJ1TYSB-03		
Rated output	kW/min ⁻¹ (hp/rpm)	51.4/2000 (68.9/2000)		
Displacement	ml (cu.in.)	2999 (183)		
Starter	V-kW	12-2.5		
Alternator	V-kW	12-1.32		
Battery	V-A·h	12-72		



MACHINE DIMENSIONS

Mono boom

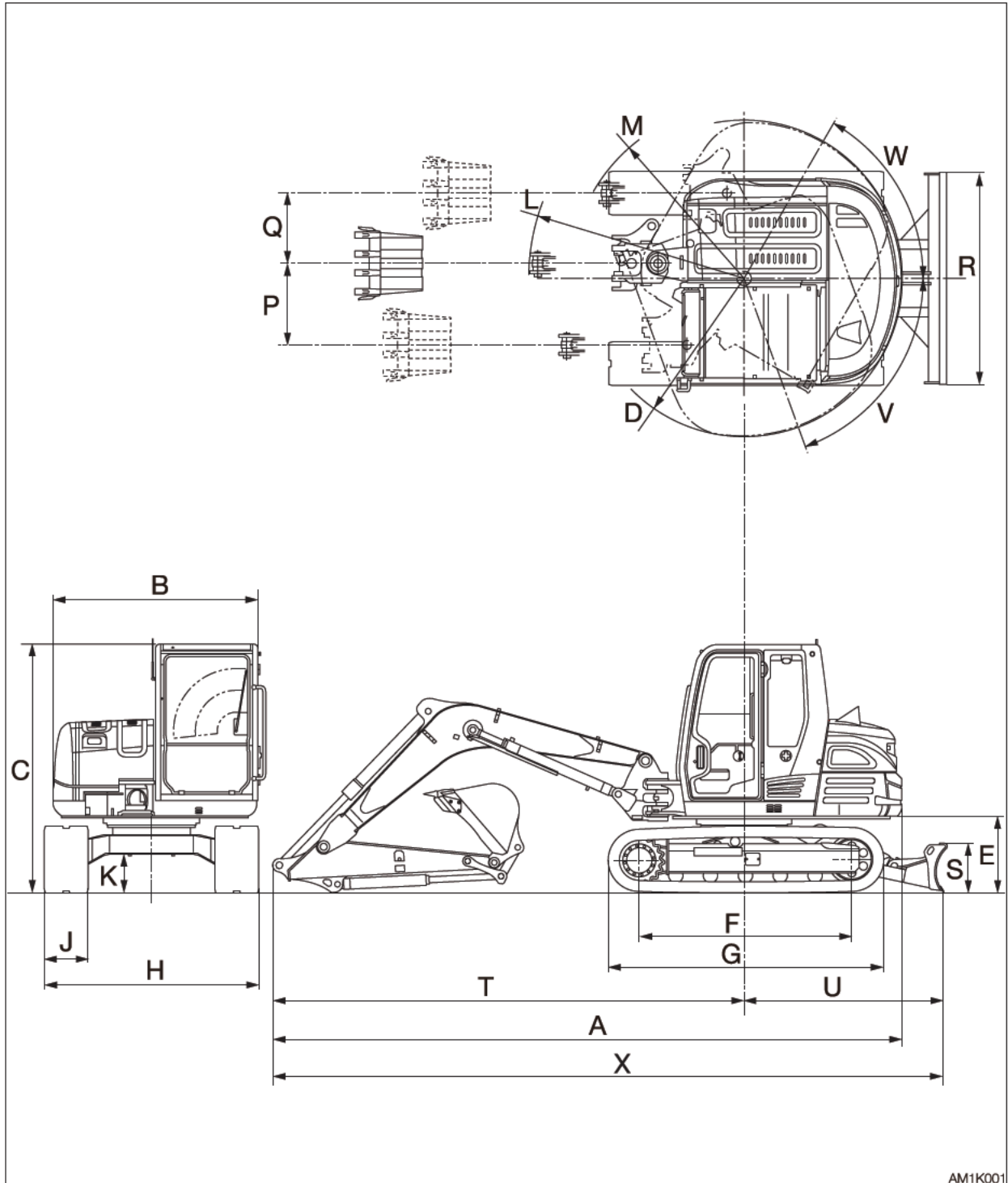

AM1K001



SPECIFICATIONS
MACHINE DIMENSIONS

<TB285/TB290>

Mono boom

Unit: mm (inch)

	Item	Standard arm	Middle arm	Long arm
		Rubber crawlers		
A	Overall length	6530 (257.1)	6575 (258.9)	6660 (262.3)
B	Upperstructure overall width	2140 (84.3)	←	←
C	Overall height	2565 (100.9) 2560 (100.8)*	←	←
D	Slew radius	1650 (65)	←	←
E	Clearance height under upperstructure	785 (30.9) 760 (29.9)*	←	←
F	Crawler base	2210 (87) 2180 (85.8)*	←	←
G	Crawler overall length	2855 (112.4) 2830 (111.4)*	←	←
H	Crawler overall width	2200 (86.6)	←	←
J	Crawler shoe width	450 (17.7)	←	←
K	Ground clearance of undercarriage	385 (15.1) 360 (14.2)*	←	←
L	Minimum radius of equipment and attachment	2240 (88.2)	2360 (92.9)	2495 (98.2)
M	Minimum radius of equipment at maximum front offset	1810 (71.3)	1910 (75.3)	2030 (79.9)
P	Offset distance of bucket (Left)	845 (33.3)	←	←
Q	Offset distance of bucket (Right)	730 (28.7)	←	←
R	Dozer blade width	2200 (86.6)	←	←
S	Dozer blade height	500 (19.7)	←	←
T	Front distance to axis of rotation	4890 (192.5)	4935 (194.3)	5020 (197.7)
U	Dozer blade distance to axis of rotation	2055 (80.9) 2060 (81.1)*	←	←
V	Boom swing angle (Left)	70°	←	←
W	Boom swing angle (Right)	60°	←	←
X	Overall length (dozer blade at rear)	6945 (273.4)	6990 (275.1)	7075 (278.6)

*: With steel crawlers



SPECIFICATIONS
MACHINE DIMENSIONS

2-Piece boom

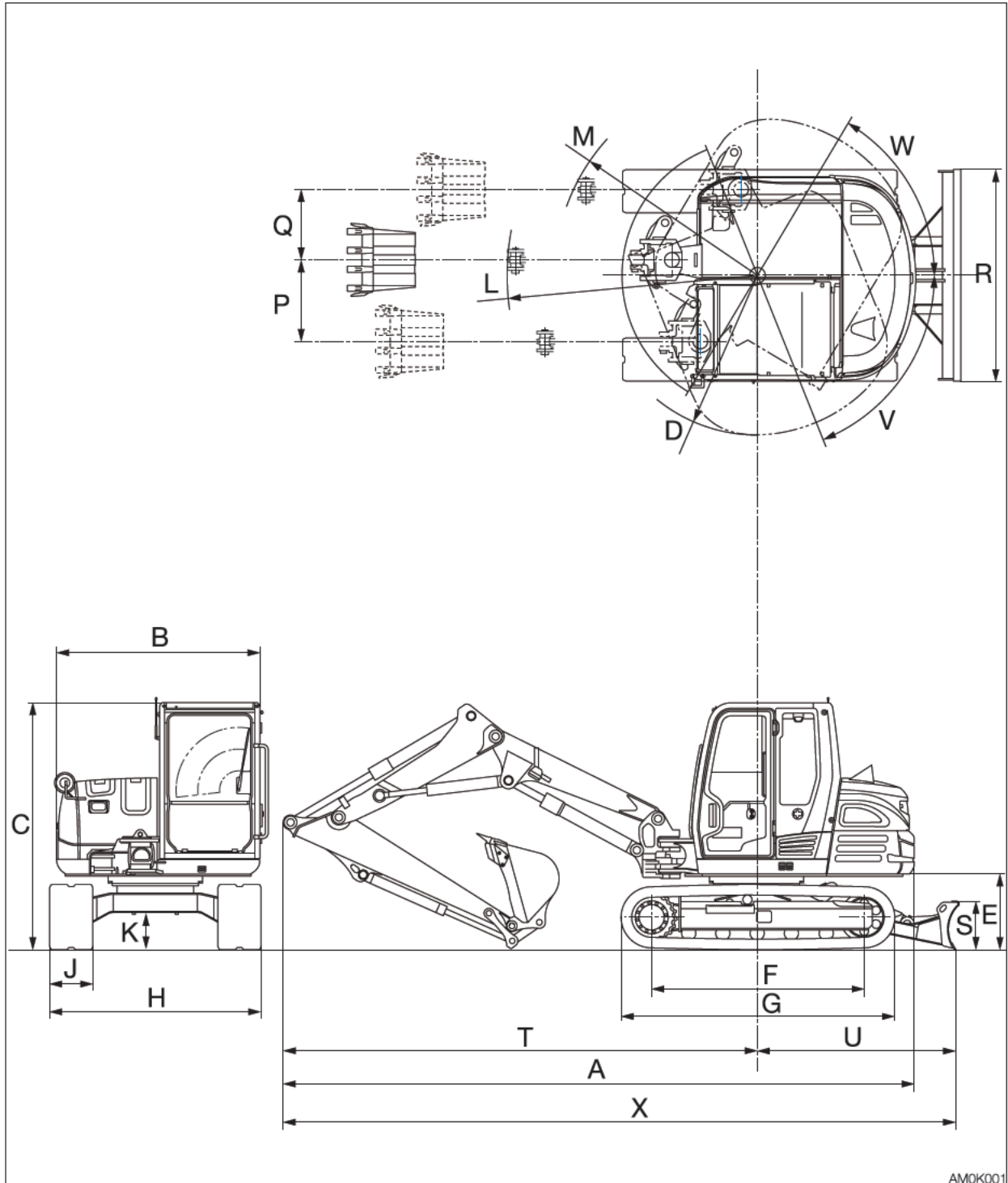

AM0K001



SPECIFICATIONS
MACHINE DIMENSIONS

<TB285/TB290>

2-Piece boom

Unit: mm (inch)

	Item	Rubber crawlers
A	Overall length	6550 (257.8)
B	Upperstructure overall width	2140 (84.3)
C	Overall height	2565 (100.9) 2560 (100.8)*
D	Slew radius	1650 (65)
E	Clearance height under upperstructure	785 (30.9) 760 (29.9)*
F	Crawler base	2210 (87) 2180 (85.8)*
G	Crawler overall length	2855 (112.4) 2830 (111.4)*
H	Crawler overall width	2200 (86.6)
J	Crawler shoe width	450 (17.7)
K	Ground clearance of undercarriage	385 (15.1) 360 (14.2)*
L	Minimum radius of equipment and attachment	2580 (101.6)
M	Minimum radius of equipment at maximum front offset	2105 (82.9)
P	Offset distance of bucket (Left)	850 (33.4)
Q	Offset distance of bucket (Right)	730 (28.7)
R	Dozer blade width	2200 (86.6)
S	Dozer blade height	500 (19.7)
T	Front distance to axis of rotation	4910 (193.2)
U	Dozer blade distance to axis of rotation	2055 (80.9) 2060 (81.1)*
V	Boom swing angle (Left)	70°
W	Boom swing angle (Right)	60°
X	Overall length (dozer blade at rear)	6960 (274.1)

*: With steel crawlers



OPERATING RANGES

Mono boom

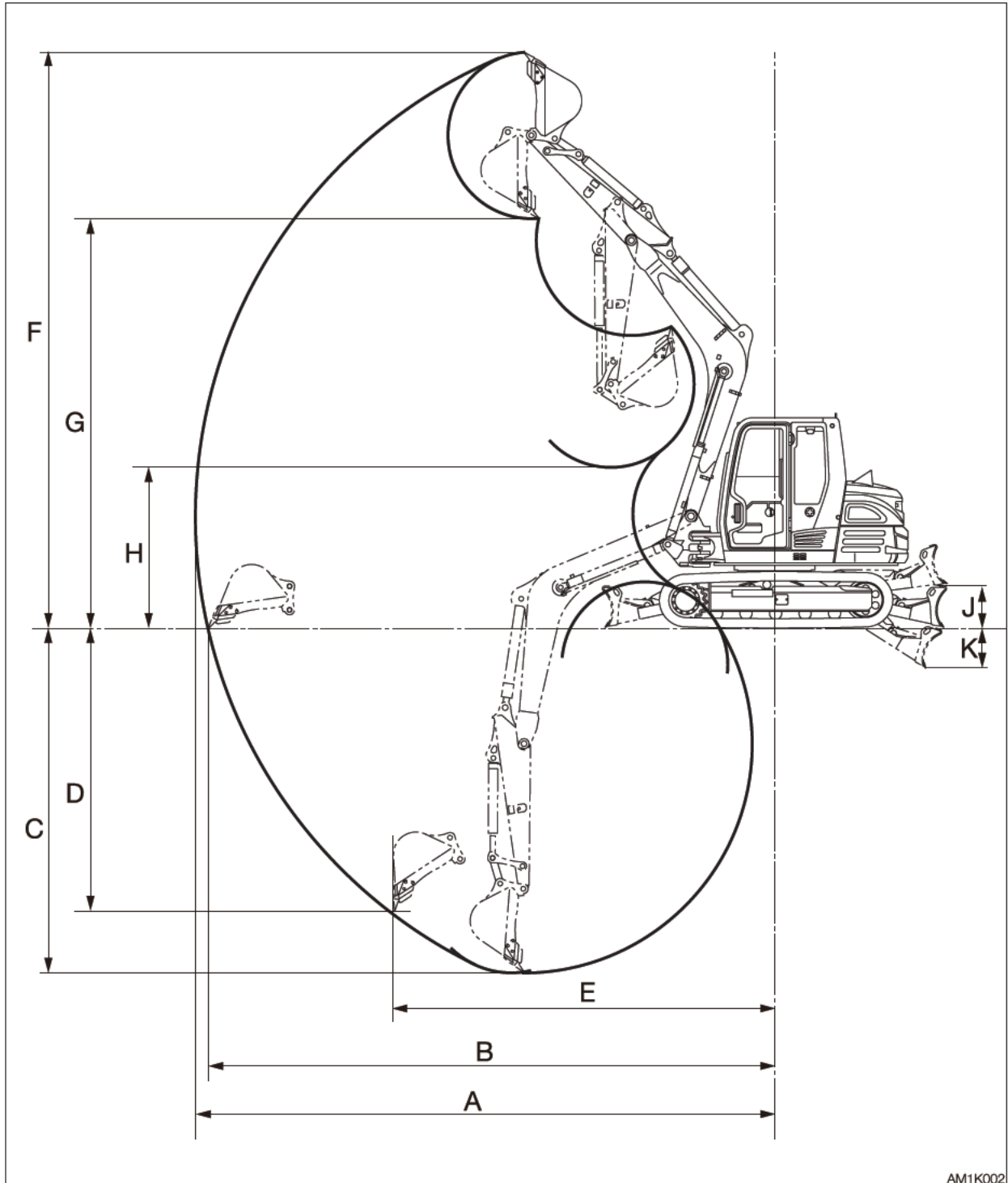



SPECIFICATIONS
OPERATING RANGES

<TB285/TB290>

Mono boom

Unit: mm (inch)

	Item	Standard arm	Middle arm	Long arm
		Rubber crawlers		
A	Maximum reach	7105 (279.6)	7275 (286.3)	7435 (292.7)
B	Maximum reach at ground reference plane	6950 (273.6)	7125 (280.5)	7290 (287.0)
C	Maximum digging depth	4220 (166.1)	4400 (173.2)	4570 (179.9)
D	Maximum vertical digging depth	3455 (136.1)	3635 (143.1)	3805 (149.9)
E	Reach at maximum vertical digging depth	4685 (184.4)	4720 (185.8)	4755 (187.1)
F	Maximum height of cutting edge	7045 (277.3)	7175 (282.5)	7305 (287.5)
G	Maximum dumping height	5010 (197.2)	5140 (202.4)	5270 (207.4)
H	Minimum dumping height	1960 (77.2)	1795 (70.7)	1650 (65.0)
J	Dozer blade maximum lifting	520 (20.4)	←	←
K	Dozer blade maximum lowering	490 (19.3)	←	←

*: With an angle dozer blade



SPECIFICATIONS
OPERATING RANGES

2-Piece boom

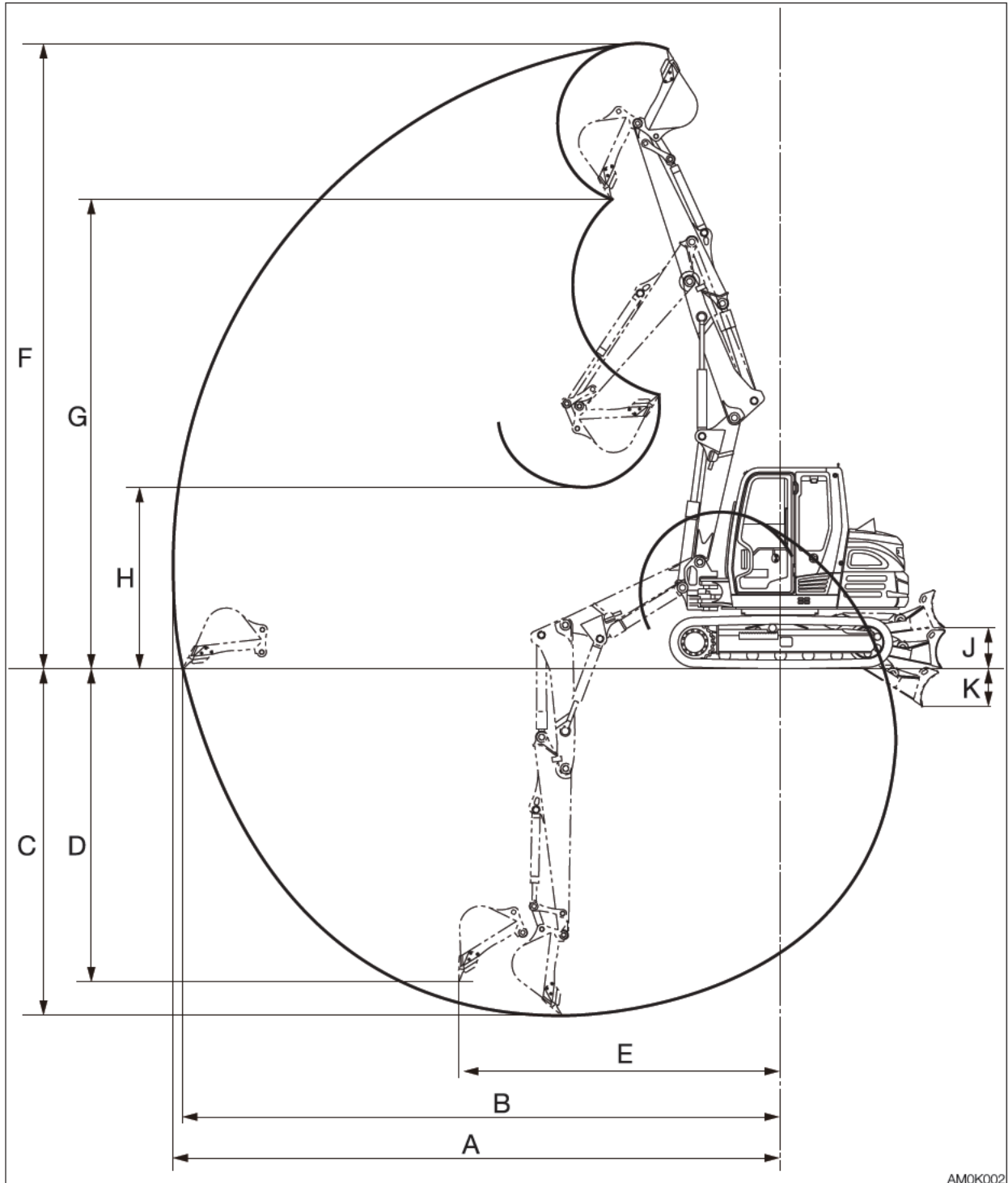



SPECIFICATIONS
OPERATING RANGES

<TB285/TB290>

2-Piece boom

Unit: mm (inch)

	Item	Rubber crawlers
A	Maximum reach	7700 (303.1)
B	Maximum reach at ground reference plane	7560 (297.6)
C	Maximum digging depth	4445 (175)
D	Maximum vertical digging depth	4015 (158.1)
E	Reach at maximum vertical digging depth	4045 (159.3)
F	Maximum height of cutting edge	7980 (314.2)
G	Maximum dumping height	6005 (236.4)
H	Minimum dumping height	2310 (90.9)
J	Dozer blade maximum lifting	520 (20.4)
K	Dozer blade maximum lowering	490 (19.3)

*: With an angle dozer blade

MEMO



LIFTING CAPACITIES

Rated lift capacity chart

- The loads in the charts do not exceed 87% of hydraulic lift capacity or 75% of tipping load.
- Figures marked with an asterisk (*) are hydraulically-limited capacities.
- The mass of slings and any other lifting devices shall be deducted from the rated load to determine the net load that may be lifted.
- The load point is the bucket hinge pin, and the bucket posture is with the standard bucket completely retracted under the arm.
- Unit: daN (lbs)

Load hooking system

A load hooking system must be provided with the following capabilities.

1. A system which can withstand twice the rated lift capacity no matter at what position the load is applied.
2. A system that poses no risk of the lifted load falling from the hooking device. For example, equipped with a hook slippage prevention device.
3. A system that poses no risk of the hooking system slipping from the hoe attachment.

WARNING

- Do not attempt to lift or hold any load that is greater than these rated values at their specified load radii and height.
- The rated lift capacities are based on the machine being level and situated on a firm supporting surface. For safe lifting, the operator is expected to make due allowance for the particular job conditions such as soft or uneven ground, non-level condition, load to the machine sides, hazardous conditions, experience of personnel, etc. The operator and other personnel should fully acquaint themselves with the operator's manual furnished by the manufacturer before operating this machine. When operating the machine, the safety rules of the equipment must also be followed.
- Do not travel while lifting a load; It is very dangerous.



SPECIFICATIONS
LIFTING CAPACITIES

Standard arm <TB285>

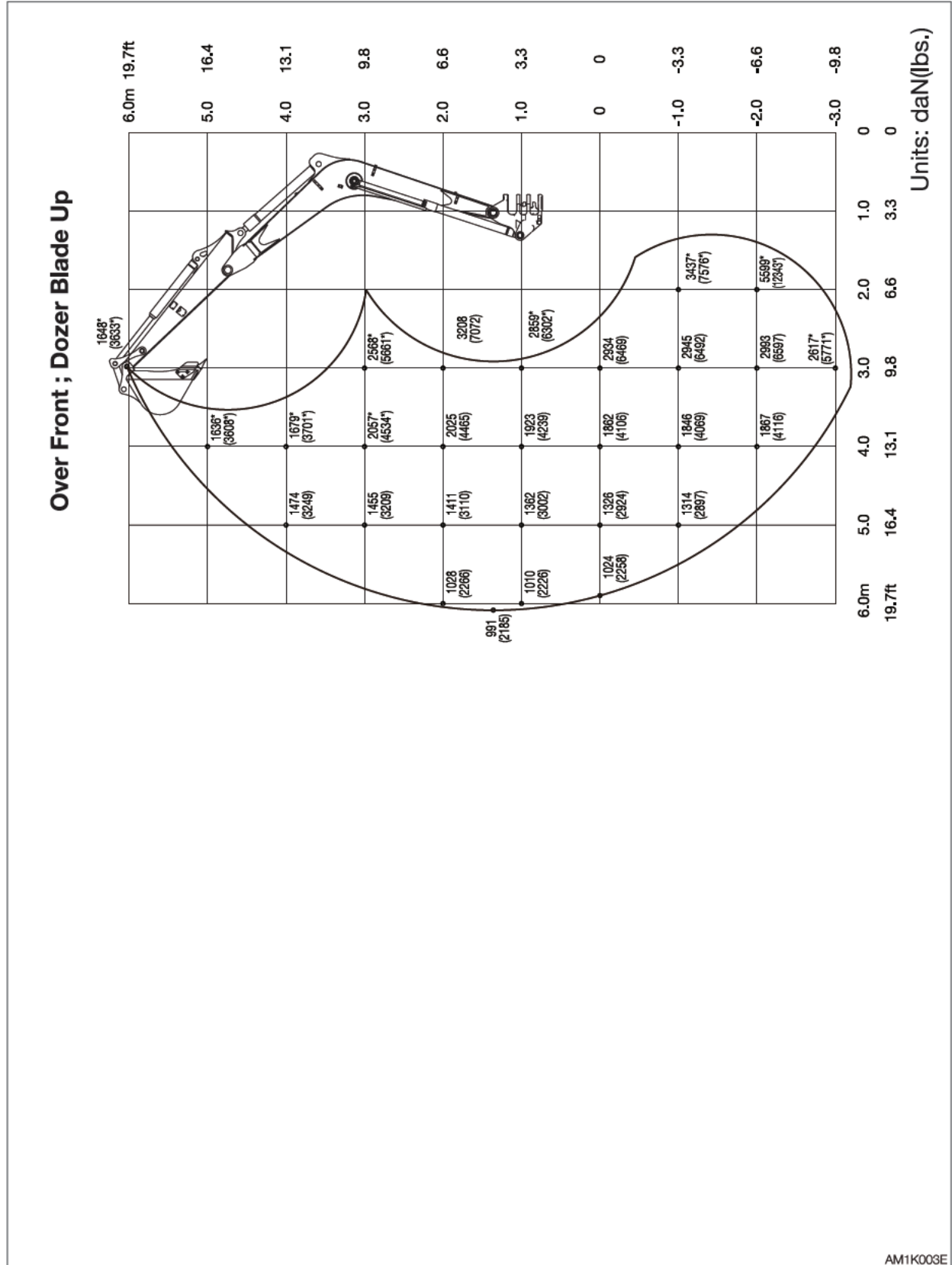



SPECIFICATIONS
LIFTING CAPACITIES

Standard arm <TB285>

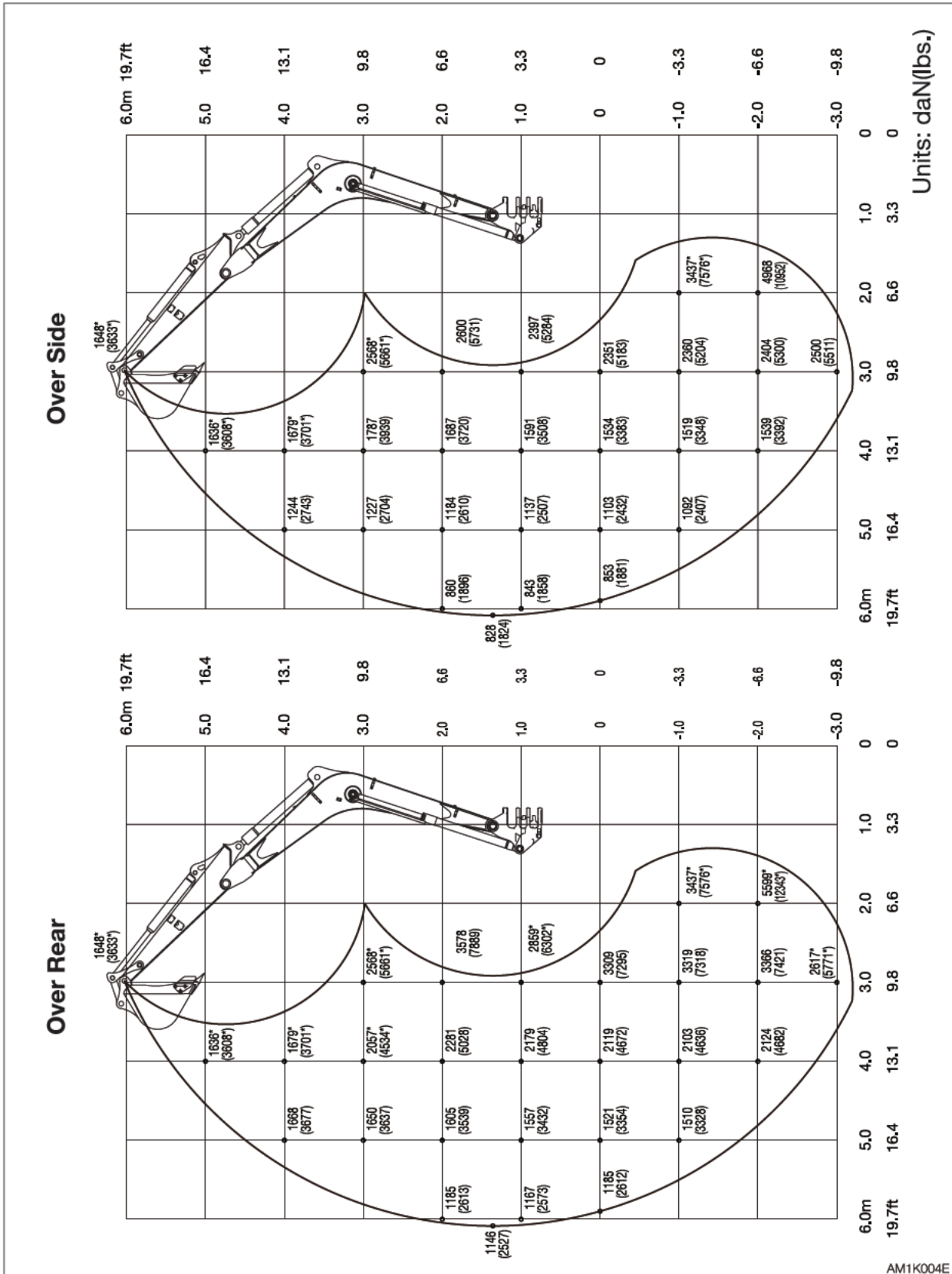



SPECIFICATIONS
LIFTING CAPACITIES

Middle arm <TB285>

Over Front ; Dozer Blade Up

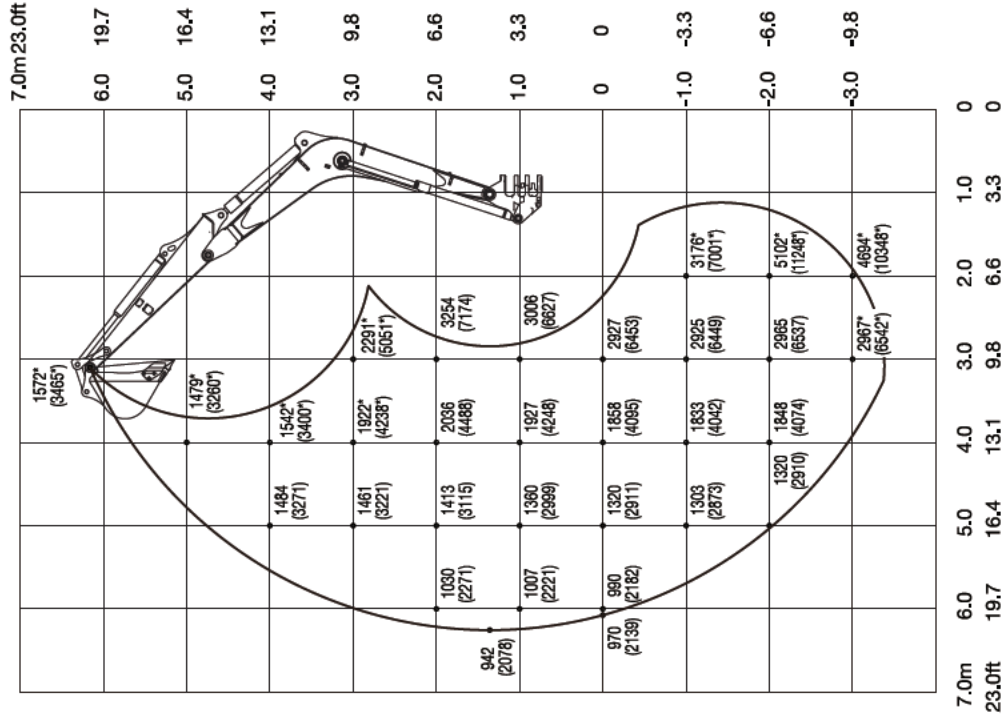

Units: daN(lbs.)



SPECIFICATIONS
LIFTING CAPACITIES

Long arm <TB285>

Over Front ; Dozer Blade Up

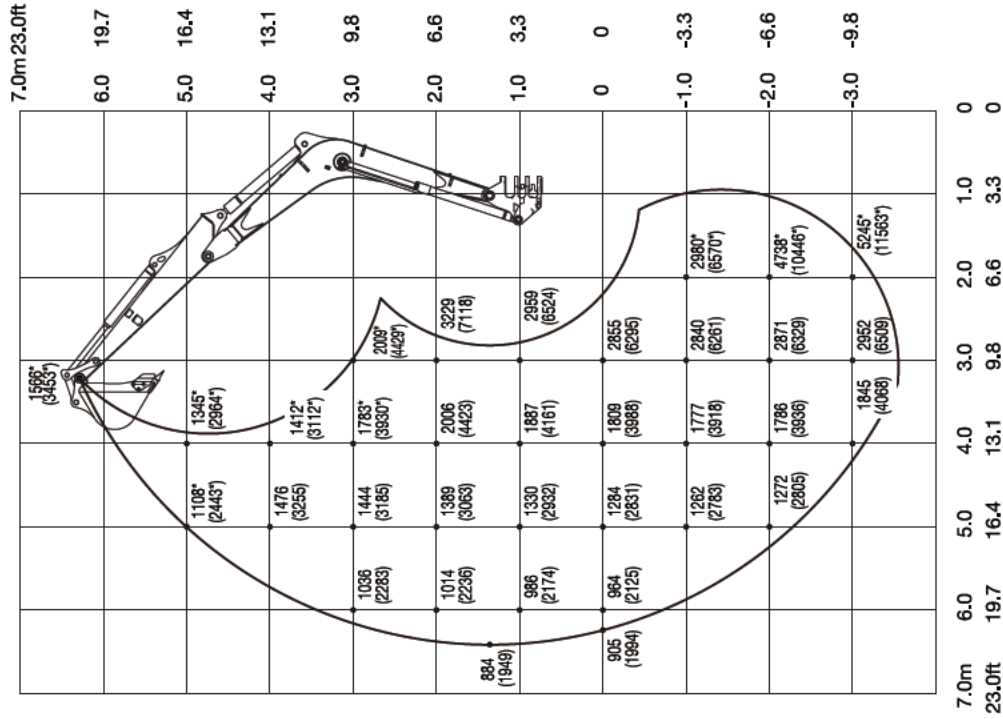

Units: daN(lbs.)



SPECIFICATIONS
LIFTING CAPACITIES

Long arm <TB285>

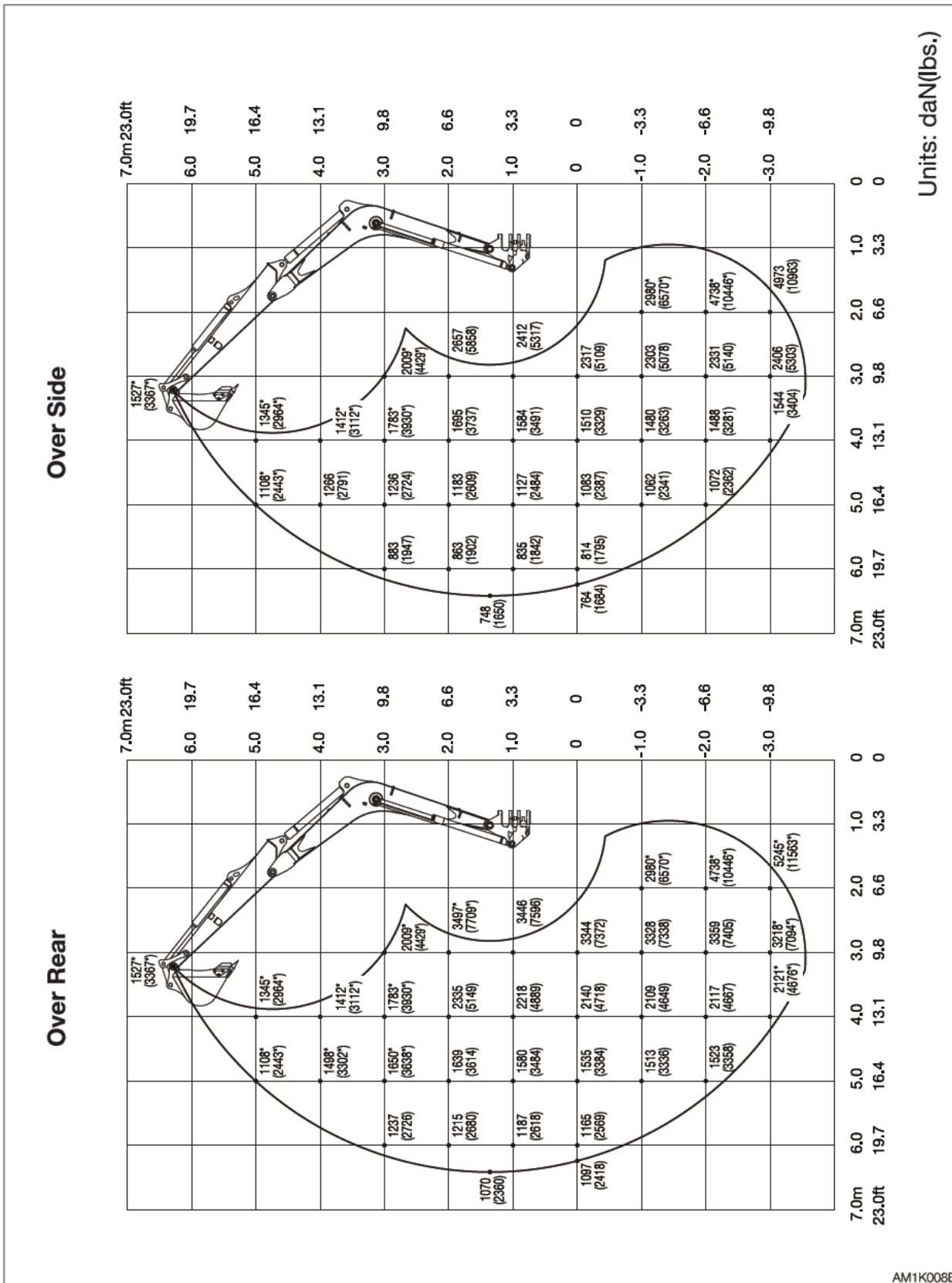



SPECIFICATIONS
LIFTING CAPACITIES

Standard arm <TB290>

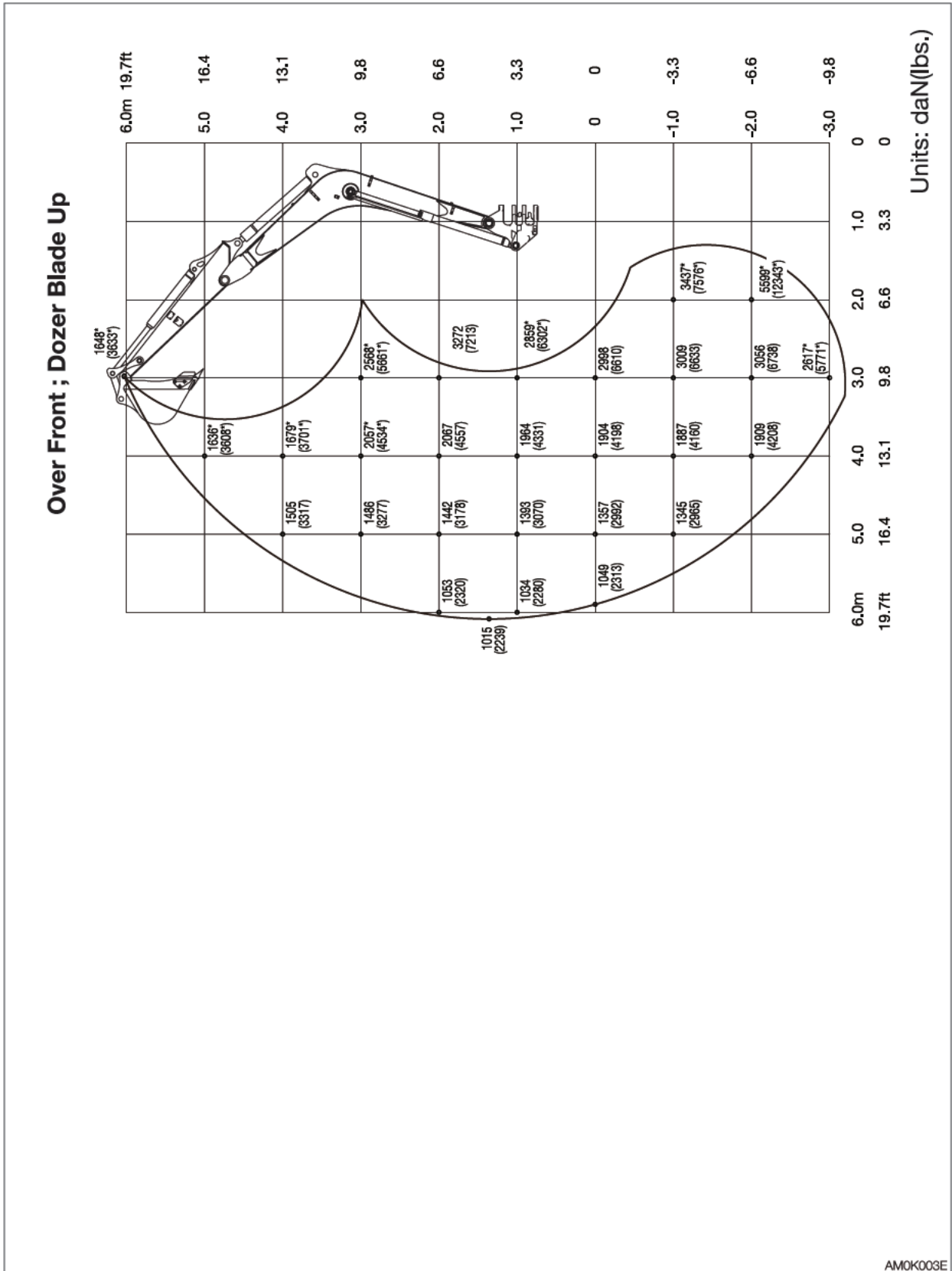

AM0K003E



SPECIFICATIONS
LIFTING CAPACITIES

Standard arm <TB290>

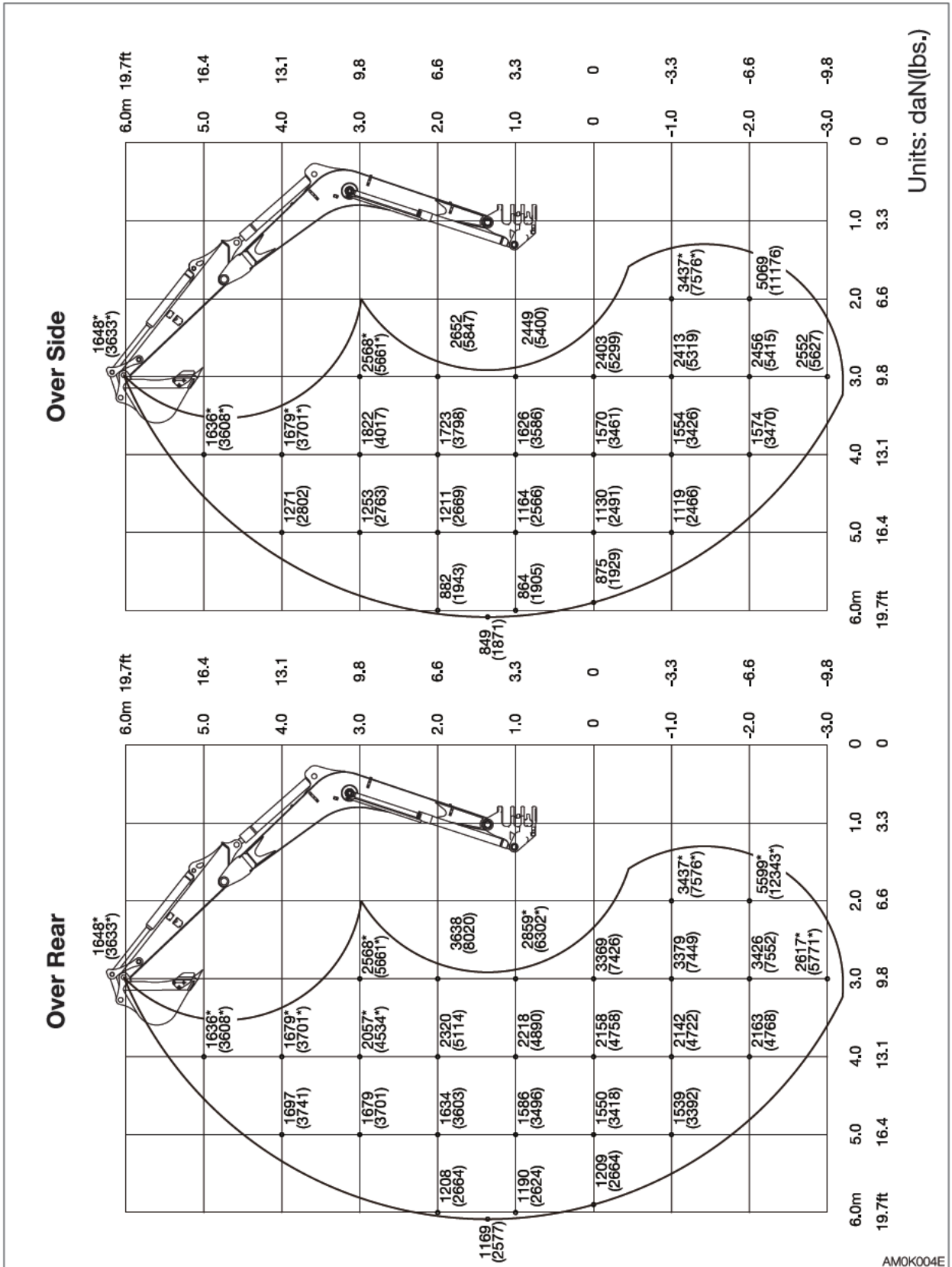



SPECIFICATIONS
LIFTING CAPACITIES

Middle arm <TB290>

Over Front ; Dozer Blade Up

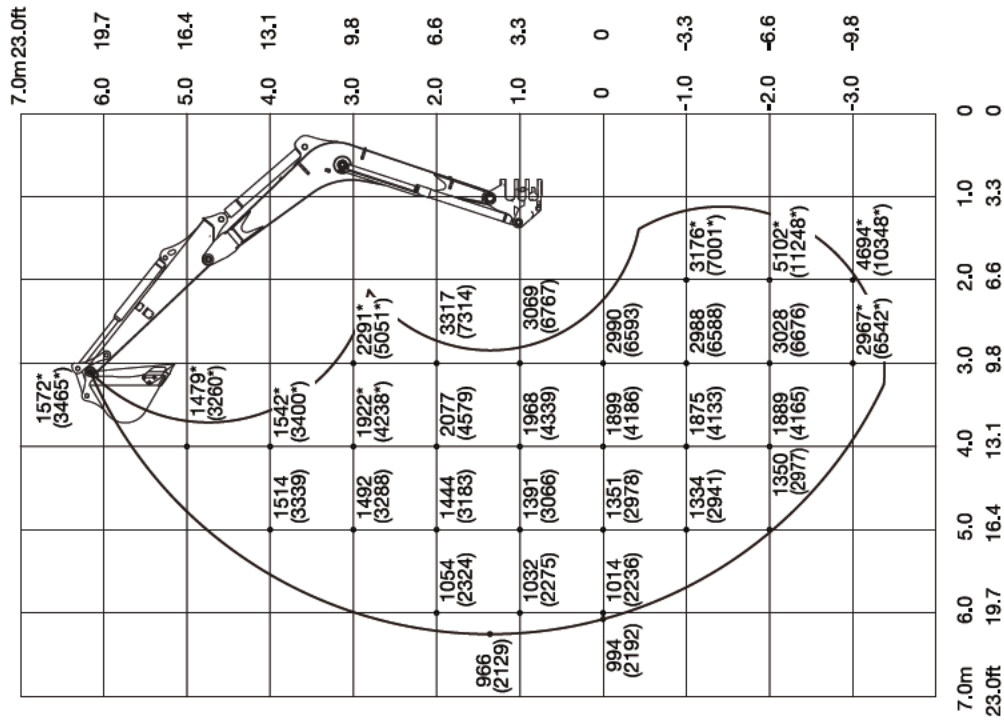

Units: daN(lbs.)

AM0K005E



SPECIFICATIONS
LIFTING CAPACITIES

Middle arm <TB290>

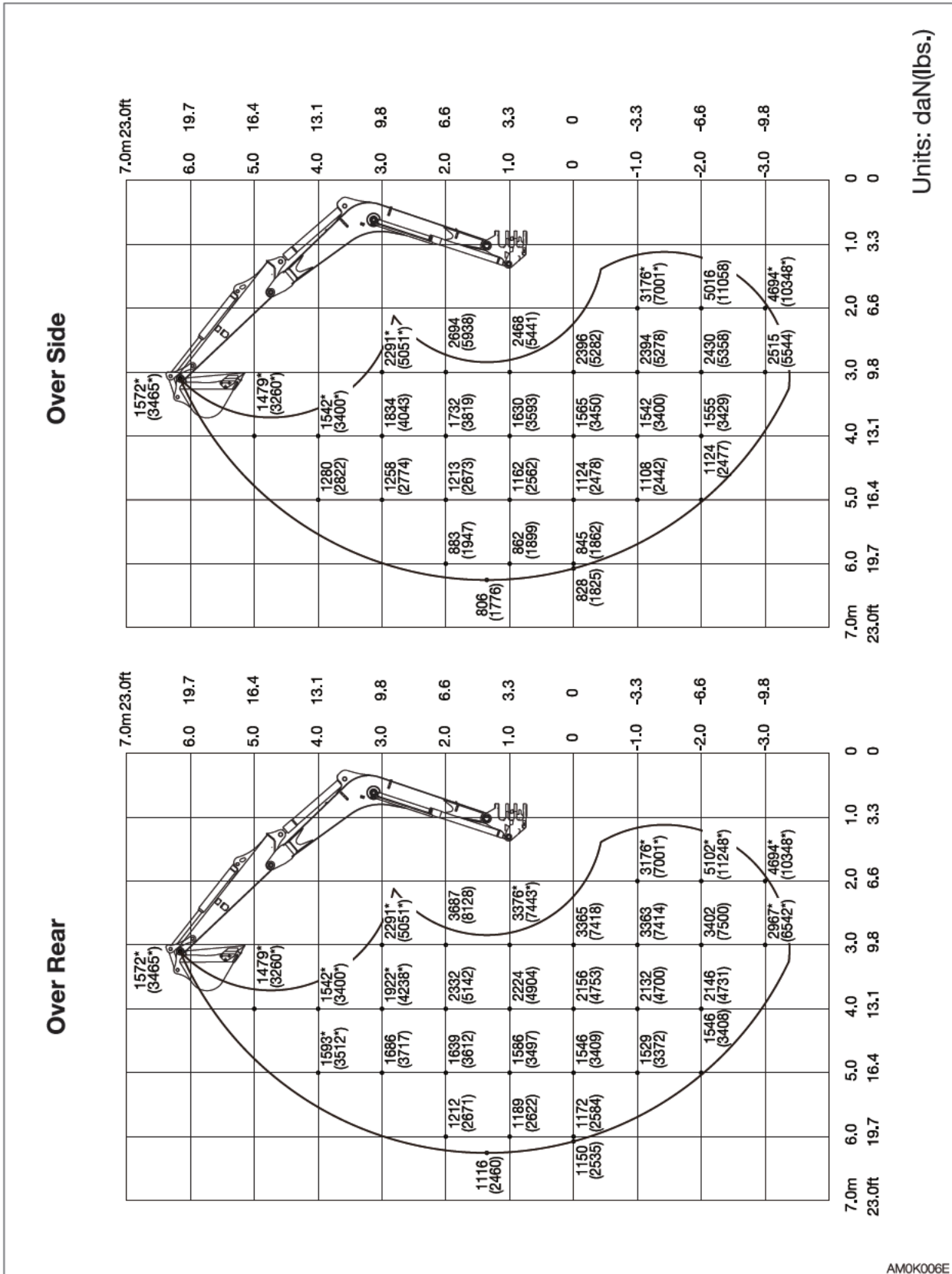



SPECIFICATIONS
LIFTING CAPACITIES

Long arm <TB290>

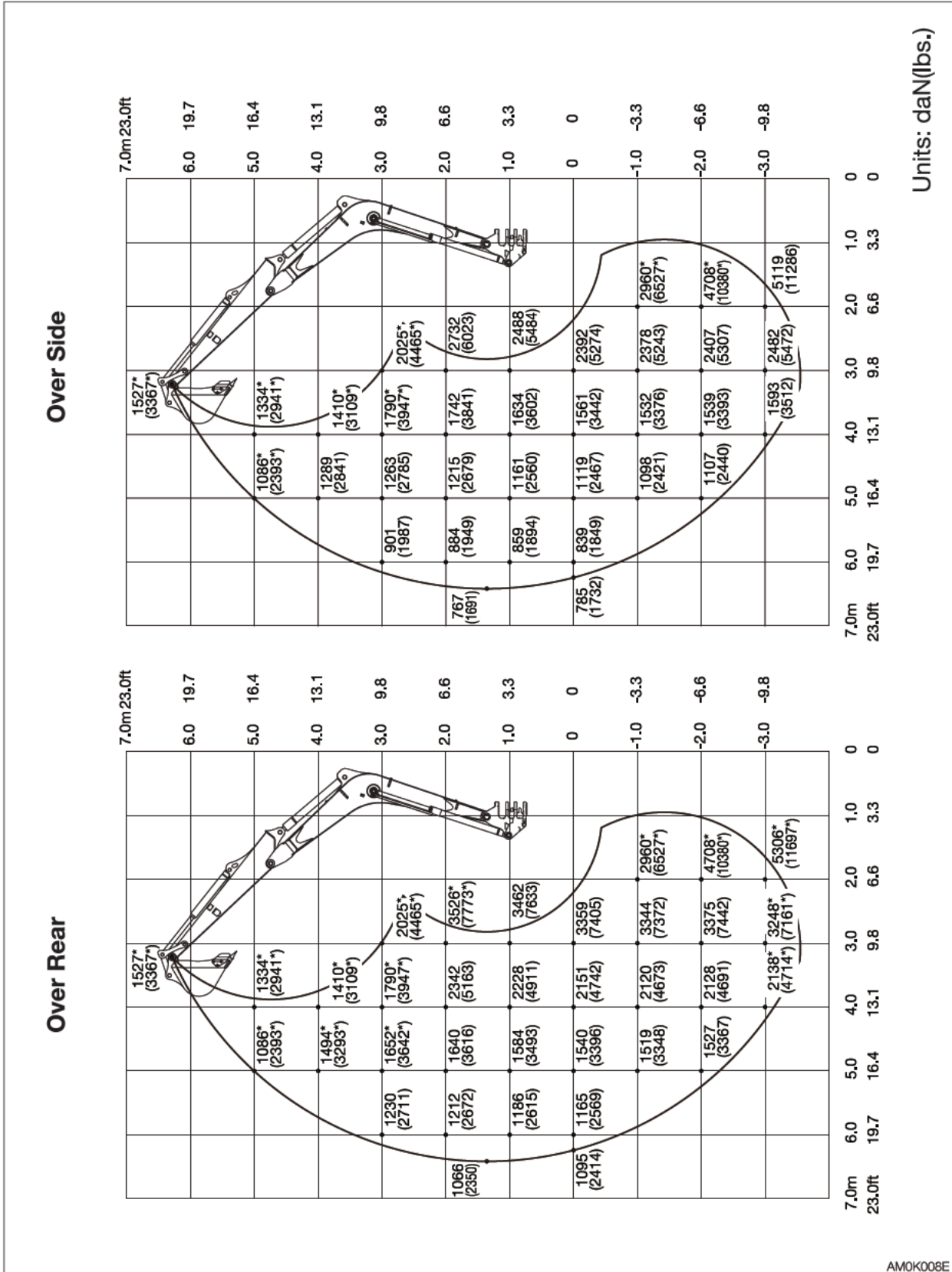



SPECIFICATIONS
LIFTING CAPACITIES

2-Piece boom <TB285> Equipped with Extra weight

Over Front ; Dozer Blade Up

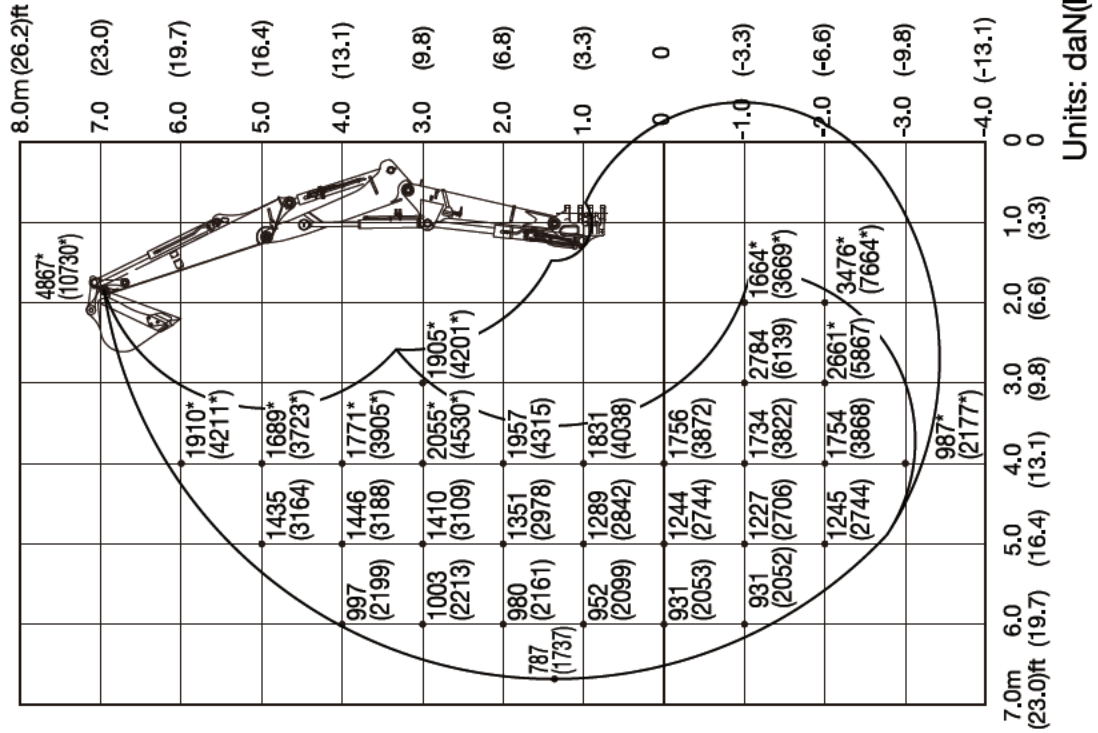

Units: daN(lbs.)



SPECIFICATIONS
LIFTING CAPACITIES

2-Piece boom <TB285> Equipped with Extra weight

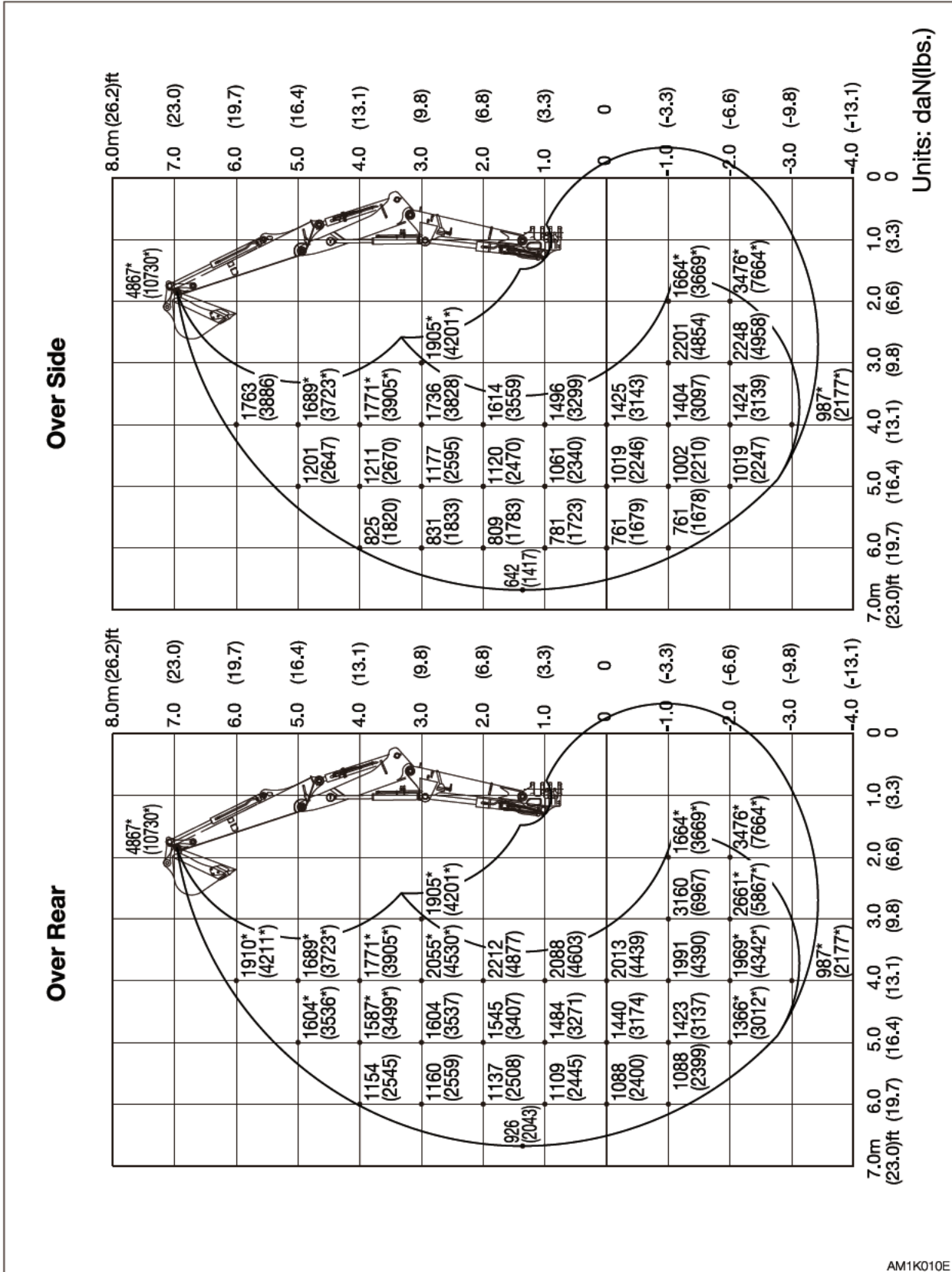



SPECIFICATIONS
LIFTING CAPACITIES

2-Piece boom <TB290> Equipped with Extra weight

Over Front ; Dozer Blade Up

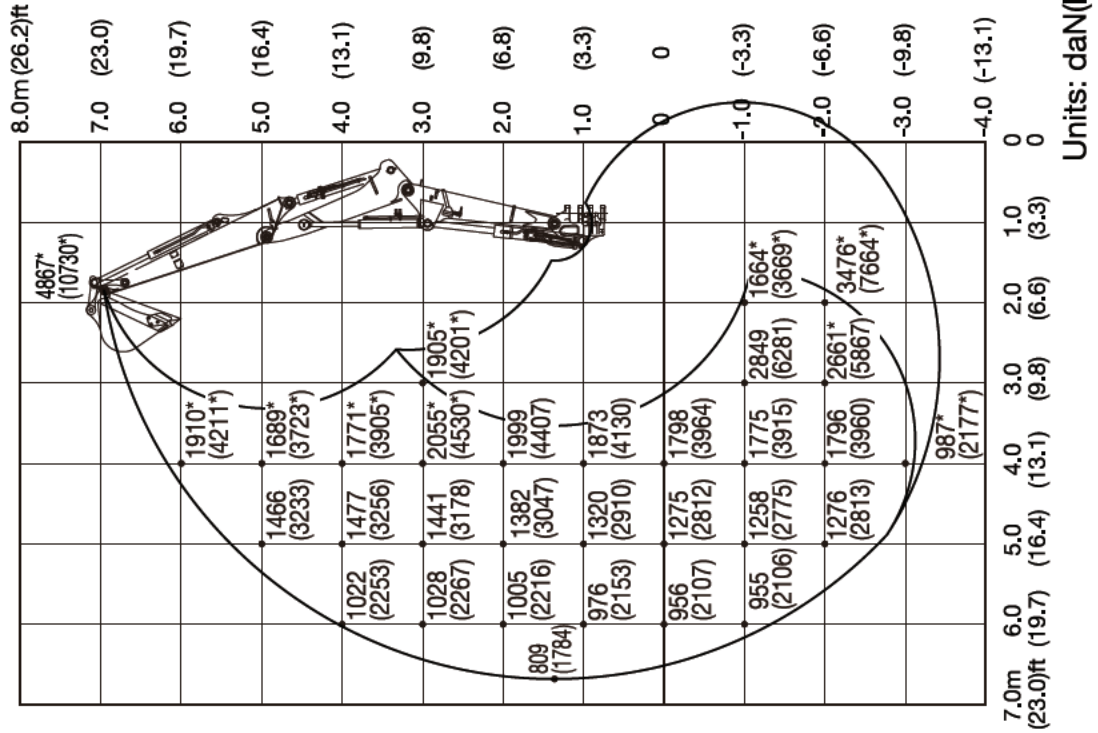

Units: daN(lbs.)



SPECIFICATIONS
LIFTING CAPACITIES

2-Piece boom <TB290> Equipped with Extra weight

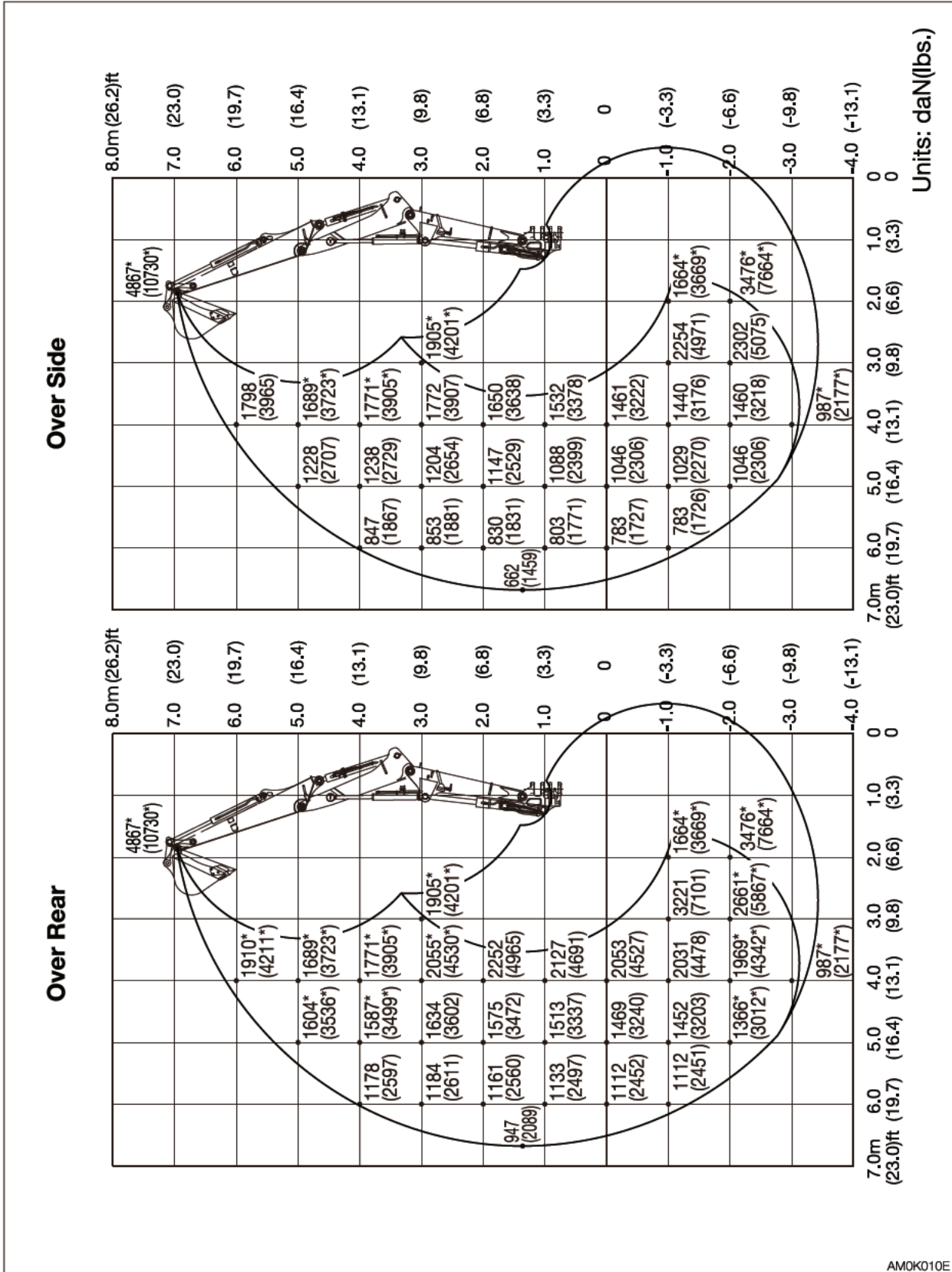

OPTIONS



GENERAL PRECAUTIONS

SAFETY PRECAUTIONS

 **WARNING**

When removing or installing an attachment or optional part, take the following precautions.

- Consult with Takeuchi before installing an optional attachment.
- Do not use any attachments not approved by Takeuchi. Doing so may cause safety problems. Or, it may adversely affect the machine's operation or service life.
- We will not be held responsible for any injuries, accidents or damage to its products caused by the use by a non-approved attachment.
- Select a firm, level work area. Also, be sure to park in a well ventilated place.
- Clear obstacles and dangerous objects, and clean up spilled fuel immediately.
- When hoisting, be sure to designate a person to act as a signalman. Follow the instructions of the signalman regarding the procedure and measures.
- When it is necessary to temporarily place a heavy object or an attachment on the ground during removal or installation, be sure to place it in a stable position.
- Keep everyone out of the area when hoisting. There is a hazard of objects falling or contacting with people in the area.
- Use a crane to move heavy objects (25 kg (55 lb.) or greater).
- Before removing a heavy object, be sure to put a support to it. When lifting with a crane, pay attention to the center of gravity of the load to keep the machine in balance.
- Do not operate the machine while the load is lifted by a crane stand.

- Use the proper procedure when mounting a boom or arm; otherwise serious damage could result. Consult your sales or service dealer for help.
-

CAUTIONS WHEN INSTALLING ATTACHMENTS

Be sure to perform a test operation after an optional or other special attachment has been replaced. Inspect the hydraulic oil level and recharge it as necessary. Consult your sales or service dealer for detailed procedures on installing/removing attachments.



CAUTIONS WHEN OPERATING ATTACHMENTS

WARNING

Long attachments reduce stability of the machine. The machine may tip over if it loses the balance when traveling or slewing on slopes.

Never perform the operations listed below as they are extremely dangerous.

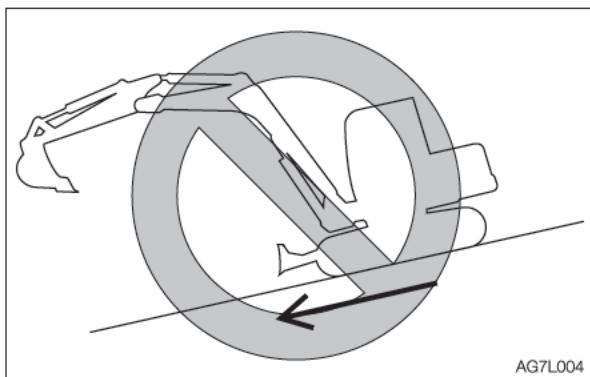

- Traveling down the slopes with the attachment raised

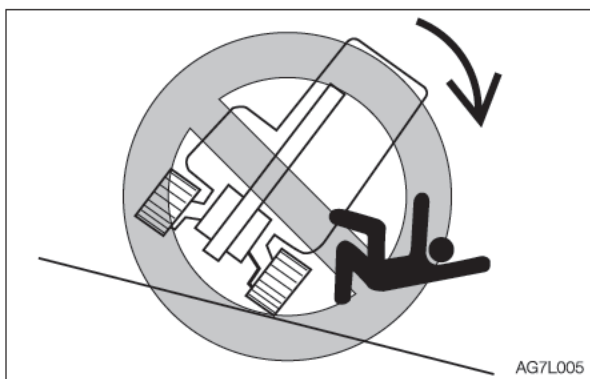

- Traveling across slopes

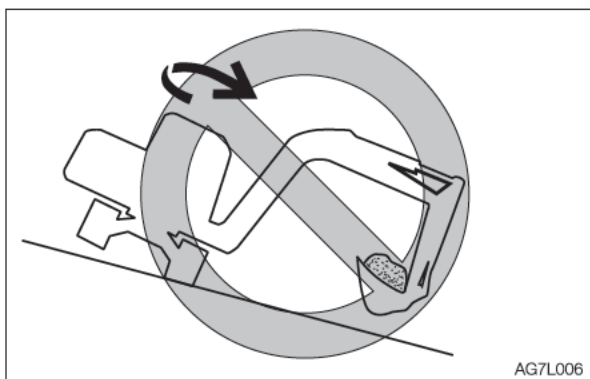

- Slewing on slopes
- If there is a heavy attachment is installed, the machine takes longer distance than usual to come to a complete stop when the stopping operation is performed. Carefully judge the distance so as not to bump into an object around the machine. Keep a safe distance from surrounding obstacles. When a heavy attachment is installed, natural drop (the gradual dropping of the attachment under its own weight when it is stopped in midair) increases.
- The machine can tip over more easily in the lateral direction than in the longitudinal direction.
 - Do not slew sideways with a heavy load at the how attachment. In particular, do not slew sideways on slopes.
 - The attachment is heavier for machines equipped with breakers or crushers than for machines equipped with the standard bucket. Do not operate such machines sideways, especially digging downhill.
- When a long arm is installed, the operating range increases. Carefully judge the distance so as not to bump into an object around the machine. Keep a safe distance from surrounding obstacles.



ATTACHMENT COMBINATION TABLE

The table below shows which bucket should be installed when the machine is using a standard arm, middle arm or long arm. Select a proper bucket by following the table.

⚠ WARNING

- Consult with Takeuchi before installing an optional attachment.
- Do not use any attachments not approved by Takeuchi. Doing so may cause safety problems. Or, it may adversely affect the machine's operation or service life.
- We will not be held responsible for any injuries, accidents or damage to its products caused by the use by a non-approved attachment.
- The swing stopper must be installed when a bucket wider than a 750W (standard) bucket is installed. Failure to do so may result in the bucket hitting the machine body.
- Install the lightweight weight or wide width steel crawler if the long arm is installed.

√ :Can be used.

Δ :Can be used only for light operations (digging and loading of dry and loose soil or mud)

— :Cannot be used.

Total bucket mass = Bucket mass + Heaped bucket load (specific gravity: 1.8)

Bucket	Rated capacity m ³ (cu.yd.)	Bucket cutting width mm (inch)	Standard arm 1780 mm (70 in.)	Middle arm 1960 mm (77 in.)	Long arm 2130 mm (84 in.)
430W (no side cutter)	0.14 (0.18)	430 (16.9)	√	√	√
500 W	0.14 (0.18)	500 (19.7)	√	√	√
650 W	0.20 (0.26)	650 (25.6)	√	√	√
750 W (S.T.D.)	0.25 (0.33)	750 (29.5)	√	√	—
3-hole bucket	0.26 (0.34)	610 (24.0)	√	—	—
Total bucket weight= Within 657 kg (1448 lb.)		Within 750 (29.5)	√	—	—
Hydraulic Breaker (TKB-401)			√	—	—



SELECTING A LEVER PATTERN

The operating pattern of the left and right operating levers can be changed.

WARNING

Before starting the engine, check the selector to see which operating pattern the left and right operating levers are set.

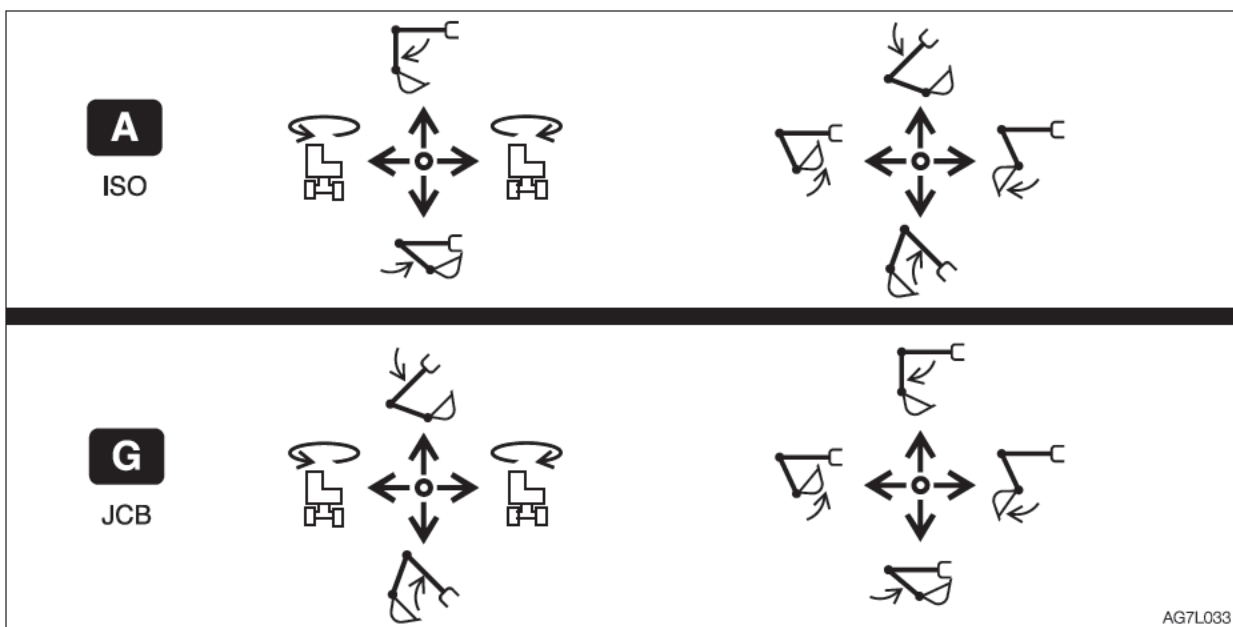

SWITCHING THE LEVER PATTERN

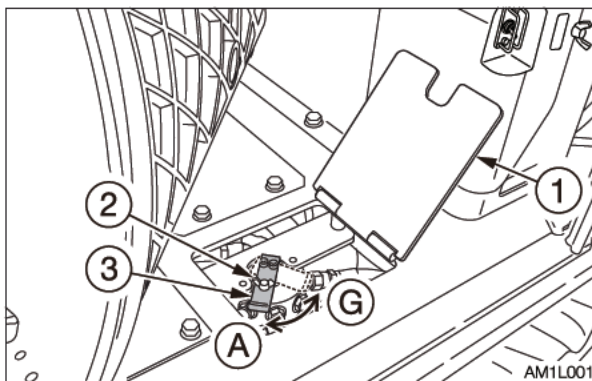

(A) : ISO pattern
(G) : JCB pattern

1. Park the machine on a flat and rigid ground, and stop the engine.
2. Fully open the cab door and fix it in place.
3. Remove the floor mat.
4. Open the cover (1).
5. Loosen the wing bolt (2).
6. Turn the selector valve lever (3) to change the pattern.
7. Tighten the wing bolt (2) and fasten the lever (3) in place.
8. Close the cover (1) and return the floor mat back in place.
9. Confirm the lever pattern.



HYDRAULIC BREAKER

For handling of the breaker, read the hydraulic breaker's manual, provided separately.

IMPORTANT: When installing an attachment, make sure that it is appropriate for the machine being used. Contact your sales or service dealer for advice on selecting attachments.

CAUTIONS ON OPERATING

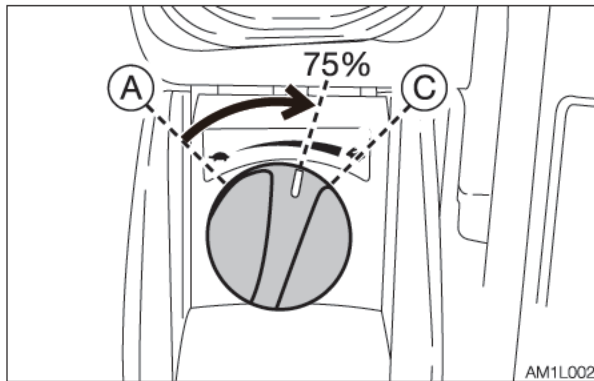

- Start the engine and run it at 75% of the maximum speed.

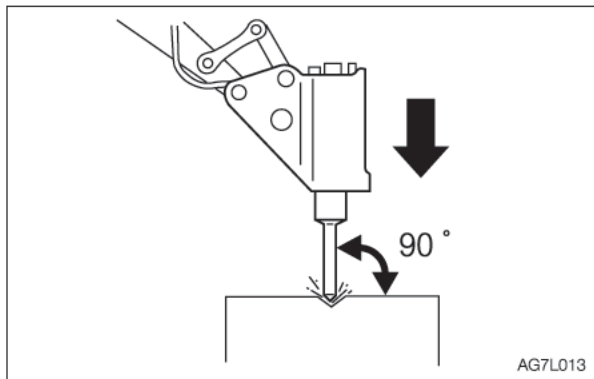

- Pound with the chisel pressed perpendicular to the surface to be pounded.
- When pounding, press the chisel properly against the object to be broken so as to avoid pounding the air.

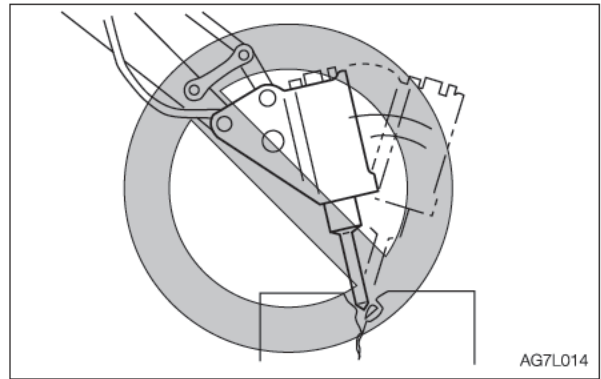

- Do not pry with the chisel or do not pry while pounding.
- Do not move the chisel while pounding.
- Do not pound continuously for over 30 seconds on the same surface.

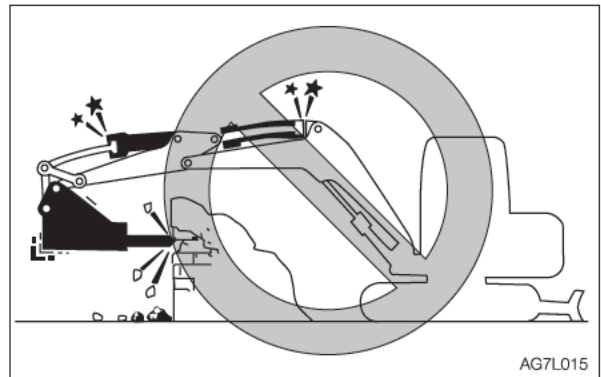

- Do not pound with the cylinder fully extended or retracted (at the stroke end). Leave a margin of at least 50mm(2 in).

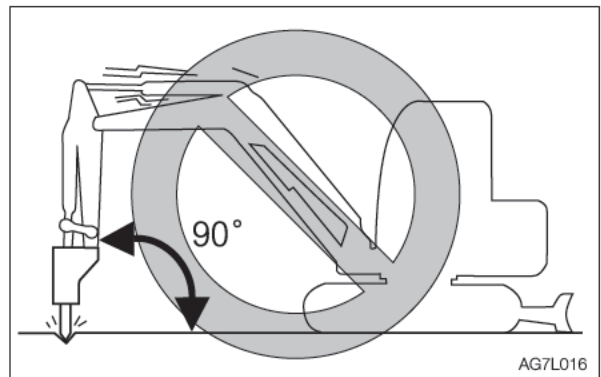

- Do not pound with the arm placed perpendicular to the ground surface.

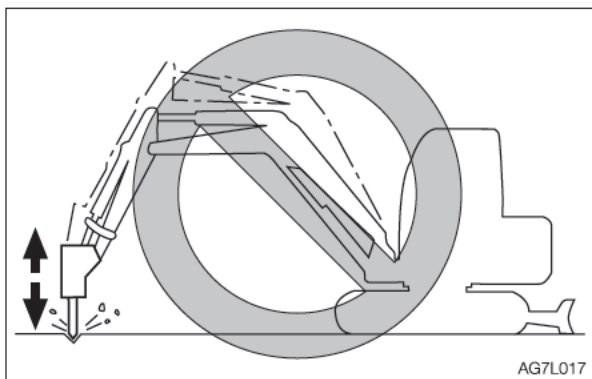

- Do not drop the breaker itself on the object to be broken in order to break it.
- Do not move objects to be broken or rocks with the breaker itself.
- Slew the machine occasionally to cool the engine.
- If a hydraulic hose is vibrating abnormally, nitrogen gas may be leaking from the accumulator. Ask for an inspection early.

REPLACING THE HYDRAULIC OIL REGULARLY

When a hydraulic breaker is used, the oil deteriorates more quickly than that used for a usual operation. Be sure to replace the hydraulic oil and the return filter elements.

- Failure to replace these in time can lead to damage to the machine and the breaker hydraulic system. To improve the service life of the hydraulic systems, be sure to replace the hydraulic oil and return filter element after the number of hours shown on the diagram below.
- When replacing the hydraulic oil, clean the suction strainer.

Replacement interval (hours)

Item	Hydraulic oil	Filter element
1st time	—	25
2nd time	—	100
Periodically	1200 (600)	200

When the breaker operating ratio is 100%.

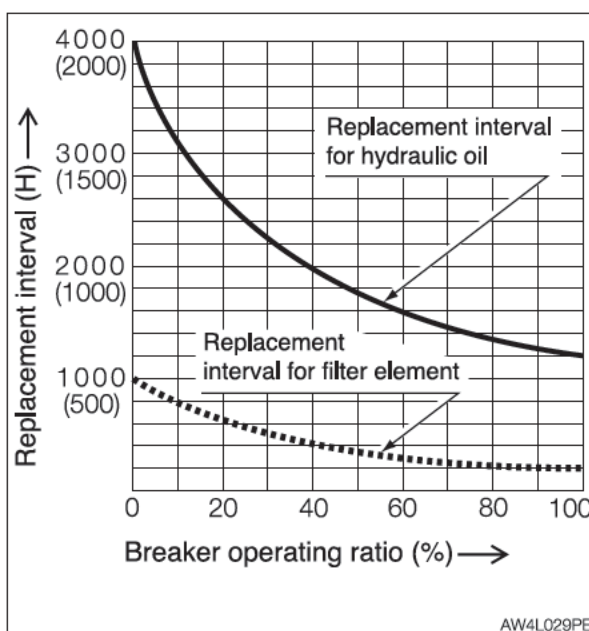

(): When using conventional antiwear hydraulic oil.



TRAVEL ALARM

The alarm sounds while the machine is traveling and stops when the machine stops traveling.

If the alarm does not sound when the machine travels, the fuse may be blown. Inspect the fuses.

WARNING

If the fuse blows again soon after replacement, then the electric system is likely faulty. It may pose a fire hazard if not properly repaired. Contact your sales or service dealer for advice.

1. Turn the starter key to the OFF position to stop the engine.

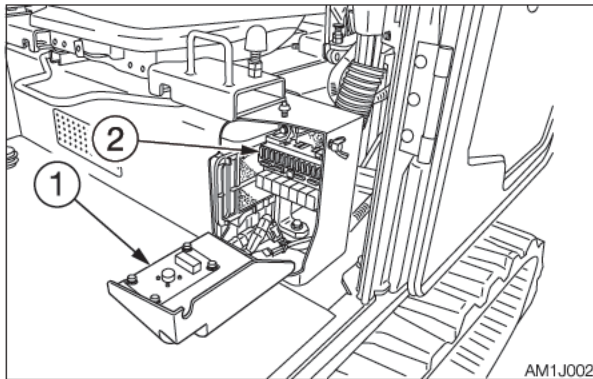

2. Open the fuse box cover (1).
3. Check for any blown fuses (2).

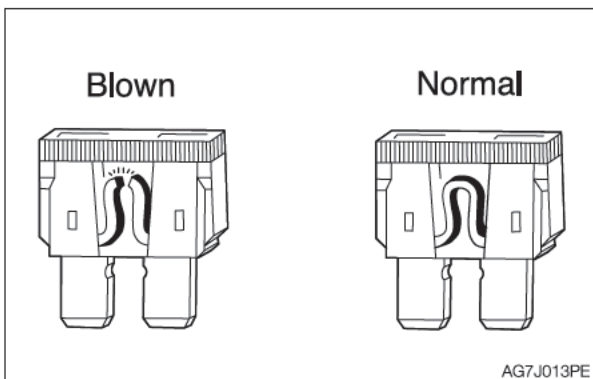

4. If a fuse is blown, replace it with a spare fuse of the same capacity.

Fuse layout and circuits protected

Capacity	Protected circuit	Capacity	Protected circuit
15A	ECM (ACC)	25A	Light
10A	Starter switch (C)	10A	Wiper
5A	Controller (B)	20A	Solenoid
10A	Horn, interior light	10A	Controller (ACC)
		20A	Cigarette lighter, radio, beacon lamp
		10A	Travel alarm, alarm
		25A	Air conditioner blower
		10A	Air conditioner compressor
		5A	Air conditioner controller
		25A	Option (1)
		15A	Option (2)
		25A	Option (3)



OPTIONAL EQUIPMENT MASS

Standard machine mass kg (lb.) Rubber crawlers (Not including operator)	TB285		TB290	
	Rubber crawlers	Steel crawlers	Rubber crawlers	Steel crawlers
	8390 (18495)	8625 (19015)	8440 (18605)	8675 (19125)
OPTION				
Steel crawler, 550-mm width	356 (785)			
Rubber pads	266 (585)			
Shoe guide	18 (40)			
Center guide	21 (46)			
Step	6 (15)			
Wide width blade	7 (15)			
Angle blade	150 (330)			
Lightweight weight	-238 (-525)			
Air suspension seat	19 (40)			
Middle arm	15 (35)			
Long arm	29 (65)			
Long arm (With thumb bracket)	35 (75)			
Arm emergency shut-off valve	4 (10)			
Auxiliary hydraulic lines	Auxiliary 3rd	17 (35)		
	Auxiliary 3rd + Auxiliary 4th.	32 (70)		
Dozer blade with float	5 (10)			
Roof guard (Level 2: ISO 10262)	55 (120)			
Front guard (Level 2: ISO 10262)	60 (130)			

Units: kg (lb)

*: Mass of optional equipment is added to the standard machine mass.

*: This table only contains the optional equipment of 10kg (20lb) or more in mass.



BIODEGRADABLE OIL

Biodegradable oil is a new type of hydraulic oil that is decomposed into carbon dioxide and water by microorganisms in the soil and water. It is highly safe for living organisms and offers advantages in term of environmental protection.

- Recommended biodegradable oil: Mobile EAL EnviroSyn 46H (an ester synthetic oil). When replacing the hydraulic oil with biodegradable oil, use the above or an equivalent oil.
Note that other oils, even other brands of ester synthetic oils, may damage O-rings, packings and seals. Takeuchi products shipped with the optional biodegradable oil are shipped with the above brand of oil.
- When switching from a mineral oil to a biodegradable oil, the parking brake torque decreases by about 30%.

REPLACING THE HYDRAULIC OIL WITH BIODEGRADABLE OIL

Mixing mineral oil with biodegradable oil will result in a decrease of the hydraulic oil's performance as well as a decrease in biodegradability and safety. The hydraulic oil system must be flushed as described below before supplying the biodegradable oil. This operation is dangerous and requires experience. Have it performed by a Takeuchi sales or service outlet.

Flushing

To be performed by a Takeuchi sales or service outlet

1. Drain the hydraulic oil (mineral oil) from the hydraulic tank and clean the inside of the tank and suction strainer.
Refer to "Replacing the hydraulic oil and cleaning the suction strainer".
2. Remove the cylinder hoses and drain the hydraulic oil (mineral oil) from inside the cylinders.
3. Supply new biodegradable oil to the hydraulic tank.

4. Bleed the air from the hydraulic oil system.
5. Operate the hydraulic devices for 30 minutes.
6. Drain the biodegradable oil from the tank and cylinders.
7. Replace the hydraulic oil return filter with a new filter.
8. Repeat steps 3 and 4.
9. Operate the hydraulic devices for 30 minutes.
10. Drain the biodegradable oil from the tank and cylinders.
11. Repeat steps 3 and 4.
12. Operate the hydraulic devices for 1 hour.
13. Drain the biodegradable oil from the tank and cylinders.
14. Replace the return filter with a new filter.
15. Repeat steps 3 and 4.
16. Operate the hydraulic devices, then check for oil leakage.

There is no need to flush the hydraulic oil system when switching from biodegradable to mineral hydraulic oil.



CAB OPTIONS

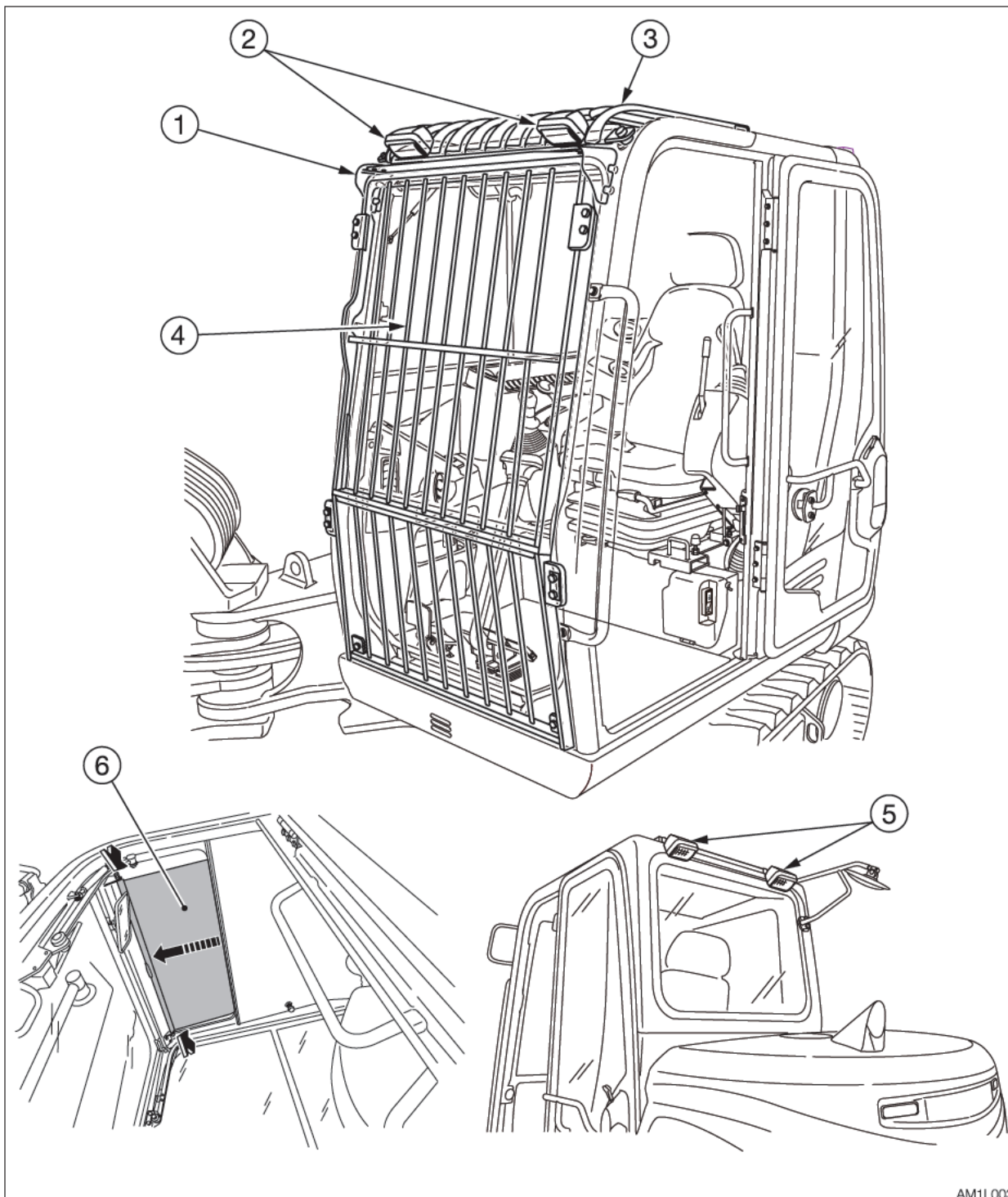

AM1L003

1. Rain guard
2. Front light
3. Roof guard (Level 2: ISO 10262)
4. Front guard (Level 2: ISO 10262)
5. Rear light
6. Sun shade



ANGLE DOZER BLADE

WARNING

- Do not press the float button while the machine is raised by the dozer blade. Doing so will cause the machine to fall. If you must work beneath the raised machine, always use a secure support to keep the machine raised.
- Do not press the float button while the dozer blade is raised. Doing so will cause the dozer blade to fall. Lower the dozer blade to the ground before pressing the float button.
- Do not travel forward while the dozer blade is in the float mode.

IMPORTANT: Do not raise the machine by using the angled dozer blade. Or, the dozer blade may be damaged due to the load concentrated onto a point on the dozer blade.

This dozer blade can be angled (to 25° right or left). Also, it can be used in the float mode.

Angle operation

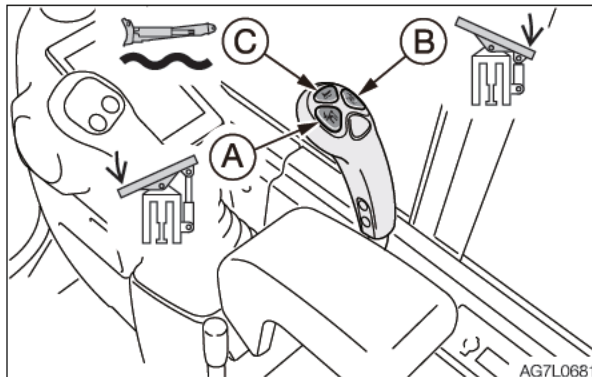
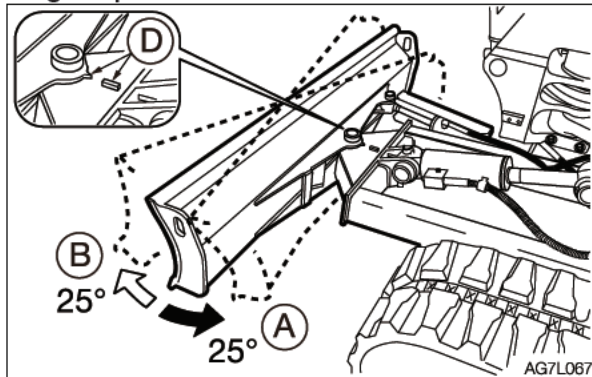

Button (A)Left angle (0 to 25°)

Button (B)Right angle (0 to 25°)

The dozer blade angle is increased/decreased between 0 and 25° as long as the button is pressed.

To position the dozer blade at a right angle, align the matching marks (D) as shown in the figure.

Float operation

Button (C)Float mode

To cancel the float mode, press the button again.

Daily inspection (every 10 hours)

Lubricating

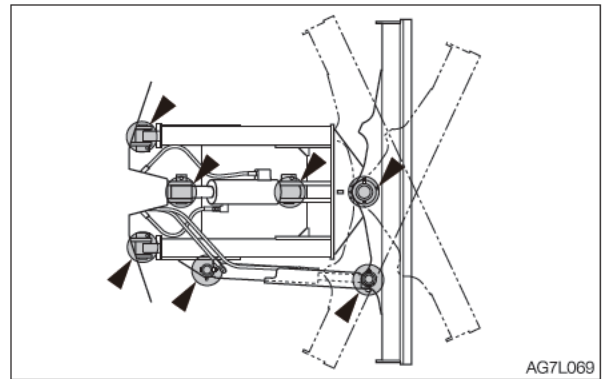

1. Lower the working equipment to the ground and stop the engine.
2. Use the grease gun to lubricate the grease fitting.
3. Wipe off the excess grease.



OPERATING LEVER SWITCH

KIT 1

HORN BUTTON

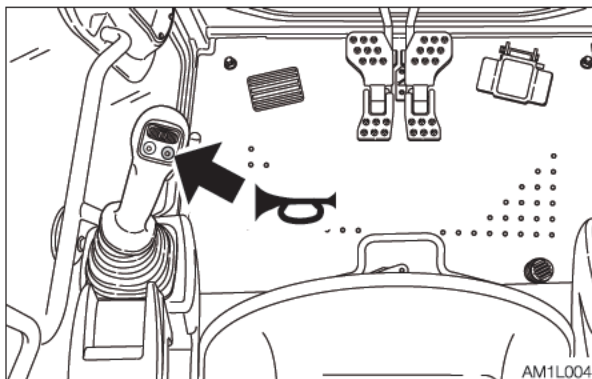

Press the button situated on the left operating lever to blow the horn.

DECELERATION BUTTON

WARNING

Before operating the deceleration button, set the operating lever to the neutral position and take your foot off the pedals. If the deceleration button is pressed while driving, the machine's operating speed will abruptly change to result in a dangerous situation.

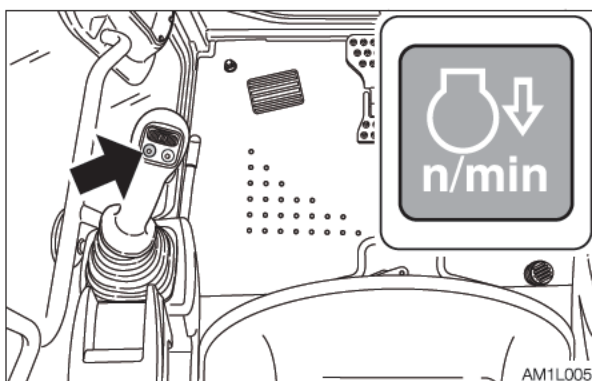

Press this button on the left operating lever to lower the engine speed to low idling. Press the button again to return to the engine speed set with the throttle controller. For safety reasons, it is designed that the deceleration function is activated to set the

engine revolutions to low idling whenever the engine is started.

Cancel the deceleration mode by pressing the deceleration button as necessary.

This deceleration button operation has priority even if the auto-deceleration switch is turned on.

Note: This deceleration button is capable of decreasing the engine speed and reducing the fuel consumption, with a simple operation, in a situation such as when little engine output is required and thus the operating or the travel levers are in neutral.

TRAVEL SPEED BUTTON

WARNING

When a load greater than a set value is applied while traveling in 2nd (high) speed, the speed will automatically slow down to 1st (low) speed. When the load becomes lighter, the speed will increase and return to 2nd (high) speed.

Remember that the travel speed changes depending on the load condition.

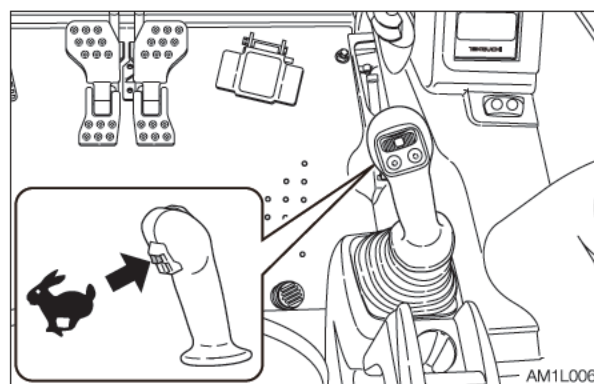

Press this switch to set the travel speed to 2nd (high) speed. Press it again to return to 1st (low) speed.



AUXILIARY 1ST SWITCH

Auxiliary hydraulic buttons

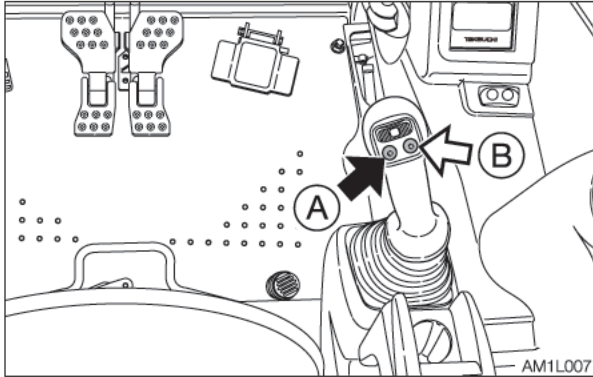

Press those buttons to control the flow of the oil in the first auxiliary hydraulic lines.

- Proportional control of the auxiliary hydraulic circuit is not possible.

- (A).....Hydraulic oil flows to the left auxiliary line (a).
 (B)Hydraulic oil flows to the right auxiliary line (b).

Slider switch

(Proportional control)

Proportional control allows for slow-to-fast/ fast-to-slow movement of attachment.

Example: If you move the slider switch half way, the attachment will move at approximately one-half the speed.

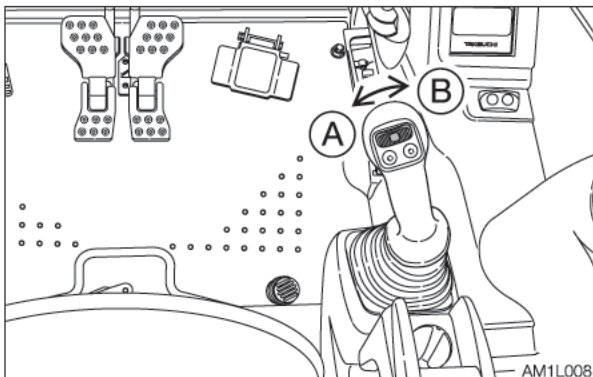

Move this switch to control the flow of the oil in the first auxiliary hydraulic lines.

- (A).....Hydraulic oil flows to the left auxiliary line (a).
 (B)Hydraulic oil flows to the right auxiliary line (b).

Refer to “Auxiliary hydraulic lines” on page 2-46 to 47.

AUXILIARY 2ND/4TH SWITCH

Slider switch

(Proportional control)

Proportional control allows for slow-to-fast/ fast-to-slow movement of attachment.

Example: If you move the slider switch half way, the attachment will move at approximately one-half the speed.

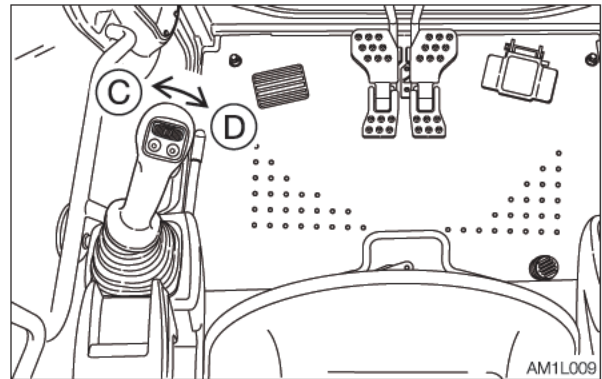

Move this switch to control the flow of the oil in the second auxiliary hydraulic lines.

- (C):Hydraulic oil flows to the left auxiliary line (c).
 (D):Hydraulic oil flows to the right auxiliary line (d).

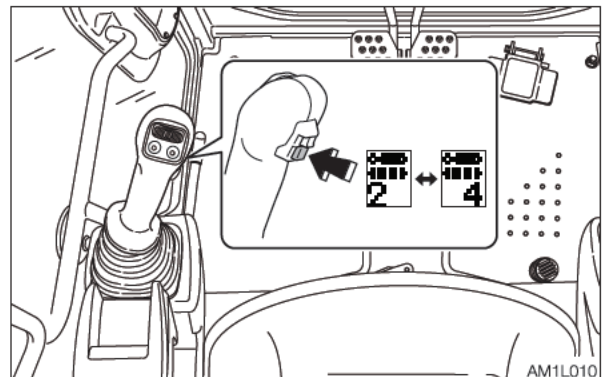

To use the auxiliary 4th hydraulic line, press the auxiliary 2/4 select button to change to the operation of the auxiliary 4th.

Refer to “Auxiliary hydraulic lines” on page 2-46.



AUXILIARY 2/4 SELECT BUTTON

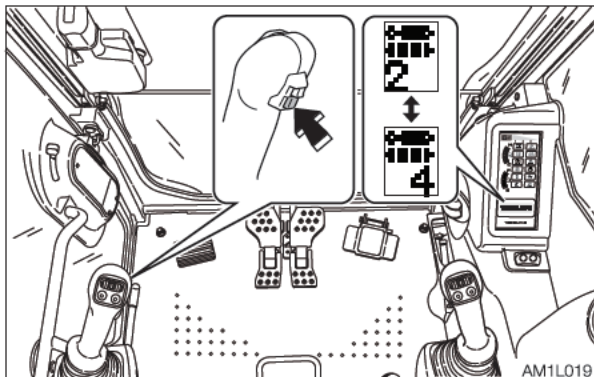

This switch is used to change from the second auxiliary operation to the fourth auxiliary operation. Pressing this button displays the second auxiliary on the LCD to indicate that the second auxiliary operation is enabled. Pressing this button again displays the auxiliary 4th on the LCD to indicate that the auxiliary 4th operation is enabled. The actual operation is performed with the auxiliary 2nd/4th switch (slider switch).

SWING/SECOND BOOM SELECT BUTTON

WARNING

Pressing (switching ON or OFF) the selector button while the boom swing pedal is depressed is dangerous, since the attachment will move unexpectedly. Always set the boom swing pedal back to the neutral position before operating the selector button.

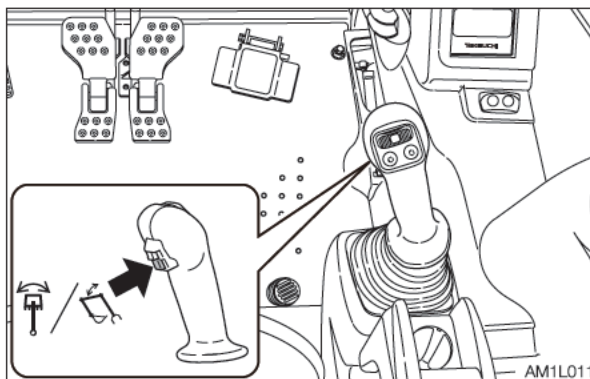

This button changes from the boom swing operation to the second boom operation. Press this button to change over to operation of the second boom. The intermediate second operation indicator lamp will light. One more press of this button will result in a return to boom swing operation. Actual operation is performed with the boom swing pedal.

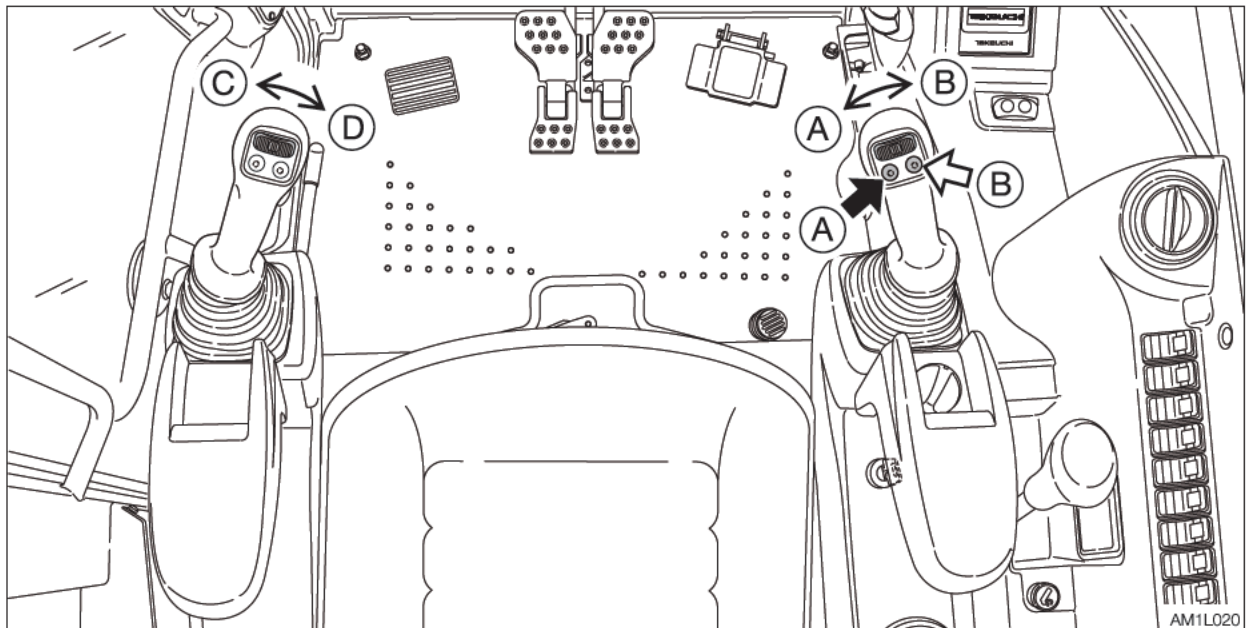

Operating

Press those buttons to control the flow of the oil in the first/second auxiliary hydraulic lines.

- (A).....Hydraulic oil flows to left auxiliary line (a).
- (B)Hydraulic oil flows to right auxiliary line (b).
- (C)Hydraulic oil flows to left auxiliary line (c).
- (D)Hydraulic oil flows to right auxiliary line (d).

Refer to “Auxiliary hydraulic lines” on page 2-46.

Releasing the residual pressure

After the auxiliary hydraulic circuits have been used, pressure remains in the circuits. This is called the residual pressure. Release this residual pressure before disconnecting the lines.

Perform the residual pressure releasing within 30 minutes after the engine stopping.

1. Park the machine on a flat, rigid and safe ground.
2. Stop the engine.
3. Lower the safety lock lever to the unlocked position.
4. Turn the starter switch to the ON position.
5. Press the auxiliary hydraulic switches several times to release the residual pressure in the auxiliary hydraulic circuitry.

First Published March 2011
Sixth Published March 2012

No.33659

OPERATOR'S MANUAL

TB285
TB290 Hydraulic excavator

Edited and issued by TAKEUCHI MFG. CO., LTD.

Printed in Japan by STATION M Co., Ltd.

CALIFORNIA

PROPOSITION 65 WARNING

Diesel engine exhaust and some of its constituents are known to the State of California to cause cancer, birth defects, and other reproductive harm.

Battery posts, terminals and related accessories contain lead and lead compounds, chemicals known to the State of California to cause cancer and birth defects or other reproductive harm. Wash hands after handling battery.

EC-CONFORMITY CERTIFICATE

We herewith declare that following named machine, based on its conception and design and in the form brought into service is in accordance with the relevant, basic safety and health requirements of the following EC directives. In case of any alteration of the machine not coordinated with us, this certificate loses its validity.

Designation of the machine Hydraulic Excavator
Manufacturer TAKEUCHI MFG. CO., LTD
 205 Uwadaira, Sakaki-machi, Hanishina-gun, Nagano
 389-0605, Japan

Model	TB285	TB290
Engine type	4TNV98T-ZXWTB	AU-4JJ1TYSB-03
Engine power	51.6 kW @ 2000 rpm	54 kW @ 2000 rpm

The machine is in accordance with the requirements of EC regulations:

- 1) Machine directive 2006/42/EC and appendix
- 2) Electromagnetic compatibility-regulation 2004/108/EC and appendix
- 3) Noise directive 2000/14/EC (Evaluation procedure according to appendix VI), 2005/88/EC and appendices.
- 4) Regulations on engine emissions: 2004/26/EC and appendices.

Harmonized norms: EN474-1:2006+A1:2009, EN474-5:2006+A1:2009.

Complier of the technical files:

Adam Geiss
Oliver Scharschmidt
Wilhelm Schafer GmbH
68307 Mannheim-Sandhofen GERMANY

Issued in Sakaki, Japan
Akio Takeuchi, President