

5 - 10 Tonne

Thwaites

MACH497, 498, 492, 490,
494, 550, 555, 557, 560, 564,
565, 566, 568, 569

Operator's Instruction Manual

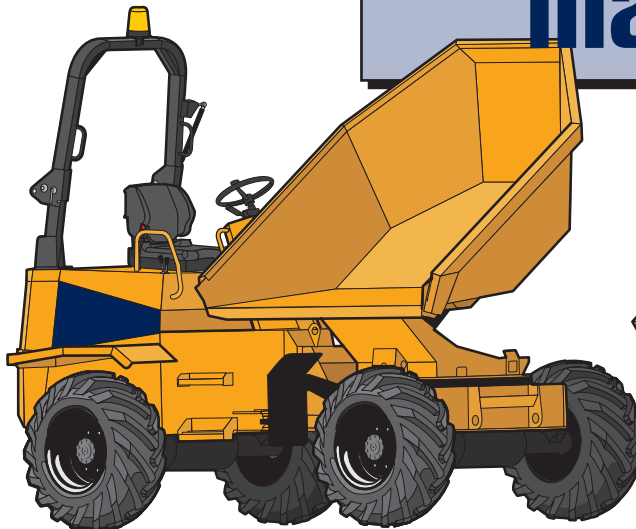

Mach 564 – 6 Tonne Powerswivel

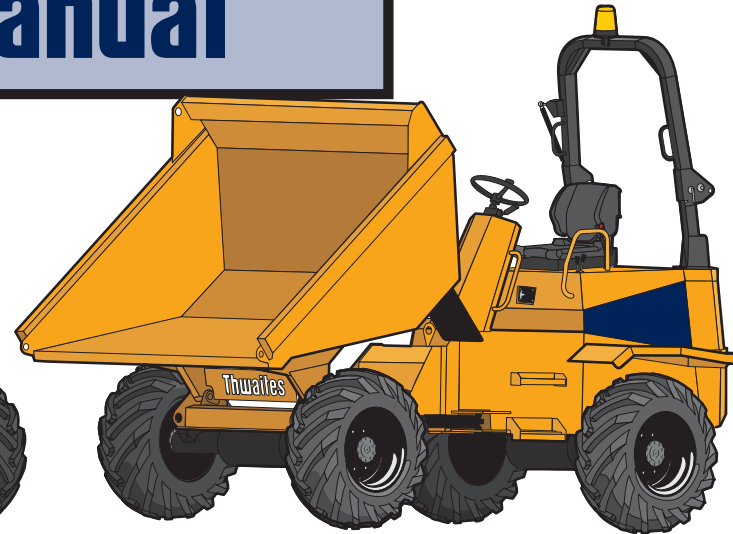

Mach 565 – 6 Tonne Front Tip



Thwaites Limited puts Safety First

It is the policy of Thwaites Limited to promote safety in the operation of its machines and to create a general awareness of site safety and safe working practices for the operators of its machines.

This Operator's Instruction Manual is intended for both new and experienced machine operators. It should remain with the machine at all times. All operators should be aware of its location and contents.

It is important that all operators are fully trained and familiar with the machine and that they have read and understood the information contained within this book before they attempt to operate in the site conditions for which the machine was designed.

This book details practices and operations which Thwaites Limited recommends. DO NOT operate this machine in ways other than those detailed within this book.

This machine is designed for customary construction site operations, and the transportation of bulk materials commonly carried on such sites; that is their 'intended use'. Under certain controlled conditions the dumper may be used for towing

wheeled loads.

Due to the varied nature of the operation of site dumpers and the absence of an agreed test standard, any figures quoted by Thwaites in relation to vibration values and exposure are for reference purposes only. It is the responsibility of the employer to assess vibration exposure based on the actual site conditions, and operating practices, at the point of use.

Hand Arm Vibration - The daily exposure Action/Limit Values of between 2.5 - 5.0m/s² (A8) are unlikely to be exceeded in an eight-hour reference period.

Whole Body Vibration - The daily exposure can only be accurately determined at the point of use. This exposure must be managed in respect of the Action/Limit Values of 0.5 and 1.15 m/s² (A8) respectively.

Employers should not rely solely on published vibration figures when undertaking risk assessments. Depending on the site conditions, cycle times may need to be adjusted in order to reduce operator exposure levels.

Vibration values based on typical duty cycles are available on request from Thwaites. These may be used for reference purposes only.

Safety symbols



- Attention!
- Be alert!
- Your safety is involved!



- Correct action



- Incorrect action/procedure which should NOT be carried out

Signal words

Signal words are used on the machine and within this manual to identify levels of hazard seriousness:

 **DANGER**

 **WARNING**

 **CAUTION**

1 Before operating this machine

Thwaites



Read operator's instruction manual

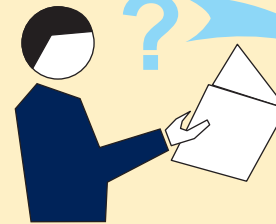
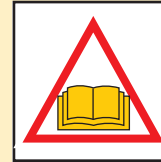

Thwaites
Distributor

1. Contact your Thwaites representative in case of further questions
2. Learn to operate this machine
3. Ensure you are fit to operate
4. Wear correct safety clothing and ensure that safety equipment is available

Complete checks in section



before starting the engine

1 Before operating this machine

Thwaites

Walk around the machine



Visually check the machine

- 1 Are the chassis lock and the skip lock disengaged?
- 2 Are the controls, crush zone or hydraulic rams clean, and clear of any debris?
- 3 Is the Roll-Over Protective frame (ROPS frame) secure, fully upright and undamaged?
- 4 Is the seatbelt anchorage secure and serviceable?
- 5 Are the covers and mudguards secure?
- 6 Are the hoses free from fluid leaks?
- 7 Are all safety decals legible?
- 8 Are the tyres free of cuts or splits?
- 9 Are all bolts tight and in position?
- 10 **Have the daily maintenance tasks been performed? (See rear cover)**

Report all faults immediately.



WARNING

Incorrect tyre pressures reduce machine stability.



DO NOT OPERATE THE MACHINE UNTIL ALL FAULTS HAVE BEEN RECTIFIED

Complete checks in section



before starting the engine

1 Before operating this machine

Thwaites



Mount the machine and check the controls

- 1 Use the grabrails and foot steps provided to manoeuvre into seating position. Face the machine at all times when mounting and dismounting
- 2 Is the engine cover secure and locked?
- 3 Adjust the seat position for comfort and easy access to controls
- 4 Fasten the seatbelt. Adjust accordingly for safety and comfort
- 5 Is the hand brake ON?
- 6 Set the transmission to neutral
- 7 Does the foot brake feel firm?
- 8 Do not operate the machine without understanding all its controls as described in the following pages



 **WARNING**

A seatbelt **MUST BE WORN** when operating machines fitted with a ROPS frame

Complete checks in section



before starting the engine

1 Layout of controls

Thwaites

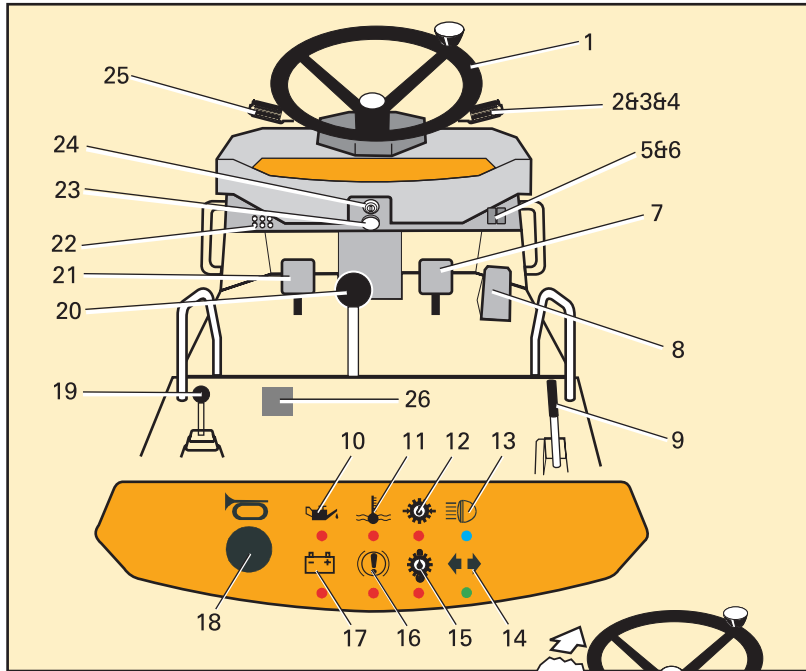

Control locations and functions

- 1 Steering wheel
- 2 Direction indicator selector -
Forward = left turn - back = right turn*
- 3 Lights - twist 1 = sidelights ON -
twist 2 = dipped headlights ON*
- 4 Up = flash. Down = main beam*
- 5 Hazard warning light switch*
- 6 Beacon switch
- 7 Foot brake pedal
- 8 Throttle pedal
- 9 Parking brake lever
- 10 Engine oil pressure warning light
- 11 Water temperature warning light
- 12 Transmission oil pressure warning light
- 13 Headlight main beam pilot light*
- 14 Direction indicator pilot light*
- 15 Transmission oil temperature warning light
- 16 Low brake fluid warning light*
- 17 Battery charging warning light
- 18 Horn push
- 19 Bucket raise/lower/rotate lever
- 20 Gear lever (powershuttle only)
- 21 Dump valve pedal
- 22 Circuit breakers (push to reset)
- 23 Hand brake warning buzzer
- 24 Ignition switch
- 25 Forward/neutral/reverse lever (powershuttle)
Gear/forward/reverse lever (powershift)
- 26 Maxi fuse (under engine cover)

- CB1 Fuel/direction solenoids
- CB2 Instrumentation/warning
- CB3 L/H sidelights*
- CB4 R/H sidelights*
- CB5 Ignition fed lights
- CB6 Battery fed lights

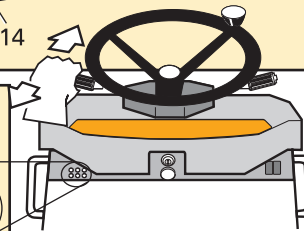
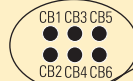

* Optional items

Complete checks in section



before starting the engine

1 Control functions - in depth

Thwaites

Seat adjustment

- A – Turn knob to set driver weight
- B – Lift to slide seat assembly forwards/backwards
- C – Lift handle to adjust backrest

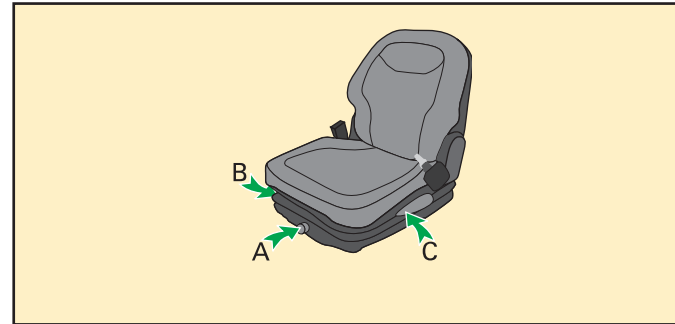

Seatbelt

- Adjust length of belt when seated
- Press buckle blade into buckle lock
- Pull belt webbing through buckle blade to remove slack

 *Seatbelt should not be worn loose. It should pass comfortably across hip bones and not the abdomen*

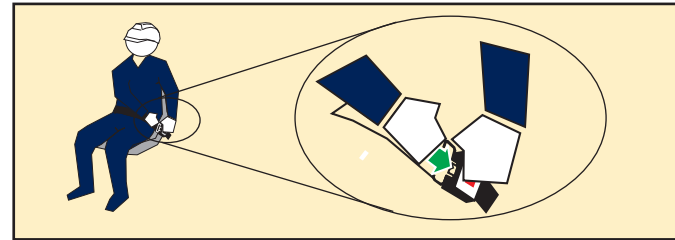

Throttle pedal - right foot

- Apply pressure to increase speed
- Release pressure to reduce speed

Foot brake - right foot

Apply pressure to slow or stop the machine

Dump valve pedal - left foot

Press down before each gear change - select gear, then release

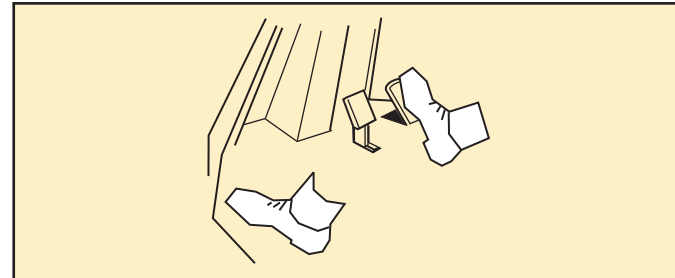

Complete checks in section



before starting the engine

1 Control Functions - in depth

Thwaites

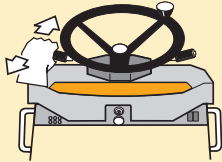

Forward/neutral/reverse lever (FNR lever) (powershuttle) - left hand

- Push forwards to travel in a forward direction
- Lever centred = neutral
- Pull back to travel in a reverse direction

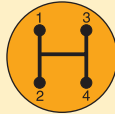
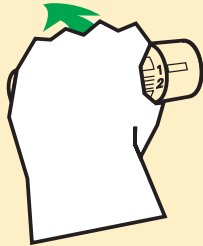
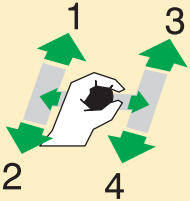

Gear lever (powershift) - left hand

- Up changes - anti-clockwise selects gears 1 to 4
- Down changes - clockwise selects gears 4 to 1

 *Warning - Overspeed time delay sensor fitted*

Gear lever (powershuttle only) - left hand

forward-left
first gear

forward-right
third gear

neutral

back-left
second gear

back-right
fourth gear

Hand brake lever - right hand

- Use only when the machine is stationary (or in an emergency)
- Pull lever up to apply
- Push button and lower lever to release

 *An audible warning device is fitted to your machine. This will sound if the parking brake is engaged whilst forward or reverse is selected.*

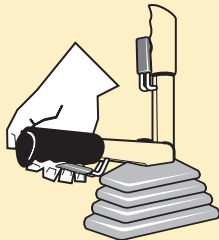

Complete checks in section  before starting the engine

1 Control functions - in depth

Thwaites

Steering wheel - both hands

- Turn the wheel clockwise to turn machine to right
- Turn the wheel anti-clockwise to turn machine to left

 Ensure the non-steering hand is on the engine cover grabrail when using the spinner knob for low-speed single handed steering

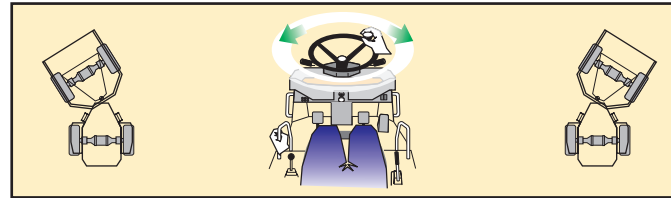

Tippling control lever (front tip models) - left hand

- Push forward to raise skip
- Push backward to lower skip

Tippling control lever (powerswivel models) - left hand

- Raise skip 100 mm (4") to disengage pivot centring lock
- Rotate skip to a central position (fully lowered) to automatically engage centring lock
- Raise skip and push lever to the right to rotate skip clockwise
- Raise skip and push lever to the left to rotate skip anti-clockwise
- Increased engine speed reduces cycle times

 Movement of the bucket is disabled if the steering wheel is moved (steering is given priority)

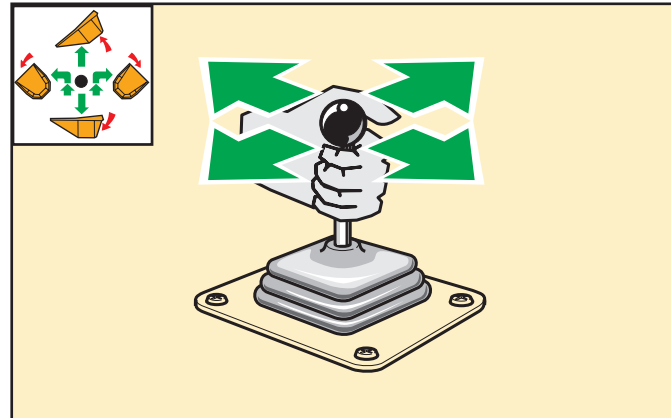

Opening and closing the engine cover

- Insert ignition key and turn anti-clockwise to unlock
- Pull handle to release and raise cover
- Lower cover, secure and lock before driving

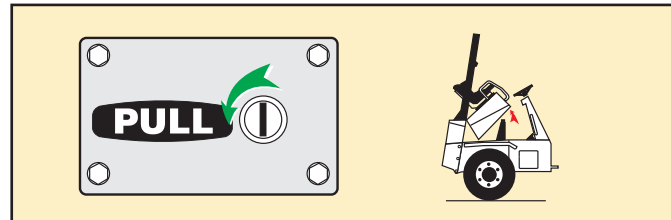

Complete checks in section



before starting the engine

1 Control Functions - in depth

Thwaites

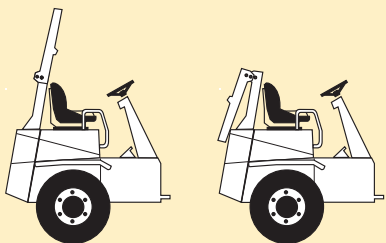

Lowering and raising the ROPS frame

- Remove lynch pins and withdraw frame lock pins
- Lower frame and insert lock pins and lynch pins in new position
- Reverse the procedure to raise the frame
- Ensure all pins are secure before driving

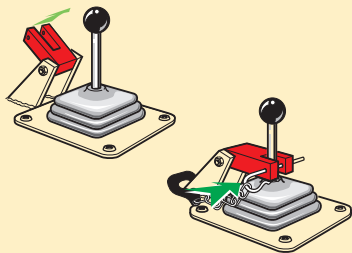

Tipping lever lock (if fitted)

- Place yoke over tipping lever and secure with lynch pin

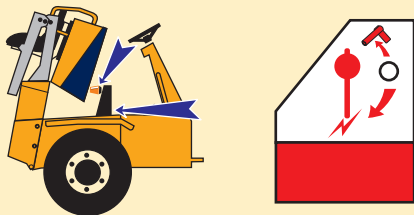

Beacon stowage

- Unplug and remove beacon
- Secure beacon on bracket provided beneath bonnet

Battery isolator (*beneath engine cover*)

- Turn key anti-clockwise to isolate the battery power supply

Complete checks in section



before starting the engine

2 How to START and STOP the engine

Thwaites

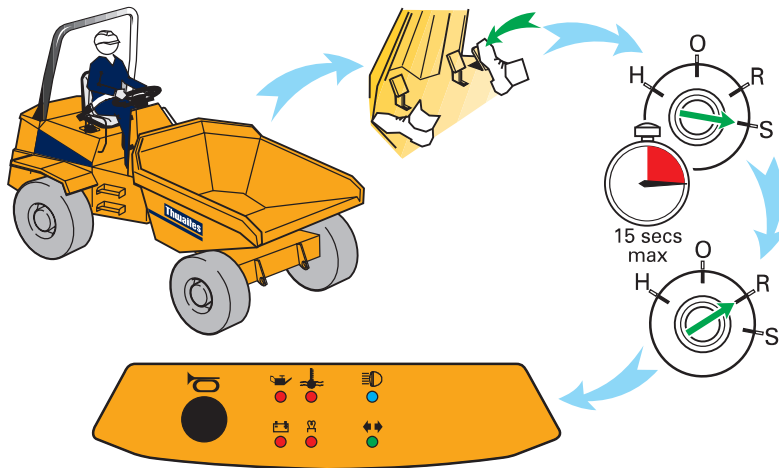

To start the engine

- Depress accelerator pedal fully and turn the key clockwise to the start position 'S'.
All panel lights self-test (illuminate) and should extinguish on start-up.
- Allow the engine to turn for a maximum of 15 seconds
If the engine does not start within 15 seconds return key to 'O' and wait 30 seconds. Turn to 'S' again
- When the engine fires, release key. It will automatically spring to 'R' (run position).
The engine is fitted with an automatic device to ensure ample fuel supply under cold start conditions and economic running.
Position 'H' should only be used below -15°C
- Reduce accelerator pedal pressure to prevent over-revving.

To stop the engine

- Turn key to position 'O'.

! CAUTION

If a panel light remains on switch engine off (turn key to 'O') and investigate the problem.

! CAUTION

- Do not use unauthorised starting aids
- Do not tow or bump start

Complete checks in section  before loading the machine



2 Preliminary checks

Thwaites

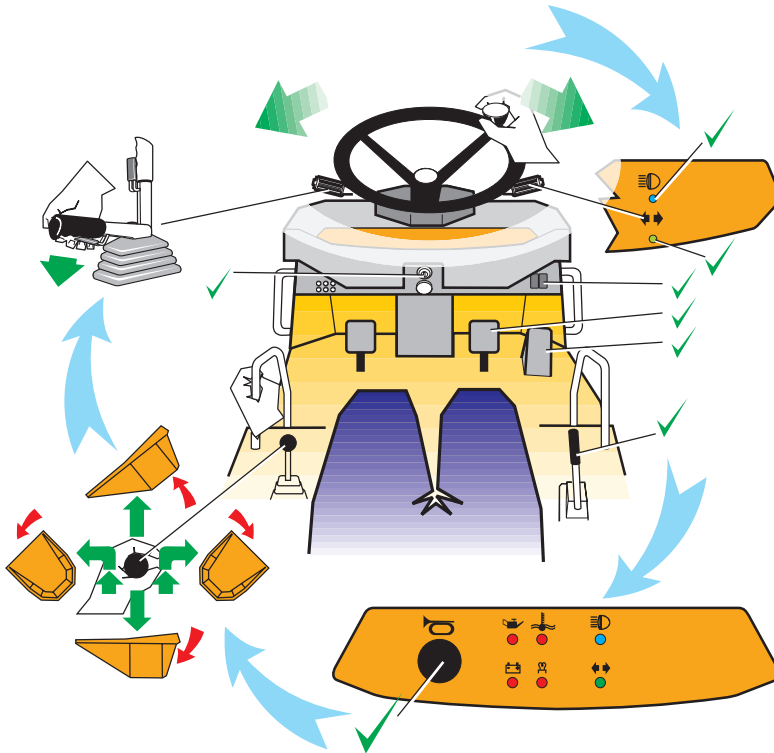

Function checks - engine ON

Brakes

- Does the foot brake feel firm?
- Carry out the hand brake test (*described on next page*)
- If the hand brake is on, and a gear is selected, a buzzer will sound and the drive may be disconnected.

Note: hand brake microswitch must be disconnected to carry out hand brake test (described on next page)

Steering

- Rotate steering wheel clockwise and anti-clockwise

Electrics

- Does the horn sound?
- Does the reverse alarm sound? (optional)
- Does the beacon flash?
- Do all lights work? (optional):
 - side
 - main
 - brake
 - indicators
 - hazard

Tipping lever

- Raise and lower skip
- Rotate skip clockwise and anti-clockwise (*swivel model only*)

Complete checks in section



before loading the machine

2 How to test the hand brake

Thwaites

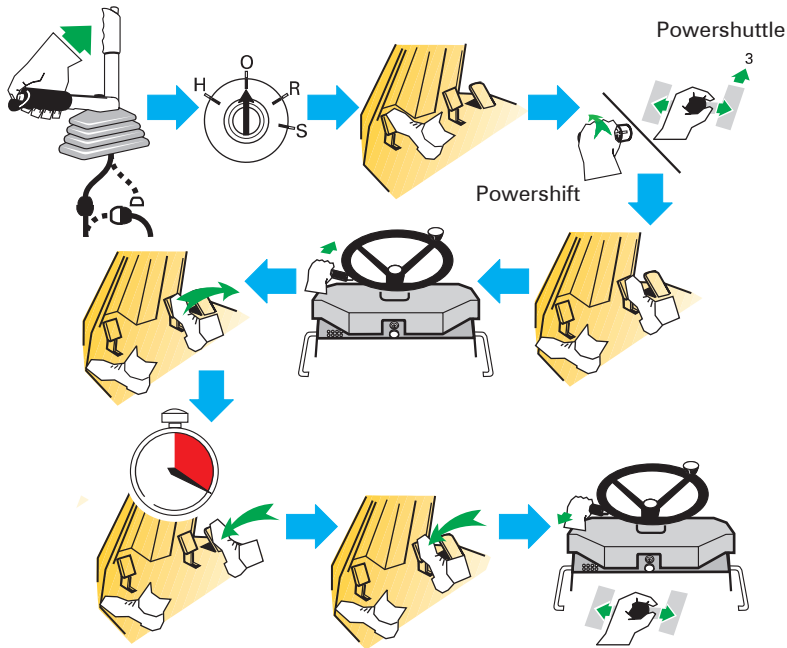

WARNING

Before testing the hand brake ensure the machine is on firm level ground and that there are no people around the machine. Release throttle and apply foot brake if the machine moves during the following test.

- 1 Apply hand brake
- 2 Disconnect microswitch; connect test socket
- 2 Start engine and allow a 1-minute warm-up
- 3 Depress dump valve pedal
- 4 Select third gear (Nat Asp)/fourth gear (turbo)
- Note: Please check the vehicle identification plate (located on the side of the machine) to identify engine power.*
- 5 Release dump valve pedal
- 6 Apply firm pressure on the foot brake pedal
- 7 Select forward drive (the buzzer will sound)
- 8 Slowly reduce brake pedal pressure
- 9 If the machine has not moved, use the throttle pedal to gradually increase the engine speed to full revs (20 seconds max)
- The machine should not move during these tests*
- 10 Reduce engine speed to idle
- 11 Select neutral
- 12 Reconnect microswitch to original position

Note: please refer to the service manual if the machine fails this hand brake test.



WARNING

Do not operate a machine that has moved during the above parking brake test.

Complete checks in section  **2** before loading the machine

2 Driving procedure and safe parking

Thwaites

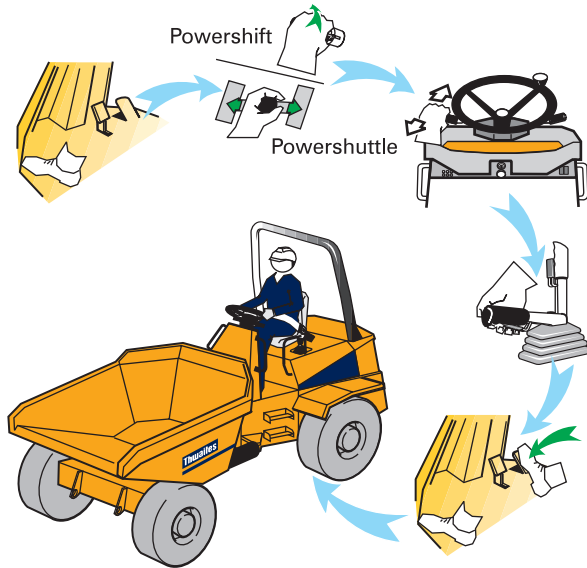

CAUTION

- Novice operators should always start with forward motion on clear, level ground
- A low gear should always be selected when a driver is unfamiliar with machine type

Moving from rest and stopping

- Depress dump valve pedal
- Select first gear
- Release dump valve pedal
- Select forward or reverse
- Release hand brake fully (machine may move)
- Slowly depress accelerator and move away
- Hold steering wheel with both hands
- Remove foot from accelerator pedal
- Brake gently to a halt using foot brake

Changing speed/direction

- Depress dump valve pedal
- Select next gear
- Release dump valve pedal
- The machine must be stationary and the hand brake must be engaged before changing direction

After operating - park safely

- Always leave skip empty when not in use
- Ensure machine is on firm level ground
- Apply hand brake
- Engage transmission to neutral
- Fully lower skip, in a central position
- Set drive to neutral
- Stop engine and remove key
- Ensure machine cannot be started

Complete checks in section

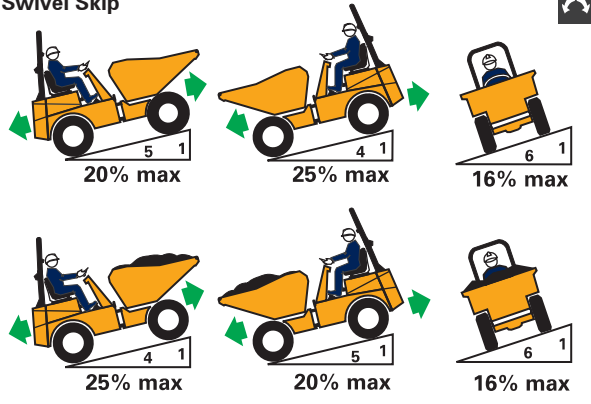
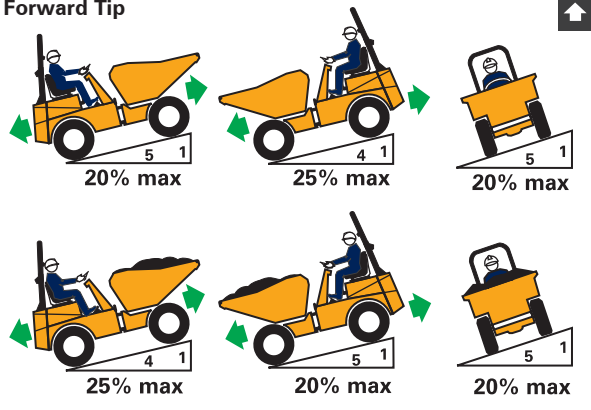

before loading the machine

3**DANGER****IMMEDIATE HAZARDS WHICH WILL RESULT IN SEVERE PERSONAL INJURY OR DEATH****Thwaites****Swivel Skip****Forward Tip****WORKING ON GRADIENTS**

DO NOT exceed maximum stated gradients



DO NOT turn across gradients



DO NOT brake suddenly in wet, muddy, icy conditions or when operating on loose surfaces



DO NOT run downhill with controls in neutral



Travel straight up, down or along a gradient



Keep speed to a minimum and use the foot brake to reduce speed when travelling down gradients



Always engage hand brake when stopped on sloping ground to prevent movement, and in addition, chock wheels securely when leaving the machine unattended



Always position swivel skip in central lock

Attention! Section **3** correct and incorrect working practices

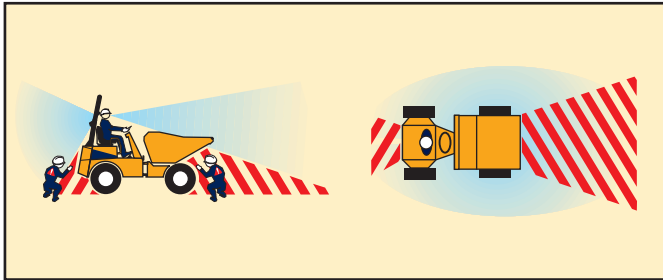
3 **DANGER****IMMEDIATE HAZARDS WHICH WILL RESULT IN SEVERE PERSONAL INJURY OR DEATH****Thwaites****VISIBILITY**

Check ahead and behind machine before operation



Be aware of low-visibility areas when operating



Before operating, sound the horn to warn people in the immediate area

**CRUSH ZONE**

Stay clear of articulation area when the engine is running

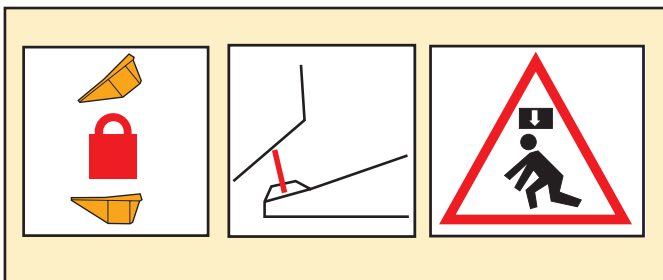

Never operate the machine's controls when standing on either side of machine

**WORKING UNDER A RAISED SKIP**

Lock both skip safety props during maintenance









Never work under an unpropped skip

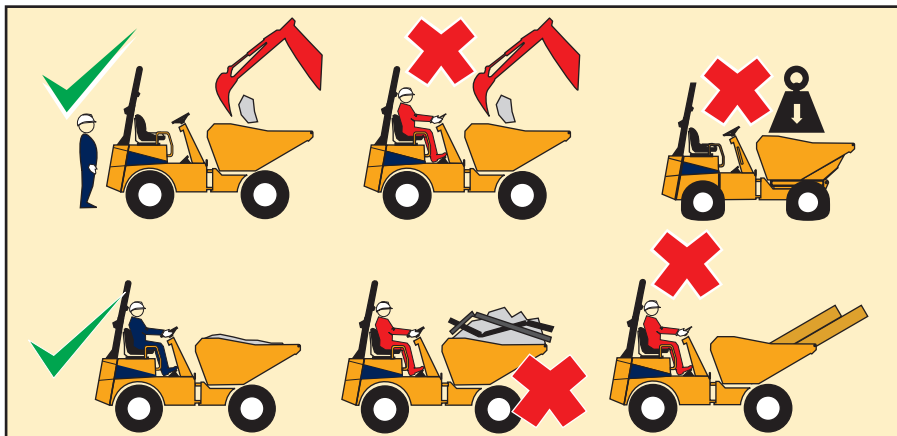





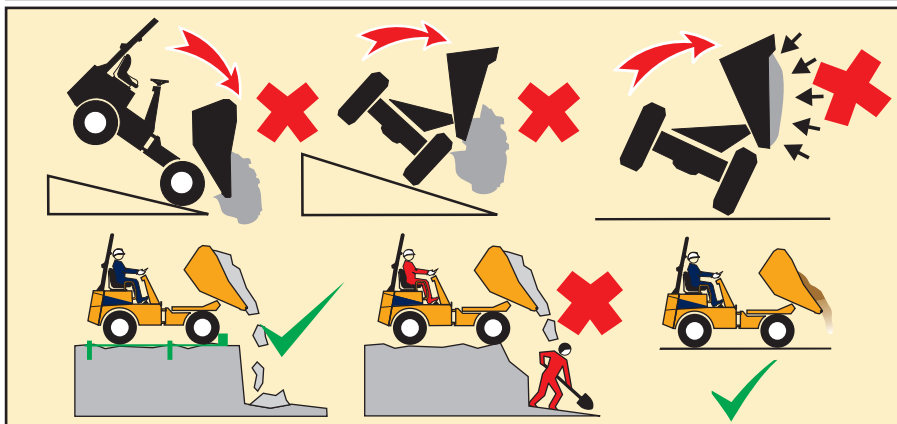

When using skip safety prop engage tipping lever lock (If fitted)

*Attention! Section***3***correct and incorrect working practices*

3 **WARNING****HAZARDS OR UNSAFE PRACTICES WHICH COULD RESULT IN SEVERE PERSONAL INJURY OR DEATH****Thwaites****LOADING THE MACHINE**

-  Apply hand brake, set transmission to **NEUTRAL**, turn engine **OFF**, disembark the machine and **STAND CLEAR**
-  **DO NOT** exceed the machine's rated capacity
-  Clear debris from controls and footplate
-  Ensure **SAFE STABLE LOW** load which allows good visibility
-  Materials carried must be free-flowing

**UNLOADING THE MACHINE**

-  **DO NOT** discharge load when working on sloping ground
-  **DO NOT** discharge load to the side of the machine if material carried is not free-flowing
-  Discharge load forwards if material carried is not free-flowing
-  Discharge load on level ground
-  Use **STOPBOARDS** and **SUPPORT** walls on trenches

Attention! section  correct and incorrect working practices

3

WARNING

HAZARDS OR UNSAFE PRACTICES WHICH COULD RESULT IN SEVERE PERSONAL INJURY OR DEATH

Thwaites

DRIVING

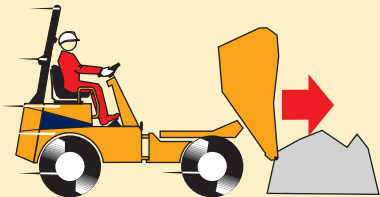

DO NOT drive with the bucket tipped (bulldozing)

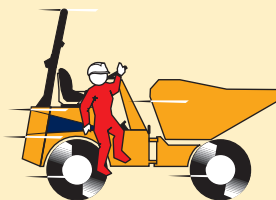

NEVER dismount from a moving machine



DO NOT carry passengers



Avoid confined work areas - exhaust fumes and noise can be a hazard



Site hazards to avoid: adverse weather conditions, icy surfaces, people

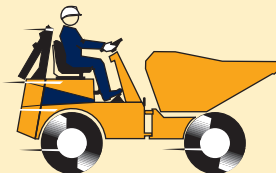

DO NOT operate with the ROPS frame folded down

Attention! Section

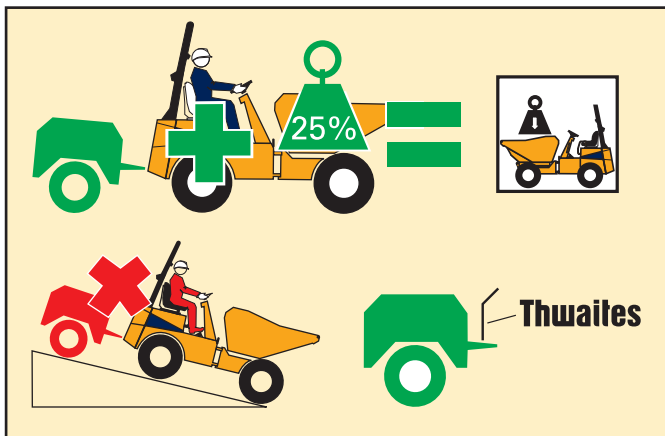

correct and incorrect working practices

3 **WARNING****HAZARDS OR UNSAFE PRACTICES WHICH COULD RESULT IN SEVERE PERSONAL INJURY OR DEATH****Thwaites****TOWING A TRAILER**

Place ballast load in skip. This load should be a minimum of 25% of the machine's rated payload



The gross weight to be towed plus the ballast load **MUST NOT** exceed rated payload of machine



DO NOT exceed maximum tow bar pull or vertical load



Towing must not be carried out on sloping ground

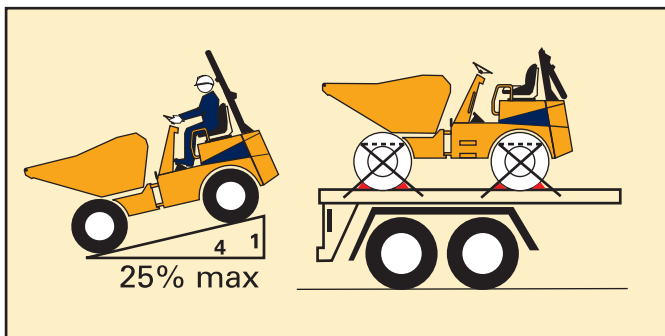

Always use a Thwaites-approved towing pin

**TRANSPORTATION**

Reverse machine slowly onto a suitable trailer



DO NOT drive the machine forward when loading



Apply hand brake

Stop engine

Chock wheels (*To prevent movement*)



Engage chassis locking bar

Secure to trailer

Ensure legal load (*Height/weight of trailer*)



Attention! section **3** correct and incorrect working practices

3**CAUTION**HAZARDS OR UNSAFE PRACTICES WHICH **COULD** RESULT IN MINOR PERSONAL INJURY OR PRODUCT OR PROPERTY DAMAGE**Thwaites****USING A CRANE TO LIFT THE MACHINE**

- Tip skip fully forward (except 9 and 10 Tonne)
- Engage skip safety prop
- Engage chassis locking bar
- Lift using centre eye provided

**HAND BRAKE**

- DO NOT** apply hand brake if machine is moving (except in an emergency)

**SLOPING SURFACES**

- DO NOT** step on the rear mudguards' sloping surfaces. Use tread grip area (if fitted) to raise or lower hinged ROPS.

**HINGED ROPS**







- Use grab handles, tread grips (if fitted) and steps when standing on the machine to lower the ROPS frame.



- Avoid wet surfaces.

Attention! Section*correct and incorrect working practices*

4 Troubleshooting

Problem	Reason	Solution
Engine will not start	isolator switch is turned off FNR lever not in neutral battery voltage too low faulty fuel supply electrical stop on fuel pump defective circuit breaker tripped	switch isolator switch on shift transmission to neutral check battery and connections check fuel level and connections check connections reset (push to reset)
Complete loss of electrical functions	maxi fuse blown	rectify electrical fault and replace fuse
Starter motor will not operate	faulty battery	replace
Maxi fuse blown	faulty starter motor/solenoid (current drawn by solenoid exceeds 25A) short circuit on main feed or starter solenoid cables	replace starter motor/solenoid and maxi fuse (only replace with a 30 amp fuse) locate and repair
Engine stops soon after start-up	blocked fuel or air filter air in fuel system	replace fuel or air filter check fuel line connections
Black engine smoke	air filter clogged (Indicator red) fuel system defect wrong fuel	replace or clean air filter contact Thwaites dealer replace fuel and filter
Machine will not move when FNR lever is selected	hand brake applied – machine fitted with isolator	release hand brake lever
 ● Engine oil pressure  ● High engine temperature  ● Low coolant level  ● Irregular alternator  ● Transmission oil temperature  ● Transmission oil pressure  ● Low brake oil Warning buzzer sounds	low oil level radiator choked top up coolant defective or loose alternator belt oil cooler choked over/under filled with oil low transmission fluid level check oil level/leaks hand Brake ON	top up engine oil clean radiator adjust, or, if necessary, replace alternator belt clean oil cooler correct oil level top up transmission fluid top up brake oil release hand brake

Always check panel warning lights, tripped circuit breakers or blown maxi fuse

4 Data Chart – Powerswivel

Thwaites

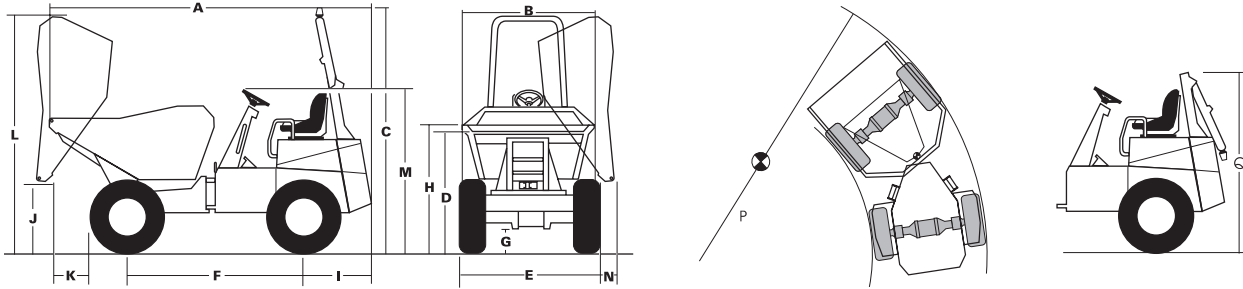

Dimensions (mm)	5T	6T	9T	Weight (kg)	5T	6T	9T	Noise
A. Length	4780	4780	5011	Unladen				Airborne (10 m)
B. Width	2135	2280	2435	Front axle	1680	1780	2130	
C. Height (ROPS frame & Beacon)	3320	3300	3415	Rear axle	2420	2490	3150	
D. Bucket lip height	1615	1670	1820	Total	4100	4270	5280	Turbo
E. Width over tyres	2100	2240	2440	Laden (including driver at 80 kg)				
F. Wheelbase	2480	2480	2660	Rated payload	5000	6000	9000	
G. Ground clearance	320	370	447	Front axle	6240	7420	10030	Operator
H. Bucket load height	1795	1850	2002	Rear axle	2940	2930	4330	
I. Axle to rear	1200	1200	1220	Total	9180	10350	14360	
J. Tipping ground clearance	1050	1100	1134	Towbar (Max)				
K. Tipping tyre clearance	540	550	1131	Pull load	3750	4500	6750	
L. Height tipped (skip)	3650	3694	4000	Vertical load	500	500	500	
M. Max height without ROPS frame	2190	2230	2630	Tyre Pressure				
N. Tipping side clearance	140	100	378	Bar (psi) front	4.9(71)	3.9(57)	3.4(49)	
P. Tyre clearance diameter (m)	12.0	12.0	13.4	rear	2.5(36)	2.5(36)	1.6(24)	
Q. Height (ROPS frame folded)	2170	2230	2630					

Hyd mainline pressure - 170 bar

4 Data Chart – Front tip

Thwaites

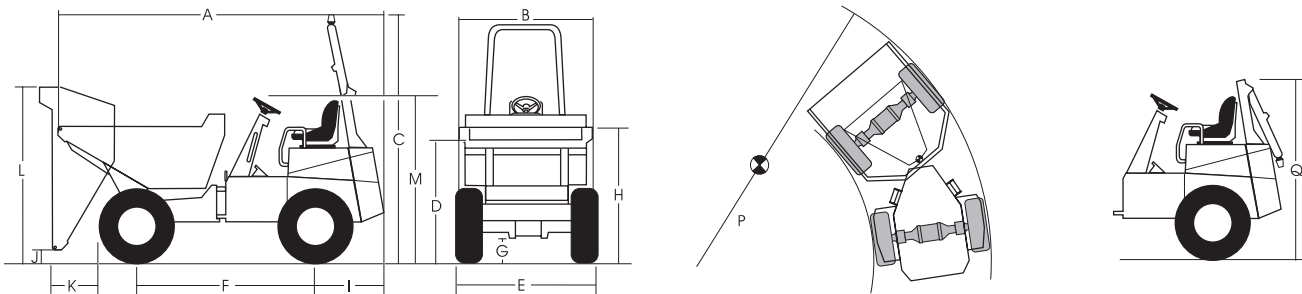

Dimensions (mm)	5T	6T	7T	9T	10T	Weight (kg)	5T	6T	7T	9T	10T	Noise
A. Length	4438	4440	4450	4635	4650	Unladen						Airborne (10 m) Turbo After-cooled Operator
B. Width	2165	2354	2354	2485	2485	Front axle	1390	1490	1530	1740	1760	
C. Height (ROPS frame & beacon)	3320	3390	3390	3335	3415	Rear axle	2480	2590	2590	2860	2920	
D. Bucket lip height	1600	1610	1610	1740	1740	Total	3870	4080	4120	4600	4680	
E. Width over tyres	2100	2240	2240	2440	2440	Laden (including driver at 80 kg)						
F. Wheelbase	2480	2480	2480	2615	2615	Rated payload	5000	6000	7000	9000	10000	
G. Ground clearance	330	370	370	447	447	Front axle	5525	6525	7455	8740	9600	
H. Bucket load height	1700	1740	1780	1975	2135	Rear axle	3425	3635	3745	4940	5160	
I. Axle to rear	1200	1200	1200	1220	1220	Total	8950	10160	11200	13680	14760	
J. Tipping ground clearance	310	340	340	436	436	Towbar (Max)						
K. Tipping tyre clearance	574	520	520	642	768	Pull load	3750	4500	5250	6750	7500	
L. Height tipped (skip)	2479	2505	2505	2840	2860	Vertical load	500	500	500	500	500	
M. Max height without ROPS frame	2190	2230	2230	2440	2540	Tyre pressure						
P. Tyre clearance diameter (m)	12.4	12.6	12.6	13.5	14.0	Bar (psi) front	4.0(58)	3.5(51)	3.9(57)	3.2(46)	3.2(46)	
Q. Height (ROPS frame folded)	2190	2230	2230	2555	2630	rear	2.5(36)	2.7(39)	3.0(44)	1.6(24)	1.6(24)	

Hyd mainline pressure - 170 bar

4 Daily/Weekly Checks

Thwaites

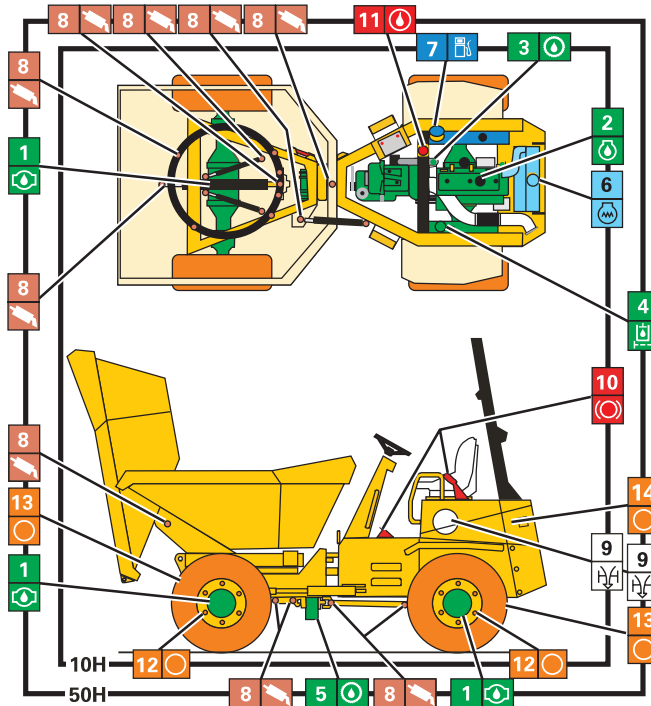

	AXLE OIL (Centre case + Hubs)	1	TRACTELF SF3
	ENGINE OIL	2	BP Vanellus C5 Global 15W 40
	TRANSMISSION OIL	3	Autran MBX
	HYDRAULIC OIL	4	Energol HLP HM32
	DROPOX OIL	5	Energear Hypoid Gear + Transmission 80W-9
	COOLANT LEVEL	6	H ₂ O + 33% anti-freeze
	FUEL LEVEL	7	Diesel
	GREASE	8	Fill all points
	AIR CLEANER	9	Check indicator
	BRAKES	10	Test hand brake & foot brake
	BRAKE OIL	11	BP Bartran HV32
	WHEEL NUTS	12	330 Nm
	TYRE PRESSURE	13	See data chart
	FAN BELT	14	Check condition/tension

This machine must be serviced after first 100 hours

Normal service intervals: 250 hours 500 hours 1000 hours 2000 hours

Contact local Thwaites Distributor for details or www.thwaitesdumpers.co.uk

Note: failure to use Thwaites-approved lubricants may invalidate your warranty

Please refer to the service manual for maintenance information