

Kubota

MINI EXCAVATOR

GB

MODELS

KX057-4

U48-4

U55-4



OPERATING INSTRUCTIONS

Dear valued customer,

please fill in the form below. Your information will help us to help you.

<p>Type:</p> <p>Year of construction:</p> <p>Serial #:</p> <p>Shipment date:</p>
--

Please contact your KUBOTA dealer for any additional information or troubleshooting procedures not mentioned in these operating instructions.

We also point out that the contents of these operating instructions are not part of an earlier existing agreement, promise or legal relationship or amend this. All responsibilities arise of the respective sales contract containing the complete and exclusively valid contractual warranty, refer to the "Duties, liability and warranty" section (page 14). This documentation does neither extend nor restrict the contractual warranty.

KUBOTA Baumaschinen GmbH reserves the right to change the information contained in this document with respect to future technical development without altering the basic characteristics of the excavators described herein and without amending this document.

Distribution and reproduction of this documentation and disclosure of its content are not allowed unless expressly approved by the manufacturer. Violators of the above terms are liable for compensation for damages.

Table of contents

Abbreviations.....	8
General symbols	9
General information	11
Foreword	11
EC declaration of conformity	11
Date of issue of the operating instructions	12
Operating personnel.....	12
Location of the operating instructions.....	12
Spare parts.....	13
Safety rules	14
Basic safety instructions.....	14
Duties, liability and warranty.....	14
Safety symbols.....	15
Approved use	16
Unapproved use	16
Special duties of the owner	17
Noise emission and vibration	17
Noise emission	17
Vibrations	17
Safety labels on the excavator	18
Safety devices.....	26
Locking the controls	26
Engine stop knob	26
Canopy (FOPS) and roll-over protection (ROPS)	27
Emergency hammer.....	27
Pipe safety valve	27
Overload warning function	28
Hazards coming from the hydraulic system	28
Fire protection	29
Recovery, loading and transport	30
Safety rules for recovery	30
Safety rules while loading with a crane	30
Safety rules for transport.....	31
Recovery	32
Hoisting the excavator with a crane	32
Transport on a flat bed trailer	34
Description of the excavator	36
Model overview	36
Model KX057-4, U48-4 and U55-4.....	36
Dimensions.....	37
Dimensions KX057-4, U48-4 and U55-4.....	37
Specifications	39
Specifications KX057-4	39
Specifications U48-4	40
Specifications U55-4	41
Identification of the excavator.....	42
Serial # of the machine	42
Engine number	43
Equipment	43
Standard equipment.....	43

Assembly and functions	44
Component overview	44
Operator's place	45
Left control console	45
Description of the components of the left control console	45
Drive levers and control pedals	46
Drive levers and control pedals – description	46
Right control console	47
Description of the components of the right control console	47
Display and control unit - description	49
Other equipment to be found at the machine	50
Wiper/washer system.....	50
Interior lighting	50
Fuse box	50
Tool compartment (KX057-4).....	51
Tool compartment (U48-4 and U55-4)	51
Main battery.....	51
Battery cut-off switch	52
Cup holder	52
Tank filler neck and fill level monitor.....	52
Tank filler neck and fill level monitor with suction pump (optional only KX057-4).....	53
Rear view mirror	53
Heating and air-conditioning system (optional)	53
Engine compartment	55
Hydraulic system	56
Radiator and condenser	56
 Operation	 57
Safety rules for operation	57
Guiding the operator.....	58
Working in the vicinity of overhead power lines.....	58
Working in the vicinity of underground power lines	58
Initial operation	59
Setting the display language	59
Setting the time.....	60
Date and time display format.....	61
Running-in of the excavator.....	62
Special maintenance instructions	62
Operating the excavator	62
Pre-operational services.....	62
Checking the engine oil level	62
Checking the coolant level.....	63
Checking the radiators and the condenser	63
Checking the V-belts.....	64
Checking the exhaust system for leaks	64
Checking the oil level of the hydraulic system	65
Greasing the bucket bolts and bucket linkage bolts.....	65
Checking the electric cables and connections	66
Checking fuel level, coolant temperature and time	66
Setting up the workplace	66
Getting on the excavator.....	66
Adjusting the operator's seat	67
Horizontal seat adjustment (seat stand-off).....	67
Seat height adjustment (knee height).....	67
Spring adjustment (operator's weight).....	67
Backrest adjustment.....	67
Seat belt	68
Rear view mirrors adjustment	68
Safety instructions for starting the engine	68

Starting the engine	69
Stopping the engine	70
Observation of the displays after starting and during operation	71
Driving the excavator	73
Driving.....	74
Turning	75
During driving	75
From a standing position.....	76
Turning on the spot	76
Driving uphill and downhill	77
Notes for rubber crawler operation	77
Making sharp turns.....	78
Protecting the crawler against salt	78
Operating the controls during excavation work	78
Note on using wider and deeper buckets	79
Operating the dozer	79
Overview of control lever functions (standard setting).....	80
Operating the boom.....	80
Operating the arm.....	81
Operating the bucket	82
Swivelling the swivel frame.....	83
Swinging the boom	83
Operating the auxiliary ports	84
Activating the auxiliary port function.....	84
Auxiliary port 1	85
Auxiliary port 2	85
One way hold operation	86
Operating modes.....	86
Flow rate setting.....	88
Return change valve for direct return flow.....	92
Pressure relief of the hydraulic system.....	93
Pressure relief of the auxiliary ports	93
Placing out of operation.....	95
Operating the heating and air-conditioner system (optional).....	96
Heating the cab	96
Cooling the cab	96
De-icing or demisting the windows.....	97
Operating the wiper/washer system	97
Switching on the windscreen wiper	97
To turn on the washer system.....	98
Operating the room light.....	98
Operating the rotary beacon.....	98
Operating the 12 V plug	99
Opening and closing the cab door.....	99
Opening the cab door from outside	99
Closing the cab door	99
Opening the cab door from the inside	100
Opening and closing the windows.....	100
Front window	100
Side window	101
Operating the working light (boom)	101
Operating the working lights (cab).....	101
Cold weather operation	102
Necessary preparations prior to the winter season	102
Operation during the winter season	102
Jump-starting the excavator	103
Emergency stop functions.....	104
Engine stop knob	104
Manual lowering of the front attachments	104





































Filling up the washer system	105
Refuelling the excavator	105
Refuelling the excavator equipped with optional suction pump (only KX057-4)	106
Refuelling the excavator using the optional suction pump (optional only KX057-4)	106
Fill level monitor when refuelling	107
Bleeding the fuel system	108
Replacing the fuses	108
Fuse layout of the fuse box	109
Main fuses	110
Operating the battery cut-off switch	110
Opening and closing the engine compartment cover	110
Opening/closing the side cover	111
Opening/closing the tool compartment (KX057-4 only)	112
Opening/closing the service covers	112
Opening/closing the front service covers	112
Opening/closing the left service cover (optional KX057-4 only)	112
Replacing the bucket	113
Anti-theft system	113
Black (individual) key	113
Red key (for registering)	114
The key system	114
Registering a black key for the machine	115
Troubleshooting	117
Safety rules for troubleshooting	117
Troubleshooting: Before operation	117
Troubleshooting: Operation	118
Troubleshooting: Display indications	119
Maintenance	124
Safety rules for maintenance	124
Personnel requirements	124
General maintenance chart: 50 to 500 hours of operation	125
General maintenance chart: 550 to 1000 hours of operation	126
Servicing maintenance chart: 50 to 500 hours of operation	127
Servicing maintenance chart: 550 to 1000 hours of operation	128
Cleaning the excavator	129
Servicing	129
Refilling coolant	129
Cleaning the radiators and the condenser	130
Checking, adjusting and replacing the V-belts	131
Checking the coolant hoses	131
Replacing the coolant	132
Replacing the engine oil and oil filter	133
Draining the engine oil	133
Replacing the oil filter	133
Filling the engine oil	134
Checking, cleaning and replacing the air filter	135
Replacing the fuel filter	136
Checking and emptying the water separator	136
Cleaning the water separator	137
Draining the fuel tank	137
Checking the fuel lines and the air intake hoses	138
Replacing the return filter in the hydraulic oil tank	138
Replacing the tank breather filter	139
Replacing the pilot circuit filter	140
Replacing the suction filter in the hydraulic oil tank	141
Topping up/changing the hydraulic oil	142
Draining the hydraulic oil	142



























Filling the hydraulic oil	143
Battery service	144
Checking the battery	144
Charging the battery	144
Installing/uninstalling and replacing the battery	145
Lubrication	146
Greasing the swivel gear	146
Greasing the pitch bearing	146
Greasing the swing bracket	147
Other greasing points	147
Checking and tensioning the crawler tension	148
Checking the crawler tension	148
Checking the crawler tension (steel)	149
Adjusting the crawler tension	149
Replace the drive unit oil	150
Checking, cleaning, replacing the interior air filter	150
Checking the pipes and hoses of the heating and air-conditioner systems	151
Checking the coolant content (air-conditioner only)	152
Viewing the operations log	153
Checking the bolted joints	154
Tightening torque for screws	154
Tightening torque for hose clamps	154
Tightening torque for hydraulic hoses	155
Tightening torque for hydraulic pipes	155
Tightening torque for hydraulic adapters	156
Tightening torque for elbow pipe joints with shim	156
Recommended lubricants	157
Excavator repairs	158
Safety inspection	159
Taking out of service and storage	160
Safety rules for taking out of service and storage	160
Storage conditions	160
Measures before taking out of service	160
Measures during taking out of service	160
Start-up after taking out of service	161
Lifting capacity of the excavator	162
Constructive calculation of lifting capacity	162
Lifting attachment	162
Load suspension device	163
Max. lifting load during swivel operation is 360°	164
Accessories	172
KUBOTA Rotary beacon	172
KUBOTA Pipe safety valve	172
Note on use	173
KUBOTA Quick coupling systems and equipments	173
KUBOTA Bucket accessories	173
Replacing the bucket	173
Remove the bucket	174
Install the bucket	175

Abbreviations

%	percent	kg	kilogramme
°	degrees	km/h	kilometre per hour
°C	degree Celsius	kN	kilonewton
1/min	revolutions per minute	kV	kilovolt
A	Ampere	kW	kilowatt
acc.	according	L	litre
API	American Petroleum Institute	L/min	litres per minute
approx.	approximately	LpA	sound pressure level operator's place
ASTM	American Society for Testing and Materials	LwA	measured sound power level
bar	Bar	m	metre
CECE	Committee for European Construction Equipment	m/s ²	metre per square second
CO ₂	carbon dioxide	m ³	cubic metre
dB	decibel	max.	maximum
DIN	Deutsches Institut für Normung (German Institute for Standards)	mm	millimetre
e.g.	for example	MPa	Megapascal
EMC	electromagnetic compatibility	N	Newton
EN	European standard	resp.	respectively
GL	Ground level	s	second
incl.	including	t	ton
ISO	International Organization for Standardization	V	Volt

General symbols

	Warning light		Swivel boom (left)
	Fuel indicator		Swivel boom (right)
	Engine oil indicator		Dozer up
	Charge indicator		Dozer down
	Glow indicator		Control lever direction
	Hydraulic oil		Control lever direction
	Travel speed		Rotary beacon
	Low speed		Display selector switch
	Forward travel		Auxiliary port enable switch
	Backward travel		Boom working light
	Raise boom		Cab working lights
	Lower boom		AUTO IDLE switch
	Arm crowd		AUTO IDLE indicator
	Arm dump		Fan
	Bucket crowd		Menu button
	Bucket dump		Overload warning switch
	Coolant temperature indicator		Information button
	Service interval indicator		Set clock indicator

	Overvoltage indicator		Key indicator
	Anti-theft system fault indicator		Wrong key indicator
	Insert key indicator		Registration mode complete indicator
	Pull out key indicator		Registration mode indicator
	Key registration indicator		No overload warning indicator
	Voltage supply indicator 5 V		Overload warning indicator
	Voltage supply indicator 12V		Raise control lever lock indicator
	Lower control lever lock indicator		Start engine indicator
	Coolant temperature sensor fault indicator		Controller Area Network indicator
	Auxiliary port indicator		Auxiliary port 1 indicator
	Auxiliary port 2 indicator		Auxiliary port not present indicator
	Selection right indicator		Selection up indicator
	Selection down indicator		Save entry indicator

General information

Foreword

These operating instructions apply only for the KUBOTA excavator models KX057-4, U48-4 and U55-4 complying with the following EC declaration of conformity (page 11).

Safety instructions, the rules and regulations for the use of excavators given in these operating instructions apply to the excavators mentioned in this documentation.

It is the responsibility of the owner(s):

- to ensure local, regional and national regulations are observed,
- to observe the bodies of rules (laws, regulations, guidelines, etc) stated in the operating instructions to ensure safe handling of the equipment,
- to ensure that the operating instructions are always available for the operating personnel and the information, such as notes, warnings and safety rules and regulations, are followed in all points.

The data in the operating instructions apply for all models. Information applying only a certain model or only optional equipment is highlighted e.g. (optional, KX057-4, U48-4 and U55-4).

The terms "front" and "direction of travel" refer to the view of the operator when seated on the operator's seat. Forward direction of travel means that the dozer is at the front when driving forwards as shown in the figure.

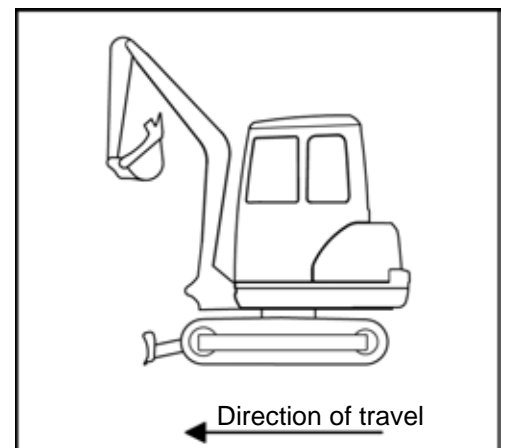

The symbols for operating and safety instructions are listed under "Safety symbols (page 15).

EC declaration of conformity



With the EC declaration of conformity, KUBOTA Baumaschinen GmbH certifies that the excavator is in conformity with the valid standards and regulations at the time of marketing. The CE conformity marking is located on the type plate and indicates compliance with the regulations.

If the excavator is modified or retrofitted without the approval of the manufacturer, the safety of the excavator may be affected, thus invalidating the EC declaration of conformity.

The EC declaration of conformity is attached to the operating instructions for delivery of the excavator.

Keep the EC declaration of conformity in a safe place and show it, if requested, to the responsible authorities.

Should the EC declaration of conformity get lost, please contact your KUBOTA dealer.

Date of issue of the operating instructions

The date of issue of the operating instructions is printed on the bottom right of the front page of the book.

Operating personnel

The duties of personnel with respect to operation, servicing, repairs and safety inspections must be set forth clearly by the owner.

Personnel in training are allowed to work on or with the excavator only under the supervision of an experienced operator.

Operator

According to industrial safety regulations, only persons who were instructed in the operation of the excavator, who have proven their qualification to the owner (employer) and who can be expected to perform their duties in a reliable way are allowed to operate the excavator independently.

Only trained and instructed personnel are allowed to work on or with the excavator.

Only instructed personnel are allowed to start the excavator and operate the controls.

Trained personnel

Trained personnel are skilled persons with a technical qualification who are able to determine damages to the excavator and perform repairs in their area of qualification (e.g. hydraulic or electrical engineering).

Skilled personnel

Based on their training and experience in their field, skilled personnel must have sufficient knowledge in excavator engineering and be familiar with the applicable national worker's protection regulations, safety regulations and the generally accepted technical rules so that they can assess the safe condition of the excavator.

Location of the operating instructions

The operating instructions must always be kept on the excavator. If the operating instructions have become illegible due to continuous use, the owner (operator) must order a replacement from the manufacturer.

There is a compartment (1) for the operating instructions behind the backrest of the operator's seat.

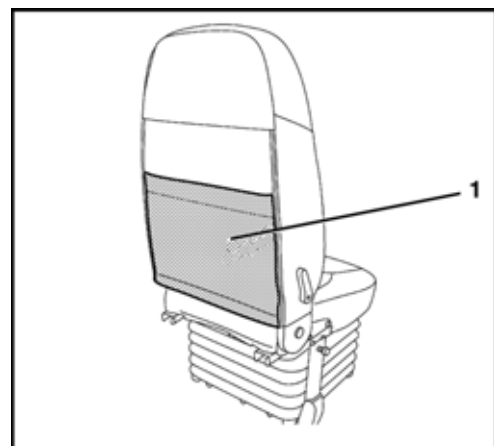

General information

Spare parts

Genuine spare parts can be ordered from KUBOTA dealers by stating the model and the serial # of the excavator.

The item numbers for the spare parts are indicated in the spare parts catalogue.

Safety rules

Basic safety instructions

- The EC machine utilization directive (2009/104/EC) dated 16/09/2009 applies for the operation of the aforementioned excavator.
- The information in these operating instructions applies for maintenance and repairs.
- National rules and regulations apply where applicable.

Duties, liability and warranty

A basic requisite for the safe handling and problem-free operation of the excavator is the knowledge of the safety instructions and safety regulations.

These operating instructions, in particular the safety instructions, must be followed by all persons working near or with the excavator. Above and beyond this, the safety rules and regulations applicable for the site must also be observed.

Hazards occurring during the handling of the excavator:

- The excavators are manufactured according to the state of technology and the recognized safety rules. Nevertheless, danger to the life and limbs of the operator or a third party, or damage to the excavator or to other property can occur. The excavator(s) may only be used
 - for the approved use and
 - in a completely safe operating state.

Malfunctions which can reduce safety must be repaired immediately.

Warranty and liability

The scope, period and form of the warranty are set forth in the sales and delivery conditions of the manufacturer. The operating instructions valid at the time of delivery shall be the basis for any warranty claims arising from errors in the documentation, see the date of issue of the operating instructions (page 12). The following applies above and beyond the sales and delivery conditions: No warranty or liability shall be assumed for personnel and property damages resulting from one or more of the following reasons:

- unapproved use of the excavator,
- improper starting, operation and maintenance of the excavator,
- operation of the excavator with defective safety devices or improperly installed or non-operational safety and protective devices,
- ignorance or non-observance of these operating instructions,
- insufficiently qualified or insufficiently instructed operating personnel,
- improperly performed repairs,
- unauthorised engineering changes to the excavator,
- poor surveillance of machine parts subject to wear,
- catastrophes caused by the effect of foreign objects or an act of God.

Safety rules

The owner must ensure at his own responsibility that

- the safety rules are observed (page 14),
- unapproved use (page 16) and unauthorised operation are excluded and
- the approved use (page 16) is ensured and the excavator is operated in accordance with the contractual conditions of use.

Safety symbols

The following terms and hazard symbols are used in these operating instructions:



Identifies important operating procedure information which may not be immediately evident to the operator.



Identifies operating procedures which must be followed exactly to prevent damage to the excavator or other property.



Identifies operating procedures which must be followed exactly to prevent danger to persons.



Identifies possible hazards in the handling of batteries.



Identifies possible hazards from caustic materials (battery acid).



Identifies possible hazards from explosive materials.



Prohibits the use of fire, ignition sources, and smoking.



Prohibits the spraying of water.



Identifies operating procedures for the proper disposal and storage of ensuing waste materials.

Approved use

The excavators specified in this operator's manual may only be used for to loose the ground, excavating, picking up, transporting and dumping soils, rocks and other materials, for work with the dozer or with a breaker. The load may be transported largely without driving the excavator. Do not exceed the maximum lifting capacity.

Approved use also includes:

- observation of all notes in these operating instructions,
- regular servicing,
- regular safety inspections.

Unapproved use

Any improper use – i.e. any deviation from the information in the "Approved use" section (page 16) of the excavator documented in these operating instructions – is considered an unapproved use. This also applies to the non-observance of the standards and guidelines listed in these operating instructions.

Hazards can occur in case of improper use. Such improper uses include:

- using the excavator to lift loads without suitable load lifting attachments,
- using the excavator in contaminated environments,
- using the excavator in closed rooms without insufficient ventilation,
- using the excavator under conditions of extreme temperatures (extreme heat or cold),
- using the excavator for underground works,
- using the excavator to transport persons in the bucket, and
- using the excavator for tearing down walls with the bucket.

Special duties of the owner

Owner of the excavator in the sense of these operating instructions is any person or company which uses the excavator itself or on whose order it is used. In special cases (e.g. leasing, rental), the owner is the person who must perform the duties arising from operation according to the conditions of the contract between owner and user of the excavator.

The owner must ensure that the excavator is only used properly and that any danger to the life and health of the user or others who are in the proximity of the user are eliminated. Furthermore, observance of the safety rules and regulations as well as the operating, maintenance and repair regulations must be ensured. The owner must make sure that all operators and users have read and understood these operating instructions.

Persons who work with or on the excavator must be provided by the operator with, and where applicable use suitable personal protective equipment (PPE), for example suitable working clothes, safety shoes, safety helmets, eye protection, ear protection and air-filter masks. The owner/employer bears the main responsibility for the PPE, which is specified by the safety rules for particular types of activity.

Waste such as old oil, fuel, hydraulic fluid, coolant and batteries comes under the category of toxic waste and can be a hazard to the environment, people and animals.

Disposal must be undertaken in an appropriate way, according to legally prescribed pollution control and safety regulations.

If you have questions about the correct disposal or storage of refuse and toxic waste, contact your KUBOTA dealer or a local waste management contractor.

Noise emission and vibration

The values specified in this manual have been identified in the test cycle at an identical machine and are valid for a standard equipment machine. The determined values are shown in the Technical Data (page 39).

Noise emission

The noise levels were determined using the method of determining the guaranteed sound pressure level of ISO 4871 based on directive 2000/14/EC, appendix VI.

The noise levels shown are not applicable for the determination of additional workplace noise emissions. The actual noise levels may need to be determined directly at the workplaces, subject to actually existing conditions (other noise sources, special operating conditions, sound reflections).

Depending on the actual noise emissions the owner must provide the necessary personal protective equipment to the operator (ear protection).



*Noise of a noise level of more than 85 dB (A) can cause hearing damage.
From a noise level of 80 dB (A), the use of an ear protection is recommended.
From a noise level of 85 dB (A), the operator must wear an ear protection.*

Vibrations

The vibrations at the machine have been determined at an identical machine.

The vibration stress on the operator over a longer period of time must be determined by the owner at the site of application, in compliance with directive 2002/44/ EC in order to consider individual magnitudes of influence.

Safety labels on the excavator

Keep the safety and warning symbols (labels) on the excavator clean and legible, replacing them if necessary.

The positioning of the safety symbols is illustrated in the following figures.

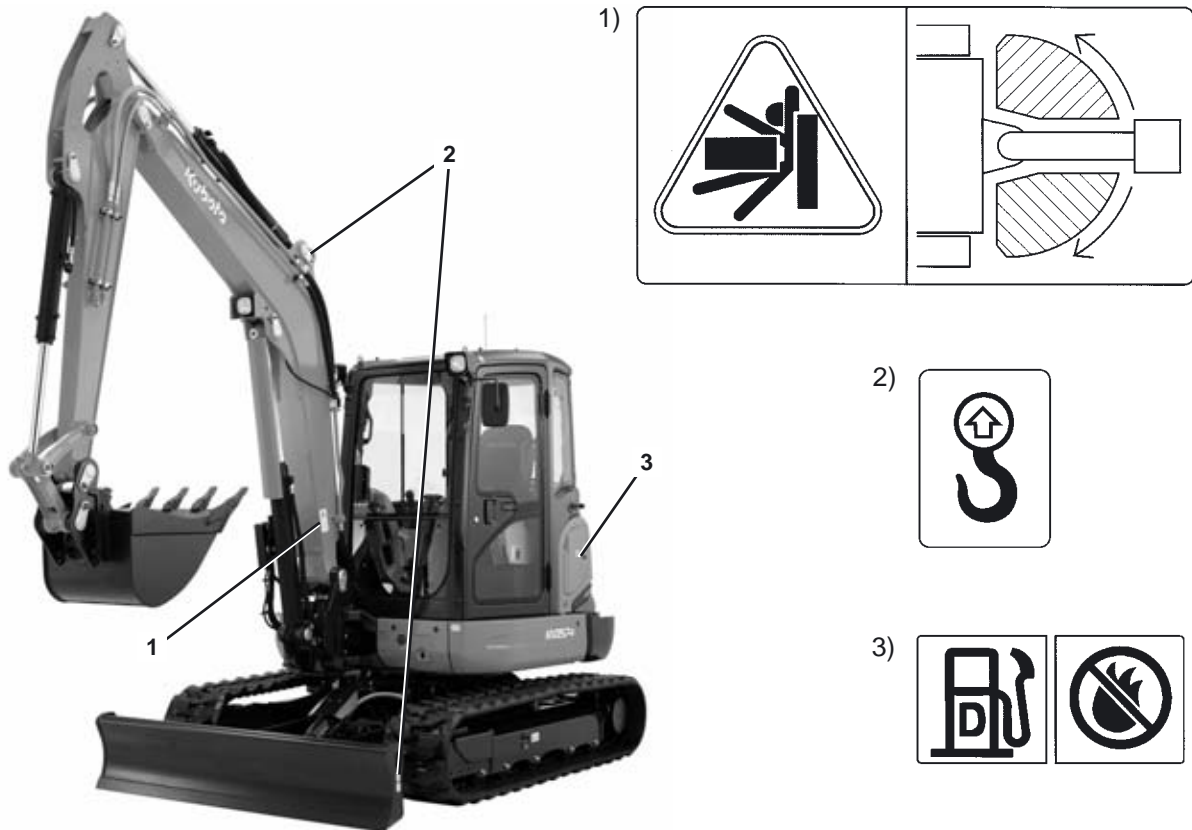

- 1) Code #: 69198-5722-0 (both sides)
Do not enter the swing area.
- 2) Code #: RC108-5796-0 (both sides)
Attachment point for lifting gear.
- 3) Code #: RB238-5736-0
Diesel fuel only, no open fire.

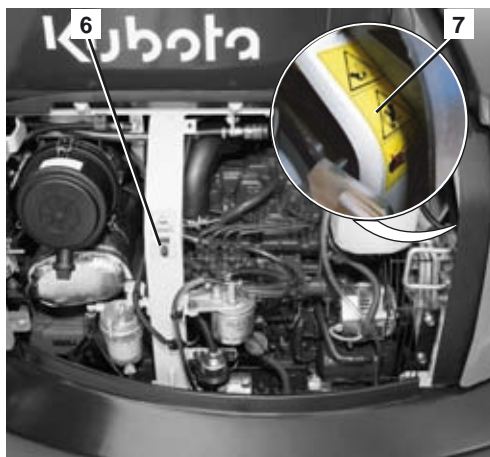
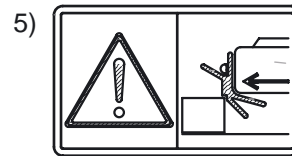
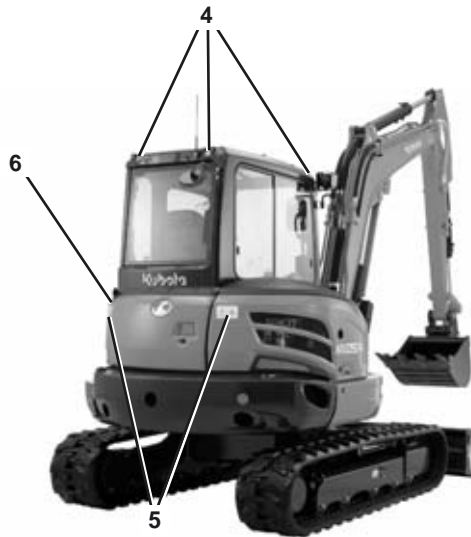

- 4) Code #: RG109-5796-0
Not an attachment point for lifting gear.
- 5) Code #: RD809-5725-0
Do not enter the manoeuvring area.
- 6) Code #: TA040-4958-0
Do not touch hot parts, such as exhaust muffler, etc.
- 7) Code #: RC418-5737-0
Keep away from fan and V-belt.

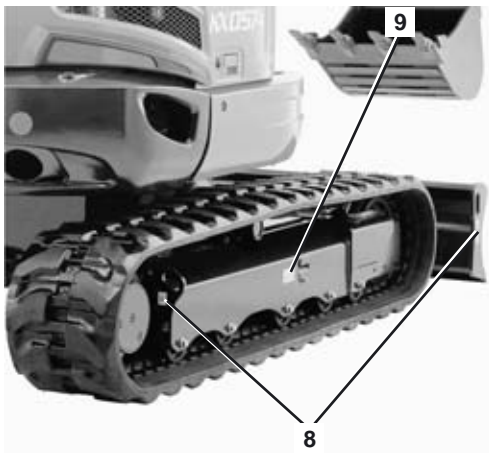

8)

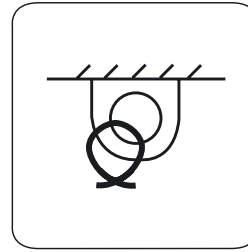

9)



- 8) Code #: RD809-5733-0 (both sides)
Use the attachment point only for clamping the excavator securely to a transport vehicle.
- 9) Code #: RD809-5795-0 (both sides)
For information about loosening the crawler, consult the operating instructions.



10)



- 10) Code #: RD809-5714-0
Emergency exit.

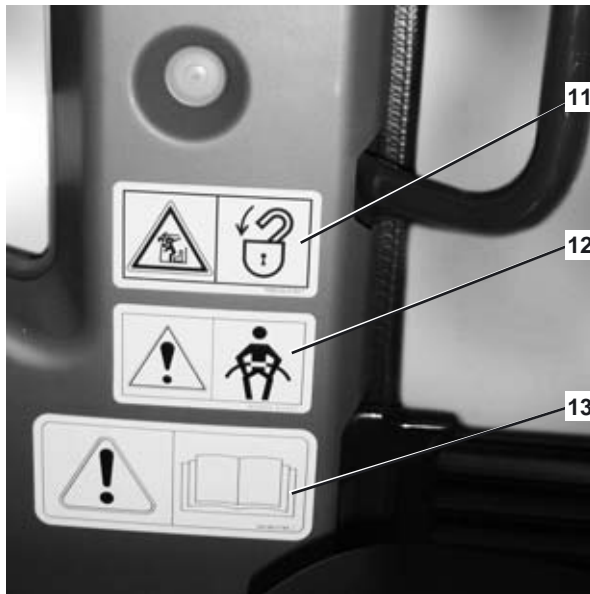

- 11) Code #: RB419-5793-0
Risk of injury through windshield getting out of place. Always lock the windshield.
- 12) Code #: RD809-5743-0
Caution: Always fasten the seat belt to avoid an increased risk of injury.
- 13) Code #: 69198-5784-0
Attention: Read the operating instructions and make sure that the instructions have been understood before starting or operating the excavator.

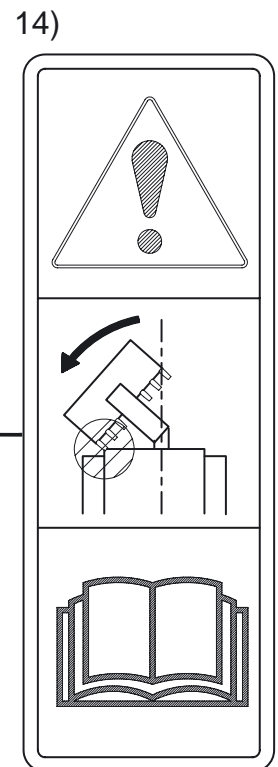

- 14) Code #: RD809-5739-0
When using a wider or deeper bucket, take good care when swinging or retracting the front attachments to make sure that the bucket does not hit the cab.

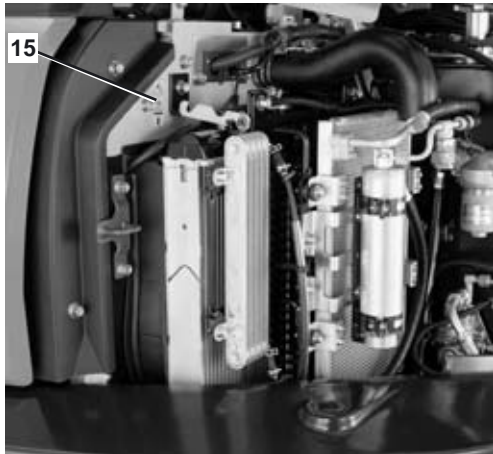

15)



- 15) Code #: RA028-5724-0
Radiator: Risk of burns.

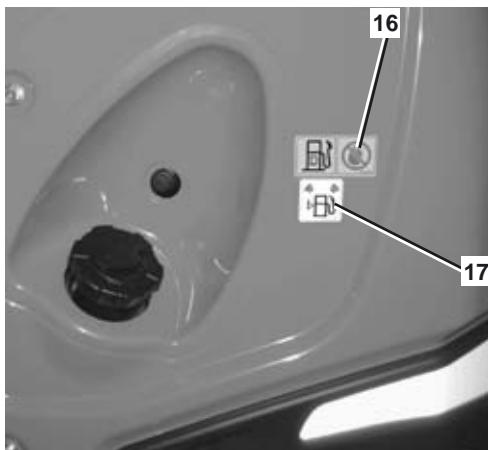

- 16) Code #: RB238-5736-0
Diesel fuel only, no open fire.
- 17) Code #: RD451-5748-0
Fill level monitor when refuelling.

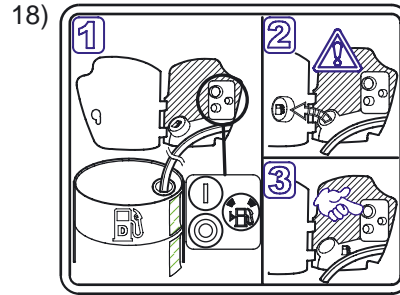
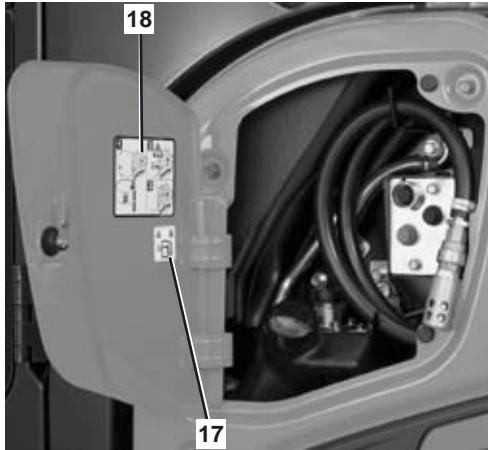

- 18) Code #: RD359-5726-0
 Operation of the suction pump.
 (Optional KX057-4)

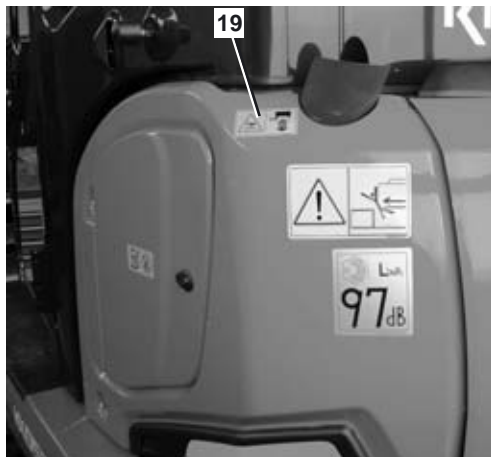

- 19) Code #: RD809-5745-0
 Do not touch hot parts, such as exhaust muffler, etc.



20) Code #: RD359-5747-0
KX057-4

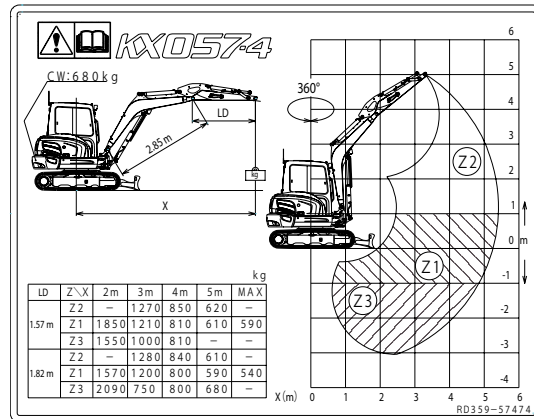

20) Code #: RD459-5747-0
U48-4

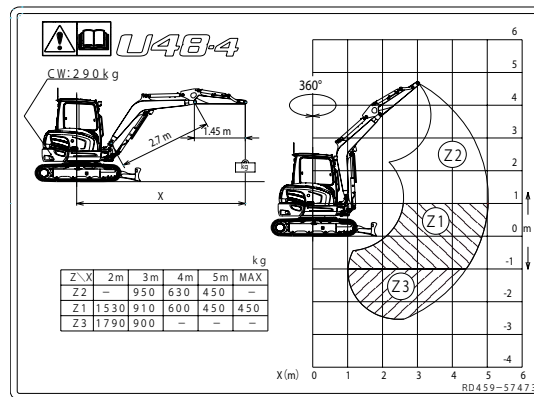

20) Code #: RD559-5747-0
U55-4

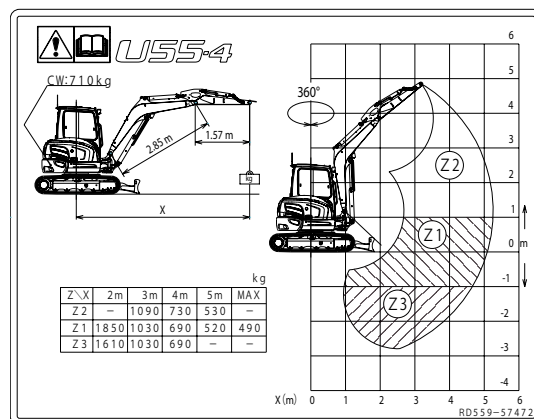

21) Code #: RH849-5749-0

Risk of accidents by exceeded load when lifting!

When exceeding the nominal load, a beep sounds and a warning light illuminates.

- Turn on overload warning function before starting a lifting operation!

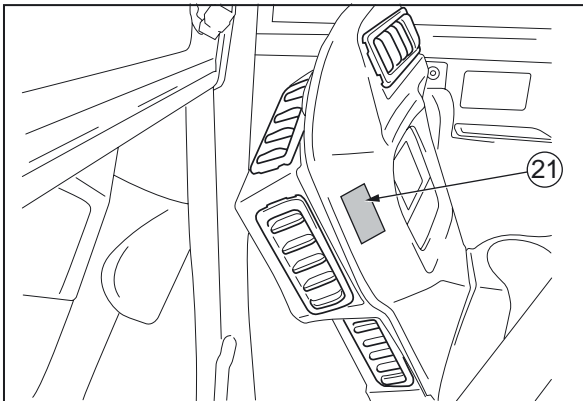

Safety devices

Before starting the excavator, all safety devices must be installed properly and operational. No manipulation of safety devices, e.g. the shorting of limit switches, is allowed.

Protective devices may only be removed after

- the excavator is standing still and the engine is stopped
- and secured against restarting (starter switch in STOP position and key removed).

Locking the controls

The control levers (3 and 6), on the right and left, the drive levers (1), the boom swing pedal (2), and the dozer control lever (5) are not operational when the console (7) is raised. This circumstance allows safe getting on and off. The console is unlocked and raised with the control lever lock (4).

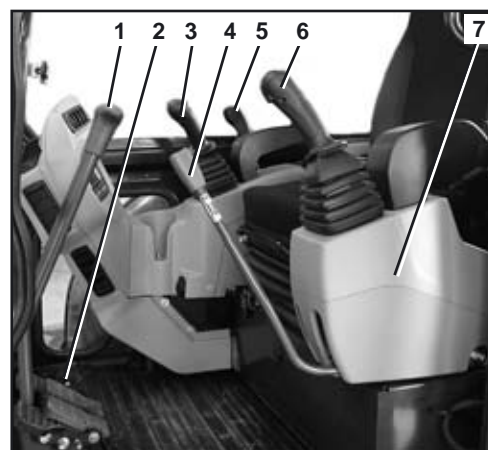

Engine stop knob

The engine is stopped when the main key switch is turned to the STOP position.

If the engine cannot be turned off, please operate the engine stop knob switch in order to turn off the engine.

To stop the engine:

- Pull the knob (1) until the engine stops.
- After the engine has stopped, push in the knob.

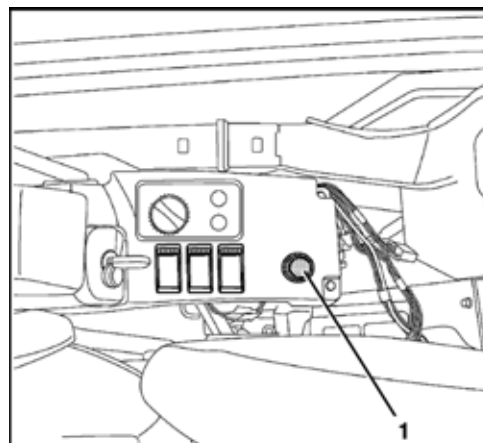

Safety rules

Canopy (FOPS) and roll-over protection (ROPS)

- The excavator is equipped with a tested canopy (FOPS) and roll-over protection (ROPS).
- The seat belt must be fastened while the excavator is being operated.
- There must be no structural changes to the canopy or roll-over protection.
- In the event of damage, please contact your KUBOTA dealer. (Do not repair!)
- Never operate the excavator without canopy or roll-over protection.

Emergency hammer

In case of an accident where the excavator cab door and windows can not be opened, the operator can break the window panes with the emergency hammer (1).



When breaking the window pane, close your eyes and cover them with an arm.

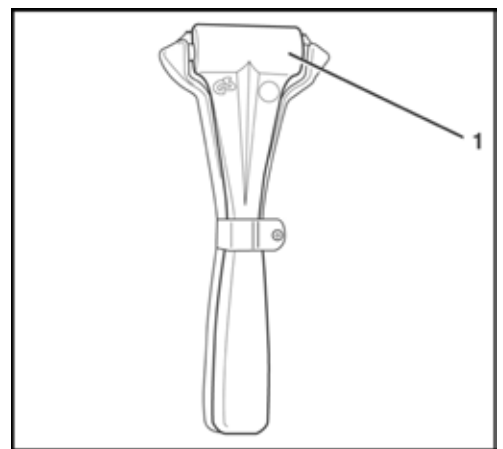

Pipe safety valve

The pipe safety valve prevents the load from suddenly lowering during lifting operation in case a pipe or hose bursts.

The pipe safety valve (1) is attached directly to the hydraulic port of the boom cylinder, arm cylinder or dozer cylinder.

Excavators that will be used in the lifting operation, must be equipped with at least a pipe safety valve on the boom and arm, together with an overload warning function (page 28) according to EN 474-5.

An additional pipe safety valve in accordance with EN 474-1 must be installed before using the dozer for lifting operation support.

To equip the excavator for the lifting operation, contact your KUBOTA specialist dealer.

The pipe safety valve is adjusted in the factory on the particular excavator. Manipulating the pipe safety valve will void the warranty.



Any manipulation can result in substantial personal injuries, even death, and is therefore strictly forbidden.

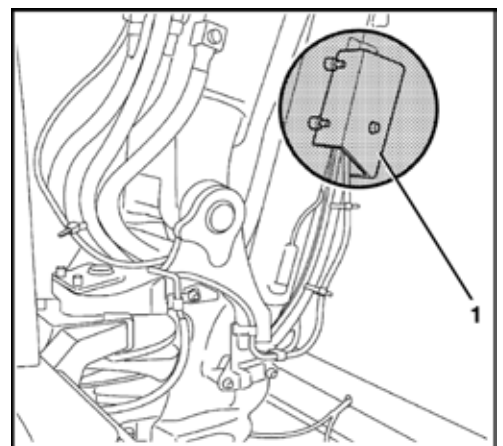

The manipulation and repair of the pipe safety valves is forbidden. They may only be replaced by your KUBOTA dealer as a kit.

Overload warning function

An overload warning function informs the operator immediately if there is an overload. The warning system is controlled by the pressure switch at the pipe safety valve. The load is measured by the pressure at the base of the cylinder. Any overpressure triggers the warning device.

The warning device is activated with the overload warning switch (1). In the event of an overload, an acoustic signal sounds and "Exceed Rated Load" appears in the display.

An overload warning function is only available when the excavator is equipped for the lifting operation. To equip the excavator for the lifting operation, contact your KUBOTA specialist dealer.

Excavators that will be used in the lifting operation, must be equipped with at least a pipe safety valve on the boom and arm, together with an overload warning function according to EN 474-5. An additional pipe safety valve in accordance with EN 474-1 must be installed before using the dozer for lifting operation support.

When changing from rubber crawlers to steel crawlers, or from steel crawlers to rubber crawlers, or when modifying the length of the arm, please contact your KUBOTA dealer.

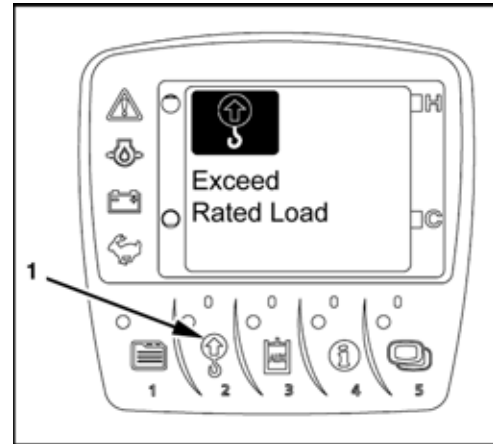

The overload warning function must be enabled during any lifting operation to prevent personal injuries and damage to equipment.

Hazards coming from the hydraulic system

If hydraulic oil gets into the eyes, rinse them immediately with clear water and subsequently seek medical aid.

Do not allow hydraulic oil to contact the skin or clothing. Skin parts which may have come in contact with hydraulic oil must be washed with water and soap immediately, if possible. Do this thoroughly and repeatedly, otherwise there is a risk of damage to the skin.

Immediately take off any clothes dirtied or soaked with hydraulic oil.

Persons who have inhaled hydraulic oil vapours (mist) should be taken to a doctor immediately.

If leaks have occurred in the hydraulic system, the excavator may not be taken into operation or, if in operation, operation must cease at once.

Do not use the naked hand to search for leaks; always use a piece of wood or cardboard. Protective clothing (eye protection and gloves) must be worn when seeking leaks.

Leaking hydraulic oil must be bound immediately with an oil binding agent. The contaminated oil binding agent must be stored in suitable containers and in accordance with the valid regulations.

Fire protection



The excavator components and attachments (in particular the engine and the exhaust system) reach high temperatures even at normal working conditions. An electric installation which is damaged or not properly serviced may lead to flashovers and/or electric arcs. The following Fire Protection Guidelines may help you ensure the maintenance and efficiency of your equipment and minimize fire hazards.

- Remove any accumulated dirt adjacent to hot components, e.g. engine, muffler, exhaust manifold/tubes, etc. If the machine is being used to full capacity, the cleaning procedure should be performed more frequently.
- Accumulated residues from plants and trees, or any other flammable materials, should be removed from the machine. This must be observed in particular in the proximity of the engine and the exhaust system, but also at the swivel frame, the track frame, and the boom.
- Check the condition and wear of all fuel lines and hydraulic hoses. Any defective parts should be replaced immediately in order to avoid leakage.
- Electric lines and connections must be checked regularly for signs of damage. Damaged components and lines must be replaced or repaired before starting up the machine. All electric connections must be kept clean and solid.
- Exhaust pipes and mufflers must be checked daily for leaks, damage and any loose or missing joints. Leaking or damaged exhaust system components must be replaced or repaired before starting up the machine.
- Always keep a multipurpose fire extinguisher at or close to the machine. Make yourself familiar with the operation of the fire extinguisher. In the event of fire in the electrical or hydraulic system, use a CO₂ fire extinguisher to combat the fire.
- For attaching a fire extinguisher (1) two threads (2) have been inserted in the cab construction on the left side behind the driver's seat.



A fire extinguisher is not included in the basic equipment of the machine.

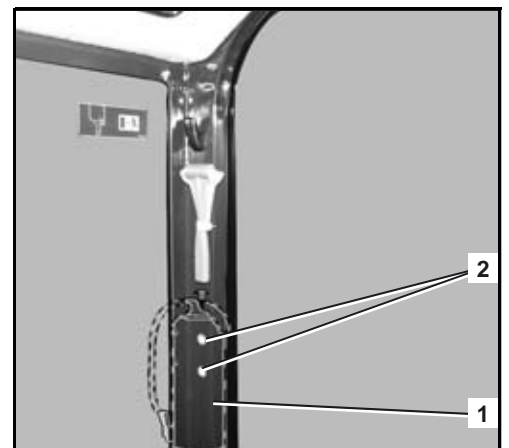

Recovery, loading and transport

Safety rules for recovery

- For recovery of the excavator, a towing vehicle of at least the same weight class as the excavator must be used.
- A tow bar must be used for the recovery. If a tow rope is used, an additional vehicle to brake the excavator must also be attached. The tow bar or tow rope must be suitable for the recovery of the excavator in respect of the towed load. Do not use damaged recovery aids.
- Do not step into the danger zone between the vehicles during the recovery procedure. If a tow rope is used, keep a distance of at least 1.5 times the length of the rope.
- Use the towing eye on the track frame for the recovery.
- The above safety rules also apply if the excavator is used as the towing or recovery vehicle.
- Observe the admissible values for the towed load and the maximum pressing load vertical down on the towing eye during recovery, see „Specifications“ (page 39).

Safety rules while loading with a crane

- Crane and lifting gear must be suited for the absorption of the load to be lifted and be approved.
- Before the use of the crane and the lifting gear, make sure that the specified safety inspections at regular intervals have been carried out and that the crane and lifting gear are in good working order and impeccable condition.
- The excavator may only be lifted at the points provided. Do not attach the lifting gear to the cab roof as this can lead to substantial damage.
- Never attach a crane hook to the lower edge of the dozer! The crane hook can slip off sideways while lifting and the excavator may fall off.
- Always adhere to the valid safety regulations for the lifting of loads.
- The excavator must be secured with a holding rope when it is being lifted.
- The crane operator is responsible for the observance of these safety rules.

Safety rules for transport

- The ramps must have a sufficient load capacity for bearing the weight of the excavator. They must be placed securely on the transport vehicle and fastened.
- Support the loading area at the rear of the transport vehicle with sufficiently dimensioned supports.
- The ramps must be wider than the track of the excavator and have footboards on the side.
- The transport vehicle must be designed for the load of the excavator.
- Place the left and the right ramp so that the centre line of the transport vehicle is aligned with the centre line of the excavator to be loaded.
- Do not drive the excavator onto the transport vehicle without ramps and with the boom.
- In the transport vehicle, pull the parking brake and secure the individual wheels of the transport vehicle at the front and rear, respectively, with chocks.
- Secure the excavator against sliding on the transport vehicle with chocks or chains or with suitable tiedown straps. The chocks must be secured at the crawlers and on the transport vehicle with suitable means. The operator of the transport vehicle is responsible for the secure fastening of the excavator on the vehicle.
- A guide is required for driving the excavator onto and off the transport vehicle. The guide is responsible for the safe loading. The excavator may only be moved on instruction of the guide; the operator and guide must always have eye contact. If this is not possible, the operator must stop the excavator immediately.
- When driving with an excavator loaded, always keep a clearance of 1.0 m to overhead power lines. Observe the applicable traffic rules and regulations.

Recovery



Adhere to the safety rules (page 14) and the safety rules for recovery (page 30).



A recovery is only allowed over a short distance and at walking speed (0.5 m/s ~ 1.0 m/s).

- Attach the tow bar or tow rope to the attachment point (1) on the excavator and to the towing vehicle.

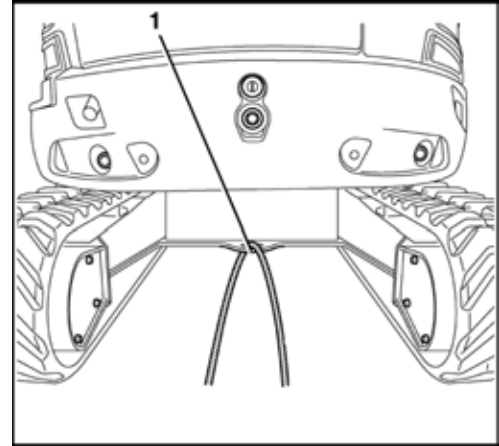

- If the attachment point of the excavator is not accessible, a tow rope can also be fastened around the centre of the dozer.
- During the recovery procedure, the operator must be seated on the operator's place.
- Drive slowly with the towing vehicle to avoid abrupt loads.

Hoisting the excavator with a crane



Adhere to the safety rules (page 14) and the safety rules for hoisting the excavator with a crane (page 30).

- Bring the excavator to the lifting position (see figure) on level ground.
- Lift the dozer until the dozer cylinders are fully retracted. Also see the "Operating the controls during excavation work" section) (page 78).

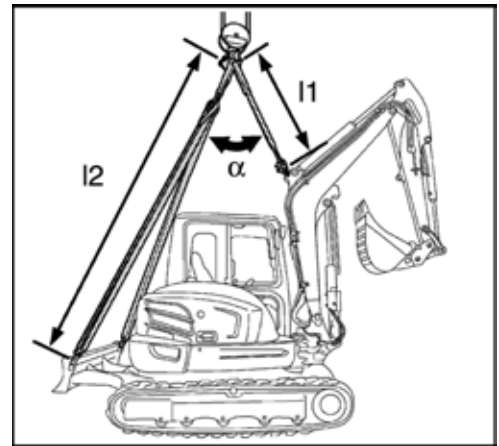

- Bring the boom in line with the longitudinal axis of the swivel frame.
- Completely extend the boom cylinder, arm cylinder and bucket cylinder.
- Swivel the swivel frame so that the dozer is located at the rear.
- Close and lock the door and covers.

	α (°)	l 1 (mm)	l 2 (mm)
KX057-4	< 51	1680	4280
U48-4	< 55	1250	3770
U55-4	< 57	1150	3805



The excavator may only be lifted at the points provided. Do not attach the lifting gear to any other eyes or areas as this can lead to substantial damage.

Recovery, loading and transport

- Attach the lifting gear with shackles to the lifting eyes (1) on each side of the dozer.

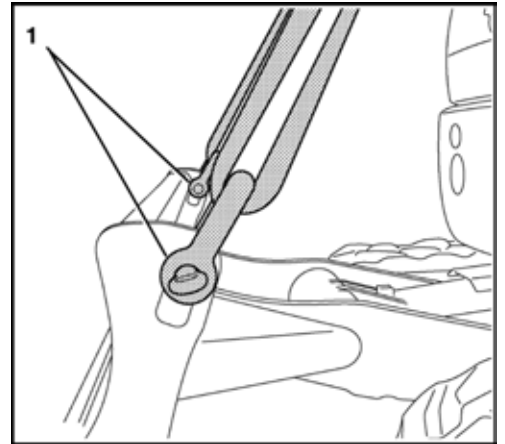

- Attach the lifting gear with shackles to the lifting eyes (1) on each side of the boom.

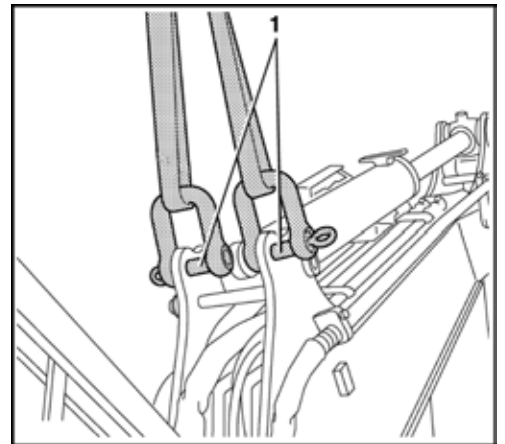

- As soon as the lifting gear is attached to the excavator, press cloths between lifting gear and excavator to protect the excavator.
- Always keep the machine level. Be sure that the centre line of the crane hook is aligned as exactly as possible with the centre line of the excavator and that the lifting angle is as specified. Lift the excavator.

Transport on a flat bed trailer



Adhere to the safety rules (page 14) and the safety rules for transport (page 31).

- Place the loading ramps on the transport vehicle at an angle of 10° to 15°. Observe the track width. Safely attach the ramps to the transport vehicle to make sure they cannot slide while driving upwards.

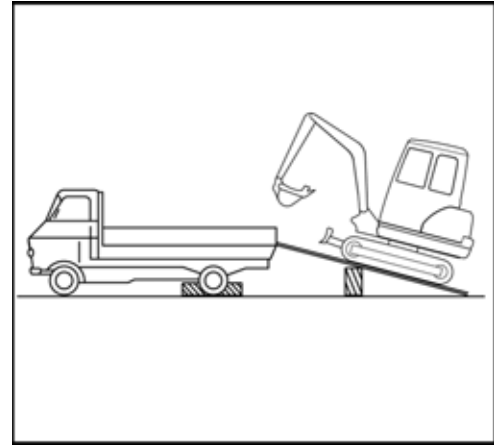

Do not turn or steer while driving up the ramps; if necessary, reverse the excavator and drive up again after realigning it.

- Bring the excavator exactly into line with the ramps and drive up straight. Lower the dozer onto the loading area.



*Caution! Danger!
No person is allowed to stand on the loading area during swivelling. Risk of bruising.*



Take care during swivel operations. The front attachments could hit the transport vehicle. This could damage the transport vehicle and the excavator.

- Turn swivel frame by 180° until the front attachments face the rear of the transport vehicle.

For securing the vehicle, tie down the points as shown in the figure.

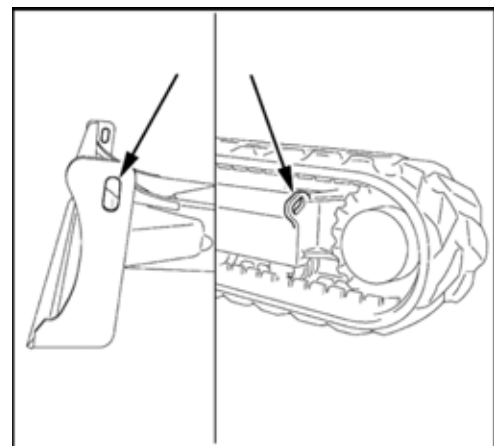

Recovery, loading and transport

- For safe attachment, fully crowd the arm and bucket and lower the boom until the bucket linkage touches the loading area.
- Secure the chains and the dozer with beams (2).
- Secure the excavator against sliding on the transport vehicle with chocks or chains (1) (note the vehicle weight).

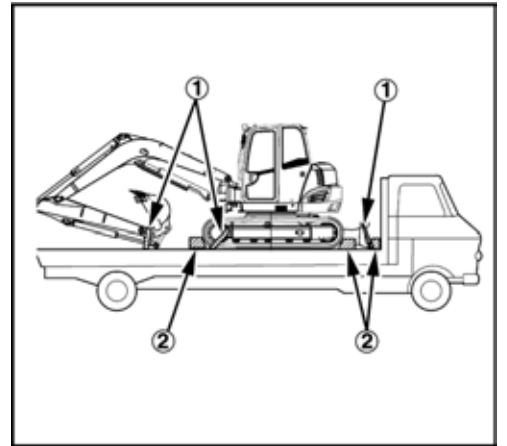

- Lock the excavator after hoisting.

Description of the excavator

Model overview

The excavator is available in three models KX057-4, U48-4 and U55-4.

Model KX057-4, U48-4 and U55-4

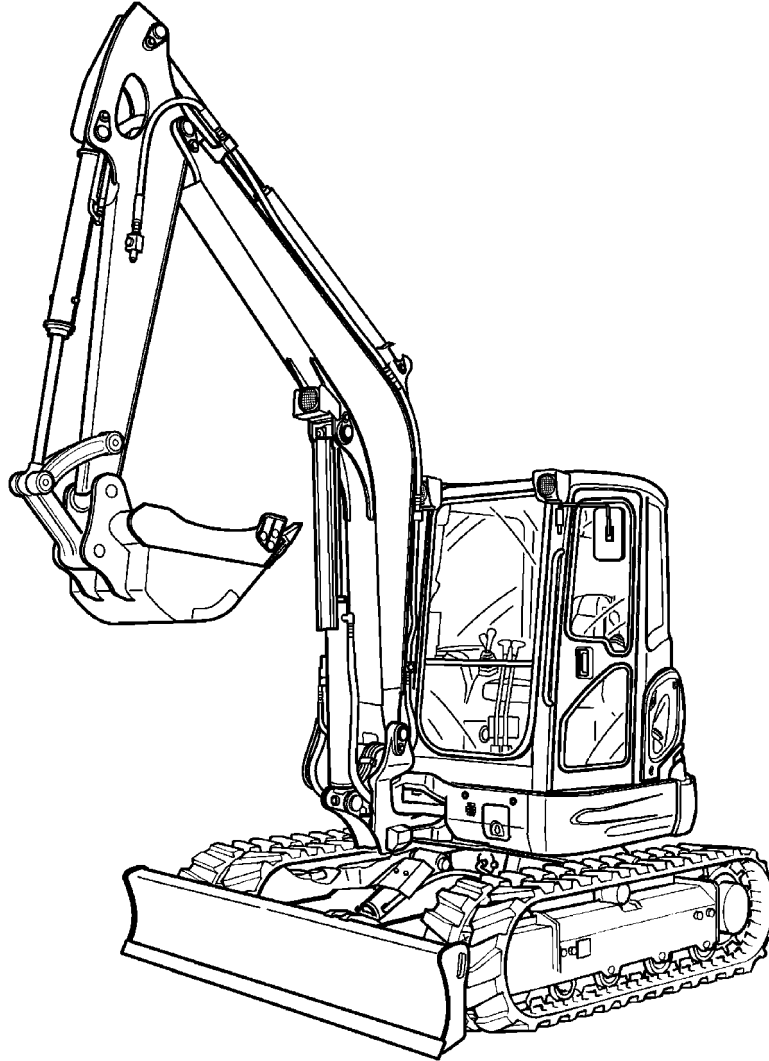

Description of the excavator

Dimensions

The dimensions of the models KX057-4, U48-4 and U55-4 can be found in the following illustrations including tables.

Dimensions KX057-4, U48-4 and U55-4

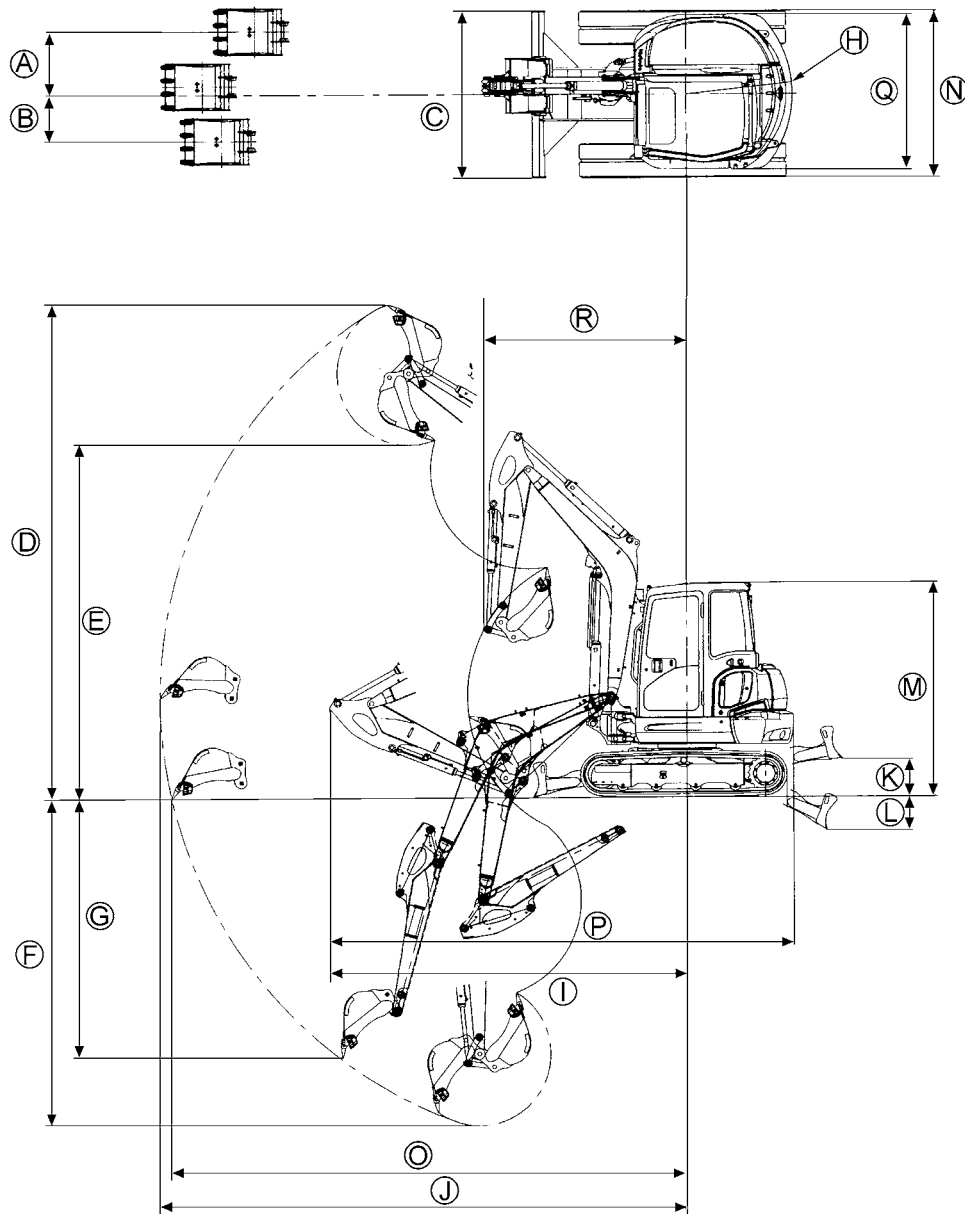



All dimensions in mm with original KUBOTA bucket and rubber crawlers

KX057-4	A	B	C	D	E	F	G	H	I	J
1*	750	550	1960	5820	4160	3890	3070	1270	4250	6260
2*	750	550	1960	5665	4005	3630	2830	1270	4235	6025
	K	L	M	N	O	P	Q	R		
1*	440	410	2550	1960	6130	5520	1830	2420		
2*	440	410	2550	1960	5880	5505	1830	2380		

U48-4	A	B	C	D	E	F	G	H	I	J
3*	815	625	1960	5440	3770	3380	2670	990	4135	5850
	K	L	M	N	O	P	Q	R		
3*	440	410	2550	1960	5710	5330	1830	2390		

U55-4	A	B	C	D	E	F	G	H	I	J
4*	815	625	1960	5665	4005	3630	2830	1045	4315	6105
	K	L	M	N	O	P	Q	R		
4*	440	410	2550	1960	5960	5500	1830	2460		

Arm version

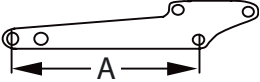
Name		Type	
1*	Arm 1820 mm		A = 1820 mm
2*	Arm 1570 mm		A = 1570 mm
3*	Arm 1450 mm		A = 1450 mm
4*	Arm 1570 mm		A = 1570 mm

Specifications

Following are the specifications for these series.

Specifications KX057-4

		KUBOTA Excavator		
Model name		KX057-4		
Type		Cab		
Operating weight	(with operator and standard bucket 135 kg) kg	Rubber crawler	Steel crawler	
		5545	5645	
Bucket (KUBOTA)	Volume (SAE/CECE)	0.17/0.15 m ³		
	Width with side cutters attached	680 mm		
Engine	Type	4-cylinder diesel engine, water-cooled		
	Model name	KUBOTA V2607-DI-E3-BH		
	Displacement	2615 cm ³		
	Engine performance (ISO 9249)	33.8 kW		
	Rated speed	2200 1/min		
Performance	Swivel speed (swivel frame)		9.3 1/min	
	Vehicle speed	Travel speed km/h	4.9	
		Low speed km/h	2.8	
	Ground pressure (without operator)	kPa (kgf/cm ²)	31.4 (0.320)	31.9 (0.326)
	Climbing performance		% (degrees) 36 (20)	
	Max. lateral sway		% (degrees) 27 (15)	
Dozer (width x height)		1960 x 410 mm		
Swing angle of the boom	Left	70 degrees		
	Right	55 degrees		
Auxiliary port 1	Max. flow rate (theoretical)		75 L/min	
	Max. pressure	MPa	20.6	
		bar	206	
Auxiliary port 2	Max. flow rate (theoretical)		37 L/min	
	Max. pressure	MPa	19.1	
		bar	191	
Fuel tank capacity		75 L		
Pulling capacity at the towing eyes		20500 N		
Vertical load at the towing eyes		2200 N		
Noise level	LpA	79 dB (A)		
	LwA	97 (2000/14/EC) dB (A)		
Vibration at the drive levers*		m/s ² < 2.71		
Vibration at the control levers*		m/s ² < 4.75		
Vibration at the operator's seat*		m/s ² < 0.5		
Vibration at the bottom plate*		m/s ² < 0.97		
Vibration at the wrist rest*		m/s ² < 2.90		

* These values are measured under specific conditions at maximum engine speed and can deviate, depending on the operating situation.

Specifications U48-4

			KUBOTA Excavator	
Model name			U48-4	
Type			Cab	
Operating weight	(with operator and standard bucket 125 kg)	kg	Rubber crawler	Steel crawler
			4775	4875
Bucket (KUBOTA)	Volume (SAE/CECE)	m ³	0.14/0.12	
	Width with side cutters attached	mm	600	
Engine	Type	4-cylinder diesel engine, water-cooled		
	Model name	KUBOTA V2607-DI-E3-BH		
	Displacement	cm ³	2615	
	Engine performance (ISO 9249)	kW	29.8	
	Rated speed	1/min	2200	
Performance	Swivel speed (swivel frame)		1/min	
	Vehicle speed	Travel speed km/h		4.9
		Low speed km/h		2.8
	Ground pressure (without operator)	kPa (kgf/cm ²)	27.0 (0.275)	27.6 (0.281)
	Climbing performance		% (degrees)	
	Max. lateral sway		% (degrees)	
Dozer (width x height)		mm		1960 x 410
Swing angle of the boom	Left	degrees	70	
	Right	degrees	55	
Auxiliary port 1	Max. flow rate (theoretical)		L/min	
	Max. pressure	MPa		75
		bar		20.6
Auxiliary port 2	Max. flow rate (theoretical)		L/min	
	Max. pressure	MPa		37
		bar		20.6
Fuel tank capacity		L		206
Pulling capacity at the towing eyes		N		68
Vertical load at the towing eyes		N		20500
Noise level	LpA		dB (A)	
	LwA		(2000/14/EC) dB (A)	
Vibration at the drive levers*		m/s ²		78
Vibration at the control levers*		m/s ²		96
Vibration at the operator's seat*		m/s ²		< 2.71
Vibration at the bottom plate*		m/s ²		< 4.75
Vibration at the wrist rest*		m/s ²		< 0.5
				< 0.97
				< 2.90

* These values are measured under specific conditions at maximum engine speed and can deviate, depending on the operating situation.

Specifications U55-4

		KUBOTA Excavator		
Model name		U55-4		
Type		Cab		
Operating weight	(with operator and standard bucket 130 kg)	Rubber crawler	Steel crawler	
	kg	5400	5500	
Bucket (KUBOTA)	Volume (SAE/CECE)	0.16/0.13		
	Width with side cutters attached	650		
Engine	Type	4-cylinder diesel engine, water-cooled		
	Model name	KUBOTA V2607-DI-E3-BH		
	Displacement	2615		
	Engine performance (ISO 9249)	33.8		
	Rated speed	2200		
Performance	Swivel speed (swivel frame)	9.3		
	Vehicle speed	Travel speed km/h	4.9	
		Low speed km/h	2.8	
	Ground pressure (without operator)	kPa (kgf/cm ²)	30.5 (0.311)	31.1 (0.317)
	Climbing performance	% (degrees)	36 (20)	
	Max. lateral sway	% (degrees)	27 (15)	
Dozer (width x height)		1960 x 410		
Swing angle of the boom	Left	70		
	Right	55		
Auxiliary port 1	Max. flow rate (theoretical)	75		
	Max. pressure	MPa	20.6	
		bar	206	
Auxiliary port 2	Max. flow rate (theoretical)	37		
	Max. pressure	MPa	19.1	
		bar	191	
Fuel tank capacity		68		
Pulling capacity at the towing eyes		20500		
Vertical load at the towing eyes		2200		
Noise level	LpA	78		
	LwA	96 (2000/14/EC) dB (A)		
Vibration at the drive levers*		< 2.71		
Vibration at the control levers*		< 4.75		
Vibration at the operator's seat*		< 0.5		
Vibration at the bottom plate*		< 0.97		
Vibration at the wrist rest*		< 2.90		

* These values are measured under specific conditions at maximum engine speed and can deviate, depending on the operating situation.

Identification of the excavator

The type plate of the excavator is located at the front of the swivel frame. The owner should enter the stamped data in the field on the back of the front cover.

1. CE marking
2. Serial #
3. Max. pulling capacity at the towing eyes
4. Max. vertical load at the towing eyes
5. Product ID number PIN
6. Year of construction
7. Engine performance
8. Operating weight
9. Model name
10. Manufacturer
11. Representative

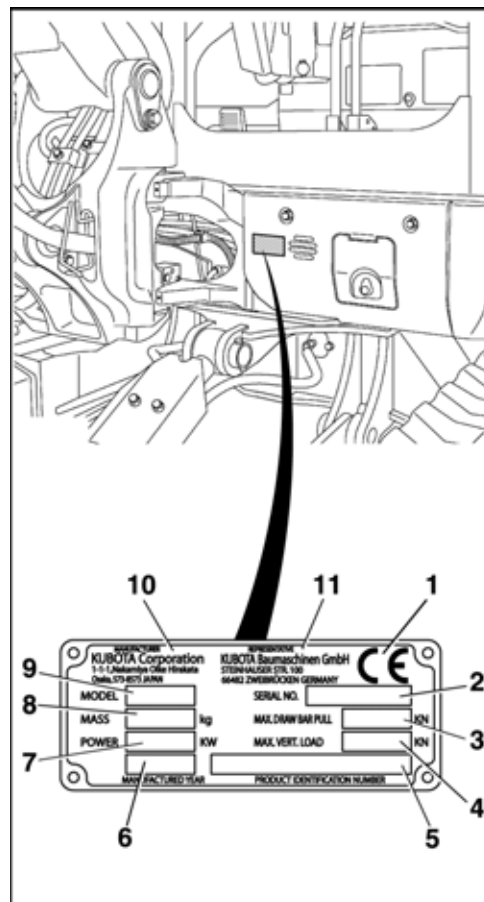

Serial # of the machine

The machine serial # (1) is stamped on at the track frame in the area of the swing bracket.

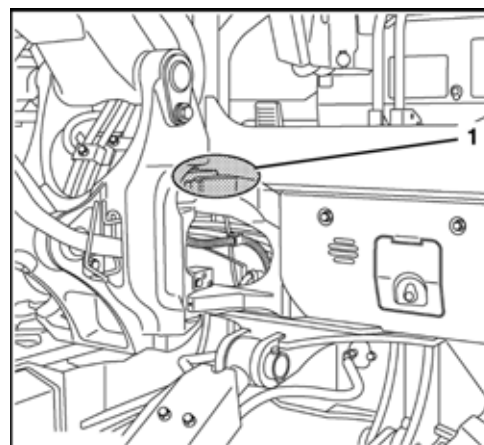

Description of the excavator

Engine number

The engine number (1) is affixed to the engine block.

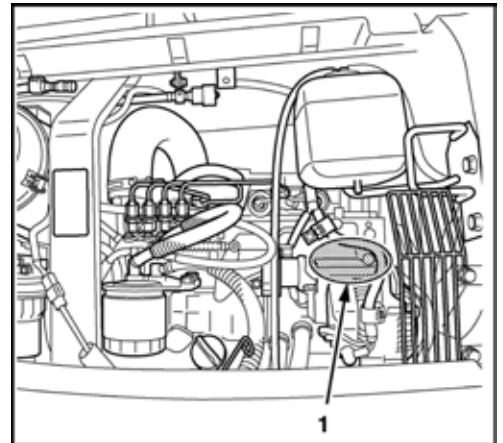

Equipment

The standard equipment of the excavator can be enhanced by optional equipment (accessories).

Standard equipment

This model has the following standard equipment:

- Operating instructions with protective cover
- Spare parts catalogue
- Filter wrench
- Grease gun
- Spare fuses (50 A, 80 A)
- Guarantee

Stow the filter wrench and other tools in the tool compartment (page 51).

The spare parts catalogue, guarantee and spare fuses can be stowed together with the operating instructions (page 12).

Stow the grease gun (1) behind the right cover next to the hydraulic system.

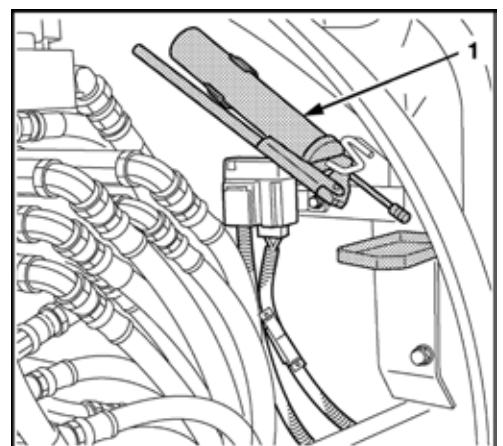

Assembly and functions

Component overview

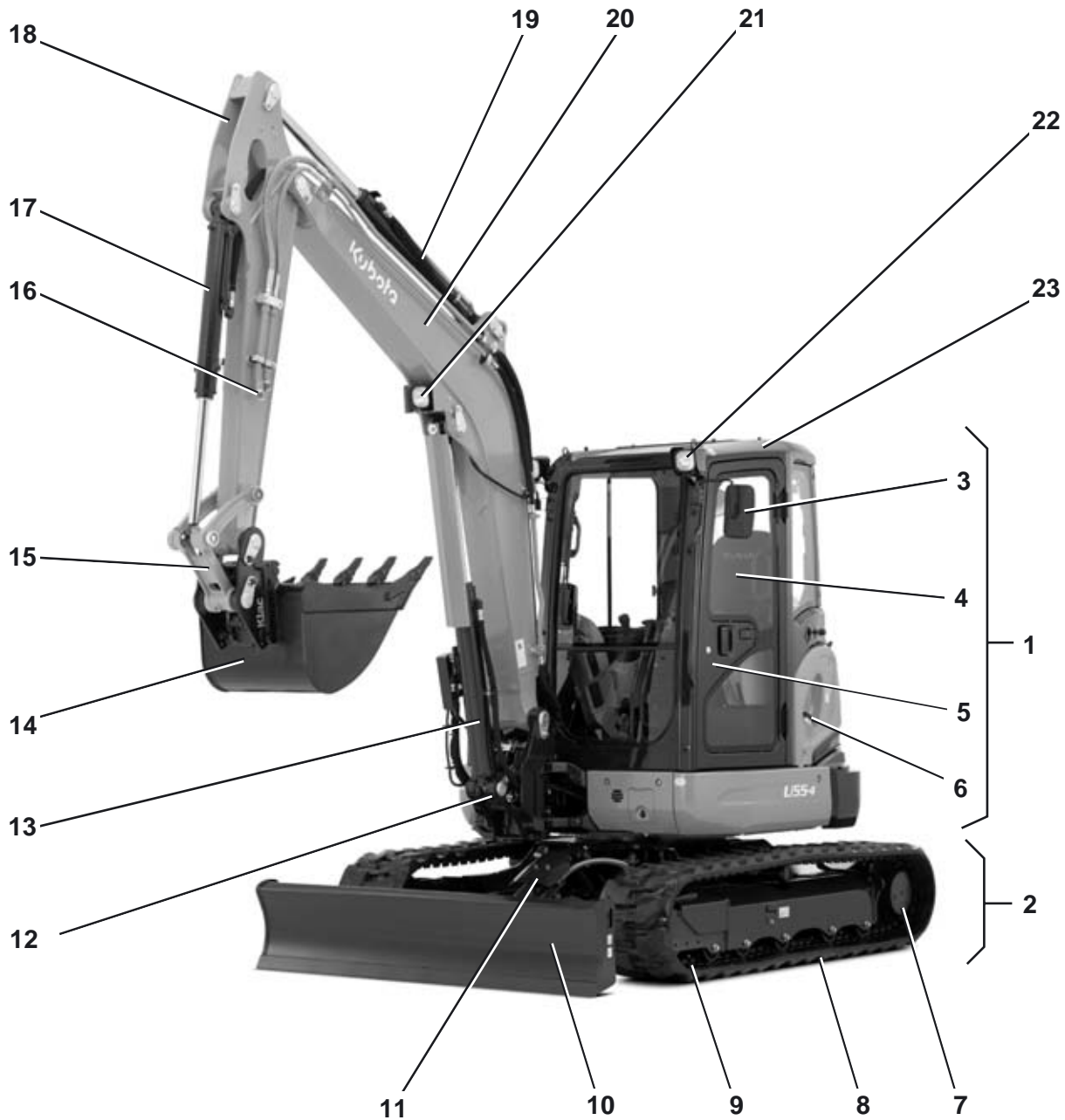

- | | |
|---------------------|-------------------------------|
| 1. Swivel frame | 13. Boom cylinder |
| 2. Track frame | 14. Bucket |
| 3. Rear view mirror | 15. Bucket linkage |
| 4. Operator's place | 16. Auxiliary port connectors |
| 5. Cab door | 17. Bucket cylinder |
| 6. tank filler neck | 18. Arm |
| 7. Drive sprocket | 19. Arm cylinder |
| 8. Crawler | 20. Boom |
| 9. Idler | 21. Working light (boom) |
| 10. Dozer | 22. Working lights (cab) |
| 11. Dozer cylinder | 23. Cab |
| 12. Swing block | |

Operator's place

The operator's place is located in the middle of the cab. It includes the following control elements:

1. Left control console
2. Drive levers and control pedals
3. Right control console
4. Operator's seat

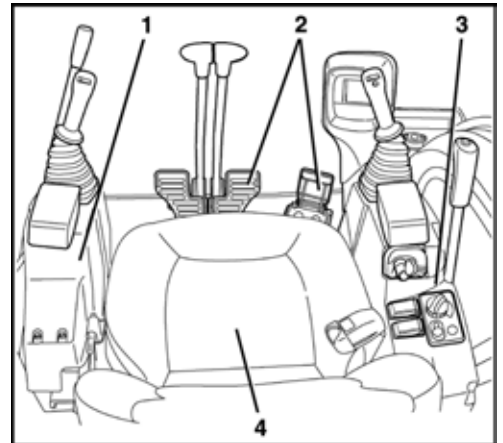

Left control console

The left control console includes the following components:

1. Control lever lock
2. Rocker switch for the auxiliary port 2
3. Wrist rest
4. Left control lever

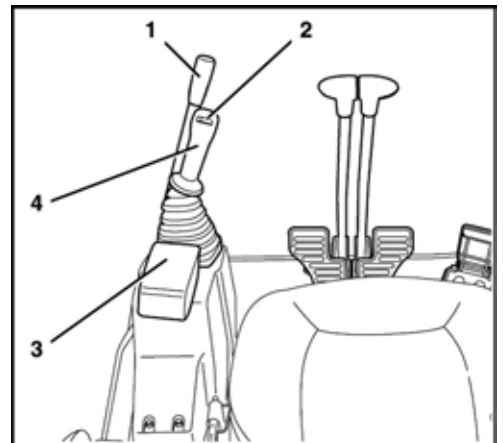

Description of the components of the left control console

- 1. Control lever lock**

To enter and leave the cab, the console must be raised by pulling up the control lever lock. The engine can only be started if the console is raised. The control levers, the drive levers, the boom swing pedal, and the dozer control lever are only operational when the console is lowered and the control lever lock is in the "down" position.
- 2. Rocker switch for the auxiliary port 2**

The rocker switch for auxiliary port 2 controls the oil flow to auxiliary port 2. When the left rocker switch is activated the oil flows to the connector on the left of the arm. Activating the right rocker switch results in the oil flowing to the right. Auxiliary port 2 can be controlled proportionally (stageless).
- 3. Wrist rest**

The wrist rest allows fatigue-free operation of the control lever.

4. Left control lever

The left control lever is used to move the swivel frame and the arm.

The figure, in conjunction with the following table, shows the functions of the left control lever.

Position of control lever	Movement
1	Arm crowd
2	Arm dump
3	Swivel frame to the left
4	Swivel frame to the right

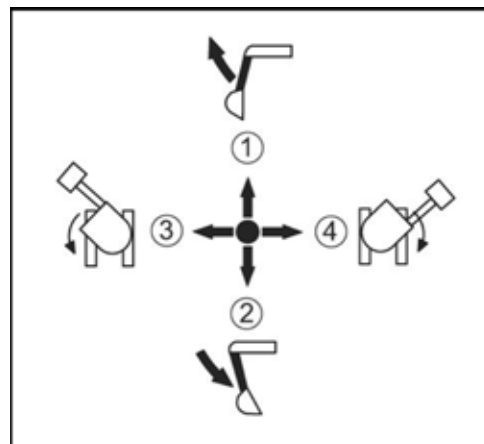

Drive levers and control pedals

Drive levers and control pedals include the following components:

1. Left and right drive levers
2. Boom swing pedal
3. Pedals for the left and right crawler

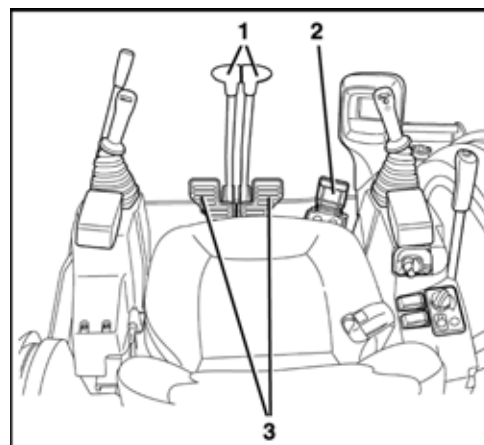

Drive levers and control pedals – description

1. Left and right drive levers

With the drive levers the excavator can be driven forwards and backwards and also turned. The left drive lever controls the left track and the right drive lever controls the right track.

2. Boom swing pedal

This pedal is used to swing the boom right and left.

3. Pedals for the left and right crawler

The pedals allow the operator to foot-control the drive levers.

Assembly and functions

Right control console

The right-hand control console contains the following components:

1. Rocker switch for the auxiliary port 1
2. One way hold switch
3. Travel speed button
4. Dozer control lever
5. Starter switch
6. Potentiometer for the adjustment of the engine speed
7. Heating and air-conditioner control (optional)
8. Wiper/washer switch
9. Engine stop knob
10. AUTO IDLE switch
11. Rotary beacon button
12. Working light button (cab)
13. Working light button (boom)
14. Wrist rest
15. Right control lever
16. Horn switch
17. Display and control unit

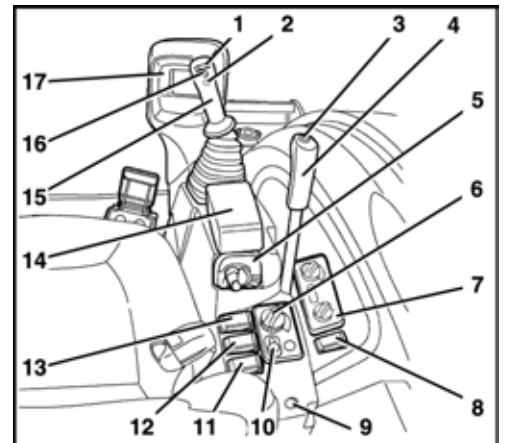

The display and control unit contains the following displays, switches, and indicators:

1. Menu button
2. Overload warning switch
3. Auxiliary port enable switch
4. Information button
5. Display selector switch
6. Display
7. Warning light
8. Engine oil pressure indicator
9. Charge indicator
10. Travel speed indicator

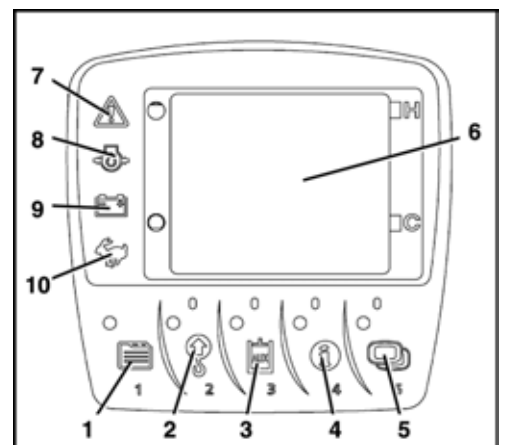

Description of the components of the right control console

1. Rocker switch for the auxiliary port 1

The rocker switch for auxiliary port 1 controls the oil flow to auxiliary port 1. When the left rocker switch is activated the oil flows to the connector on the left of the arm. Activating the right rocker switch results in the oil flowing to the right. Auxiliary port 1 can be controlled proportionally (stageless).

2. One way hold switch

Operating the one way hold switch results in a continuous oil flow to the auxiliary port connector to the left of the arm. When you operate it again, the oil flow discontinues. Thus, you can operate, for example, a breaker without having to continuously hold down the button.

3. Travel speed button

The travel speed button switches the travel speed mode on and off.

4. Dozer control lever

The dozer control lever is used to raise or lower the dozer. Pushing the lever forward lowers the dozer and pulling it back raises it.

5. Starter switch

The starter switch serves as the master switch for the entire machine and as switch for pre-glowing and starting the engine.

6. Potentiometer for the adjustment of the engine speed

The operator can use this potentiometer to set the engine RPM to any desired speed.

7. Heating and air-conditioner control (optional)

Operate the heater and the air-conditioner using the heating and air-conditioner control (optional).

8. Wiper/washer switch

The wiper/washer switch switches on the wiper for the front window and/or the washer system.

9. Engine stop knob

Using this device, the operator can switch off the engine manually.

10. AUTO IDLE switch

Using the switch you can switch the AUTO IDLE control on or off. The AUTO IDLE control makes sure that the engine speed pre-selected with the potentiometer drops down to idle speed after approx. 4 seconds - provided that no control is being used. Immediately upon activating a control, the engine speed will be immediately set to the pre-selected speed. When the AUTO IDLE control is activated the indicator inside the switch lights up.

11. Rotary beacon button

The rotary beacon (accessory) is switched on with this button.

12. Working light button (cab)

Switches the working lights in the cab on and off.

13. Working light button (boom)

Switches the boom working light on and off.

14. Wrist rest

The wrist rest allows fatigue-free operation of the control lever.

15. Right control lever

The right control lever is used to move the boom and the bucket.

The figure, in conjunction with the following table, shows the functions of the right control lever.

Position of control lever	Movement
1	Lower boom
2	Raise boom
3	Bucket crowd
4	Bucket dump

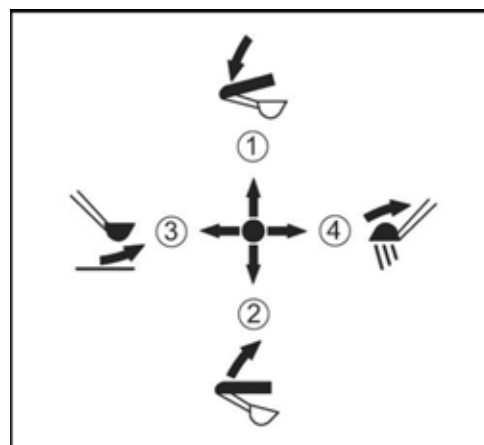

16. Horn switch

Depressing the horn switch activates the horn.

17. Display and control unit

The functions of the display and control unit are described in the "Display and control unit - description" section (page 49).

Display and control unit - description



The display and control unit's switches are multifunctional and are also used to navigate the display menu. You will find detailed descriptions of the individual functions in the respective chapters.

1. **Menu button**
The menu button activates the navigation function for the display menu.
2. **Overload warning switch**
The overload warning switch activates the overload warning function.
3. **Auxiliary port enable switch**
The auxiliary port enable switch activates the auxiliary port function.
4. **Information button**
The information button enables you to view additional system information in the display.
5. **Display selector switch**
The display selector switch changes what is shown in the display.
6. **Display**
The display shows operating states, warning and indicator symbols as well as system information.
7. **Warning light**
The warning light flashes red when a system fault or technical malfunction occurs. The warning light flashes yellow when the system issues a warning.



Operations must cease immediately when the warning light flashes red.

8. **Engine oil pressure indicator**
The engine oil pressure indicator lights up when the oil pressure is below the reference value.
9. **Charge indicator**
The charge indicator lights up when the charging circuit voltage is too low.
10. **Travel speed indicator**
The travel speed indicator lights up when the travel speed mode is activated.

Other equipment to be found at the machine

Other equipment located at and around the machine is described below.

Wiper/washer system

The front window is provided with a wiper/washer system. The system is operated with the wiper/washer switch (1).

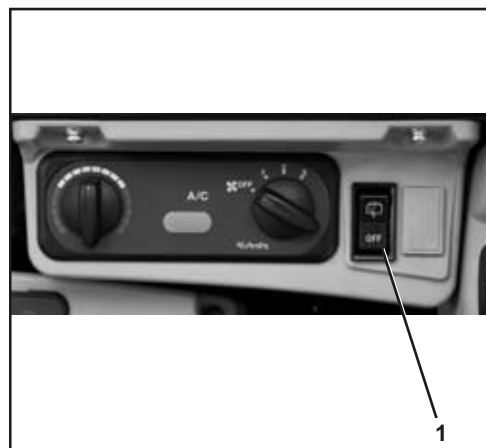

Interior lighting

An interior light (1) is located on the left side of the cab roof. It is turned on and off with the switch (2).

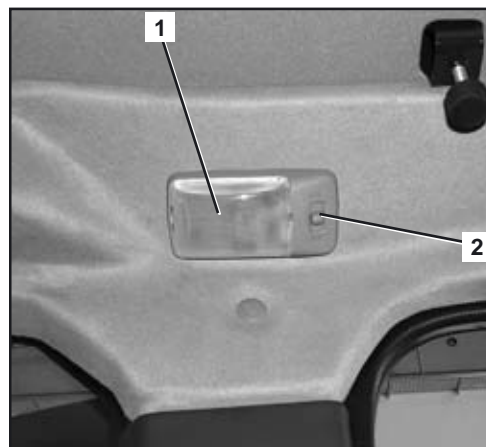

Fuse box

The fuse box (1) is located below the operator's seat behind a cover.

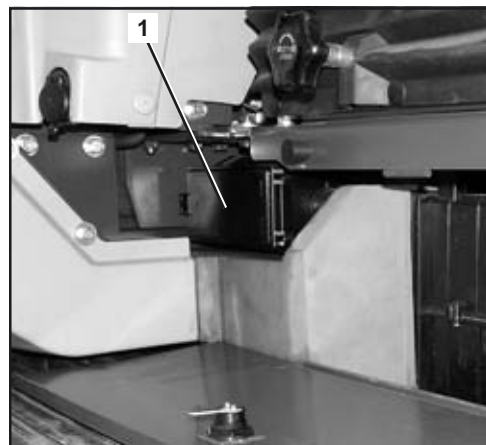

Assembly and functions

Tool compartment (KX057-4)

The tool compartment (1) is located on the right-hand side of the vehicle before the side cover.

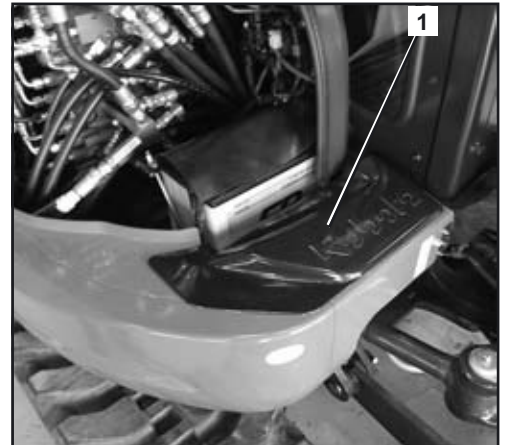

Tool compartment (U48-4 and U55-4)

The tool compartment (1) is located on the right-hand side of the vehicle under the side cover.

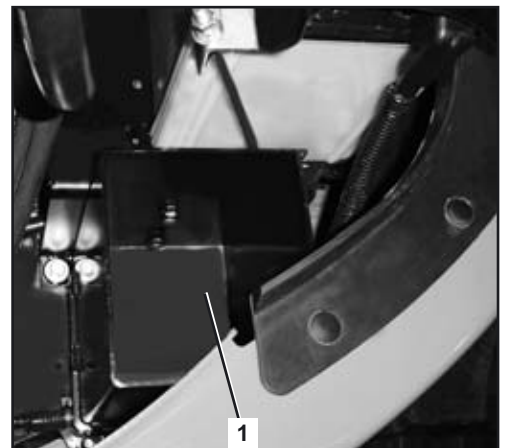

Main battery

The main battery (1) is located on the right side of the vehicle under the side cover.

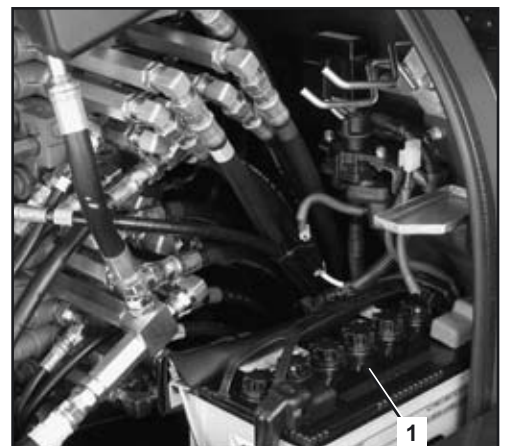

Battery cut-off switch

The battery cut-off switch (1) can be used to cut off the main power circuit. The battery cut-off switch is on the right vehicle side under the side cover.

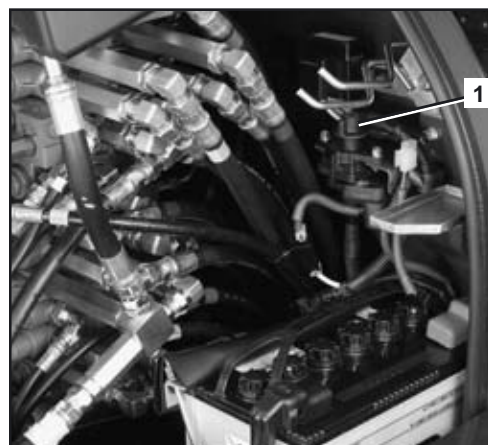

Cup holder

There is a cup holder (1) in the right control console.

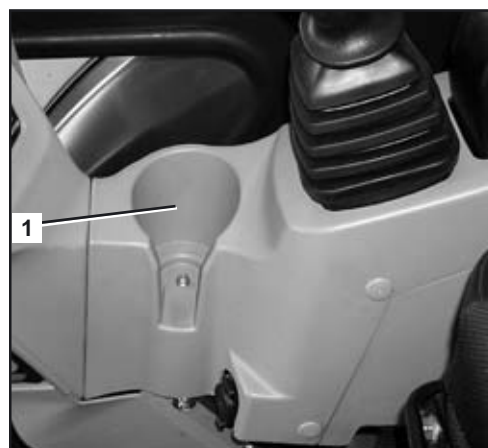

Tank filler neck and fill level monitor

The tank filler neck (1) is located at rear left-hand side (not if optional suction pump is equipped, page 53) and it closed with a lockable filler cap (2).

The fill level monitor (3) is located above of the tank filler neck and it indicates the fuel level when refuelling.

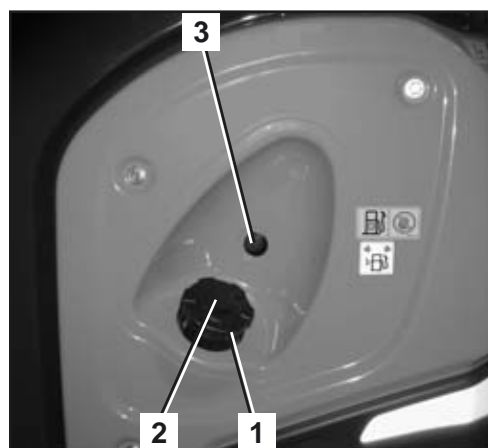

Assembly and functions

Tank filler neck and fill level monitor with suction pump (optional only KX057-4)

The excavator can be equipped with an optional suction pump (2).

With this equipment, the suction pump, the tank filler neck (3) and the fill level monitor (1) are located below the left service cover (4) (only if equipped with optional suction pump).

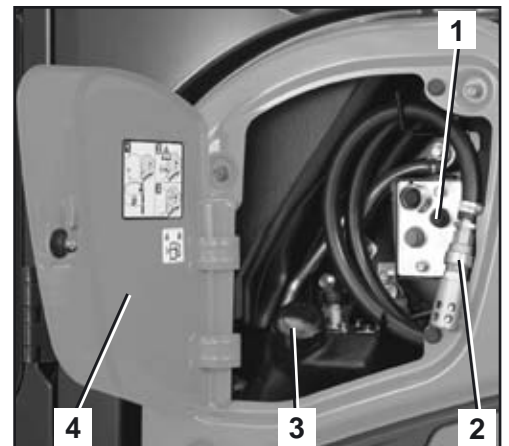

Rear view mirror

The rear view mirror (1) allows visibility down towards the rear of the excavator. The front rear view mirrors (2) allows visibility to the rear. The rear view mirrors can be adjusted for optimum visibility of the respective areas.



Heating and air-conditioning system (optional)

The heating controls are on the right control console. The control panel includes the following components:

1. Temperature control
2. Blower switch
3. Air-conditioner switch (optional)
4. Indicator (optional)

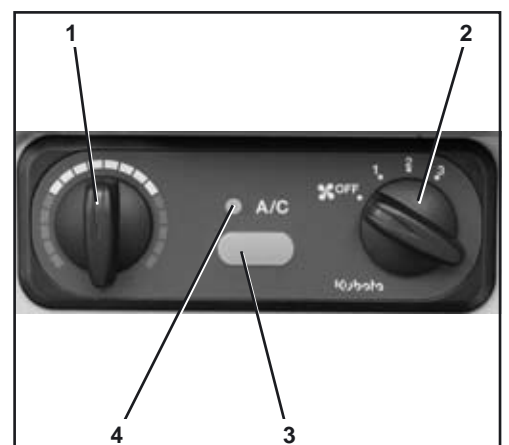

Using the air-conditioner switch, you can switch on the air-conditioner when the starter switch is in the RUN position and the fan is switched on. Operation of the air-conditioner system (optional) is indicated by the indicator.

Using the temperature control, you can set the air temperature to the desired value.

Using the blower switch, you can control the air flow in three stages, with stage 3 having the maximum air flow.

The air is drawn in through the cabin filter (1) as fresh air via the air intake to the right of the cabin (3) or as recirculated air in the cabin.

With the lever (21) the air intake can be switched between recirculated air (A) and fresh air (B).



To make sure the air gets sucked in properly from the cab, do not obstruct the interior air filter with objects (such as bags or clothes).

The air is conducted via the heat exchanger and/or the evaporator of the air-conditioner assembly (optional) to the air nozzles.

- A → Windshield
- B → Operator
- C → Leg room
- D → Side window
- E → Rear window

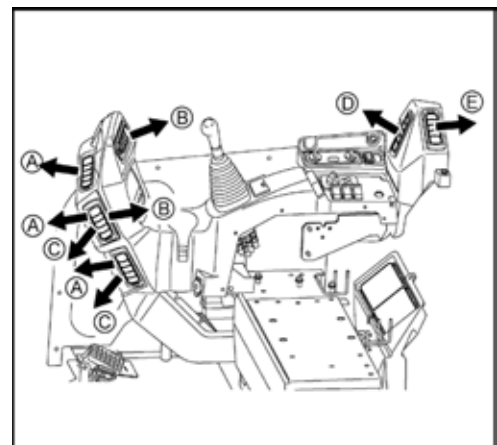

Engine compartment

The engine compartment (figure below) is positioned at the rear of the swivel frame; it is covered by a lockable hinged cover.

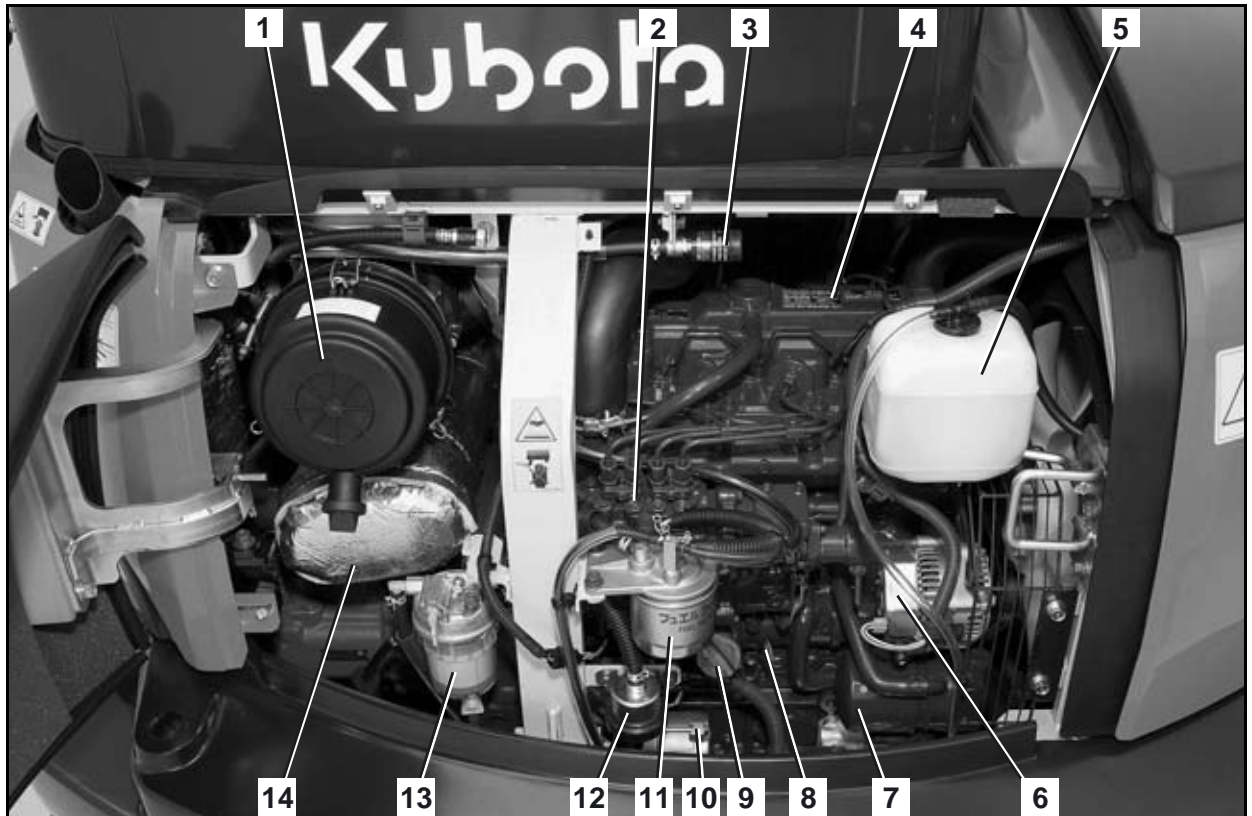

- | | |
|--------------------------------|-----------------------|
| 1. Air filter | 8. Oil dipstick |
| 2. Fuel injection pump | 9. Oil filler opening |
| 3. Filter indicator | 10. Starter |
| 4. Engine | 11. Fuel filter |
| 5. Coolant expansion reservoir | 12. Fuel pump |
| 6. Alternator | 13. Water separator |
| 7. Oil filter | 14. Muffler |

Hydraulic system

All controls enable the functions via a hydraulic oil pilot control circuit.

The accumulator allows the boom and the arm to be lowered in case of an engine failure.

The hydraulic oil tank contains the suction filter and the return filter.

Using the return change valve for the auxiliary port you can activate a direct return flow to the hydraulic oil tank while auxiliary port 1 is in operation. The direct return flow enables you to use one way hydraulic attachments.

1. Plug
2. Return change valve for direct return flow
3. Control valve
4. Hydraulic oil tank
5. Sight glass for hydraulic oil level
6. Pilot circuit filter

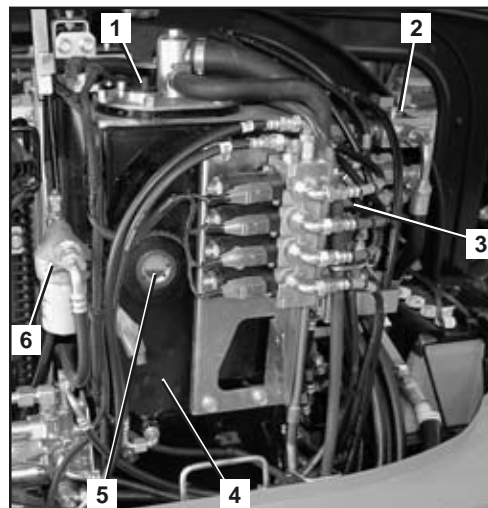

Radiator and condenser

The radiator and condenser for the cooling circuits and the air-conditioner system are under the right side cover.

1. Coolant radiator
2. Fuel cooler
3. Hydraulic oil radiator
4. Condenser (air-conditioner)
5. Liquid reservoir and dryer (air-conditioner)

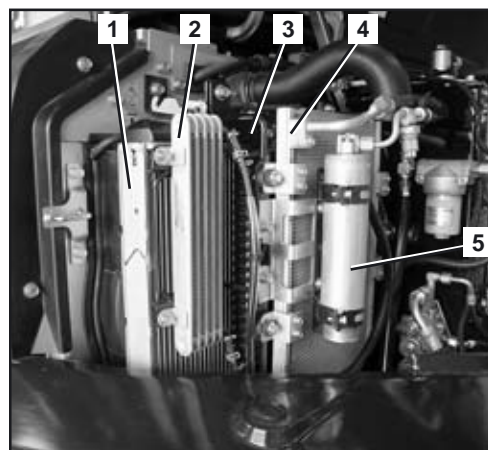

Operation

Safety rules for operation

- The safety instructions (page 14) must be followed.
- The excavator may only be operated according to its approved use (page 16).
- The excavator may only be operated by trained personnel (page 12).
- Do not operate the excavator when under the influence of drugs, medication or alcohol. Stop operation when getting tired. The operator must be physically capable of operating the excavator safely.
- The excavator should only be operated if all protective devices are fully operational.
- Before starting or working with the excavator, make sure that there is no danger for any person nearby.
- Before starting the excavator, it must be checked for external damage and operability, and the pre-start checks must be carried out. If defects are detected, the excavator should only be taken into operation after the defects have been repaired.
- Wear tightly fitting working clothes in accordance with the trade association regulations.
- During the operation of the excavator, nobody except the operator is allowed to be inside the cab or get on the excavator.
- For getting on and off, the swivel frame should be positioned in an angle which allows the operator to use the crawler or the step (if applicable) to enter the cab.
- Always stop the engine when leaving the cab. In exceptional cases, e.g. for troubleshooting, the cab can also be left with the engine running. The operator must make sure that the left control console remains in an upright position. The controls may only be used while the operator is sitting on the operator's seat.
- During operation, it is forbidden to stretch any part of the body out of the window or cab door, such as arms, legs, or the body.
- If the operator leaves the excavator (e.g. for breaks or at the end of work), the engine must be stopped and the excavator must be secured against restarting by removing the key. The cab door must be locked. Before leaving the excavator, park the machine so that it can not move.
- Whenever work is interrupted, the bucket must always be lowered to the ground.
- Do not allow the engine to run indoors, unless the room is equipped with an exhaust gas extraction system or otherwise well ventilated. The exhaust gas contains carbon monoxide, a colourless, odourless, and lethal gas.
- Never crawl under the excavator before the engine is stopped, the key is removed and the excavator is secured against moving.
- Never crawl under the excavator if it is only raised with the bucket or the dozer. Always use suitable supports.

Guiding the operator

- If the operator's working and driving area is obscured, the operator must be supported by a guide.
- The guide must be capable of performing this kind of work.
- Before starting work, the guide and the operator must agree the necessary signals.
- The guide's position must be clearly visible by the operator.
- The operator must stop the excavator immediately if the eye contact to the guide is interrupted.
→ As a rule, either the excavator or the guide may move, never both at once!

Working in the vicinity of overhead power lines

When working with the excavator in the vicinity of overhead power lines and tram lines, a minimum distance as specified in the following table must be maintained between the excavator and its attachments and the power line.

	Rated voltage [V]	Safe distance [m]
	up to 1 kV	1.0 m
over 1 kV	up to 110 kV	3.0 m
over 110 kV	up to 220 kV	4.0 m
over 220 kV	up to 380 kV or when rated voltage is unknown	5.0 m

If safe distances can not be maintained, the power lines must be switched off in coordination with their owner or provider and secured against making them live again.

When approaching overhead power lines, any possible movements of the excavator must be taken into consideration.

Unevenness of the ground or sloping the excavator can reduce the safe distance.

Wind can cause the overhead power lines to sway, thus reducing the safe distance.

In case of a power cross-over, leave the danger zone with the excavator, if possible, by taking suitable measures. If this is not possible, do not leave the operator's place, warn any approaching persons of the danger, and have the power switched off.

Working in the vicinity of underground power lines

Before starting with excavation work, the owner of the excavator or the person responsible for the work must check if there are any underground power lines in the proposed working area.

If there are underground power lines present, the position and routing of the power lines must be determined together with the owners or operators and the required safety measures must be determined.

If power lines are encountered or accidentally damaged, the operator must stop working immediately and inform the responsible person.

Initial operation

Before initial operation, the excavator must first be checked visually for external transit damages and checked if the shipped equipment is complete as ordered.

- Check fluid levels as described in the "Maintenance" section (page 124).
- For a description of all operation features refer to the "Operating the excavator" section (page 62) as well as the following sections.

If defects are detected, please inform your dealer immediately.

Setting the display language

Messages in the display can be shown in 11 languages.

- Turn the starter switch to the RUN position.
- Press button 1.

The user menu appears in the display.

- Press button 2 or 3 until "Language Selection" is selected in the display.
- Press button 5 to confirm.



The list of available languages appears in the display.

- Press button 2 or 3 until the desired language is selected.
- Press button 5 to confirm.



Setting the time

- Turn the starter switch to the RUN position.
- Press button 1.

The user menu appears in the display.

- Press button 2 or 3 until "Clock Set" is selected in the display.
- Press button 5 to confirm.

Date and time appear in the display.

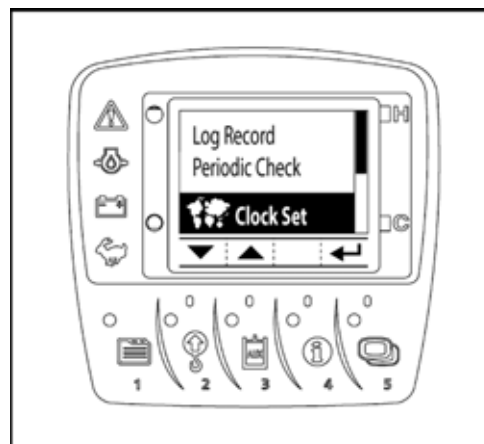

Press button 4 to switch between the units of time: year, month, day, hours and minutes.

- Press button 4 until the desired unit of time is selected.
- Press button 2 to decrease the numerical value.
- Press button 3 to increase the numerical value.
- Press button 5 to confirm.

 Press and hold button 2 or 3 down to change the numerical value fast.

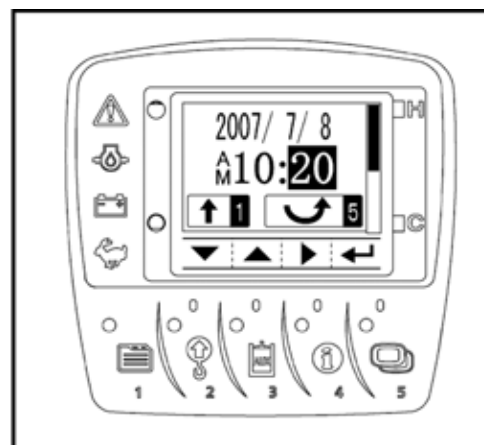

- To complete setting the clock and save your values, press button 5 again.

The message "Clock Set" appears in the display.

 Input can be cancelled at any time. Changes are then not saved.

- To cancel your input, press button 1.

The display returns to its previous display mode.

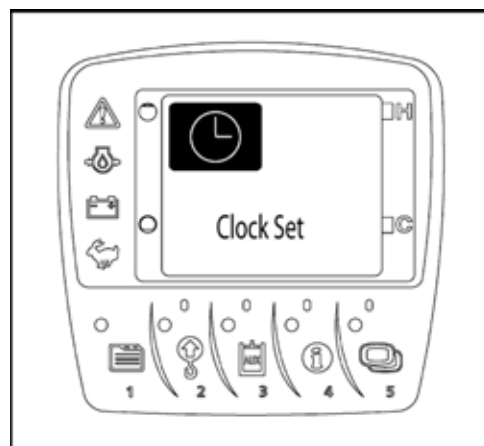

Operation

Date and time display format

Time can be displayed in the 12- or 24-hour format, while the date format can be changed to day, month, year.

- Turn the starter switch to the RUN position.
- Press button 1.

The user menu appears in the display.

- Press button 2 or 3 until "Various Settings" is selected in the display.
- Press button 5 to confirm.



- Press button 2 or 3 until "Date/Clock Set" is selected in the display.
- Press button 5 to confirm.

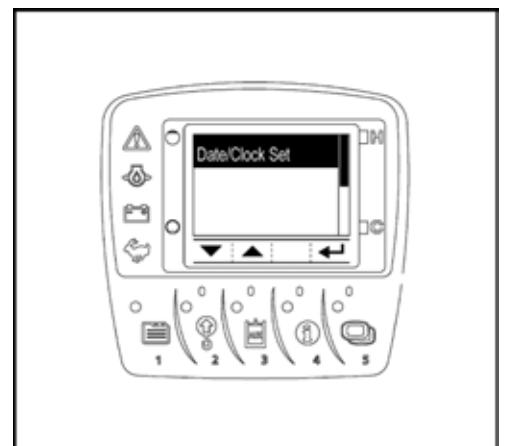

Date and time appear in the display.

- Press button 2 or 3 to switch between the display formats of the date (area A).
- Press button 5 to confirm.

Press button 4 to switch between the display formats of the time.

- Press button 2 or 3 to switch between the display formats of the time (area B).
- Press button 5 to confirm.

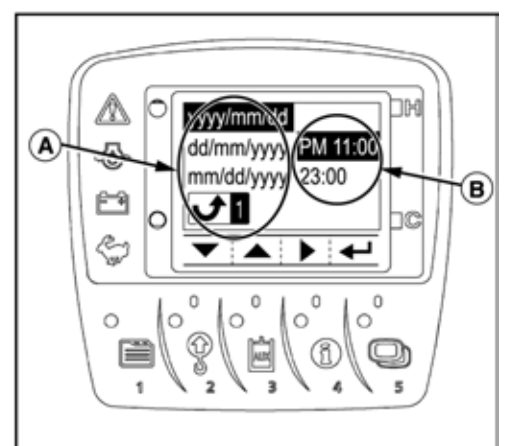

Input can be cancelled at any time. Changes are then not saved.

- To cancel your input, press button 1.

The display returns to its previous display mode.

Running-in of the excavator

During the first 50 hours of operation, the following points should be adhered to in all cases:

- Warm up the excavator at an average engine speed and with a low load; do not let it warm up at idling position.
- Do not overload the excavator.

Special maintenance instructions

- Change the oil in the final drives after the first 50 service hours.

Operating the excavator

For a safe excavator operation, see the following sections.

Pre-operational services



For the performance of the services, the excavator must be parked on level ground and the key must be removed.

- Open the side cover (page 111). Always close the side cover after the work is done.
- Open the engine compartment cover (page 110).

Walk-around inspection

- Check the excavator for visible damage, loose nuts and screws and leaks.
- Check the pipe safety valves. Do not carry out any excavating work if a pipe safety valve is damaged.

Checking the engine oil level

- Pull out the oil dipstick (1) and wipe it with a clean cloth.
- Insert the oil dipstick completely and pull it out again. The oil level should be in the "A" area. If the oil level is too low, add engine oil (page 134).



When the oil level is too high or too low, the engine might get damaged during operation.

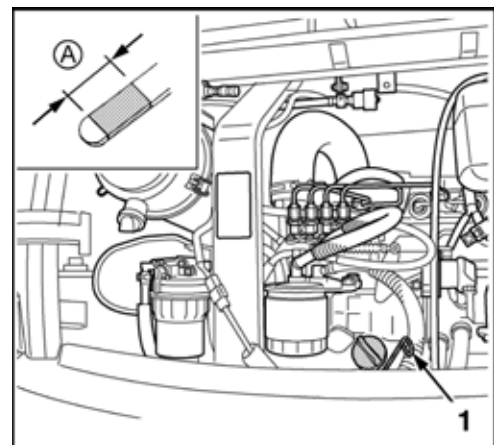

Operation

Checking the coolant level

- Check the coolant level in the expansion reservoir (1). The fluid level must be between FULL and LOW.



Do not open the radiator cap.



If the coolant level is below the LOW mark, refill coolant (page 129).

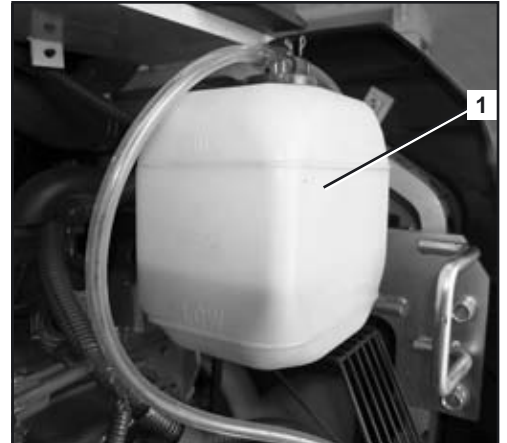

If the coolant level is below the LOW mark a short time after adding coolant, the cooling system is leaky. The excavator may only be started again after the fault is repaired.

Checking the radiators and the condenser

- Make a visual inspection of the coolant radiator (1), fuel cooler (2), hydraulic oil cooler (3) and condenser (4) for leaks and accumulation of dirt and debris.

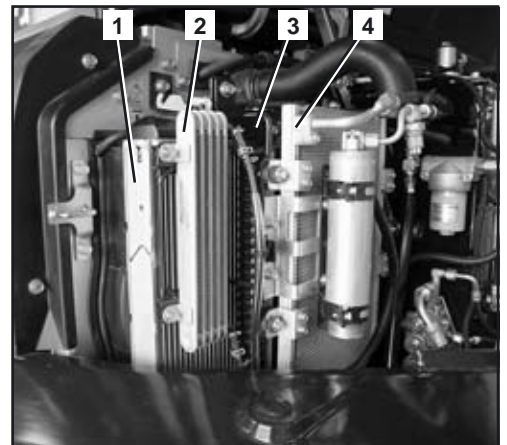

- If there is mud or debris at the radiators or the condenser, clean the radiators and condenser (page 130).

Checking the V-belts



*The engine must be switched off and the key removed!
Do not attempt to grasp rotating or moving parts.*

- Press in the V-belt (1) at position "A"; the belt must give way for 7 to 9 mm (at a pressure of 6 to 7 kg). Adjust the V-belts if necessary (page 131).
- Press in the V-belt (2) at position "B"; the belt must give way for 12 to 15 mm (pressure of 7 kg). Adjust the V-belts if necessary (page 131).
- Check both V-belts for wear and tear. Replace the V-belts if necessary (page 131).

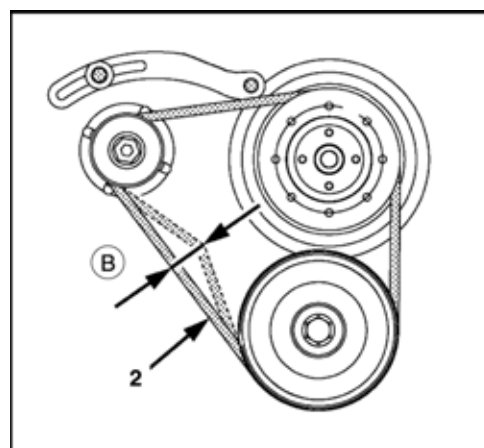
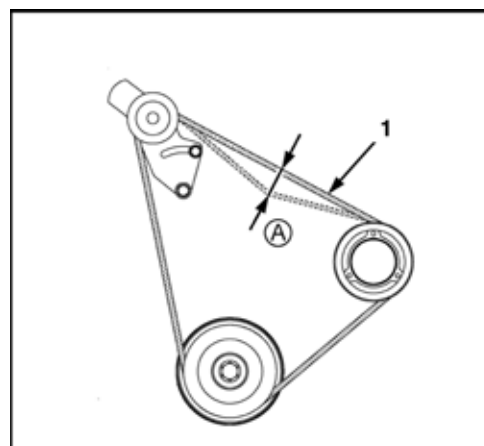

Checking the exhaust system for leaks

- Check the exhaust system for leaks and security (formation of cracks).



If the inspection is carried out when the engine is warm, there is a risk of burns at the exhaust system.

- If the exhaust system is leaky or loose, the excavator may only be taken into operation after the defects are eliminated.

Checking the oil level of the hydraulic system



Operate the boom, arm, bucket and boom swing mechanism so that all hydraulic cylinders are extended half way. Lower the dozer onto the ground. See the "Placing out of operation" section (page 95).



Check the oil level in the sight glass (1). The oil level should be half way up the sight glass. Carefully check the position of the hydraulic cylinders before topping up the oil. For more information see the "Topping up/changing the hydraulic oil" section (page 142).

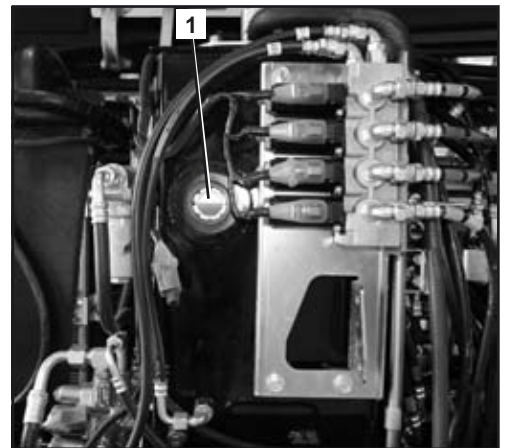

Greasing the bucket bolts and bucket linkage bolts

- Start the engine (page 69).
- Position the arm and bucket as shown in the figure. See the "Operating the controls during excavation work" section (page 78).
- Stop the engine (page 70).
- Lubricate all greasing points (see figure to the right) – see the "Recommended lubricants" section (page 157) – by injecting grease until fresh grease emerges.



Wipe emerged grease off immediately and store dirty cleaning cloths in the containers provided for disposal.

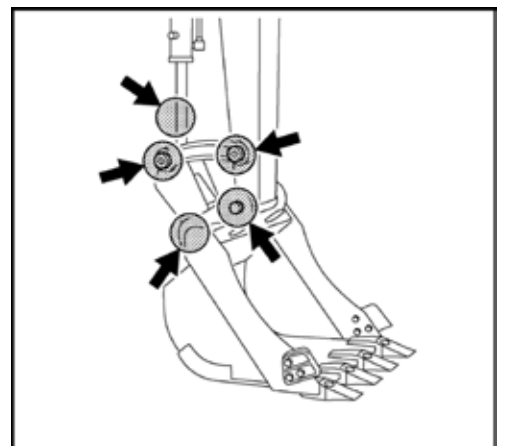

Checking the electric cables and connections

- Check all accessible electric cables, connectors and connections for condition and security.
- Repair or replace damaged parts.
- Check the fuse box and fuse holders for oxidation and dirt, clean if necessary.

Checking fuel level, coolant temperature and time



The following function can be carried out when the key is not in the starter switch.

- Press the menu button (button 1) or the display selector switch (button 5).

The display shows the fuel level (1), the time (3) and the coolant temperature (2) for approx. 10 seconds.

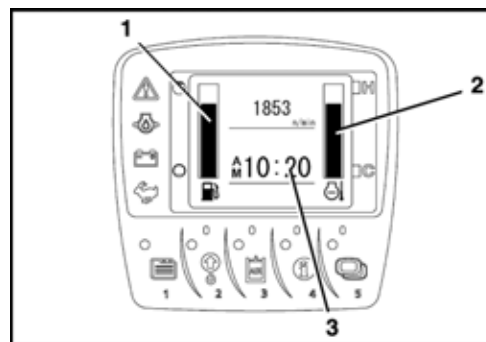

Setting up the workplace

Please refer to the "Opening and closing the cab door" section (page 99).

Getting on the excavator

- Move the left control console (2) up as far as possible by pulling the control lever lock (1) up.



The control console must remain in this position until the engine is started, as the engine can only be started in this position.

- Get on the excavator by using the crawler or step as a stepping aid.
- Sit down on the operator's seat.

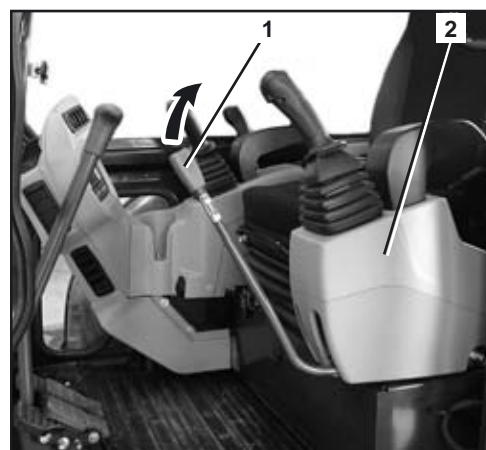

Adjusting the operator's seat



Adjust the operator's seat so that fatigue-free and comfortable working is possible. It should be possible to operate all controls safely.

Horizontal seat adjustment (seat stand-off)

- Pull the horizontal seat adjustment lever (4) up and move the seat to the desired position by moving it forward or back, then release the lever.



Check that the seat is locked into place.



Seat height adjustment (knee height)

The seat height can be adjusted to three stop positions. To adjust the seat height, slowly raise the seat until it automatically engages in the next stop. When the seat is raised over the highest stop, it will be lowered automatically to the lowest position again.



Adjust the seat height in relation to its horizontal position so that the foot controls can be operated safely.

- To raise: Raise the seat to the desired position and engage it.
- To lower: Raise the seat to the highest position, lower it fully and engage it.



Make sure that the seat adjuster is engaged.

Spring adjustment (operator's weight)

- The seat can be set to the weight of the operator with the rotary knob (figure above, position 3).
- Turning the grip clockwise increases spring tension (heavier operator), turning the grip anticlockwise reduces spring tension (lighter operator).
- Adjust the seat so that a comfortable cushioning is achieved.

Backrest adjustment

- Take the load off the backrest and pull the backrest adjustment lever (figure above, position 2). Set the backrest to the desired sitting position and release the lever. The backrest should be adjusted so that the operator can safely operate the control levers with the back resting completely on the backrest.

Seat belt

- Buckle up (figure above/1).
- Check that the seat belt is fastened tightly.



Do not operate the excavator without the seat belt fastened.

Rear view mirrors adjustment

- Check the adjustment of the rear view mirrors. If necessary, adjust the mirrors until the optimum sight is ensured.

Safety instructions for starting the engine



The excavator is equipped with an anti-theft system (page 113).



When starting the excavator for the first time on a work day, carry out the pre-operational services (page 62).



Make sure that there are no persons within the excavator's working area. It is essential to warn persons in the vicinity of the excavator by briefly honking the horn.



Make sure that all operational controls are in the neutral position.



Starting the excavator is only allowed when the operator is sitting on the operator's seat.



Before starting the engine, make the necessary operator station adjustments (page 66).





If the engine does not start immediately, cease the starting procedure. Wait a short time before re-attempting a start. If the engine does not start after several attempts, contact skilled personnel. If the battery is discharged, jump-start the excavator (page 103).



Do not use Start Pilot or similar substances as a starting aid.

Operation

Starting the engine

- Place the potentiometer (1) to the centre position between  and . The AUTO IDLE switch (2) is switched off. The indicator does not light up.
- Insert the key into the starter switch (3) and turn it to the RUN position.

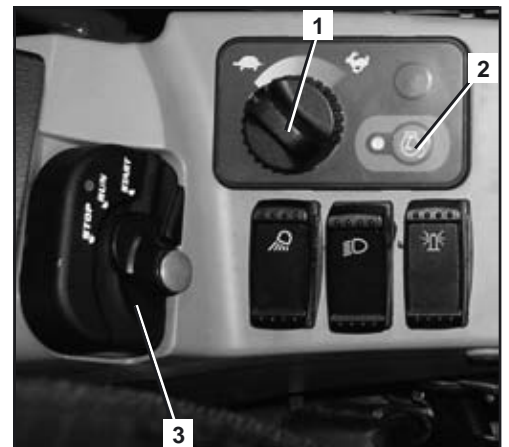

The excavator is equipped with an anti-theft system. If someone tries to start the excavator with the wrong key, the display message as in the figure on the right appears.



If the bunch of keys contains metal parts, such as key rings or other keys, the engine might fail to start.



If the control lever lock is not raised, the display message as in the figure on the right appears.

The preglowing indicator (1) lights up for a short period of time. The engine can be started after it goes off.

The engine oil pressure indicator (3) lights up, then goes out again after the engine has started.

The charge indicator (2) lights up, then goes out again after the engine has started.

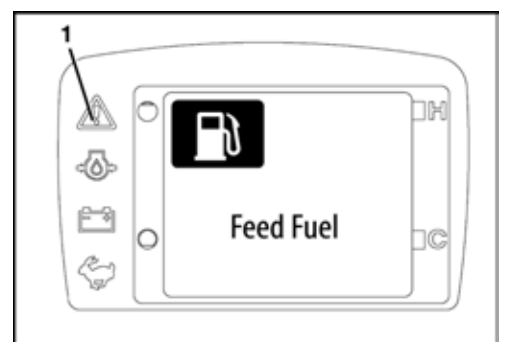
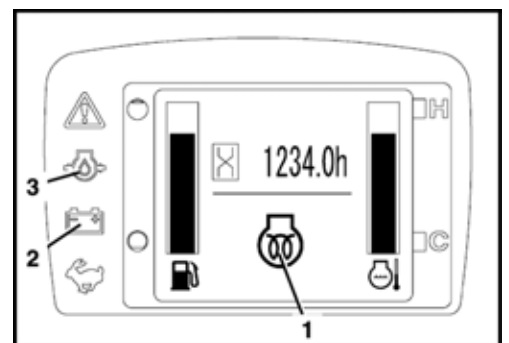

If the indicators do not light up when the starter switch is in the RUN position, remove the key and contact suitably qualified personnel.

If the message "Feed Fuel" appears in the display and the warning light (1) flashes yellow, there is very little fuel left in the tank. Refuel the excavator (page 105).



- Turn the starter switch to the START position and hold it there until the engine has started. Release the starter switch.
- Lower the left control console and make sure that the control lever lock engages.
- Let the engine run at middle speed until the operating temperature has been reached.

After the engine has reached its operating temperature, set the engine speed required for operation:

- Move the potentiometer towards  or  until the engine reaches the required speed. Then switch on the AUTO IDLE control. The AUTO IDLE control makes sure that the pre-selected engine speed drops down to idle speed after approx. 4 seconds – provided that no control lever is being used.

Using the display selector switch (button 5) you can switch between numeric and graphic displays of the engine speed and the hours of operation.

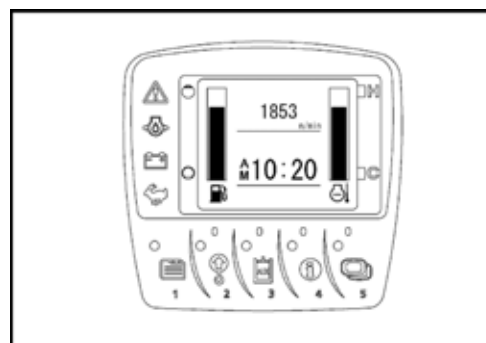

Both the numeric (1) and the graphic (2) displays of the engine speed show the engine's current number of revolutions per minute.

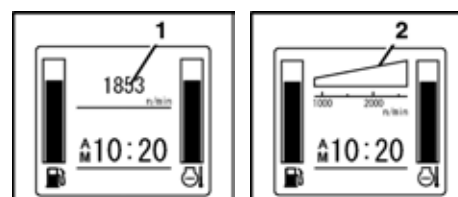

The time meter (3) shows the actual hours of operation of the excavator (independent from the engine speed).

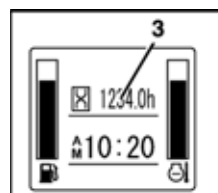

When the hydraulic oil is cold (i.e. in cold-weather conditions), the AUTO IDLE control may experience problems during the warm-up phase. This does not constitute a defect.

Check the displays and indicators during operation (page 71).

Stopping the engine



If the engine is to be stopped to take the excavator out of operation, the services for placing the excavator out of operation (page 95) must be carried out.

- Turn the starter switch to the STOP position and remove the key.

Observation of the displays after starting and during operation

The operator must observe the display indicators and displays after starting and during operation.



The warning light (1) flashes red when a system fault or technical malfunction occurs. Stop the engine immediately! The warning light flashes yellow when the system issues a warning. In addition to the messages that appear in the display, you will also hear an acoustic warning signal.



Clear the messages by taking appropriate steps, see "Troubleshooting: Display indications" (page 119), or contact qualified personnel if necessary.

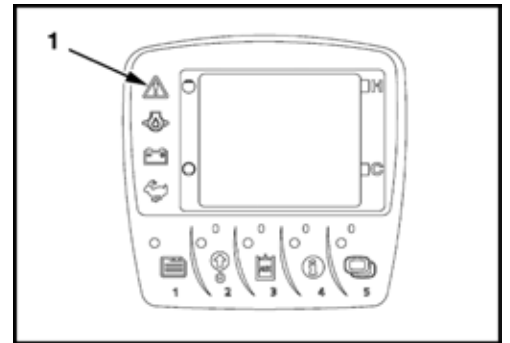

If the engine oil pressure becomes too low during operation, the engine must be stopped immediately. The engine oil pressure indicator (2) lights up, the warning light (1) flashes red and the display message as in the figure on the right appears.

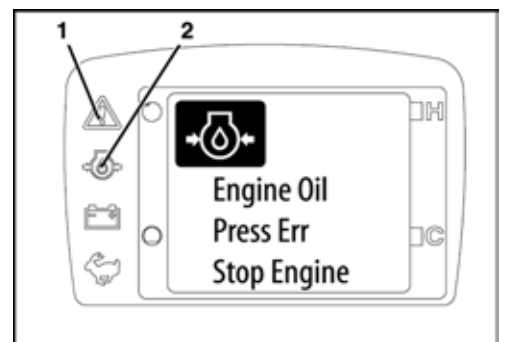

If a fault occurs in the charging system during operation, the engine must be stopped immediately. The charge indicator (2) lights up, the warning light (1) flashes red and the display message as in the figure on the right appears.

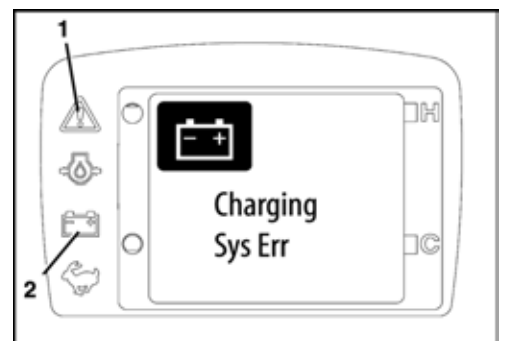

When the machine is being operated at or close to full capacity, the temperature of the coolant can rise a little higher than normal. The display message as in the figure on the right appears.

The message disappears shortly, but the coolant temperature gauge flashes as long as the temperature is higher than normal.

Operate the machine only with reduced loads until the operating temperature is normal again.

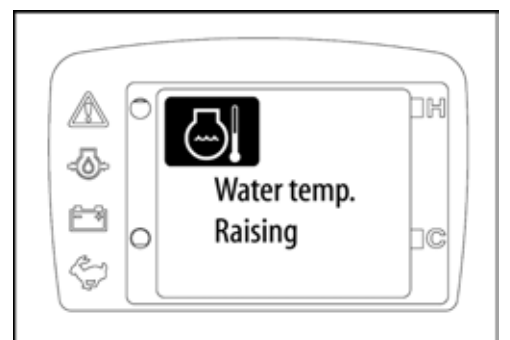

If the coolant temperature is too high, cool down the engine by changing into idle. The display message as in the figure on the right appears.



Allow the machine to idle for five minutes before switching off the engine!

- Check the level of the coolant in the expansion tank.



Do not open the radiator cap → risk of scalding.

- If the water level is below the "LOW" mark, let the engine cool completely and add coolant (page 129).
- Check the cooling system for leaks; if necessary, contact skilled personnel.
- Check if the V-belt is very loose or broken; if necessary, contact skilled personnel.
- Check if the air intake in the right side panel, the radiator, and the condenser are very dirty. If necessary, clean the radiator (page 130).
- Watch the fuel gauge (1).



The bar indicates the amount of fuel remaining in the tank. The bar slowly becomes shorter as fuel is used up during operation.

When the fuel tank is full, the bar is at the top, and in addition, the display (2) is lit up.

When the fuel tank is empty, the bar is at the bottom, and in addition, the display (3) is lit up.



When the fuel tank is empty, the machine cannot be operated. The machine must be refuelled and the fuel system bled.

If the message "Feed Fuel" appears in the display and the warning light (1) flashes yellow, there is very little fuel left in the tank. Refuel the excavator (page 105).

The message disappears shortly, but the warning light flashes as long as the cause persists.



Press the information button (button 4) if you want to display the message for a current warning again.

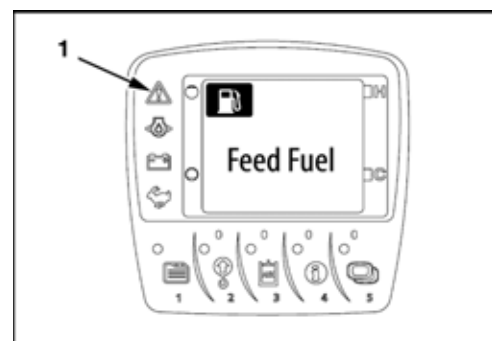
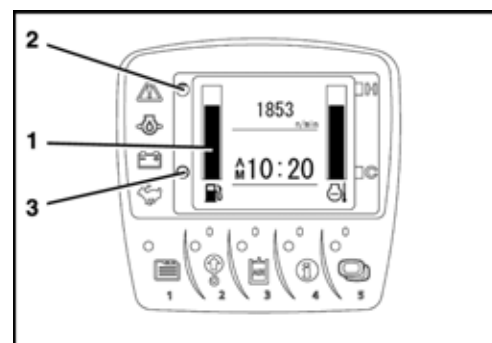
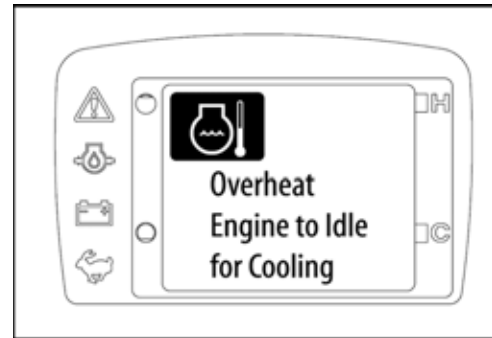

Operation

Also stop the engine immediately if

- the engine speed rises or drops suddenly,
- abnormal noises are heard,
- the excavating devices do not respond to the control lever as expected or
- the exhaust fumes are black or white. When the engine is still cold, white smoke for a short time is normal.

Driving the excavator

- Adhere to the general safety rules (page 14) and the safety rules for operation (page 57).
- Carry out the pre-operational services (page 62).
- Start the engine (page 69).
- Observe the displays and indicators (page 71).



Ensure that the boom and the dozer are in the direction of travel as shown in the figure.

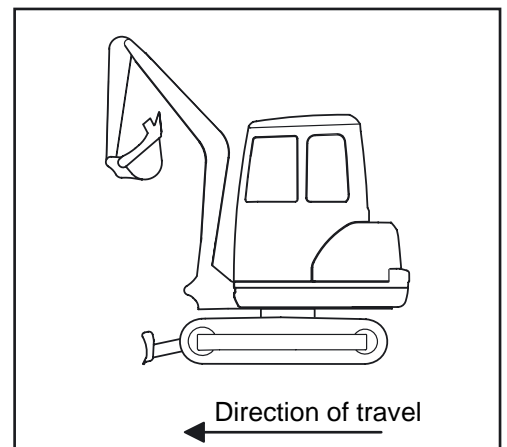

When driving with the excavator, always observe the following safety instructions.

When working on slopes, observe the tilt of the excavator (see figure).

Max. lateral sway → 27 % resp. 15°

Climbing performance → 36 % resp. 20°

- Keep the bucket as low as possible when driving.
- Check the ground for stability, and verify if there are holes or other potential obstacles.

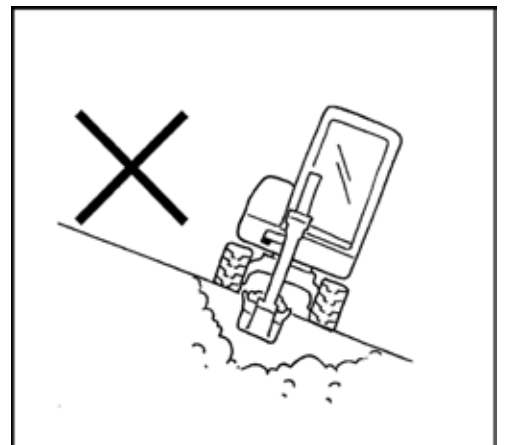

- Approach overhangs and edges of ditches carefully as they could cave in.
- Drive slowly downhill, do not allow the vehicle speed to increase uncontrollably.
- Close the cab door.
- When driving, the bucket should be approx. 200 to 400 mm (A) over the ground (see figure).

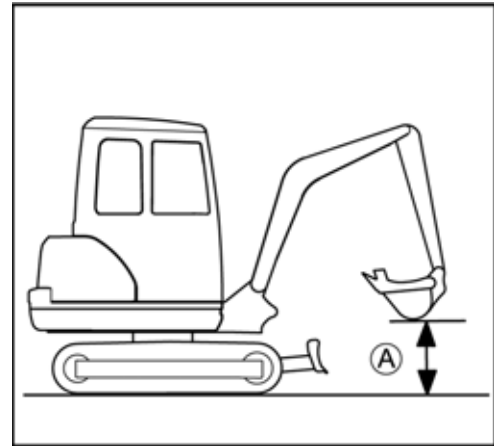

- Raise the dozer to the top position.
- Select an appropriate engine speed.

Driving

- Push both drive levers forward simultaneously to drive the excavator straight ahead. Releasing the drive levers stops the excavator immediately. To reverse the excavator, pull both drive levers back simultaneously.

- (A) Forward
- (B) Reverse
- (C) Straight ahead



If the dozer is not at the front, as shown in the figure, but at the rear, the operation of the drive levers is exactly opposite. Drive lever forwards:

→ The excavator backs up.

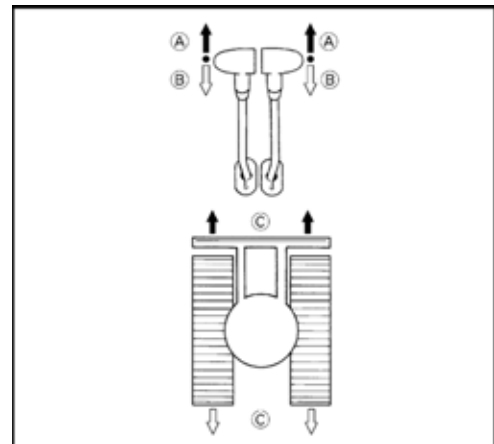

- To drive faster, press the travel speed button (1).



If the driving resistance increases when driving with travel speed (due to a slope or obstacle), the machine automatically switches to low speed. If the driving resistance decreases after a while, the machine switches automatically back to travel speed.

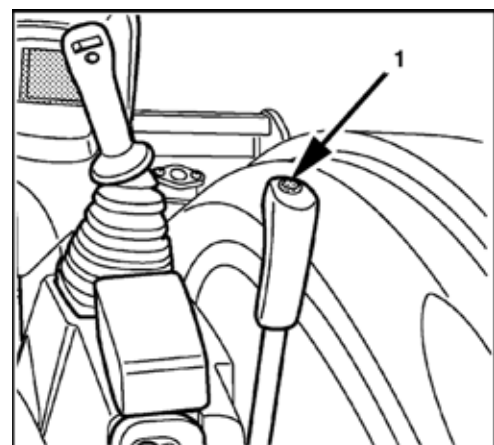

Operation

Two audible signals will sound and the indicator (1) will come up. Pressing the travel speed button again switches back to normal speed and only one signal will sound.

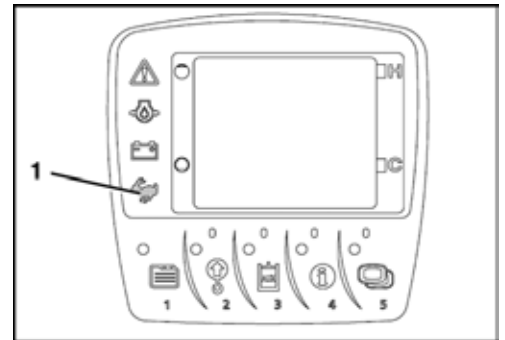

Do not drive fast on muddy or uneven terrain, also if another control is operated (e.g. turning the swivel frame).

Turning



Turns are described for the forward direction of travel with the dozer at the front. If the dozer is positioned at the rear, the steering movements should be in the opposite direction.



When making turns, be sure nobody is standing within the swing area of the excavator.

During driving

- Pull the left drive lever to neutral, leave the right drive lever pushed forward.

(A) The excavator makes a left turn.

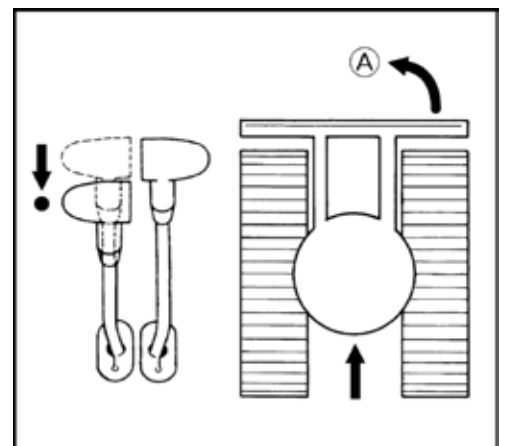

From a standing position

- Leave the right drive lever in neutral, push the left drive lever forward. In this case, the turning radius is determined by the right track.

(A) The excavator makes a right turn.

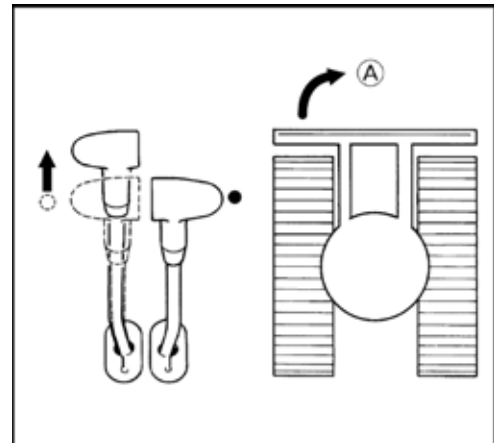

Turning on the spot



Do not make a turn on the spot with the travel speed button actuated.

- Move the drive levers in opposite directions. The tracks will turn in opposite directions. The centre of the vehicle is its vertical axis.

(A) Turning on the spot to the right.

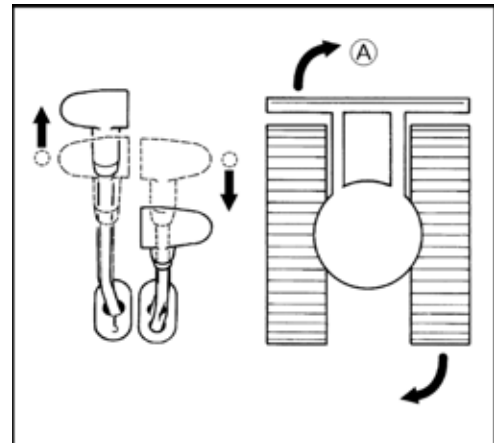

Operation

Driving uphill and downhill



Exercise extreme caution when driving up and down a slope. Do not use the travel speed button.

- When driving on gradients, raise the bucket approx. 200 to 400 mm (A) above the ground (see figure).
- When driving on gradients, let the bucket slide over the ground if the terrain allows it.

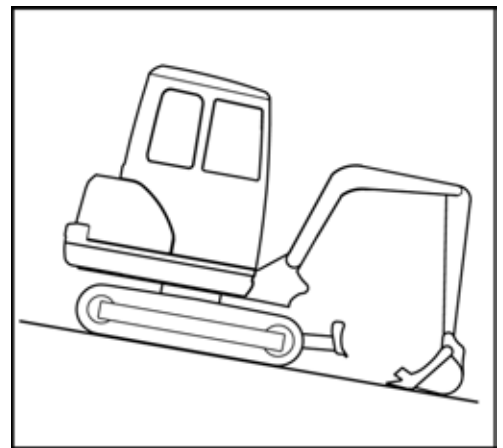
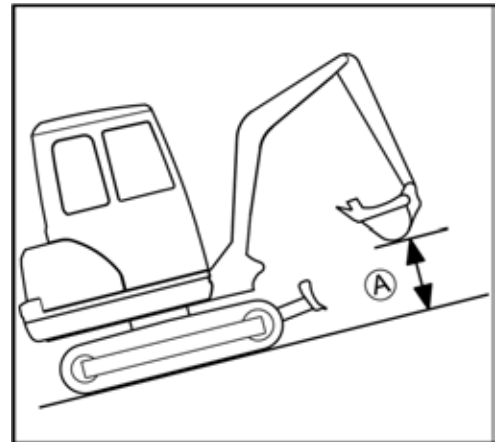

Notes for rubber crawler operation

- Driving or turning on sharp objects or over steps causes excessive wear on the rubber crawlers and will lead to breaking of the rubber crawler or cause the crawler running surface and the steel inserts to be cut.
- Make sure that no foreign objects get stuck in the rubber crawler. Foreign objects lead to excessive crawler wear and can cause it to break.
- Keep oil products away from the rubber crawlers.
- Remove any fuel or hydraulic oil spilled on the rubber crawlers.

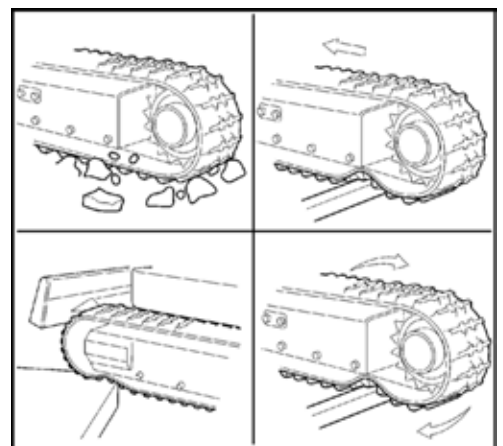

Making sharp turns

- On streets with a high-friction tarmac, e.g. concrete, do not make sharp turns.

Protecting the crawler against salt

- Do not work with the machine on the seashore. (The salt will cause the steel insert to corrode.)

Operating the controls during excavation work



Always observe the following safety instructions when working with the excavator.

- Never crush concrete or boulders using side boom swings with the bucket.
- Do not use the dropping action of the bucket for excavation.
- Never fully extend the cylinders. Always keep a certain safety margin, especially when operating with a breaker (accessory).
- Never use the bucket as a hammer to drive posts into the ground.
- Do not drive or dig with the bucket teeth rammed into the ground.
- When loading soil, do not dig the bucket deeply into the ground. Instead, make relatively shallow slices with the bucket out as far as possible. This technique reduces the stress on the bucket.
- When working in water, the water should only reach up the lower edge of the swivel frame.
- After using the machine in water, always grease the pins at the bucket and arm with grease until the old lubricating grease emerges.
- When digging with the boom above the dozer, make sure that the boom cylinder does not come into contact with the dozer.
- Never use the excavator as a crane, unless it is equipped with craning equipment (accessory).
- Adhering soil can be shaken off when the bucket is being emptied by moving the cylinder to the end of the stroke. Should this not suffice, dump the arm as far as possible and operate the bucket back and forth.
- When excavating, always lower the dozer completely onto the ground.

Operation

Note on using wider and deeper buckets



When using a wider or deeper bucket, take good care when swinging or retracting the front attachments to make sure that the bucket does not hit the cab.

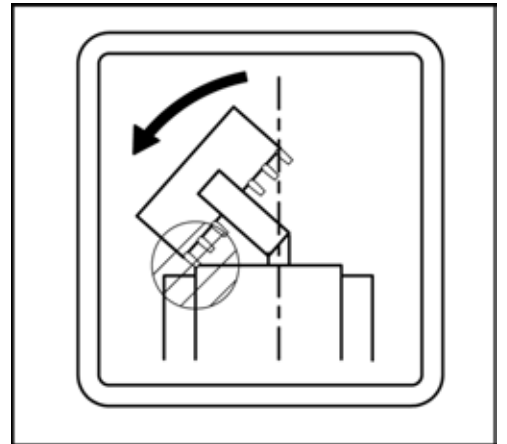

Operating the dozer



When working with the dozer, operate both drive levers with the left hand and the dozer control lever with the right hand.

- To lift the dozer, pull the dozer control lever (1) back.
- To lower the dozer, push the dozer control lever forward.

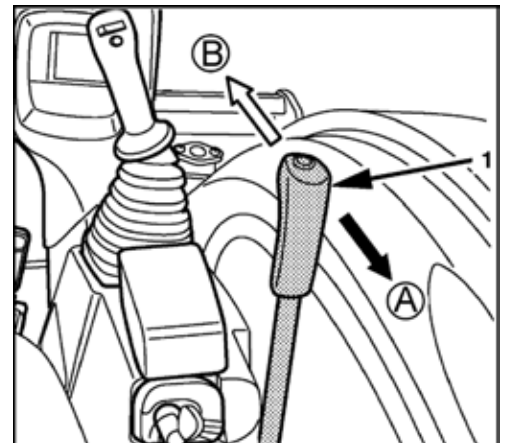

(A) Dozer up.

(B) Dozer down.

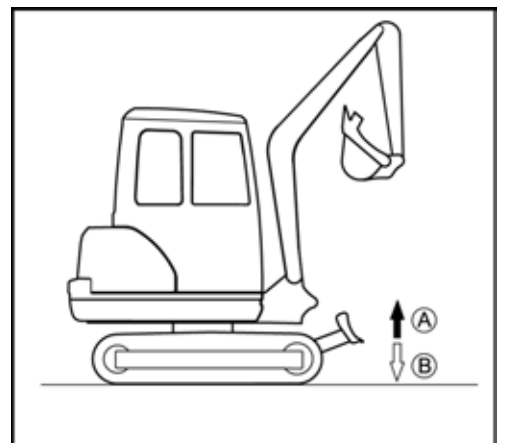

Overview of control lever functions (standard setting)

The figure shows, in connection with the following table, the functions of the left and right control levers.

Control lever		Movement
Right control lever	1	Lower boom
	2	Raise boom
	3	Bucket crowd
	4	Bucket dump
Left control lever	A	Arm crowd
	B	Arm dump
	C	Swivel frame to the left
	D	Swivel frame to the right

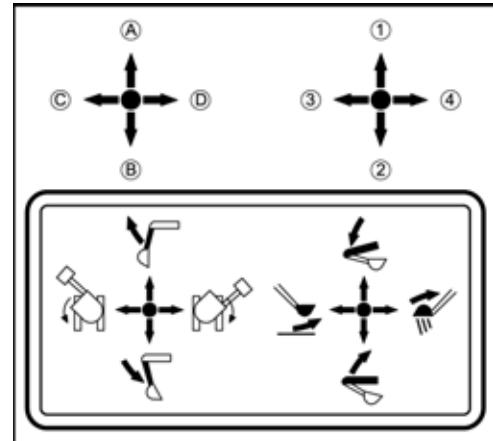

Operating the boom

If the excavator is overloaded, the boom must be lowered until the load rests on the ground. To prevent personal injuries and damage to equipment, do not operate any other functions (e.g. moving the swivel frame).

- To raise the boom, pull the right control lever back (figure/↖).



The hydraulic cylinder of the boom is equipped with a cushioning function, which prevents the excavated material in the bucket from falling out. When the hydraulic system operating temperature is low, the cushioning is delayed for approx. 3 to 5 s. This delay is due to the viscosity of the hydraulic oil and is not a malfunction.

- To lower the boom, push the right control lever forward (figure/↗).

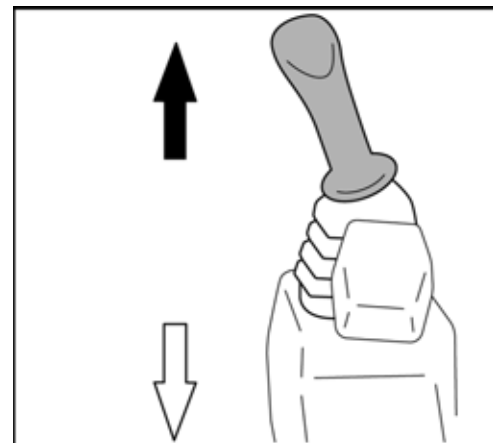

Watch the boom during lowering, so that the boom or the bucket teeth do not hit the dozer.

The boom moves as shown in the figure.

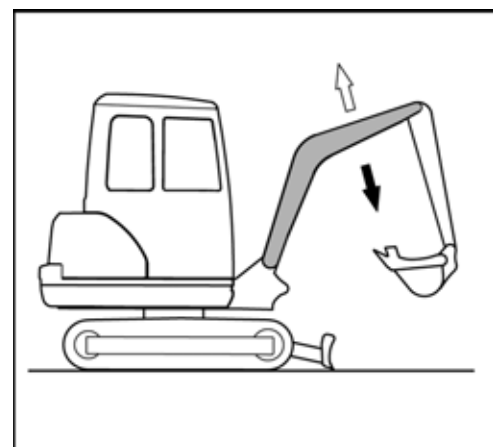

Operation

Operating the arm

- To dump the arm, push the left control lever forward (figure/↑).
- To crowd the arm, pull the left control lever back (figure/↓).

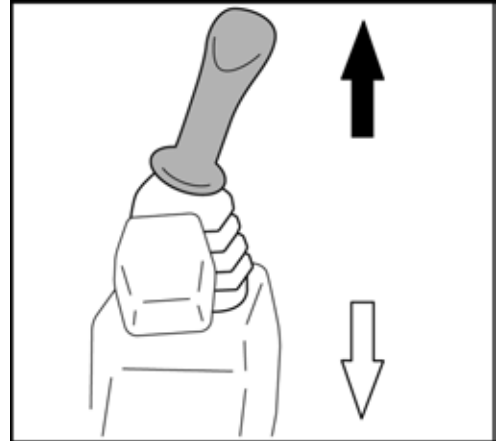

The arm moves as shown in the figure.

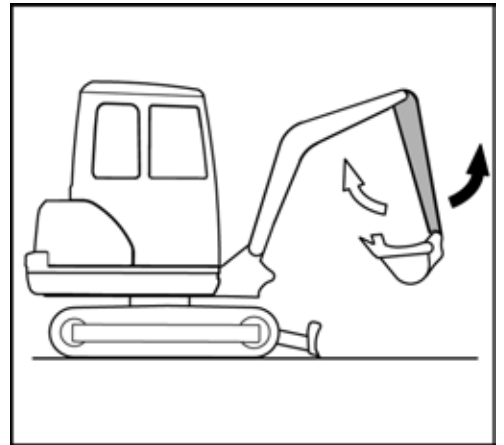

Operating the bucket

- To crowd (digging) the bucket, move the right control lever to the left (figure/←).
- To dump (empty) the bucket, move the right control lever to the right (figure/→).



When crowding the bucket, take care that the teeth do not hit the dozer.

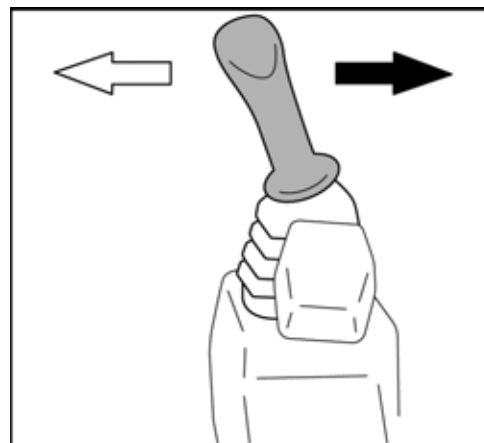

The bucket moves as shown in the figure.

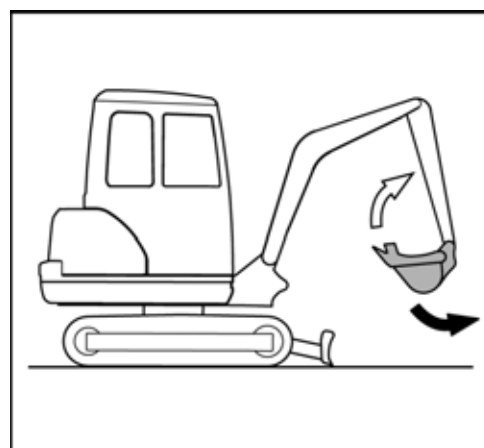

Operation

Swivelling the swivel frame



No person is allowed to stand in the swivel area during the movement.



Swivel carefully to avoid any contact of the front attachments with adjacent objects.

- To turn anticlockwise, move the left control lever to the left (figure/←).
- To turn clockwise, move the left control lever to the right (figure/⇒).

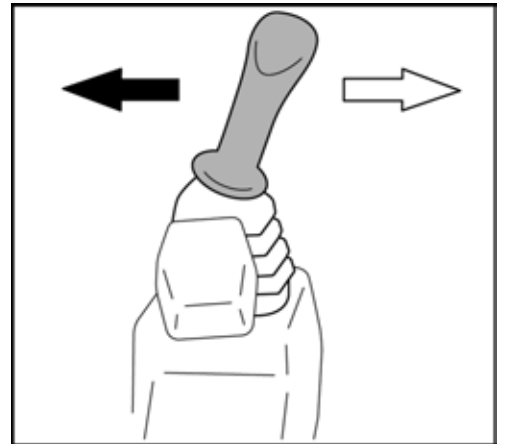

The turning operation takes place as shown in the figure.

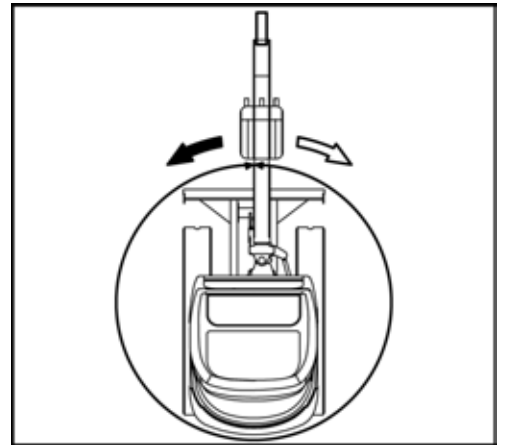

Swinging the boom



No person is allowed to stand in the swing area during the movement.



Swing carefully to avoid any contact of the front attachments with adjacent objects.

- To swing the boom counter-clockwise, press the boom swing pedal on the left-hand side (figure/←).
- To swing the boom clockwise, press the boom swing pedal on the right-hand side (figure/⇒).

The figure details the swing movement.

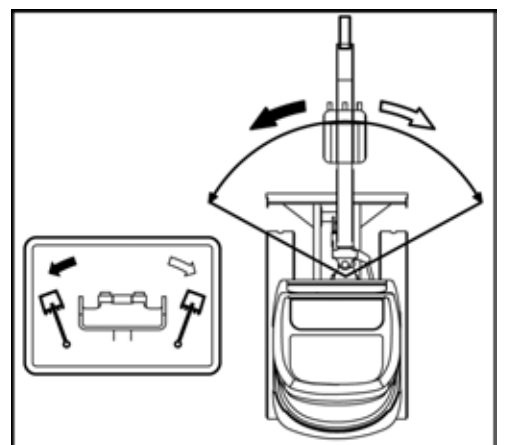

The boom swing control pedal can be secured against inadvertent operation by lowering the locking flap. Fold the locking flap when the boom swing pedal is not in use.

Operating the auxiliary ports

Implements are operated using the auxiliary ports.



Only implements approved by KUBOTA may be used. The implements must be operated in accordance with the operating instructions supplied with them.



For auxiliary port specifications, see the "Specifications" section" (page 39).



Make sure that, before carrying out the activities in the auxiliary port connectors, the pressure relief of the hydraulic equipment (page 93) and the auxiliary port connectors (page 93) has been carried out. Depending on the operation setting, the return change valve has to be set to the appropriate position (page 92).



The auxiliary ports may only be activated when an implement is attached.



If the auxiliary ports have not been in use over a long period of time, dirt may have accumulated on the pipe connections. Before installing the implement, drain approx. 0.1 L of hydraulic oil at each port.



Catch the drained hydraulic oil in a container and discard it in accordance with the valid environmental regulations.

- Start the engine (page 69) and keep it at idle speed until the operating temperature has been reached.

Activating the auxiliary port function

The auxiliary port is used for hydraulic implements, such as a breaker. You can set the flow rate prior to operating auxiliary port. Refer to the section for the flow rate setting (page 88) for details.

Switch on the auxiliary port using the auxiliary port enable switch (1). This switch is active when the left control console is lowered and the starter switch is in the RUN position. When the auxiliary port is switched on, the indicator Auxiliary port (2) comes on or flashes.

Using this switch, you can also set the operation settings.

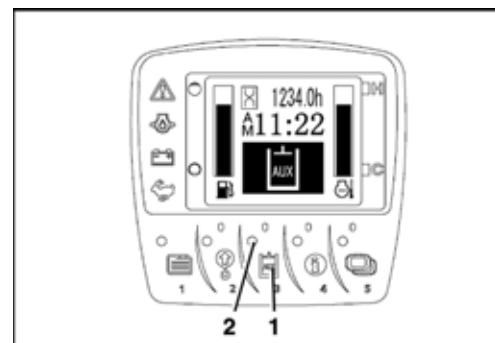

Operation

Auxiliary port 1

The following figure illustrates the auxiliary port 1 and auxiliary port 1 rocker switch (3) connectors.



The proportional control enables you to smoothly control the implement speed. Example: If you move the rocker switch half a turn to the left, the implement moves at half speed.

- Move the auxiliary port 1 rocker switch in direction (→). The oil will flow towards connector (1) on the right side of the arm.
- Move the auxiliary port 1 rocker switch in direction (←). The oil will flow towards connector (2) on the left side of the arm.

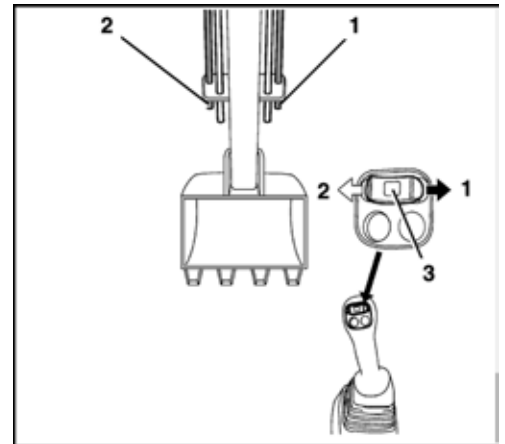

Auxiliary port 2

The following figure illustrates the auxiliary port 2 and auxiliary port 2 rocker switch (5) connectors.



The proportional control enables you to smoothly control the implement speed. Example: If you move the rocker switch half a turn to the left, the implement moves at half speed.

- Move the auxiliary port 2 rocker switch in direction (→). The oil will flow towards connector (3) on the right side of the arm.
- Move the auxiliary port 2 rocker switch in direction (←). The oil will flow towards connector (4) on the left side of the arm.

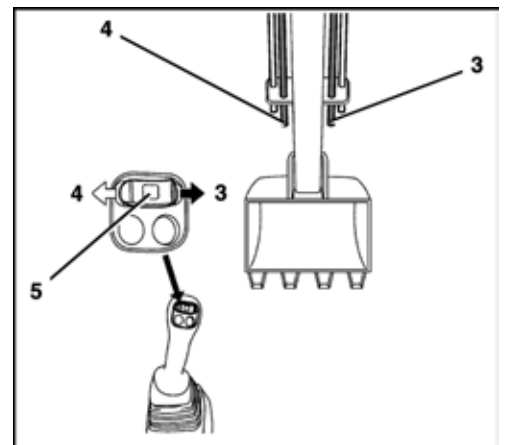

One way hold operation



For one way hold operation, the return change valve has to be set to the direct return flow position (page 92).

- Activate the operation setting for the "one way flow".

Switching on

- Briefly push the one way hold switch (1). The oil flows on one side to auxiliary port 1 (2) on the left side of the arm.

Switching off

- Briefly press the one way hold switch to switch off the oil flow, or
- press the rocker switch for auxiliary port 1 (3) briefly to the right or left to stop the oil flow.

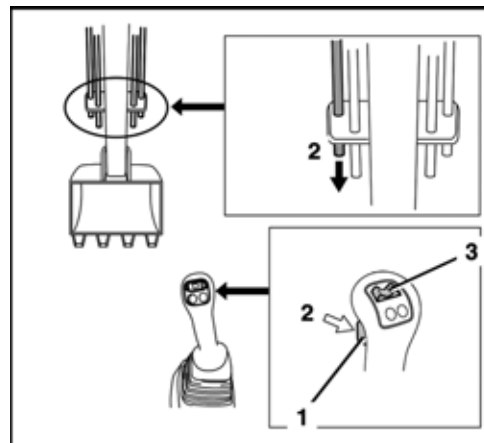

Operating modes

The auxiliary port connector is preset at the factory, enabling four operating modes to be selected. Up to six operating modes can be preset.

Whenever the auxiliary port enable switch (following figure/button 3) is pressed the service mode changes by one level. The symbol and flow rate index in the display change accordingly.

Whenever the auxiliary port button is pressed the service mode changes by one level.



When the starter switch is turned to the RUN position the most-recently used setting is activated.

Operation

Select the mode of operation

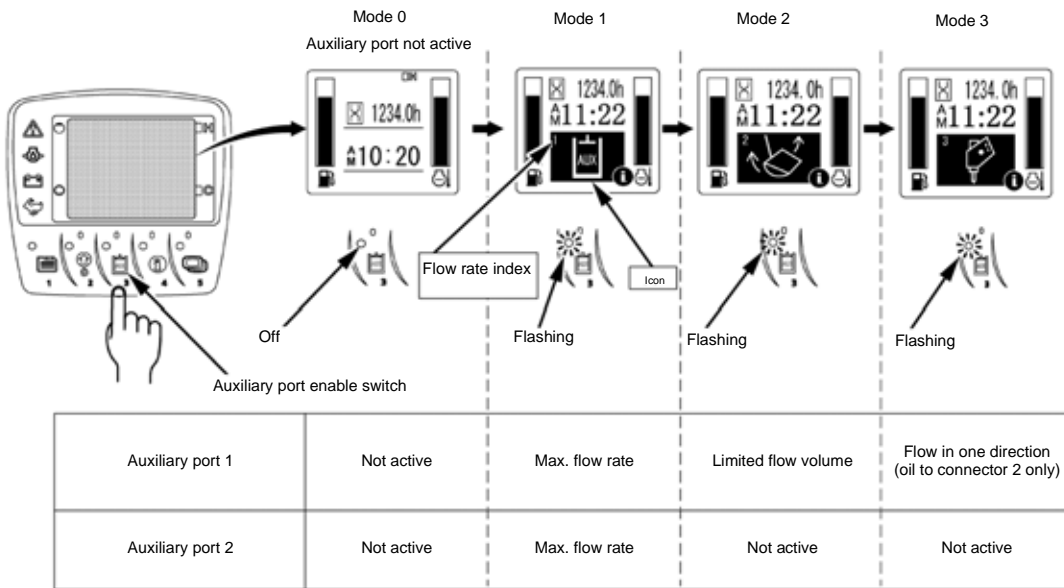

When an operating mode has been selected and there is an "i" (2) at the bottom right of the symbol (1), you can view the flow rate that has been set by pressing the information button (button 4). During this, the indicator (3) flashes.

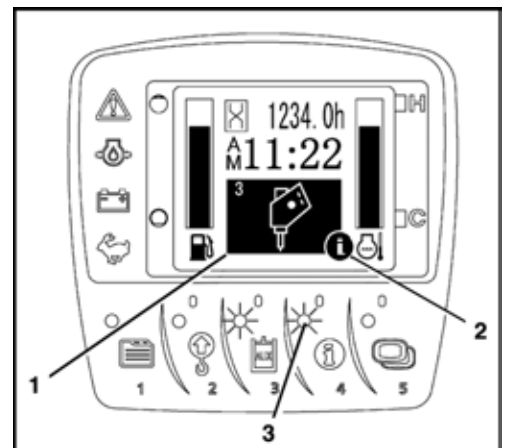

The flow rate set for auxiliary port 1 is shown on the right of the display, that of auxiliary port 2 on the left. The height of bar "A" shows the flow rate of the respective connectors (1, 2, 3, and 4).

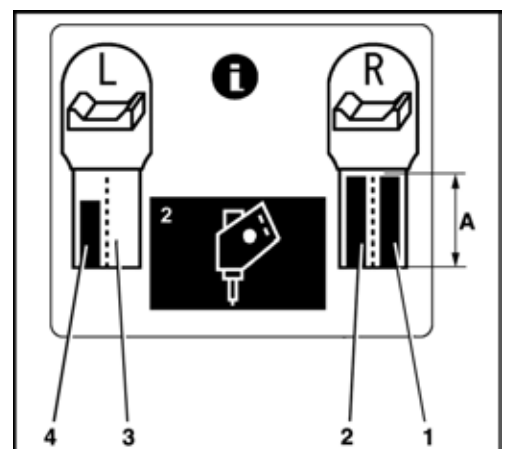

Flow rate setting

Suppose the same implement has to be attached to a different excavator. Even when using identical flow rate settings for the other excavator, the working speed may differ. For each excavator, you need to individually adjust the flow rate settings. Upon changing the implement, you need to determine and adjust the optimum flow rates for the new implement.



The flow at auxiliary port 1 is not constant when using a different function or if a relief valve is responding.



It is recommended to adjust this setting during the operation of the implement.

- Turn the starter switch to the RUN position.
- Press button 1.
- The display message as in the figure on the right appears.

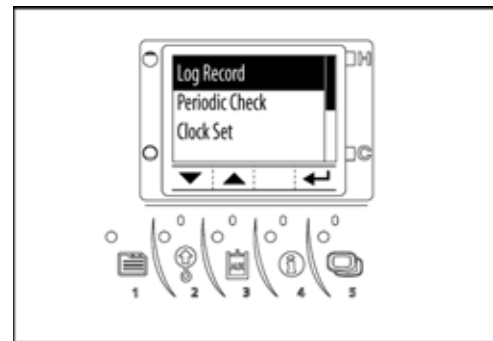

- Press button 2 or 3 until "Sp Flow Ctr Set" is selected in the display.
- Press button 5 to select.

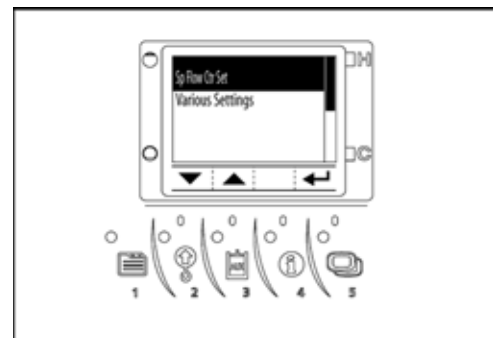

Setting with flow rate index:

- Press button 5 until the desired flow rate index (1) appears.

Settings with symbol:

- Press button 4 until the arrow marking (2) on the symbol (3) appears.
- Press button 2 or 3 until the desired symbol appears.

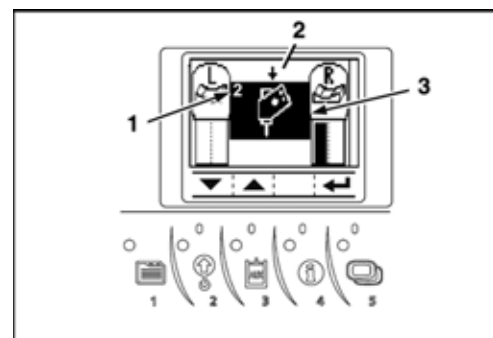

Operation

You can select the following symbols:

1. Auxiliary port (default)
2. Brush cutter
3. Rotary grapple
4. Grapple
5. Auger
6. Dipper bucket
7. Breaker
8. Tilt bucket
9. Deactivated



There is no relationship between the icons and the flow control settings. Select icons to suit the images of attachments to be connected.

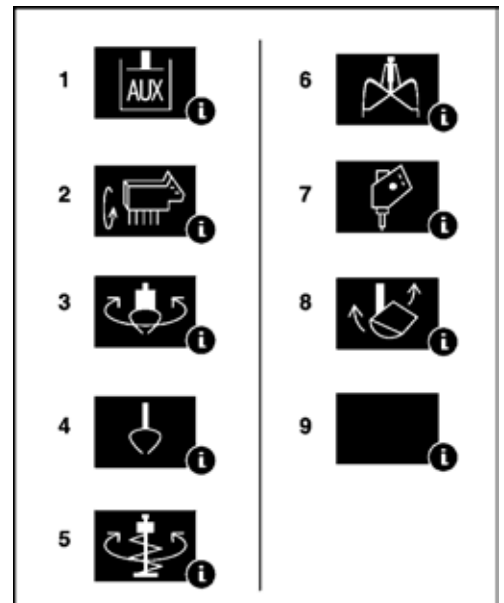

If the "Deactivated" symbol is preset for an operating mode it is skipped during selection.

Setting example:

- Operating mode 1 → "Auxiliary port" (default)
- Operating mode 2 → "Breaker"
- Operating mode 3, 4, 5 → "Deactivated"

Press button 3 to change to operating mode 1, operating mode 2 and normal display in that order.

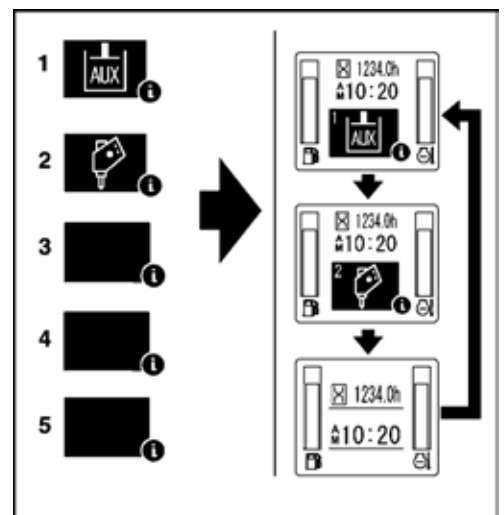

The maximum flow rate can be set for each auxiliary port connector.

- Press button 4 until the arrow marking (1) on the bar graph (2) for connector 2 of auxiliary port 1 appears.
- Press button 2 or 3 to set the height of the bar graph.
- Press button 4 to change to the next connector and carry out the setting there.

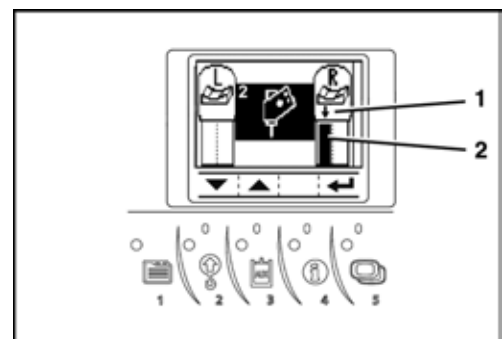

When the bar graph has been set to the highest level, the flow rate is at its maximum.

When the bar graph has been set to its lowest level (no bar is visible), the flow is blocked and no oil will flow.

- Press button 1 to complete the settings and return to the normal display.



It is possible that some implements will not be activated even when the bar graph is not at its lowest level.

Even when the bar graphs are at the same height, it is possible that the implements will not operate identically.

This does not constitute a defect. In this case, the flow rates must be optimised correspondingly for the implements.

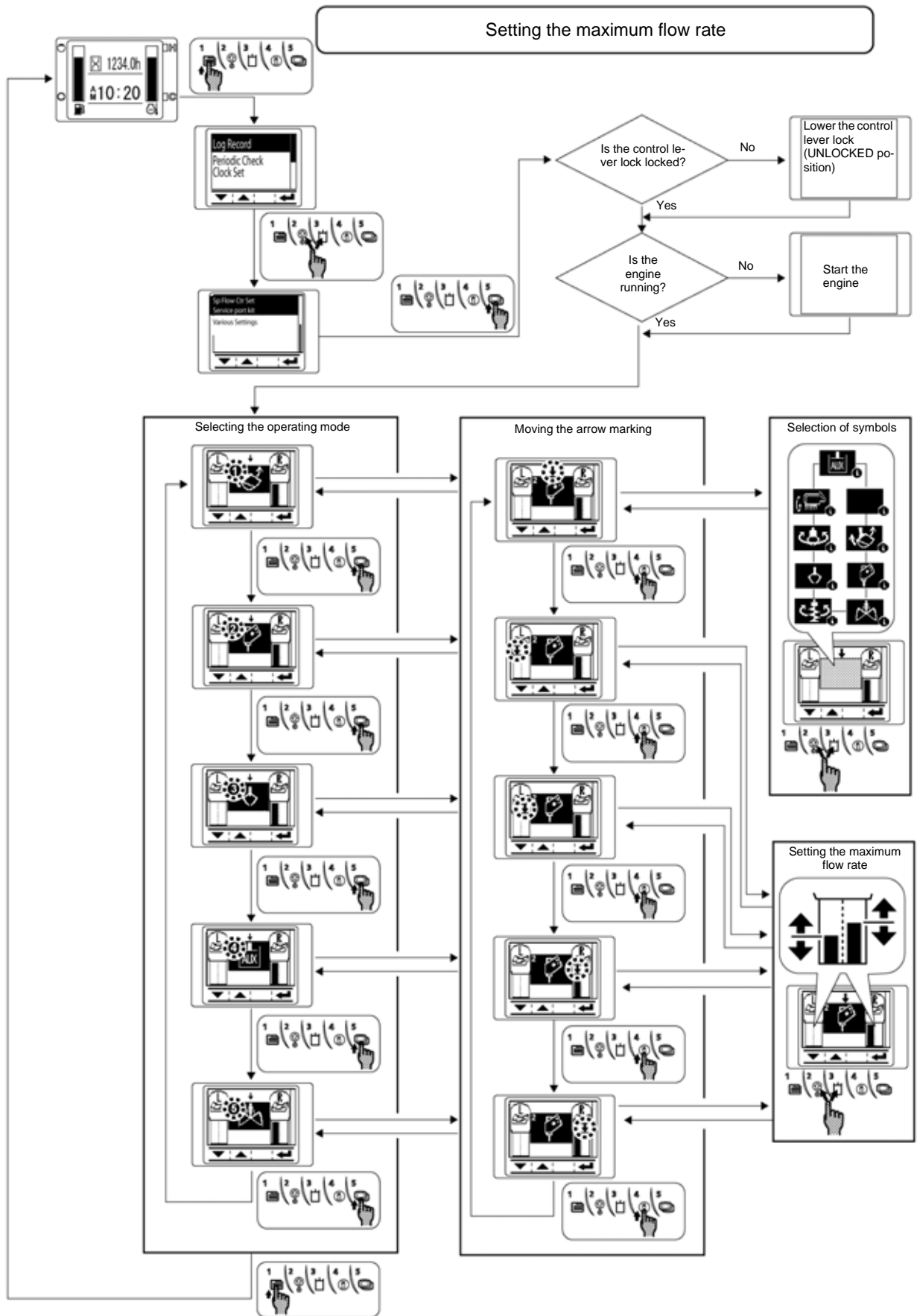

Return change valve for direct return flow

The change valve has two settings.

When "direct return flow" is enabled, the return flow is directed from the implement to the hydraulic oil tank via the return filter. The return flow is directed via the right auxiliary port 1 connector at the arm only.

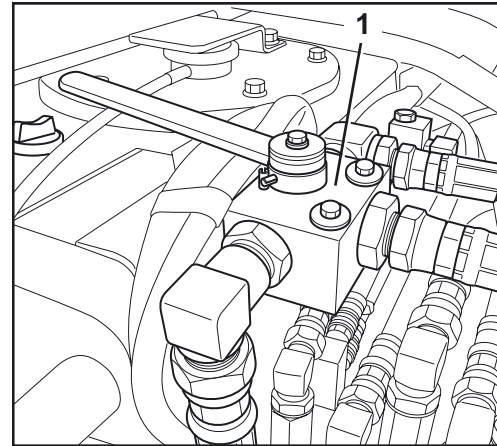

When "indirect return flow" is enabled, the return flow is directed from the implement to the return filter via the control valve and then to the hydraulic oil tank. In that case, the return flow may use the left or right auxiliary port 1 connector of the arm (depending on the position of the rocker switch for auxiliary port 1).

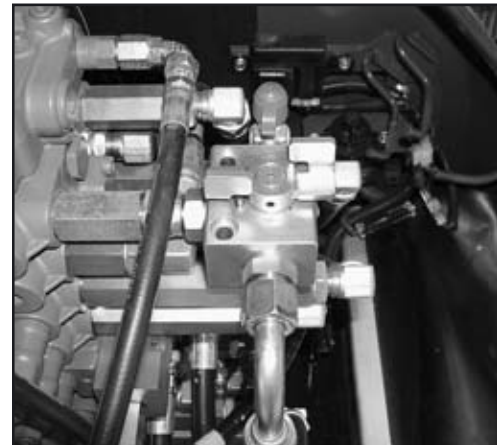

Move the return change valve to the required position as shown in the figure, depending on the action of the implement being used (rotary or breaking).

Operation

Pressure relief of the hydraulic system

- Lower front attachments and dozer completely.
- Turn the starter switch to the STOP position.
- Wait until the engine has come to a standstill.
- Turn the starter switch to the RUN position.



Do not start the engine!

- Lower the left control console (1) and make sure that the control lever lock (2) engages.
- Move control levers (3 and 4) several times to limit stop in all directions.

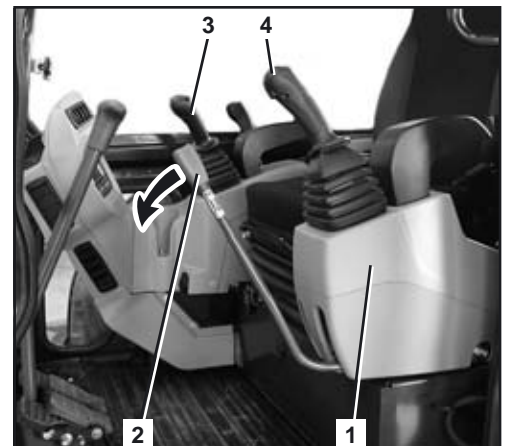

The hydraulic system is pressure relieved.

Pressure relief of the auxiliary ports



The excavator comes with auxiliary port 1 only or with auxiliary port 2 additionally. The following description illustrates the pressure relief process for both auxiliary ports. According to excavator equipment, the corresponding description is to be applied.

- Lower front attachments and dozer completely.
- Turn the starter switch to the STOP position.
- Wait until the engine has come to a standstill.
- Turn the starter switch to the RUN position.



Do not start the engine!

- Lower the left control console (1) and make sure that the control lever lock (2) engages.
- Press the auxiliary port enable switch (1) and turn on the auxiliary port function.

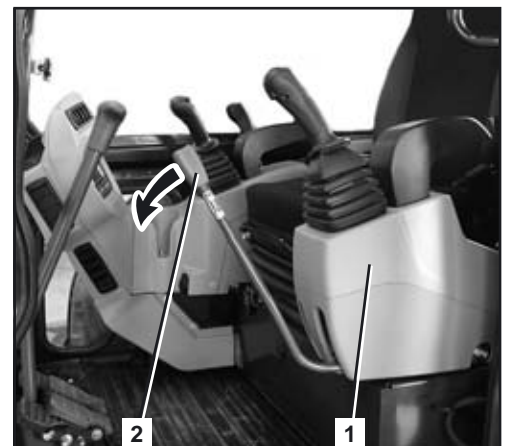

When the auxiliary port is switched on, the indicator Auxiliary port (2) comes on or flashes.

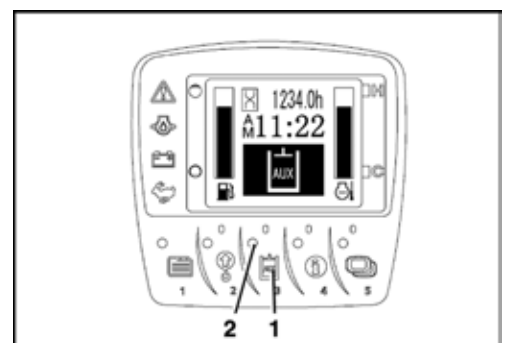

You will see the setting of the flow rates in the display. The bar height "A" shows the flow rate at the respective auxiliary port connectors (1, 2, 3 and 4).

If the bar graph is set to the lowest level (as shown in connector 3, no bar obvious), flow is blocked and there is no oil flow.



If the flow is blocked, the pressure cannot be relieved completely. The hydraulic couplings at the auxiliary port connectors can jam as a result. Then connection or separation of the hydraulic cables of attachments is not possible. Switch to a different mode, if available (page 86), or increase the flow rate (page 88).

- Make sure that the flow rates are not set to the lowest level.
- Rocker switch auxiliary port 1 (3) on the right control lever must be pushed over completely to the right and left.

The auxiliary port connectors (1 and 2) are pressure relieved.

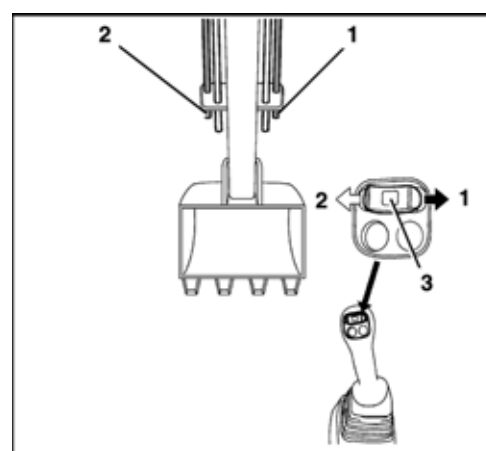
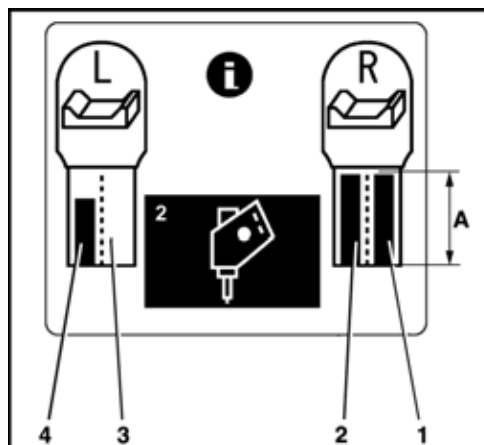

- Rocker switch auxiliary port 2 (5) on the left control lever must be pushed over completely to the right and left.

The auxiliary port connectors (3 and 4) are pressure relieved.

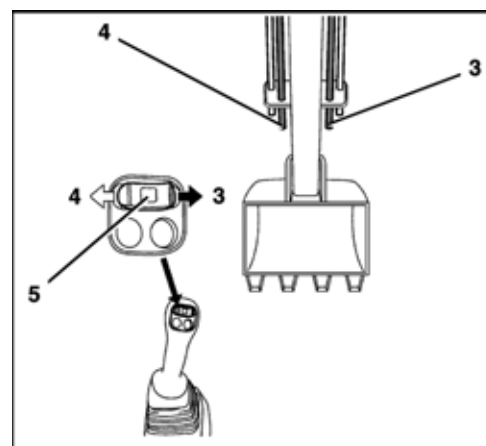

Placing out of operation



Park the excavator in such a way that it can not move and is secured against unauthorised use.

- Drive the excavator onto level ground.
- Extend the hydraulic cylinders as follows:

Boom:	Half-extended
Arm:	Half-extended
Bucket:	Half-extended
Dozer:	Lowered to the ground
Swing mechanism:	Front attachments lowered centrally to the ground
- Stop the engine (page 70).
- Remove the key.
- Unbuckle the seat belt and lift the left control console.
- Refuel the excavator, if necessary (page 105).
- Close and lock the cab door. The key must remain with the operator.
- Check the excavator for external damage and for leaks. Any defects must be repaired before the next start.
- In case of a heavy accumulation of dirt in the area of the tracks and the hinges at the front attachments, clean the excavator (page 129).

Operating the heating and air-conditioner system (optional)



All the heating and air-conditioner system operations described below must be carried out while the engine is running.

Heating the cab

- Set the temperature control (1) to the desired position.
Blue → Cold
Red → Warm
- Set the blower switch (2) to position 1, 2 or 3.
- Set the air nozzles to the desired position.

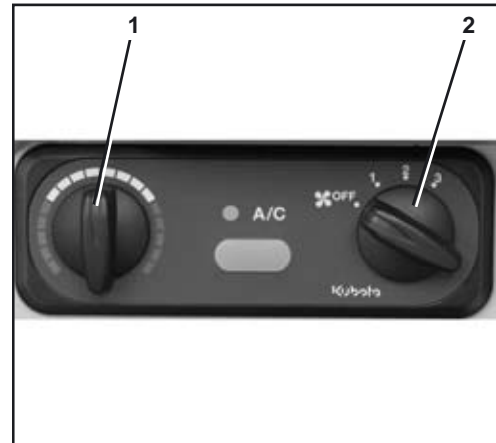

In order to avoid a heat backup and therefore damage to the ventilation system, do not cover the air nozzles and interior air filter with objects (e.g. bags or clothing) when the heater is in operation.

Cooling the cab

- Set the temperature control (1) to the "Cold" position.
Blue → Cold
Red → Warm
- Set the blower switch (2) to position 1, 2 or 3.
- Use the air-conditioner switch (3, optional) to switch the system on. The indicator (4) lights up.
- Set the air nozzles to the desired position.

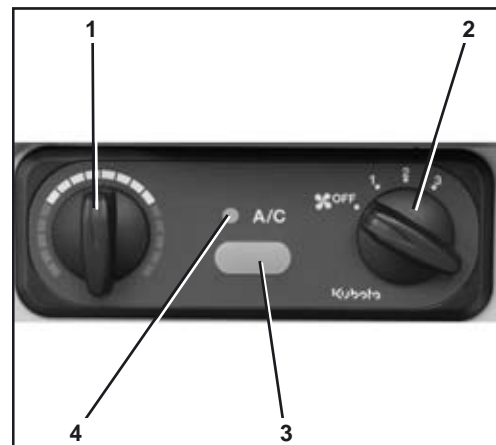

Make sure that the cab door is closed while the heating or air-conditioner system is running.

- Set the air nozzles to the desired position.

Operation

De-icing or demisting the windows

Proceed as follows to de-ice the windows or clean them of condensation:

- Set the temperature control (1) to the "Warm" position.
Blue → Cold
Red → Warm
- Set the blower switch (2) to the 3 position.
- Use the air-conditioner switch (3, optional) to switch the system on. The indicator (4) lights up.

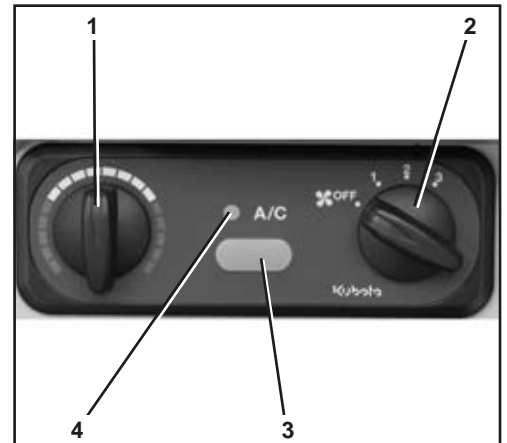

The air-conditioner will dehumidify the cab air.



Make sure that the cab door is closed while the heating or air-conditioner system is running.

- Direct the air nozzles towards the front window.

Operating the wiper/washer system

All cab models are equipped with a wiper/washer system.



Risk of damage to components!

When you turn on the wiper while the windscreen is opened, the wiper can hit the adjacent cab components causing damage to the wiper.

- *Do not turn on the wiper switch while the windscreen is open.*

Switching on the windscreen wiper

- The starter switch is in the RUN position.
- Press the switch (1) to the WIPER/WASHER position.

The wiper operates as long as the switch remains in this position.

- To switch off, press the switch (1) to the OFF position.

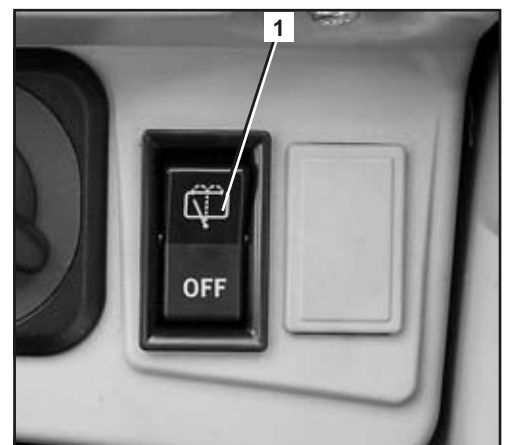

In extremely cold weather conditions, make sure the wiper rubber does not stick to the window. This can damage the wiper rubber or the wiper motor.



Only switch on the wiper when the window glass is wet. If necessary, switch on the washer system first.

To turn on the washer system

The washer system can be operated irrespective of whether the wiper is on or off.

If the wiper is on:

- Press the switch (1) to the WIPER/WASHER position again and hold it down.

If the wiper is off:

- Press the switch (1) to the OFF position and hold it down.

The washer system runs for as long as the switch is held down.



Do not operate the washer system if its reservoir is empty as running dry could damage the pump.

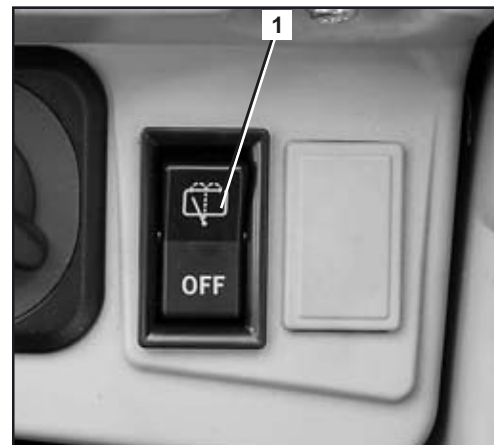

Operating the room light

- The starter switch is in the RUN position.
- Press the switch (2) to the ON position.

The interior light (1) is illuminated as long as the switch remains in this position.

- To switch off, press the switch (2) to the OFF position.

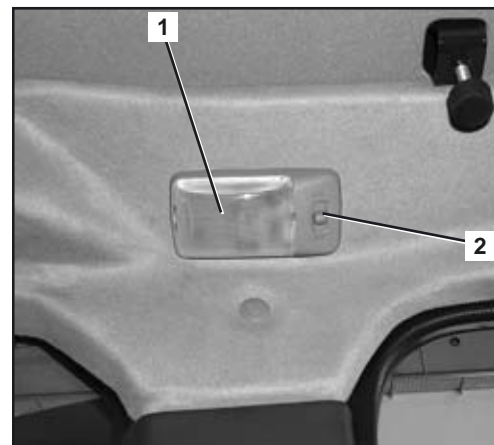

Operating the rotary beacon

- The starter switch is in the RUN position.
- Press the rotary beacon switch (1) to the ON position.

The rotary beacon operates as long as the switch remains in this position.

- To switch off the rotary beacon, press the switch to the OFF position.

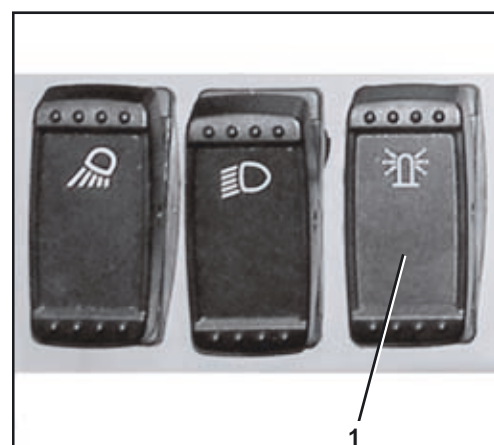

Operation

Operating the 12 V plug

- Open the cover cap (1) and put the load into the 12 V plug.



The rated current of the connected load must not exceed 10 A.

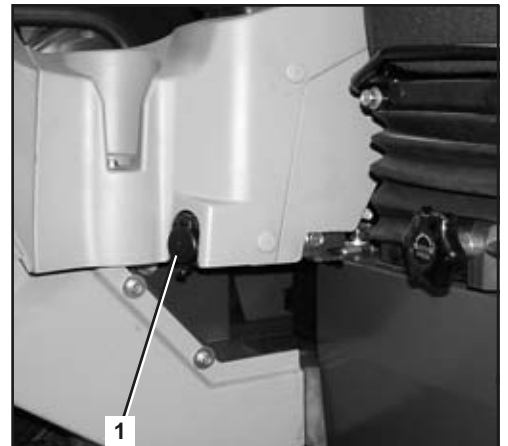

Opening and closing the cab door

Opening the cab door from outside

- Unlock the cab door at the door lock (3).
- Open the cab door by pulling at the door handle (1) and lock the door by attaching the hook (2) at the cab wall.

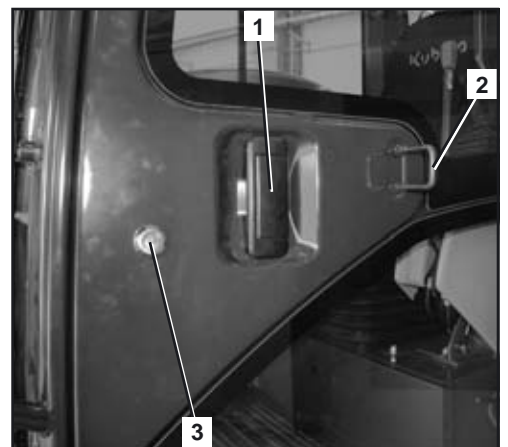

Closing the cab door

- Press down the release lever (1) and pull the cab door into the lock.

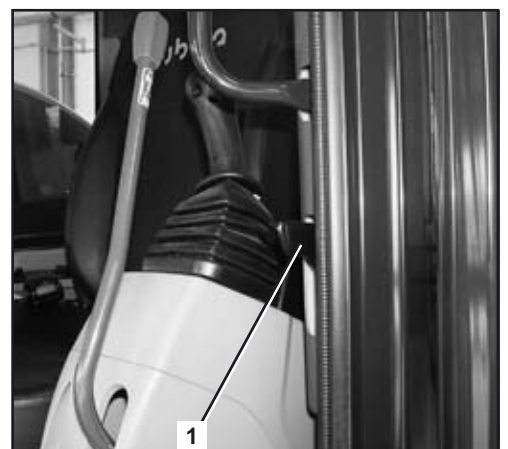

Opening the cab door from the inside

- Pull the release lever (1) and open the door. If the cab door is not closed again right away, lock the door at the cab wall.

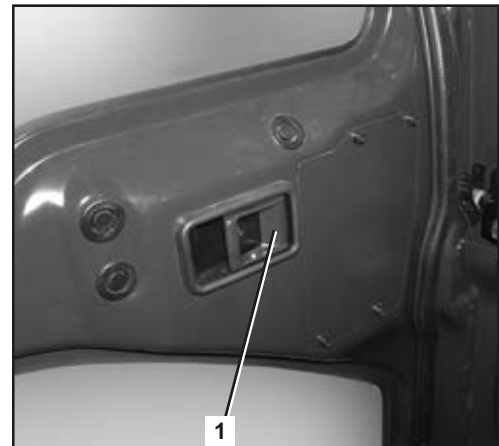

Opening and closing the windows

Front window



Always lock the front window. Do not stay in the cab and operate the excavator with the front window unlocked. When opening the window, always keep both hands on the grips (2) to prevent injury by pinching or crushing.



The front window is opened and closed from the operator's seat.

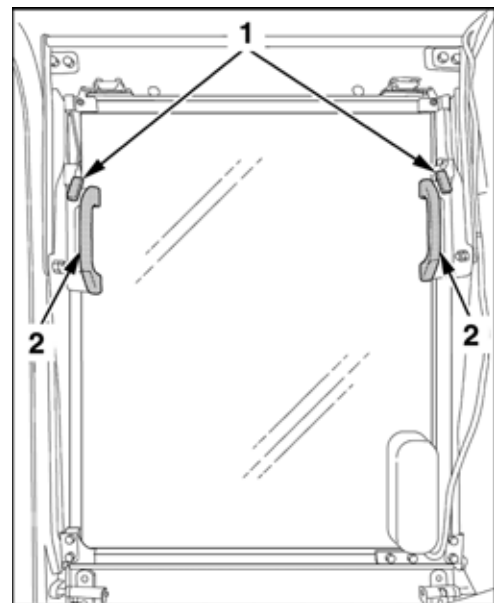

Opening

- Press the right and left lock bars (figure above/1) inwards simultaneously and push the front window upward at both grips (figure above/2) in the guide rails as far as the stopper. Lock the front window at the endpoint. Check that the front window is locked.



Do not release the handles when raising the window as the front window could suddenly rise in an uncontrolled way and strike the operator's head. Please follow the safety instructions on the side window.

Closing

- Press the right and left lock bars (figure above/1) simultaneously and, using both grips (figure above/2), push the front window forward within the guide rails up to the stopper. Lock the front window at the stopper by releasing the lock bars. Check that the front window is locked.

Operation

Side window

- Pull the grip (1) to release the lock and pull side window open to the rear or to the front.
- To close the side window, slide it forward or backward until the lock snaps in at the window frame.

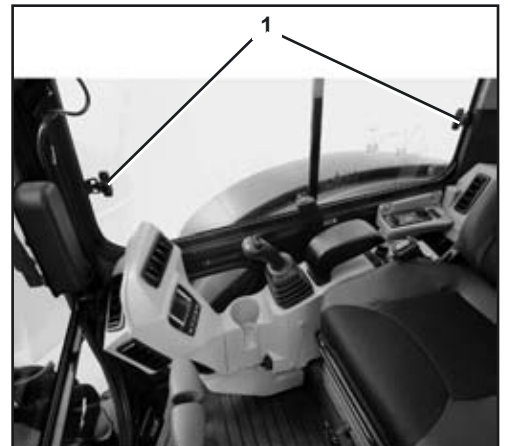

Operating the working light (boom)

- The starter switch is in the RUN position.
- Press the working light button (1) to the ON position. Both the working light on the boom and the instrument lighting are turned on.
- To switch off the working lights on the cab, press the button to the OFF position.



During work on public roads other road users must not be blinded.

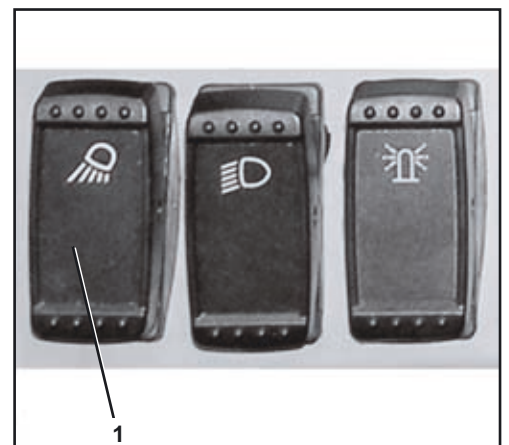

Operating the working lights (cab)

- The starter switch is in the RUN position.
- Press the working light button (1) to the ON position. The working lights on the cab are turned on.
- To switch off the working lights on the cab, press the button to the OFF position.



During work on public roads other road users must not be blinded.

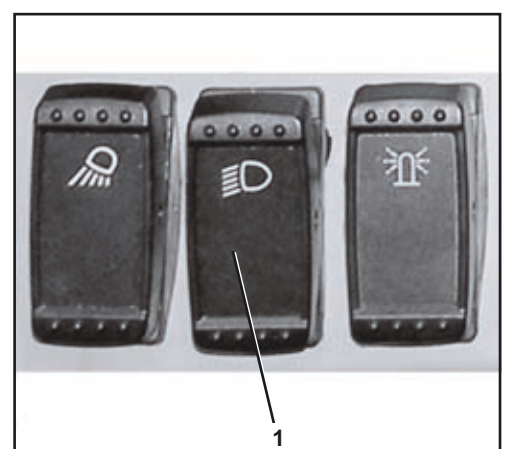

Cold weather operation

Operating the excavator at an ambient temperature below 5 °C is regarded as cold weather operation.

Necessary preparations prior to the winter season

- If necessary, replace the engine oil and hydraulic oil with those of the viscosities specified for winter.
- Only use regular diesel fuel with winter additives. Do not mix petrol and diesel fuel.
- Check the battery's state of charge. In case of extremely low temperatures, it may be necessary to remove the battery after work and store it in a heated room.
- Check the antifreeze strength in the cooling system (page 129). If necessary, add antifreeze until the protection ranges from -25 °C to -40 °C.
- Apply talcum powder or silicone oil to all rubber seals at the windows, the cab door and the side window guide rails.
- Lubricate all locks, except the starter switch, with graphite lubricant.
- Grease the cab door hinges.
- Fill the washer system with a antifreeze window cleaner (page 105).

Operation during the winter season

- The excavator must be cleaned after work is finished (page 129); Special attention must be paid to the crawlers, the front attachments and the piston rods of the hydraulic cylinders. If the excavator is cleaned with a water jet, it must then be parked in a dry, frost-free and well-ventilated enclosed space.
- If necessary, park the excavator on boards or mats in order to prevent freezing to the ground.
- Before starting, check if the piston rods of the hydraulic cylinders are free of ice to avoid damage. Also check if the crawlers are frozen to the ground. If so, do not take the excavator into operation.



Be careful when getting on and off, the crawler could be slippery.

- Start the engine (page 69) and let it run at idle speed until the engine has accommodated to the outside temperature. Before you start working with the front attachments, warm up the excavator until the operating temperature is reached.

Jump-starting the excavator



Only a vehicle or starting device with a 12 V power supply may be used.



The operator must remain seated on the operator's place, the battery jumper cables must be connected by a second person.

- Make the battery accessible, and remove the positive terminal cover.
- Position the other vehicle or starting machine beside the excavator.



Only use cables with an appropriate cross section as jumper cables.

- Connect the positive terminal of the excavator battery with the positive terminal of the helping vehicle (see figure).
- Connect the negative terminal of the helping vehicle to the frame of the excavator. Do not use the negative terminal of the excavator battery. The connecting point on the frame must be blank and clean.

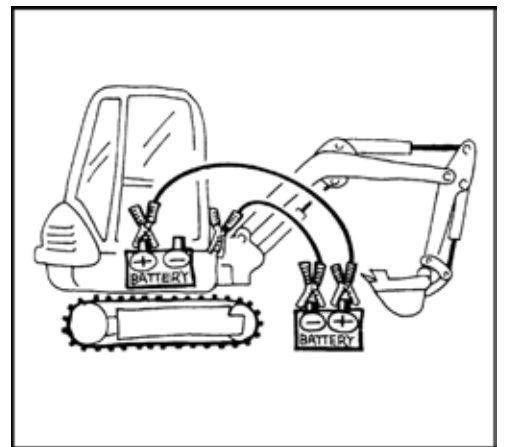

- Start the helping vehicle and let it run at a higher idle speed.
- Start the engine (page 69) and let it run at idle speed. Check if the charge lamp turns off after starting.
- Disconnect the jumper cable at the frame of the excavator first, and then at the negative terminal of the helping vehicle.
- Disconnect the second jumper cable from the positive terminal of the excavator battery first, and then from the positive terminal of the helping vehicle.
- Place the positive terminal cover onto the excavator battery.
- If the jumper cables will be required for the next start of the excavator, check the battery and the alternator's charging circuit, contact skilled personnel, if necessary.

Emergency stop functions

In case of emergency, you can switch off the engine and lower the boom manually.

Engine stop knob

If the engine cannot be stopped with the key, it can be stopped manually.

- To stop the engine, pull the knob (1) until the engine stops.
- After the engine has stopped, push in the knob.

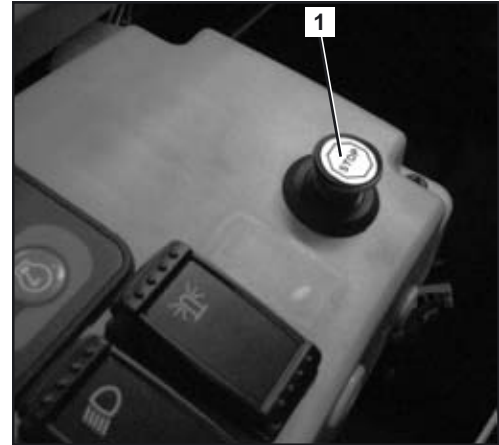

The excavator may only be taken back into operation after the malfunction has been eliminated.

Manual lowering of the front attachments

The boom and arm can be lowered in case of an engine failure or if malfunctions occur in the hydraulic system.

- The starter switch is in the RUN position.
- If necessary, lower the boom and the arm with the control levers as described in the "Operating the controls during excavation work" section (page 78).



Make sure nobody is standing in the lowering area before starting the emergency lowering procedure.



The lowering function is available only for a short time, as it is controlled by the accumulator in the hydraulic system. The cylinders extend or retract by force of gravity.

Filling up the washer system

- Open the cap (1) of the washer system reservoir (2) and add water or a cleaning agent.



In winter, use a cleaning agent with antifreeze.

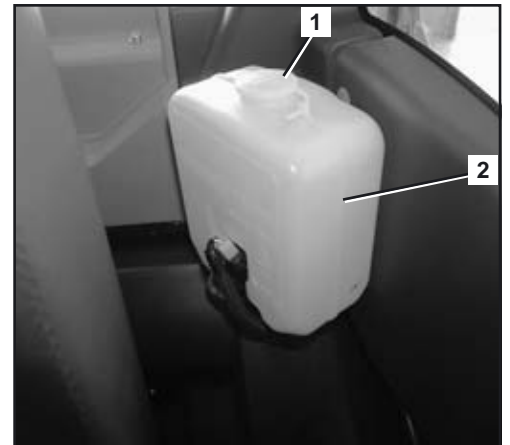

Refuelling the excavator



When refuelling the excavator, smoking, an open flame, or other sources of ignition are not allowed. The danger zone has to be clearly marked with signs. A fire extinguisher must be kept at hand in the danger zone.



Spilled fuel must be bound immediately with an oil binding agent. The contaminated oil binding agent must be disposed of in accordance with the applicable environmental regulations.



If no pumping station is available, the diesel fuel may only be stored in approved canisters.



Refuel the excavator in time so that the fuel tank is not running empty. Air in the fuel system can damage the fuel injection pump.

- Stop the engine.
- Insert the ignition key in the lock (1) of the filler cap (2) and turn it anti-clockwise.
- Open the filler cap by turning it anticlockwise.
- Fill diesel fuel up to the base of the filler neck.
- Screw on the fuel cap and turn the ignition key clockwise to lock the fuel cap.

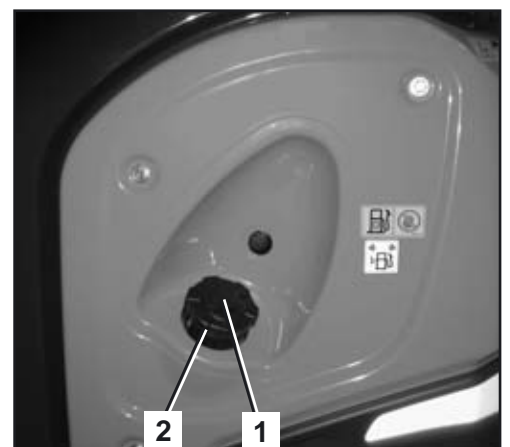

Refuelling the excavator equipped with optional suction pump (only KX057-4)

- Stop the engine.
- Open the left service cover (page 112).
- Remove the filler cap (1) by turning it anticlockwise.
- Fill diesel fuel up to the base of the filler neck.
- Screw on the filler cap and close the service cover.

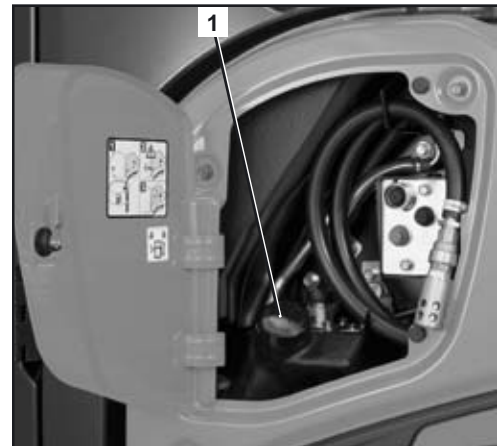

Refuelling the excavator using the optional suction pump (optional only KX057-4)

If the excavator is equipped with a suction pump, you can refuel it directly from a barrel or a jerrycan.



The same safety rules apply as for refuelling the excavator.



Use the suction pump only for pumping diesel fuel. Do not use for any other liquids!

- Stop the engine.
- Open the left service cover (page 112).
- Remove the filler cap (1) by turning it anticlockwise.
- Remove the suction hose (2) from the mounting and put it into the jerrycan.

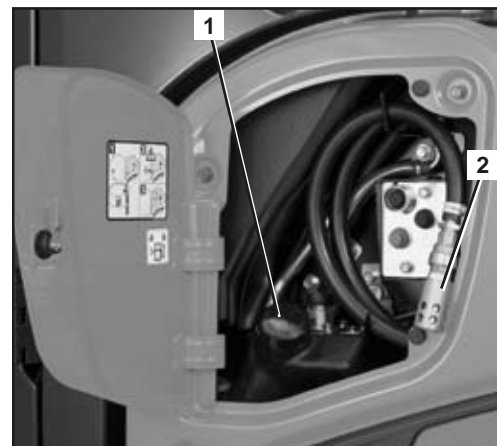

Operation

- Switch on the suction pump. To do this, press the black button (1).



Upon reaching the maximum fill level, the suction pump will automatically switch off.

- To switch it off manually, press the red button (2).
- Screw on the filler cap and close the service cover.

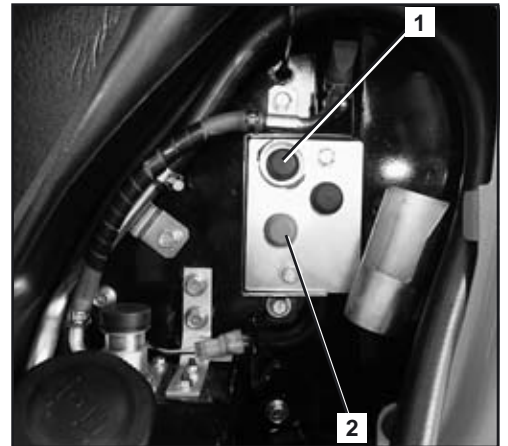

Fill level monitor when refuelling

The momentary fill level during refuelling can be determined by means of an acoustic signal.

Depending on the equipment, the fuel level switch (1) is located above the tank filler neck (2) or on the control unit (3) of the suction pump (optional only KX057-4).

- Press switch (1) to activate fill level monitoring.

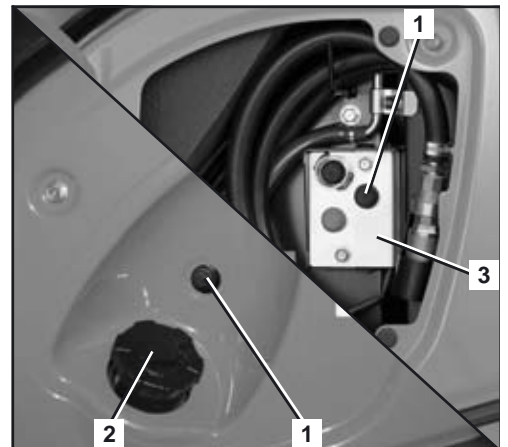

The following signals are output:

Interrupted signal	→ Tank is empty
Periodic signal	→ Tank is being filled
Continuous signal	→ Tank is full



The signal breaks off completely if the flow rate is too low. As soon as there is enough fuel in the tank, the signal restarts.

Press switch (1) after refuelling to deactivate fill level monitoring.

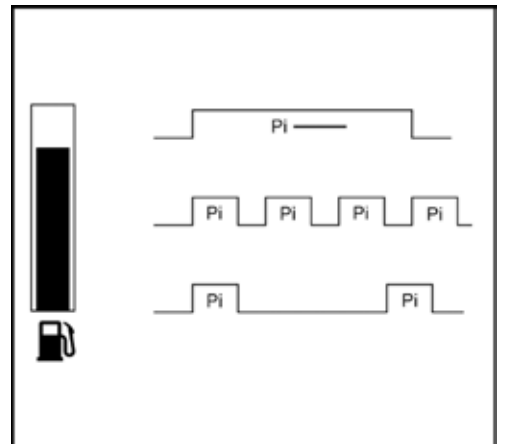

Bleeding the fuel system



If the excavator fuel tank was run empty or the water separator was cleaned, the fuel system must be bled.

- To bleed the fuel system, move the starter switch to the RUN position. The electrical fuel pump will bleed the fuel system automatically within approx. 60 s.
- If the bleeding was insufficient, the engine will stop again. In this case repeat the procedure.

Replacing the fuses



Defective fuses may only be replaced with fuses of the same type and same rating.



The bypassing of fuses, for example by a wire, is not allowed.



If the malfunction can not be remedied by replacing the fuse, or if the fuse blows again when starting, contact skilled personnel.



The main fuses (page 110) of the excavator are situated above the battery.

- Open the cover (1) by unlocking (2) and lowering it.

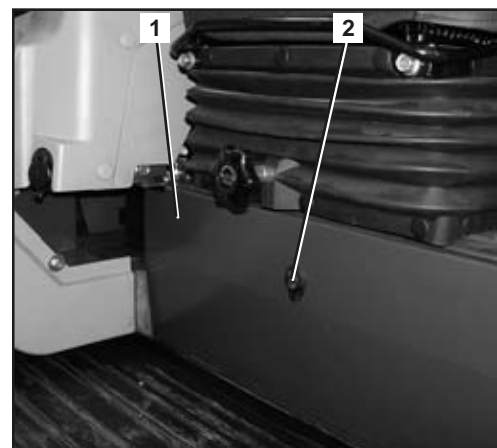

Operation

- Remove the defective fuse from the fuse box (1) and replace it.
- The fuse layout is shown in the figure below.



Fuse layout of the fuse box

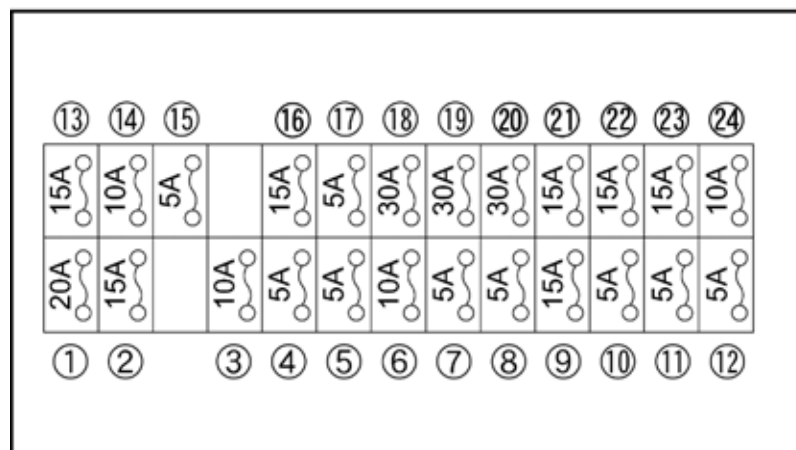

1	Cab working lights	13	AUTO IDLE engine
2	Boom working light	14	Horn switch
3	Horn	15	Control unit
4	Interior lighting	16	Rotary beacon
5	Fuel tank fill level monitoring	17	Heating/air-conditioner controls
6	Alternator	18	Engine cut-off switch
7	Relay, cab	19	Fan motor
8	Display and control unit (AC)	20	Fuel tank suction pump
9	Control unit (AC)	21	12-V socket
10	Fuel pump	22	Radio (AC)
11	Control lever lock	23	Wiper/washer system
12	Starter	24	Heating controls (AC)/air-conditioner controls/dryer (AC)

Main fuses

- Remove the defective main fuse from the main fuse box (1) and replace it.

Fuse layout:

- A → Not assigned
- B → Alternator (80 A)
- C → Main fuse (50 A)
- D → Engine cut-off switch/cab relay (fan motor) (50 A)

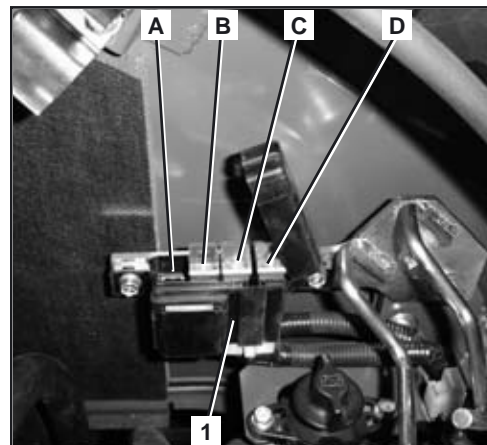

Operating the battery cut-off switch

In order for the excavator to be operated, the battery cut-off switch (1) must be in the ON position.

- A → OFF
- B → ON



If the battery cut-off switch is in the OFF position, most of the electrically powered functions will also be switched off (e.g. horn, fuel fill level monitor, etc.).



The user settings for the display and control unit are saved, and the battery discharges itself only minimally.

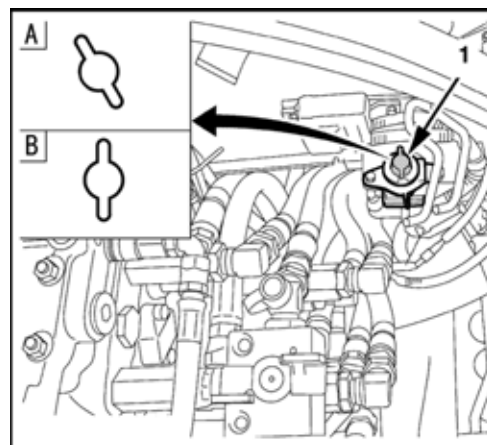

Opening and closing the engine compartment cover

- Insert the key in the lock (1) of the engine compartment cover (3) and turn it clockwise.
- Turn the handle (2) and swing the engine compartment cover to the left.

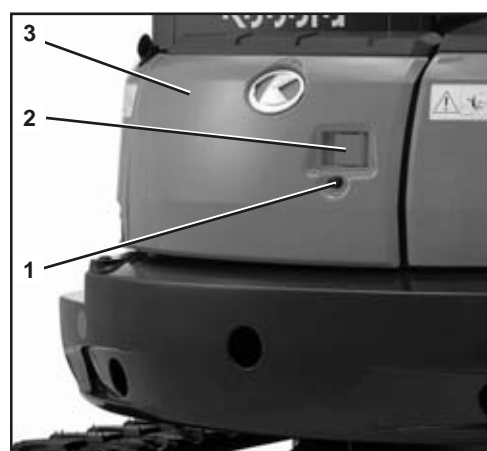

Operation

- Secure the engine compartment cover with the catch (1).



Make sure that the catch has snapped into place properly. If the engine cover is unexpectedly slammed shut, for example by another person or by the wind, serious injury could result.

- To close the engine compartment cover, first lift the catch.
- Close the engine compartment cover and press it into the lock.
- Turn the key anticlockwise to lock the engine compartment cover.
- Pull out the key.

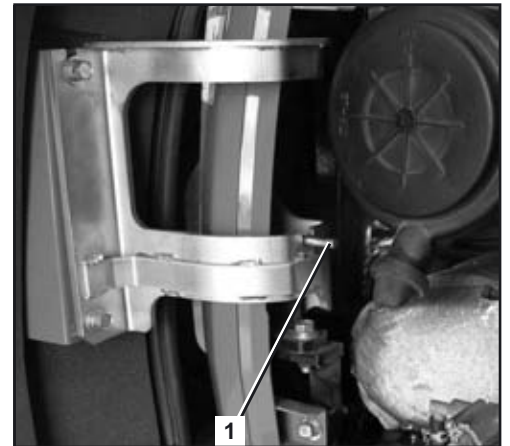

Opening/closing the side cover

- Insert the key in the lock (1) of the side cover (3) and turn it clockwise.
- Pull the handle (2) and swing the side cover all the way up.

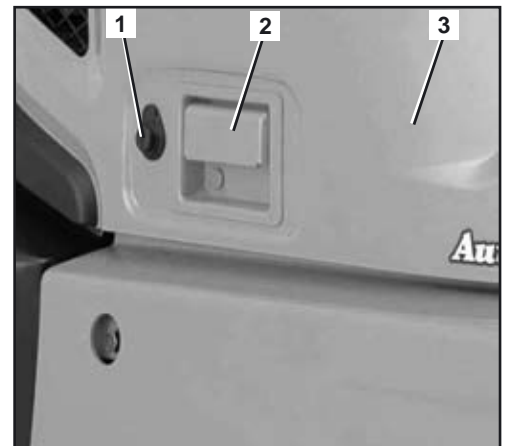

- The catch (1) snaps into place automatically as soon as the side cover is released.



Make sure that the catch has snapped into place properly. If the engine cover is unexpectedly slammed shut, for example by another person or by the wind, serious injury could result.

- To close the side cover, raise it and lift the catch to unlock it.
- Close the side cover and press it into the lock.
- Turn the key anticlockwise to lock the side cover.
- Pull out the key.

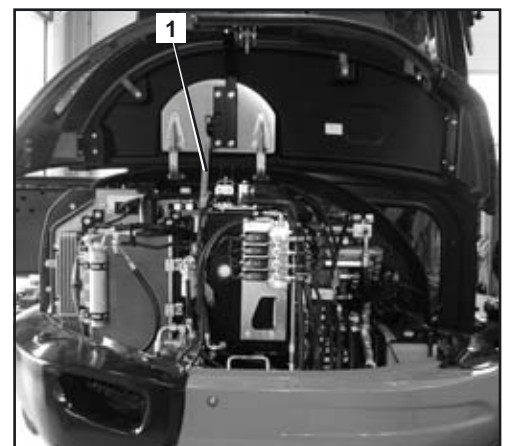

Opening/closing the tool compartment (KX057-4 only)

- Open the side cover (page 111).
- Tilt the lid (1).
- To close, lower the lid again and close the side cover.

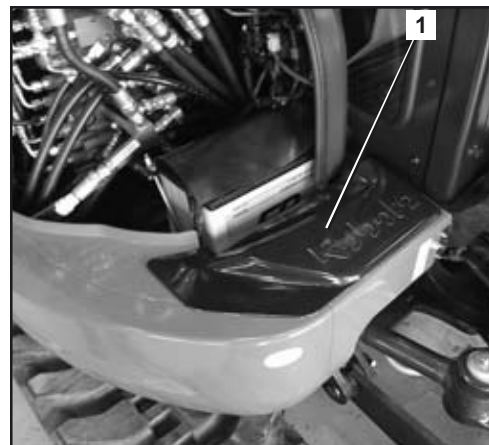

Opening/closing the service covers

Opening/closing the front service covers

- Insert the key in the lock (1) of the cover (2) and turn it clockwise.
- Open the cover.
- To lock the cover, close it again and turn the key anticlockwise.
- Pull out the key.

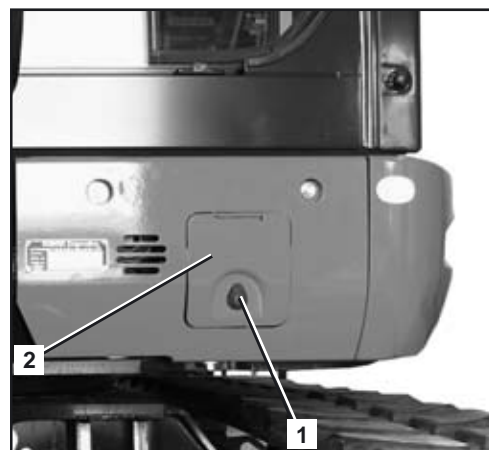

Opening/closing the left service cover (optional KX057-4 only)

- Insert the key in the lock (1) of the cover (2) and turn it clockwise.
- Open the cover.
- To lock the cover, close it again and turn the key anticlockwise.
- Pull out the key.



Replacing the bucket



When replacing the bucket, make sure to wear an eye protection, a helmet and protective gloves.



During attaching and detaching, chippings and burrs may occur at the bolts or bushings. These may cause severe injuries.



Never use your fingers for the alignment of the components (linkage, bucket, arm). The components may sever your fingers by uncontrolled movements.

Anti-theft system

The excavator is equipped with an anti-theft system that restricts the engine to be started using a registered key only. If a registered key gets lost or stolen, you can invalidate it. This will prevent the engine from being started with this key, thus protecting the vehicle against theft. The anti-theft system makes it difficult to steal the machine. However, it can not fully prevent theft.

If the starter switch is set to STOP, the indicator light (1) is illuminated, indicating the activation of the anti-theft system.

Make sure that the indicator light is illuminated when leaving the machine.

If the starter switch with key inserted is set to STOP when leaving the excavator, an acoustic signal will sound as a warning and the message "Pull out key" is shown in the display.

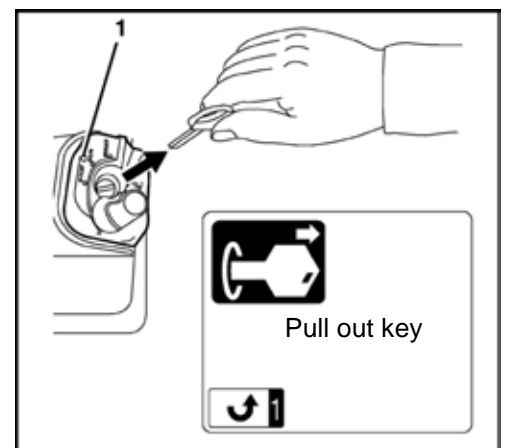

The vehicle comes with two different types of keys:

Black (individual) key

- This key is used to start the engine.
- The engine can be started by inserting the key and turning it to the START position.
- To be able to start the engine with a black key, it must be registered using the red key.

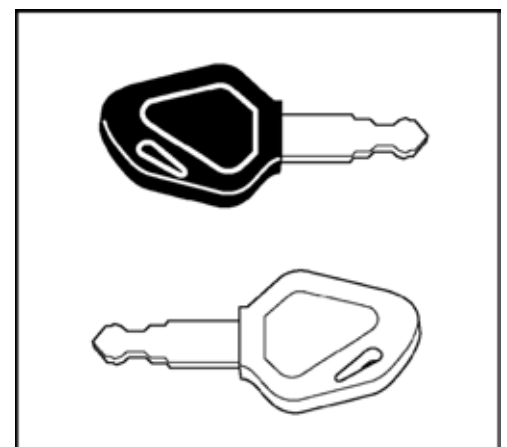

The engine can be started only with a key that was registered for the particular vehicle. The scope of delivery includes two black keys, among them a spare key. The two black keys have already been registered. Up to four keys can be registered.

Red key (for registering)

- If one of the black keys is lost, another black key can be registered using the red key (page 115).
- The engine can not be started with the red key.

The key system

- If a registered key is lost, the second and new black key must be re-registered. This procedure locks the lost or stolen black key, which can no longer be used to start the engine.
- If the red key is lost, the black keys can no longer be re-registered. Be sure to keep the red key in a secure location (such as a safe in the office). Never leave the key inside the machine. If it should get lost nevertheless, please contact your authorised dealer immediately.
- If six times attempts are made within one minute to turn the starter switch to the START position with a wrong or unregistered key, an acoustic signal will sound for 30 seconds. The signal will continue to sound even if the starter switch is turned to the STOP position again or the key is removed within this time period. When a key registered for this machine is inserted into the starter switch, the acoustic signal will be turned off.
- Do not use several of these keys in a bunch. This could lead to electrical interfering frequencies which might prevent the motor from starting.
- Use only the special KUBOTA key ring. Other key rings can lead to signal failures between the key and starter switch, and the engine can possibly not start or a key registration cannot be performed.
- After receiving the set of keys, separate them from each other. Always make sure the keys are not part of a bunch. If one of the black keys, for example, is inserted into the starter switch, the red key might be detected by the electronic system. This might lead to a failure of the electronic system.
- If machine malfunctions occur, please contact your Kubota dealer immediately in order to have the malfunction localised and remedied.
- Messages in the display can be shown in 11 languages. Your KUBOTA dealer can assist you in your language selection.
- If you erroneously attempt to register a black key that has already been registered, the display will show the "Pull out key" message and registration cannot be carried out.

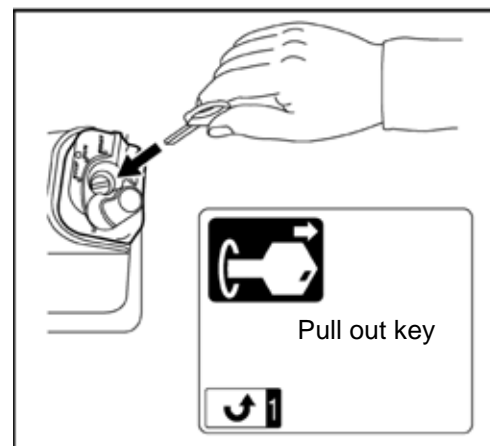

Operation

- If you attempt to register a fifth black key, the display will show the "Stop Register" message and registration cannot be carried out.

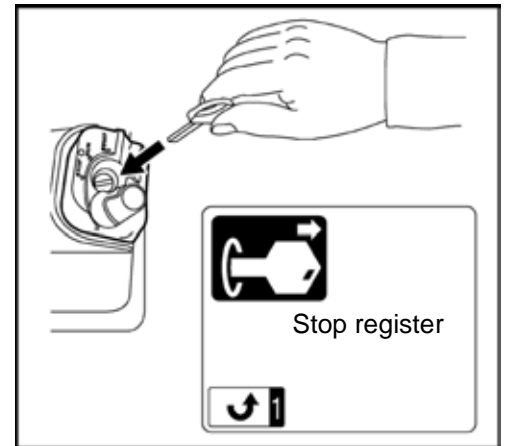

Registering a black key for the machine



Register a black key only under the following conditions:

Make sure that there are no persons within the excavator's working area. It is essential to warn persons in the vicinity of the excavator by briefly honking the horn.

Make sure that all operational controls are in the neutral position.

Starting the excavator is only allowed when the operator is sitting on the operator's seat.

Do not allow the engine to run indoors, unless the room is equipped with an exhaust gas extraction system or otherwise well ventilated. The exhaust gas contains carbon monoxide, a colourless, odourless, and lethal gas.

1. Insert red key into the starter switch.



Do not turn the key at this point. If the key is in the RUN position, turn it back to the STOP position.

2. Press the display selector switch (button 5).
3. The display shows the "Pull out key" message.

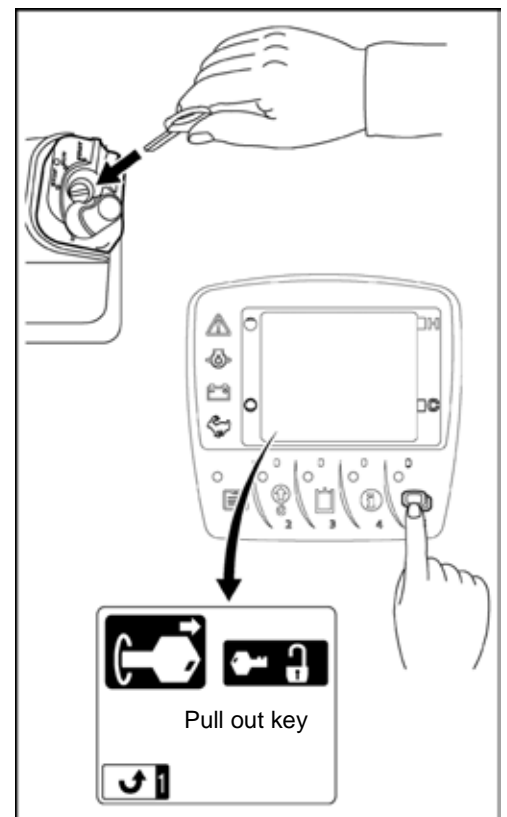

4. Pull out the red key.
5. The display shows the "Insert key" message.
6. Insert black key into the starter switch.



Do not turn the key at this point. If the key is in the RUN position, turn it back to the STOP position.

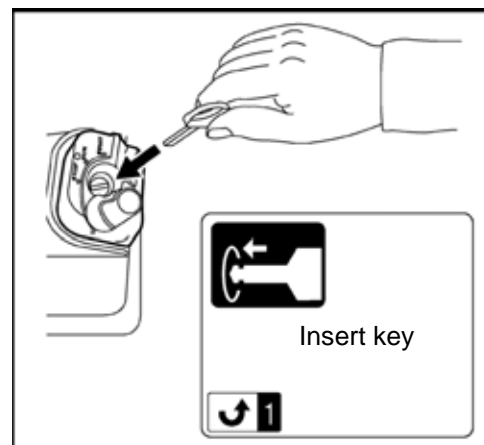

7. After a brief moment, the display shows the "Pull out black key" message. This message indicates that the black key was registered for the given vehicle.

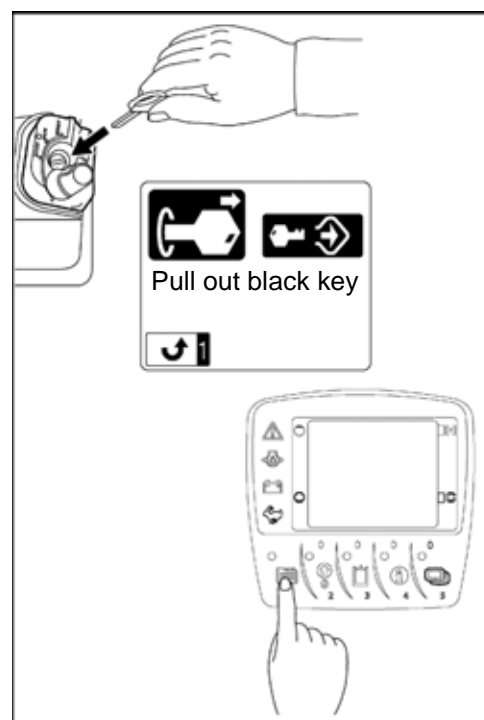

8. Press the menu button (button 1) to complete registration.
9. One after the other, insert all registered black keys into the starter switch and check whether the engine can be started using these keys.



If a registered black key is lost, the other black keys must be re-registered. This procedure locks the lost or stolen black key, which can no longer be used to start the engine.

Troubleshooting

The troubleshooting section includes only malfunctions and incorrect operations which must be remedied by the operator. Any other malfunctions may only be eliminated by trained personnel. The troubleshooting must be performed with the aid of the troubleshooting table. In order to locate a malfunction, first look in the MALFUNCTION column for the corresponding excavator malfunction. In the POSSIBLE CAUSE column you will find the possible causes for the malfunction. The REPAIR column indicates the required remedial measure. If the fault can not be remedied by the measure indicated in the REPAIR column, consult trained personnel.

Safety rules for troubleshooting

Adhere to the general safety rules (page 14 and the safety rules for operation (page 57)).

The operator is not allowed to open the electrical and hydraulic system. These services are reserved for trained personnel.

During troubleshooting, the safety on and around the excavator must always be ensured.

If troubleshooting of the excavator calls for the bucket being raised, the operator may not stand in the area of the front attachments unless the front attachments are secured against inadvertent lowering by suitable measures.

Troubleshooting: Before operation

MALFUNCTION	POSSIBLE CAUSE	REPAIR
Start-up		
No function available when the starter switch is turned to the RUN position	Main fuse at battery defective	Replace the main fuse (page 110).
Indicator lights do not come on as expected when the starter switch is turned to the RUN position	Defective fuse	Replace the fuses (page 108).
Starter does not turn when the starter switch is turned to the START position	Battery depleted	Charge the battery (page 144). Jump-starting the excavator (page 103).
	Engine stop knob pulled	Push the engine stop knob (page 26).
	Control lever lock not raised	Raise the control lever lock.
Engine does not start when the starter switch is turned to the START position, but starter turns	Air in the fuel system	Check the fuel system for leaks and bleed it (page 108).
	Water in the fuel system	Check the water separator for water content, drain water if necessary (page 136).

Troubleshooting: Operation

MALFUNCTION	POSSIBLE CAUSE	REPAIR
Operation		
Exhaust gas colour very black	Air filter restricted	Check, clean and replace the air filter (page 135).
Insufficient engine power	Air filter restricted	Check, clean and replace the air filter (page 135).
	Fuel filter restricted or water in fuel system	Check the water separator for water content. Drain it (page 136) and renew the fuel filter (page 136), if necessary.
Deviation in driving direction of excavator	Crawler tension adjusted incorrectly	Check and adjust the crawler tension, if necessary (page 148).
No pilot-controlled hydraulic functions available	Fuse in fuse box defective	Replace the fuses (page 108).
Power of hydraulic functions is too low or disruptive	Hydraulic oil level too low	Check the hydraulic oil level, add hydraulic oil (page 142).
	Suction filter restricted	Change the suction filter in the hydraulic oil tank (page 141).
Travel speed button does not work	Fuse in fuse box defective	Replace the fuses (page 108).
Heater fan, wiper/washer system, interior light, horn, working light not operating	Fuse in fuse box defective	Replace the fuses (page 108).
Indicator for the AUTO IDLE switch lights up	Fuse in fuse box defective	Replace the fuses (page 108).







Troubleshooting: Display indications



















If the machine develops a fault, one of the following messages will appear on the display. In the event of problems please inform your KUBOTA dealer immediately.

















If the information symbol (i) appears in the display, you can view detailed information by pressing the information button. Inform your KUBOTA dealer which messages appeared in the display.

No.	Display	Problem/Error	Preliminary Measure	Solution
1.	Clock setting request 	Power was interrupted and the clock now has to be set again.	In order to set the clock, press the display selector switch (button 5).	-
2.	Raise the control lever lock 	This message indicates a step in a procedure.	Raise the control lever lock; the indicator goes out.	-
3.	Lower the control lever lock 	This message indicates a step in a procedure.	Lower the control lever lock; the indicator goes out.	-
4.	Start the engine 	This message indicates a step in a procedure.	Start the engine; the indicator goes out.	-
5.	Pull out key 	The key must be pulled out.	Pull out key.	-
6.	Key recognition complete, pull out key. 	The red registration key has been recognized and must now be pulled out.	Pull out the key; the indicator goes out.	-
7.	Insert key 	The keys that are to be registered must be inserted in sequence.	Insert the black key. To cancel registration, press the menu button (button 1).	-

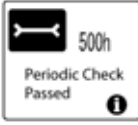
No.	Display	Problem/Error	Preliminary Measure	Solution
8.	Registration complete 	Registration is complete and the black key must now be pulled out.	Pull out the black key.	-
9.	Already registered 	The black key has already been registered.	Pull out the black key and insert a key that has not yet been registered.	-
10.	Stop register 	No more keys can be registered.	Do not register any more keys.	-
11.	Push auxiliary port enable switch 	The auxiliary port function was activated without the auxiliary port being switched on.	Press the auxiliary port enable switch.	-
12.	Not equipped with auxiliary port 2 	Auxiliary port function 2 was activated although no auxiliary port 2 is present.	-	-
13.	Not equipped with overload warning function 	The overload warning switch was pressed although no overload warning device is present.	-	-
14.	Feed fuel 	This message appears when the fuel level is low and prompts the operator to refuel.	-	Refuel the excavator.
15.	Fuel sensor error 	The fuel sensor has developed a fault; the fuel gauge does not appear in the display.	Press the display selector switch (button 5) to return to the default display.	Inform your KUBOTA dealer immediately.

No.	Display	Problem/Error	Preliminary Measure	Solution
16.	<p>Charging system error</p> 	The charging system has developed a fault.	Check the V-belt. When the V-belt is OK, let the engine run until indicator goes out.	If the indicator does not go out, inform your KUBOTA dealer immediately.
17.	<p>Oil pressure too low</p> 	The engine oil pressure is too low.	Stop the engine immediately. The engine may have developed a fault.	Inform your KUBOTA dealer immediately.
18.	<p>Overvoltage</p> 	This is a warning that a higher voltage (from a 24-V battery, for example) is being applied to the electric circuit, or that there is a problem with the alternator.	Switch the engine off immediately and check the battery and the alternator. Restart the engine.	If the indicator lights up again after re-starting, inform your KUBOTA dealer immediately.
19.	<p>Water temperature raising</p> 	The temperature of the coolant is higher than normal.	Operate the machine only with reduced loads until the temperature is normal again.	-
20.	<p>Overheat</p> 	The machine is overheated and must cool off by idling.	Allow the machine to cool off by idling. Do not switch the engine off as the coolant could then boil over.	Clean the radiator and check the coolant, top up if necessary. Check the hydraulic system for leaks; if necessary, inform your KUBOTA dealer.
21.	<p>Water temperature sensor error</p> 	The coolant temperature sensor has developed a fault; the coolant temperature gauge does not appear in the display.	Press the display selector switch (button 5) to return to the default display. The functions of the machine are stable but overheating cannot be excluded.	Inform your KUBOTA dealer immediately.
22.	<p>Lever lock system error</p> 	The electrical system in the control lever lock has developed a fault.	The engine can be started but the machine cannot be set in motion.	Inform your KUBOTA dealer immediately.
23.	<p>Travel speed system error</p> 	The electrical system in the travel speed has developed a fault.	The machine can only be set in motion at low speed.	Inform your KUBOTA dealer immediately.

No.	Display	Problem/Error	Preliminary Measure	Solution
24.	AI system error 	The automatic idle control has developed a system fault.	The idle control is not functioning. Take the machine to the workshop.	Inform your KUBOTA dealer immediately.
25.	External 5- V system error 	The 5-V sensor supply line has developed a system fault. The main functions are not available.	The machine can be started and driven. Do not perform any work with the machine.	Inform your KUBOTA dealer immediately.
26.	External 12- V system error 	The 12-V sensor supply line has developed a system fault. The main functions are not available.	The machine can be started and driven. Do not perform any work with the machine.	Inform your KUBOTA dealer immediately.
27.	CAN System Error 	The Controller Area Network (CAN) has developed a fault. Measured values may be incorrect and switches may not function.	The machine can be started and driven. Do not perform any work with the machine.	Inform your KUBOTA dealer immediately.
28.	Versatile operating switch system error 	The multifunctional switch has developed a system fault.	The machine can be operated but the auxiliary port will not function.	Inform your KUBOTA dealer immediately.
29.	Auxiliary port 1 system error 	Auxiliary port 1 has developed a fault.	The machine can be operated but auxiliary port 1 will not function.	Inform your KUBOTA dealer immediately.
30.	Auxiliary port 2 system error 	Auxiliary port 2 has developed a fault.	The machine can be operated but auxiliary port 2 will not function.	Inform your KUBOTA dealer immediately.
31.	Periodic check soon (notice) 	This message means that the regular service is due shortly.	Operate the machine as usual.	Ask your KUBOTA dealer about the relevant parts. Run the maintenance procedure.

No.	Display	Problem/Error	Preliminary Measure	Solution
32.	Period check passed (warning) 	This message means that the regular service is due.	The machine can be operated but service must be carried out urgently.	Ask your KUBOTA dealer about the relevant parts. Run the maintenance procedure.
33.	Anti-theft system error 	The anti-theft system has developed a system fault.	-	Inform your KUBOTA dealer immediately.
34.	Key recognition 	The key has not been recognized.	The machine cannot be started: if there is more than one key or another metal object on the keyring, remove the key from the ring. If the message does not disappear, it means that the key may be damaged. Try using a spare key.	Remove any other keys and metal objects from the keyring and try again.
35.	Wrong key, unable to start 	The machine cannot be started because the wrong key has been inserted.	Use the correct key.	-
36.	RED registration key, unable to start 	Try starting the engine with the red key (for registration).	Use the correct key.	-
37.	Rated load exceeded 	The load to be lifted is too heavy.	The overload warning applies only to lifting loads. Deactivate the overload warning during other types of work (e.g. excavating) by pressing the overload warning switch (button 2).	Lower the load and reduce its weight.

Maintenance

The "Maintenance" section includes all care and maintenance tasks to be performed on the excavator.

A careful maintenance of the excavator will guarantee functional safety and longer service life.

Neglect of the servicing will void the warranty and any liability by KUBOTA.

Only use spare parts that are recommended by the manufacturer. Non-approved spare parts of inferior quality or wrong classification result in an increased risk of accidents. Operators using non-approved spare parts are fully responsible for any damage arising thereof.

Safety rules for maintenance

- Persons who work with or on the excavator must be provided by the operator with, and where applicable use suitable personal protective equipment (PPE), for example suitable working clothes, safety shoes, safety helmets, eye protection, ear protection and air-filter masks. The owner/employer bears the main responsibility for the PPE, which is specified by the safety rules for particular types of activity.
- Maintenance, cleaning and care activities may only be carried out if the excavator is fully shut down. The excavator must be secured against starting by removal of the key. The bucket must always be lowered to the ground for servicing.
- The bucket must always be lowered to the ground for servicing.
- When defects are detected during servicing or maintenance, the excavator may only be operated after the defects are remedied. Repairs may only be carried out by trained personnel.
- When carrying out maintenance and care activities, always make sure that the excavator is secured and stable.
- When working on the fuel system, smoking, open flames and the operation of other ignition sources are not allowed. The danger zone has to be clearly marked with signs. A fire extinguisher must be kept at hand in the danger zone.
- All waste materials must be discarded in accordance with environmental protection regulations.
- Use the maintenance and care materials listed in the "Recommended lubricants" section (page 157).
- When working on the electrical system, disconnect it from the voltage source before starting the work. The work may only be carried out by technicians with electrical training.
- Always use a ladder or a scaffold if the work cannot be reached by the operator.
- The controls may only be used while the operator is sitting on the operator's seat.

Personnel requirements

- The operator may only carry out cleaning and care activities.
- The servicing may only be performed by trained personnel.

General maintenance chart: 50 to 500 hours of operation

Operator servicing

General maintenance	Elapsed hours of operation										Interval	Page
	50	100	150	200	250	300	350	400	450	500		
Check the fuel level											daily	66
Check the coolant level											daily	63
Checking the engine oil level											daily	62
Check the hydraulic oil level											daily	65
Grease the bucket bolt and bucket linkage bolt											daily	65
Check the V-belt											daily	64
Check the fluid level of the washer system reservoir											daily	105
Check the electric cables and connections											daily	66
Clean the radiator and condenser											daily	130
Lubricate the front-end attachments	Grease the swing bracket										daily	147
	Other greasing points										daily	147
Check the water separator	○	○	○	○	○	○	○	○	○	○	50 h	136
Drain water from the fuel tank	○	○	○	○	○	○	○	○	○	○	50 h	137
Check the battery electrolyte level	○	○	○	○	○	○	○	○	○	○	50 h	144
Grease the swivel gear	○	○	○	○	○	○	○	○	○	○	50 h	146
Crawlers and chassis: Clean, visually inspect and check tension	○	○	○	○	○	○	○	○	○	○	50 h	148
Grease the pitch bearing				○				○			200 h	146
Check, clean the interior air filter 1.)				○				○			200 h	150
Check, clean the air filter 1.)				○				○			200 h	135
Check the coolant hoses and hose clamps				○				○			200 h	131
Check the fuel lines and air intake hoses				○				○			200 h	138
Check the pipes and hoses of the air-conditioner											annually	151

1.) Under very dusty conditions, the air filter and the interior air filter must be cleaned more frequently or replaced.

General maintenance chart: 550 to 1000 hours of operation

Operator servicing

General maintenance	Elapsed hours of operation										Interval	Page
	550	600	650	700	750	800	850	900	950	1000		
Check the fuel level											daily	66
Check the coolant level											daily	63
Checking the engine oil level											daily	62
Check the hydraulic oil level											daily	65
Grease the bucket bolt and bucket linkage bolt											daily	65
Check the V-belt											daily	64
Check the fluid level of the washer system reservoir											daily	105
Check the electric cables and connections											daily	66
Clean the radiator and condenser											daily	130
Lubricate the front-end attachments	Grease the swing bracket										daily	147
	Other greasing points										daily	147
Check the water separator	○	○	○	○	○	○	○	○	○	○	50 h	136
Drain water from the fuel tank	○	○	○	○	○	○	○	○	○	○	50 h	137
Check the battery electrolyte level	○	○	○	○	○	○	○	○	○	○	50 h	144
Grease the swivel gear	○	○	○	○	○	○	○	○	○	○	50 h	146
Crawlers and chassis: Clean, visually inspect and check tension	○	○	○	○	○	○	○	○	○	○	50 h	148
Grease the pitch bearing		○				○			○		200 h	146
Check, clean the interior air filter 1.)		○				○			○		200 h	150
Check, clean the air filter 1.)		○				○			○		200 h	135
Check the coolant hoses and hose clamps		○				○			○		200 h	131
Check the fuel lines and air intake hoses		○				○			○		200 h	138
Check the pipes and hoses of the air-conditioner											annually	151

1.) Under very dusty conditions, the air filter and the interior air filter must be cleaned more frequently or replaced.

Servicing maintenance chart: 50 to 500 hours of operation

Servicing by skilled personnel or KUBOTA dealer

Servicing	Elapsed hours of operation *										Interval	Page	
	50	100	150	200	250	300	350	400	450	500			
Check the coolant hoses and hose clamps					○						○	250 h	131
Check and adjust the V-belt					○						○	250 h	131
Change the engine oil and oil filter											○	500 h	133
Replace the drive unit oil 3.)	●										○	500 h	150
Replace the fuel filter											○	500 h	136
Replace the tank breather filter											○	500 h	139
Replace the return filter 2.)												1000 h	138
Replace the pilot circuit filter												1000 h	140
Change the hydraulic oil and replace the suction filter 2.)												1000 h	141
Replace the air filter elements 1.)												1000 h	135
Replace the interior air filter 1.)												1000 h	150
Change the oil of the idler and track roller	Please contact your KUBOTA dealer.										2000 h	--	
Check alternator and starter motor	Please contact your KUBOTA dealer.										2000 h	--	
Safety inspection 4.)												annually	159
Replace the coolant hoses and hose clamps	Please contact your KUBOTA dealer.										every 2 years	--	
Replace the fuel lines and air intake hoses	Please contact your KUBOTA dealer.										every 2 years	--	
Replace the pipes and hoses of the air-conditioner	Please contact your KUBOTA dealer.										every 2 years	--	
Replace the coolant												every 2 years	
Replace the hydraulic hoses	Please contact your KUBOTA dealer.										every 6 years	--	
Check the refrigerant content												maintenance on demand	152

* The servicing identified with ● must be carried after the specified hours of operation after initial operation have been reached.

- 1.) Under very dusty conditions, the air filter and the interior air filter must be cleaned more frequently or replaced.
- 2.) When using a breaker over 20 % → every 800 h.
 When using a breaker over 40 % → every 400 h.
 When using a breaker over 60 % → every 300 h.
 When using a breaker over 80 % → every 200 h.
- 3.) Earlier if necessary.
- 4.) At least annually.

Servicing maintenance chart: 550 to 1000 hours of operation

Servicing by skilled personnel or KUBOTA dealer

Servicing	Elapsed hours of operation										Interval	Page	
	550	600	650	700	750	800	850	900	950	1000			
Check the coolant hoses and hose clamps					○						○	250 h	131
Check and adjust the V-belt					○						○	250 h	131
Change the engine oil and oil filter											○	500 h	133
Replace the drive unit oil 3.)											○	500 h	150
Replace the fuel filter											○	500 h	136
Replace the tank breather filter											○	500 h	139
Replace the return filter 2.)											○	1000 h	138
Replace the pilot circuit filter											○	1000 h	140
Change the hydraulic oil and replace the suction filter 2.)											○	1000 h	141
Replace the air filter elements 1.)											○	1000 h	135
Replace the interior air filter 1.)											○	1000 h	150
Change the oil of the idler and track roller	Please contact your KUBOTA dealer.										2000 h	--	
Check alternator and starter motor	Please contact your KUBOTA dealer.										2000 h	--	
Safety inspection 4.)												annually	159
Replace the coolant hoses and hose clamps	Please contact your KUBOTA dealer.										every 2 years	--	
Replace the fuel lines and air intake hoses	Please contact your KUBOTA dealer.										every 2 years	--	
Replace the pipes and hoses of the air-conditioner	Please contact your KUBOTA dealer.										every 2 years	--	
Replace the coolant												every 2 years	132
Replace the hydraulic hoses	Please contact your KUBOTA dealer.										every 6 years	--	
Check the refrigerant content												maintenance on demand	152

- 1.) Under very dusty conditions, the air filter and the interior air filter must be cleaned more frequently or replaced.
- 2.) When using a breaker over 20 % → every 800 h.
 When using a breaker over 40 % → every 400 h.
 When using a breaker over 60 % → every 300 h.
 When using a breaker over 80 % → every 200 h.
- 3.) Earlier if necessary.
- 4.) At least annually.

Cleaning the excavator



Before cleaning, shut down the engine and secure it against starting.



If a steam cleaner is used for cleaning the excavator, do not direct the steam jet at electric components.



Do not direct a water jet into the intake opening of the air filter.



Do not clean the excavator with inflammable liquids.



The excavator may only be washed at suitable places (using oil and grease separators).

The excavator can be cleaned with water and a commercial cleaning agent. Make sure no water gets into the electrical system.

Use a plastic cleaner for plastic parts.

Before cleaning, make sure to tape the air inlet for the air-conditioner and heater system at the swivel frame.

Servicing

Adhere to the instructions for regular servicing to keep the excavator in good condition.

Refilling coolant

- Open the engine compartment cover (page 110).
- Check the antifreeze content with an antifreeze tester that is qualified for -25 °C.



The antifreeze portion of the coolant should not exceed 50 %.

- Open the coolant expansion reservoir cap when the engine is cool and fill pre-mixed coolant up to the FULL mark (1).
- Close the expansion tank cover.
- Close the engine compartment cover.

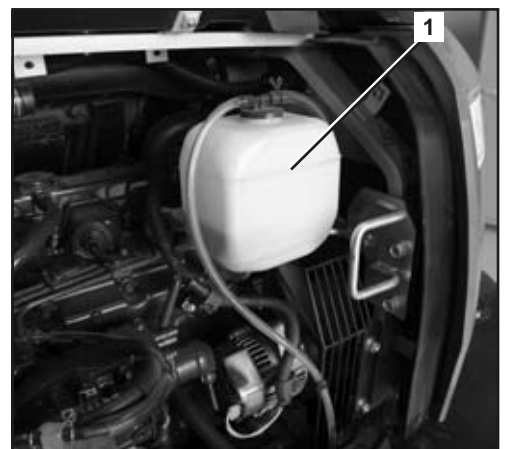

If the coolant expansion reservoir was completely empty, check the coolant level in the radiator.



Do not open the radiator cap while the engine is still hot, risk of scalding.

- Open the side cover (page 111).
- Remove the radiator cap (1) by turning it anticlockwise.
- The coolant level should be at the lower mark of the filler plug; if not, add coolant.
- Close the radiator cap.
- Close the side cover.

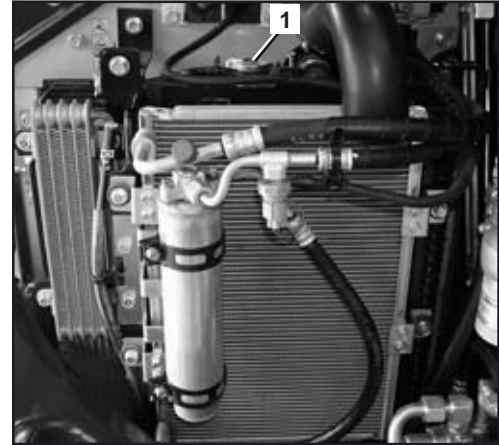

Cleaning the radiators and the condenser



Do not touch the hot radiators: risk of burning.

- Open the side cover (page 111).
- Remove the screws (1).
- Tilt the radiator (2) forwards.
- Swing the catch (3) forwards and snap it into place.
- Clean the coolant radiator (1), hydraulic oil radiator (3), fuel cooler (2) and condenser (4) from the engine side with a water jet or a compressed air pistol. Do not use high-pressure cleaners.
- Pay particular attention to the space between the radiators and the condenser, as leaves tend to accumulate here.

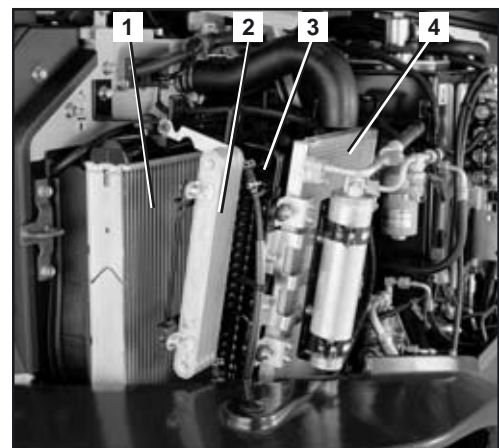
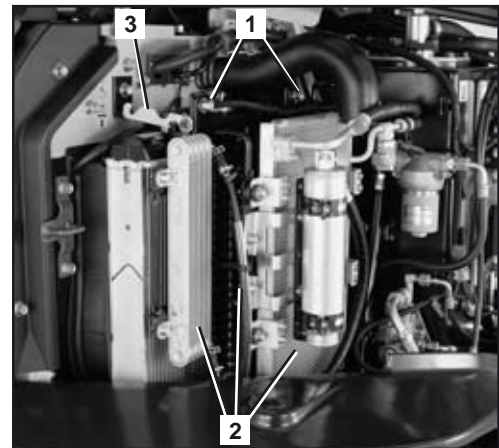

Check the radiator and condenser for damage after cleaning it.

- Swing the catch back again.
- Tilt the radiator back again.
- Refit the screws.
- Close the side cover.

Maintenance

Checking, adjusting and replacing the V-belts

Adjusting the V-belts

- Open the engine compartment cover (page 110).
- Check the V-belt (page 131).
- Remove the mounting screws (2).
- Tighten the V-belts by adjusting the tension roller (1).
- Press in the V-belt (3) at position "A". The V-belt must give way for approx. 7 – 9 mm (pressure: 6 – 7 kg).
- Tighten the fastening screws.
- After adjusting, check the V-belt.

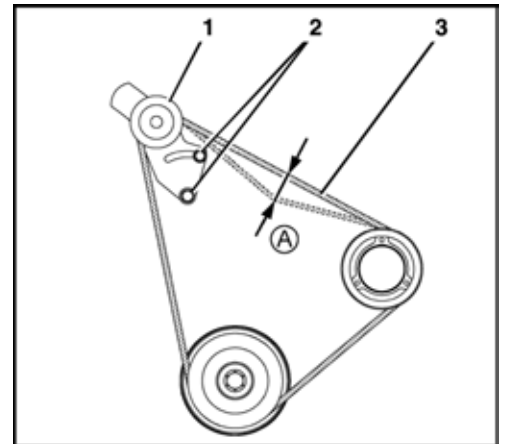

- Remove the mounting screws (2).
- Tighten the V-belt by swinging the alternator (1).
- Press in the V-belt (3) at position "A". The V-belt must give way for approx. 12 – 15 mm (pressure: 7 kg).
- Tighten the fastening screws.
- After adjusting, check the V-belt.
- Close the engine compartment cover.

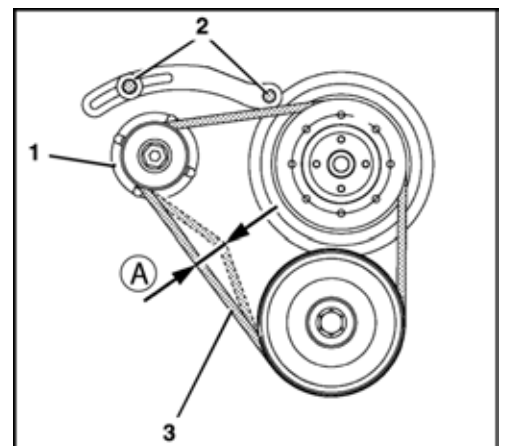

Checking the coolant hoses



Carry out the inspection while the engine is cold.

- Open the engine compartment cover (page 110).

Inspect all hose connections on the engine and to the radiator or to the heater fan for condition (cracks, bulges, hard spots), tightness and firm seating of the clamps. If necessary, have the hoses replaced by trained personnel.

- Close the engine compartment cover.

Replacing the coolant



Drain the coolant only when the engine is cold.

Total cooling system capacity: 8.1 L

- Open the engine compartment and side cover (page 110).
- Remove the radiator cap (1) by turning it anticlockwise.

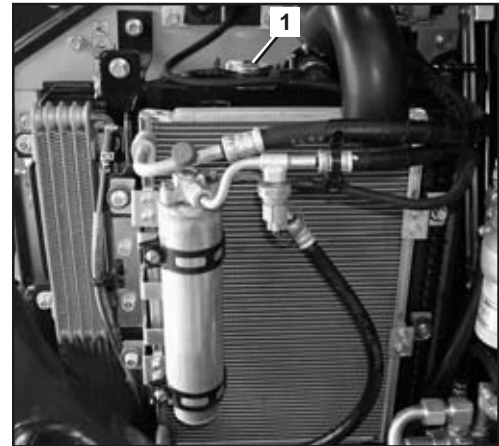

- Open the central coolant drain plug (1) and drain the coolant completely.



Fill the coolant in a container and dispose of it in accordance with the prevailing environmental protection regulations.

Purge the cooling system if the coolant is very dirty. To do this, spray water without additives into the cooling system with a hose through the filler opening until clear water emerges at the outlet.

- Close the central drain.
- Remove the coolant expansion reservoir (1) and drain it, cleaning it if necessary. Refit the reservoir.
- Fill the premixed coolant into the radiator and expansion reservoir.

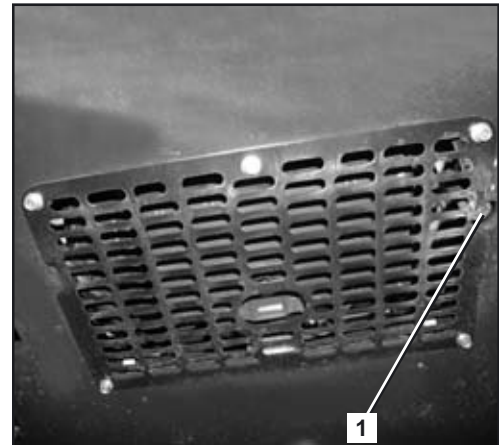

Do not operate the cooling system with pure water (even in summer). The antifreeze also contains a corrosion inhibitor.

- Start the engine (page 69) and let it run at idle speed to warm up.
- Stop the engine (page 70).
- Check the coolant level (page 63), adding coolant if necessary (page 129).
- Close the engine compartment and side cover.

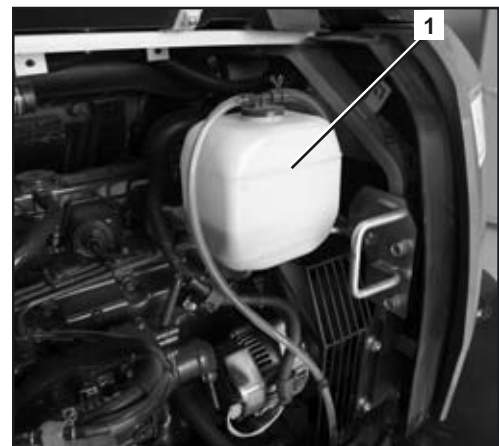

Replacing the engine oil and oil filter

- Open the engine compartment cover (page 110).



The engine oil change must be carried out while the engine is warm.



Caution: The engine oil and the oil filter are very hot → risk of scalding.



Place an oil pan with a capacity of about 15 L under the engine oil drain. The engine oil should not be allowed to seep into the soil and it must be discarded like the oil filter in accordance with the applicable environment protection regulations.

Draining the engine oil

- Remove the oil drain plug (1) and let the engine oil drain into the drain pan.
- Install the oil drain plug using a new seal.

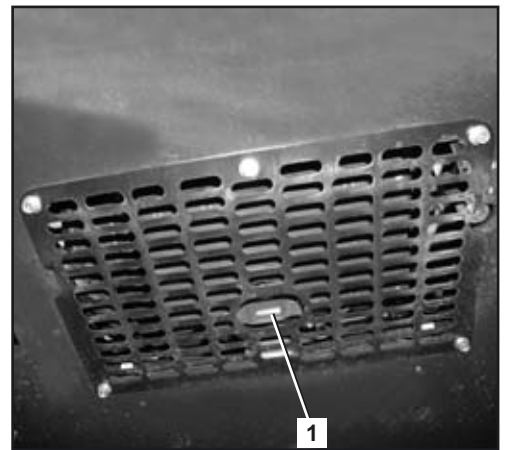

Replacing the oil filter

- Place an oil pan under the oil filter (1). Remove the oil filter using a filter wrench (turn anticlockwise).
- Coat the sealing ring of the new oil filter with engine oil.
- Install and tighten the oil filter by hand. Do not use the filter wrench.

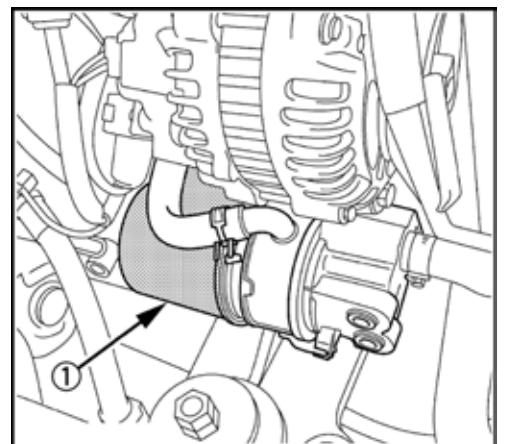

Filling the engine oil

Filling capacity: 9.0 L

- Remove the oil filler cap (2) and fill engine oil. See the "Recommended lubricants" section (page 157).
- Screw in the oil filler cap.
- Start the engine (page 69). The engine oil pressure indicator must go out as soon as the engine has started. If this does not happen, switch the engine off immediately and contact trained personnel.
- Let the engine run at idle speed to warm up, then stop it (page 70). Check the oil level after 5 minutes.
- Pull out the oil dipstick (1) and wipe it with a clean cloth.
- Insert the oil dipstick completely and pull it out again. The oil level should be in the "A" area. If the oil level is too low, add engine oil.

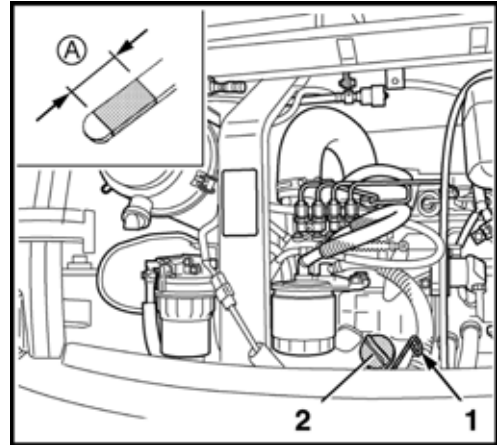

When the oil level is too high or too low, the engine might get damaged during operation.

- When changing the engine oil, fill engine oil up to the MAX mark.
- Close the engine compartment cover.

Checking, cleaning and replacing the air filter



If the excavator is operated in a particularly dusty environment, the air filter must be checked more often.

- Open the engine compartment cover (page 110).
- Open the clips (2) and remove the cover (1).

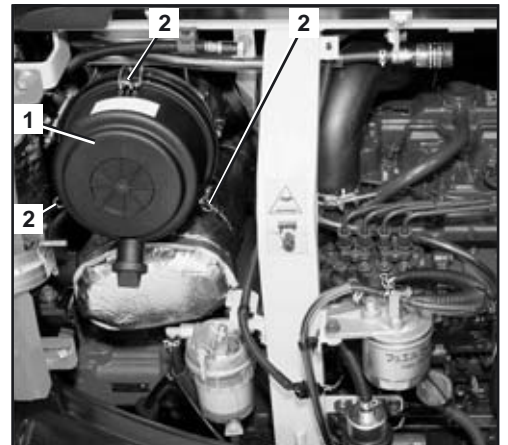

- Pull the outer filter element (1) out of the air filter case (3) and check it for dirt.
- Clean the air filter case and cover without removing the inner filter element (2). Remove the inner filter element only when replacing it.
- Replace the outer filter element if it is damaged or too much dust has accumulated on it.

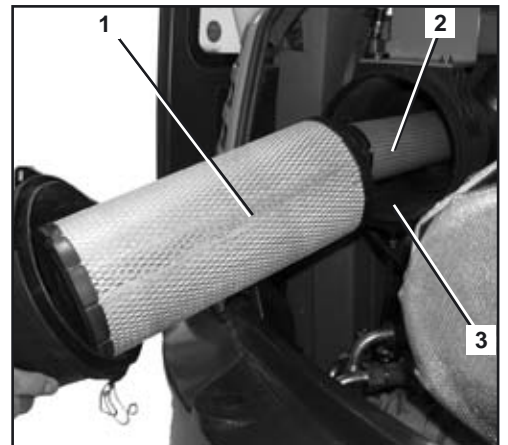

Do not clean the filter element with fluids. Never operate the engine without the air filter elements.



Always wear eye protection when working with compressed air.

- Clean the outer filter element with compressed air (max. 5 bar) from the inside out without damaging the filter element. Wear eye protection for this service.
- Insert the outer air filter element and the cover with the TOP mark up. Then lock the braces.
- Close the engine compartment cover.

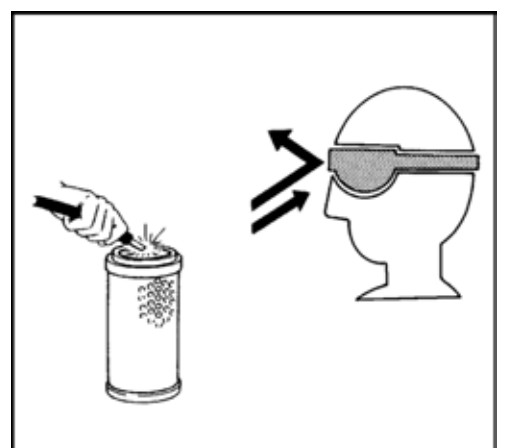

Replacing the fuel filter

- Open the engine compartment cover (page 110).
- Turn the cock (1) at the water separator to the OFF position.
- Remove the fuel filter (2).
- Wet the rubber seal of the new filter with fuel.
- Install a new filter and tighten it by hand.
- Set the cock to the ON position.
- Bleed the fuel system (page 108).
- Check the fuel filter for leaks.



Dispose of cleaning cloths according to the applicable environmental protection regulations.

- Close the engine compartment cover.

Checking and emptying the water separator



Water and impurities in the fuel settle in the water separator (1). A red plastic ring (2) in the water separator floats on the water. The water separator must be emptied if such substances have settled or the plastic ring floats.

- Open the engine compartment cover (page 110).
- Visual inspection of the water separator for water and sediments.



Place a cleaning cloth under the water separator to prevent fuel from running onto the ground.

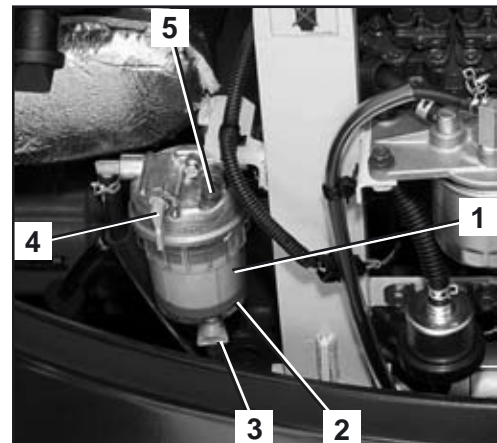

- Turn the cock (4) to the OFF position.
- Loosen the venting screw (5).
- Loosen the drain valve (3) and drain the impurities.
- Close the drain valve.
- Tighten the venting screw.
- Set the cock to the ON position.
- Bleed the fuel system (page 108).
- Check the water separator for leaks.
- Discard the cleaning cloths in an environmentally suitable way.
- Close the engine compartment cover.

Cleaning the water separator

- Open the engine compartment cover (page 110).



Place a cleaning cloth under the water separator to prevent fuel from running onto the ground.

- Turn the cock (1) to the OFF position.
- Remove the filter cup (2).
- Empty the filter cup and clean it with clean diesel fuel.
- Install the filter cup and tighten it by hand.
- Set the cock to the ON position.
- Bleed the fuel system (page 108).
- Check the water separator for leaks.

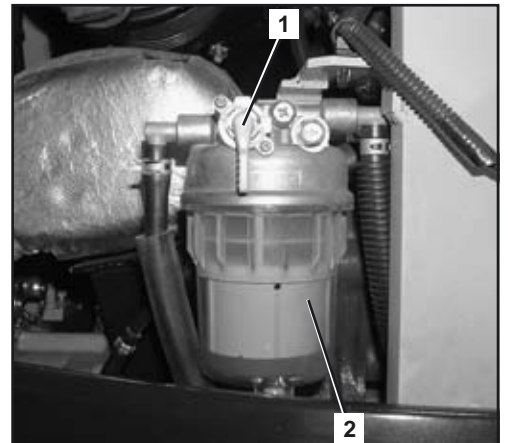

Dispose of cleaning cloths according to the applicable environmental protection regulations.

- Close the engine compartment cover.

Draining the fuel tank

- Open the front service cover (page 112).
- Place a container with a minimum capacity of 12 litres under the fuel drain valve.
- Open drain valve (1) and drain the water.
- Close the drain valve.



Dispose of fluid in the container according to the applicable environmental protection regulations.

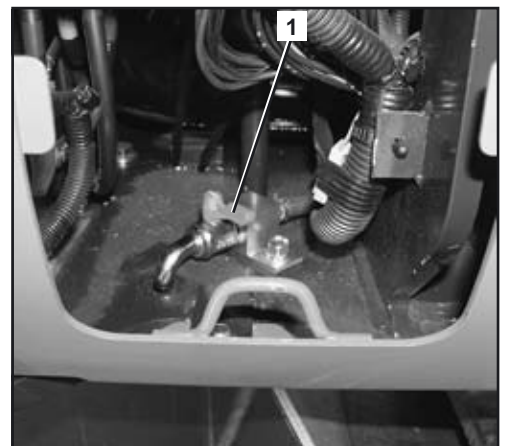

Checking the fuel lines and the air intake hoses

- Check all accessible fuel lines (1), air intake hoses (2) and clamps (3) to ensure that they are not damaged and are firmly seated.
- Repair or replace damaged parts.

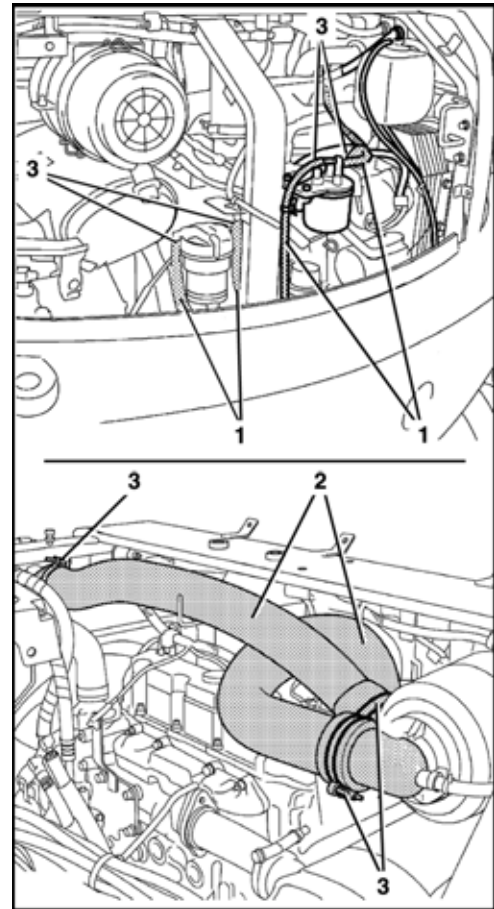

Replacing the return filter in the hydraulic oil tank



Pay attention to utmost cleanliness when servicing the hydraulic system.



This service may only be carried out after the hydraulic oil has cooled down.

- Open the side cover (page 111).
- Remove the screws (1).
- Remove the hydraulic oil tank cover (2).

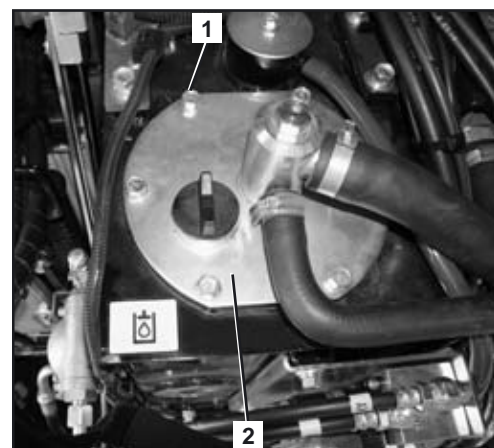

Maintenance

- Remove the return filter (3) with rod (5).
- Loosen the screw (4).
- Remove the return filter and replace it with a new one.



Discard the return filter in accordance with the prevailing environmental protection regulations.

- Tighten the screw (4).
- Check the condition of the sealing ring of the hydraulic oil tank cover. Replace it if necessary.
- Insert the return filter with rod.
- Screw on the hydraulic oil tank cover.
- Close the side cover.

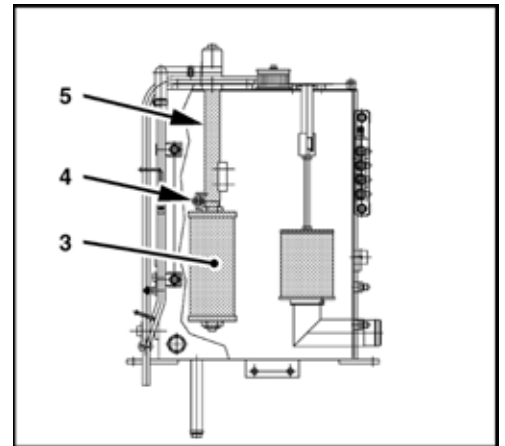

Replacing the tank breather filter



Pay attention to utmost cleanliness when servicing the hydraulic system.



This service may only be carried out after the hydraulic oil has cooled down.

- Open the side cover (page 111).
- Remove the screws (1).
- Remove the cover (2) along with the breather filter (3).
- Take the breather filter out of the cover and replace with a new one.

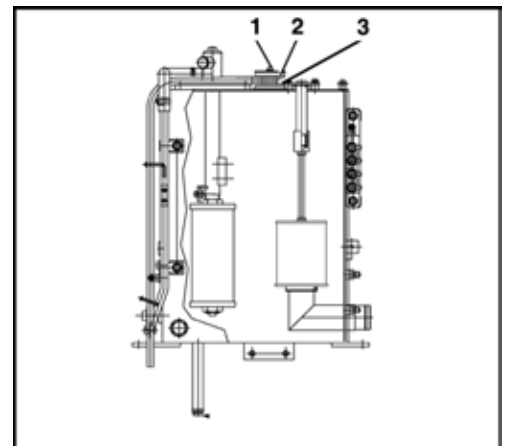

Discard the breather filter in accordance with the valid Resource Conservation and Recovery Act (RCRA).

- Install the cover and breather filter and tighten the screws.
- Close the side cover.

Replacing the pilot circuit filter

- Open the side cover (page 111).
- Remove the filler plug (1) from the hydraulic oil tank.
- Remove the filter cup (2) from the filter head (1).
- Remove the filter element (1) from the filter head.
- Install a new filter along with the included new sealing ring.
- Screw in the filter cup and tighten it by hand.
- Refit the plug of the hydraulic oil tank.
- Start the engine (page 69). Let the engine run at idle speed to warm up, then stop it (page 70).
- Check the hydraulic oil level, add oil if necessary.
- Close the side cover.

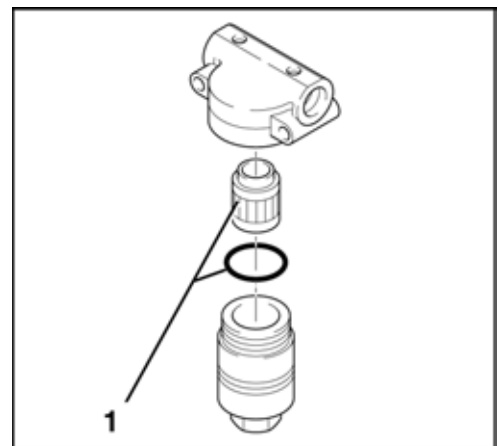
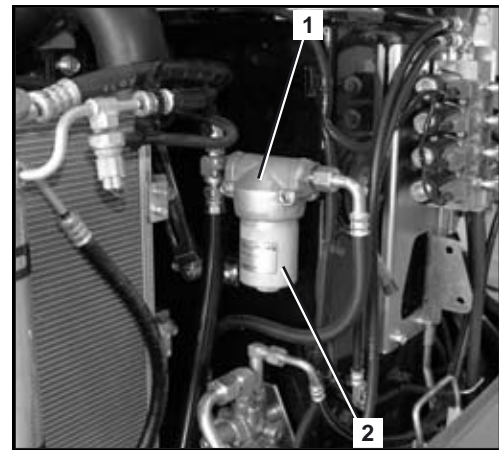
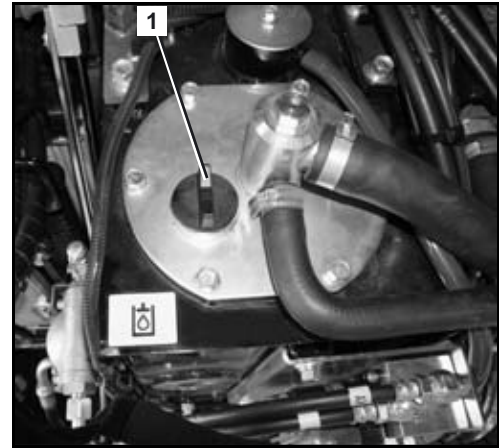

Maintenance

Replacing the suction filter in the hydraulic oil tank



Pay attention to utmost cleanliness when servicing the hydraulic system.



This service may only be carried out after the hydraulic oil has cooled down.



The suction filter must be replaced along with the hydraulic oil.

- Open the side cover (page 111).
- Drain the hydraulic oil (page 142).
- Remove the return filter from the hydraulic oil tank (page 138).
- Remove the screws (3) and take out the rod (1).
- Remove the suction filter assembly (2).
- If necessary, remove any residues with a clean, lint-free cloth.



Discard the suction filter and cleaning cloth in accordance with applicable environmental protection regulations.

- Insert the new suction filter assembly.
- Insert the return filter (page 138).
- Fit the hydraulic oil tank cover with the new seal and tighten it using the hex bolts.
- Fill hydraulic oil (page 143).
- Close the side cover.

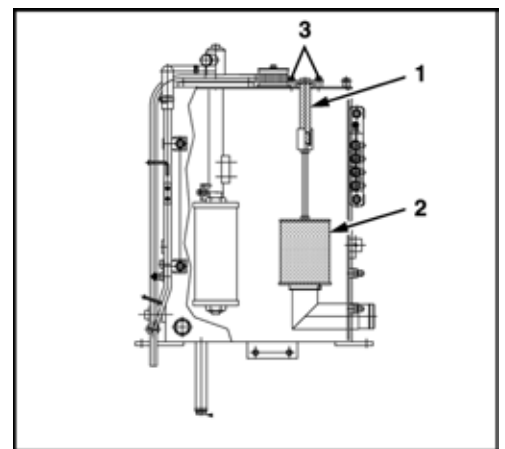

Topping up/changing the hydraulic oil



Pay attention to utmost cleanliness when servicing the hydraulic system.



This service may only be carried out after the hydraulic oil has cooled down.



The suction filter must be changed along with the hydraulic oil.

- Operate the boom, arm, bucket and boom swing mechanism so that all hydraulic cylinders are extended half way. Lower the dozer onto the ground. See the "Placing out of operation" section (page 95).
- Open the side cover (page 111).

Draining the hydraulic oil



The swivel frame must be turned 90° to the right for the hydraulic oil drain to be accessed.

- Place a container with a minimum capacity of 100 litres under the hydraulic oil drain plug.
- Remove the drain plug (1) and drain the hydraulic oil.
- Install the drain plug with a new sealing ring.

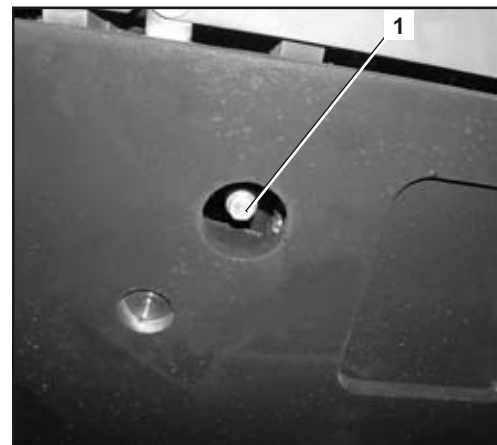

Maintenance

Filling the hydraulic oil

Filling quantity with oil change: approx. 45 L

Total hydraulic system capacity: 79 L

- Remove the filler plug (1) from the hydraulic oil tank.
- Insert a clean funnel with a strainer into the filler plug opening.

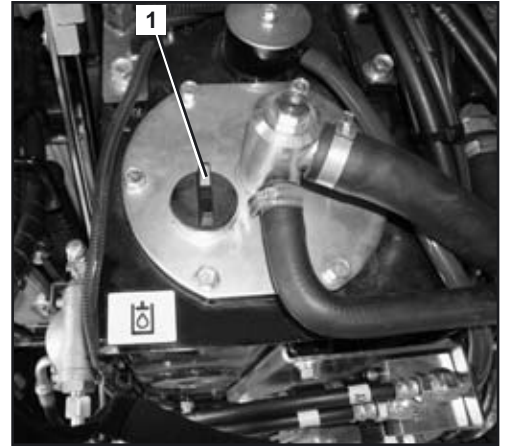

- Fill hydraulic oil to half way up the sight glass (1).
- Refit the plug of the hydraulic oil tank.
- Start the engine (page 69) and operate all control functions.
- Operate the boom, arm, bucket and boom swing mechanism so that all hydraulic cylinders are extended half way. Lower the dozer onto the ground. See the "Placing out of operation" section (page 95).
- Check the hydraulic oil level, add oil if necessary.
- Close the side cover.

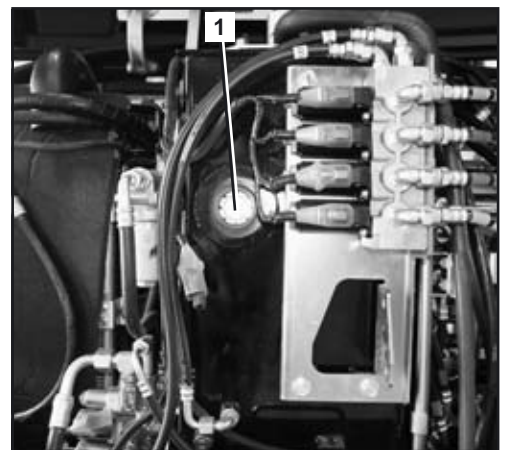

Battery service

Regular maintenance can extend the life cycle of the battery considerably.



When servicing a battery, always wear suitable protective gloves and eye protection.

Checking the battery

- Open the side cover (page 111).

The battery liquid level must be between the LOWER LEVEL (6) and UPPER LEVEL (5) markings. Top up with distilled water if necessary.



Do not open maintenance-free batteries!

- Check that the battery (1) is firmly seated, tighten with nuts (3) if necessary.

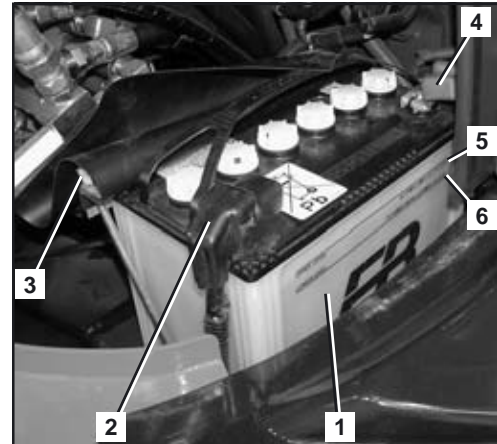

Be careful when cleaning the positive terminal - risk of short circuit! Do not use metal tools.

- Check the battery terminal (previous figure/2 and 4) for cleanliness, cleaning it if necessary and covering it with petroleum jelly.
- Close the side cover.

Charging the battery



Battery acid is very caustic. Avoid contact with battery acid under all circumstances. If clothing, skin or eyes have come in contact with battery acid, rinse the affected parts immediately with water. If the eyes are affected, immediately seek medical attention! Neutralise spilled battery acid immediately.



When servicing a battery, always wear suitable protective gloves and eye protection.



Charge batteries only in sufficiently ventilated rooms. Smoking, uncovered lights or fire are not allowed in these rooms.



Explosive gas is created when charging batteries. Open flames can cause an explosion.



Remove the fill caps when charging batteries that are virtually empty. Leave the fill caps inside (not empty) batteries that are only charged for maintenance purposes, the fill caps can stay in the batteries.



The battery can only be charged if the starter switch is in the STOP position and the key removed.

- Make the battery accessible.
- Check the electrolyte level in the battery, adding distilled water if required.



When disconnecting and connecting the battery, always observe the specified order → risk of short circuit.

- Remove the negative terminal cover and take off the cable clamp. Put the clamp to the side so that contact with the negative terminal is excluded.
- Remove the positive terminal cover.
- Connect the battery charger to the battery according to the instructions of the charger manufacturer. Choose the normal (gentle) charging method.
- Clean the battery after charging and replenish the electrolyte, if necessary.
- Check the acid density with a hydrometer. The acid density should be between 1.24 and 1.28 kg/L. If the acid density differs considerably among the individual cells of a battery, the battery probably has a defect. Check the affected battery with a battery tester and contact trained personnel.

Installing/uninstalling and replacing the battery



When disconnecting and connecting the battery, always observe the specified order → risk of short circuit.

- Make the battery accessible.
- Remove the negative terminal cover and take off the cable clamp. Put the clamp to the side so that contact with the negative terminal is excluded.
- Remove the plus terminal cover and take off the cable clamp. Put the clamp to the side so that contact with the positive terminal is excluded.
- Remove the battery retainer and lift the battery out of the swivel frame.



When replacing the battery, always install a battery of the same type with the same power rating and the same dimensions.

- Before installation, cover the battery terminals and cable clamps with petroleum jelly.
- Install the battery in the swivel frame and fasten it with the battery retainer. Check the battery for tightness → Do not operate the excavator with a loose battery.
- Connect the positive cable clamp to the positive terminal (+) of the battery, install the positive terminal cover.
- Connect the negative terminal (-) of the battery, install the negative terminal cover.

Lubrication

The following describes all lubricating tasks which should be performed with the superstructure.

Greasing the swivel gear

- Fill grease through the grease nipple (1) with a grease gun.



Grease at each 90° position of the swivel gear. Fill a total of approx. 50 g of grease (approx. 20 shots with the grease gun). Refer to the "Recommended lubricants" section (page 157).



When moving the swivel frame, make sure no person or material is in the swivel area. Turn the starter switch to the STOP position and remove the key before the next greasing procedure.

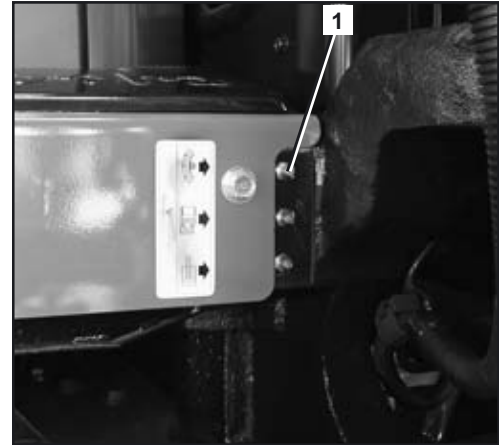

- Operate the excavator and swivel the swivel frame by 90° several times. After greasing, swivel the swivel frame 360° several times to distribute the grease evenly.

Greasing the pitch bearing

- Fill grease through the grease nipple (1) with a grease gun.



Grease at each 90° position of the pitch bearing. Using the grease gun, apply 5 shots at every position. Refer to the "Recommended lubricants" section (page 157).



When moving the swivel frame, make sure no person or material is in the swivel area. Turn the starter switch to the STOP position and remove the key before the next greasing procedure.

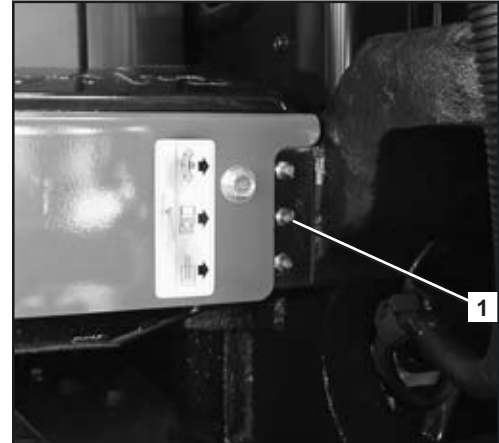

- Operate the excavator and swivel the swivel frame by 90° several times. After greasing, swivel the swivel frame 360° several times to distribute the grease evenly.

Greasing the swing bracket

- Lubricate both greasing points (see figure to the right) – see the "Recommended lubricants" section (page 157) – by injecting grease until fresh grease emerges.



Wipe emerged grease off immediately and store dirty cleaning cloths in the containers provided for disposal.

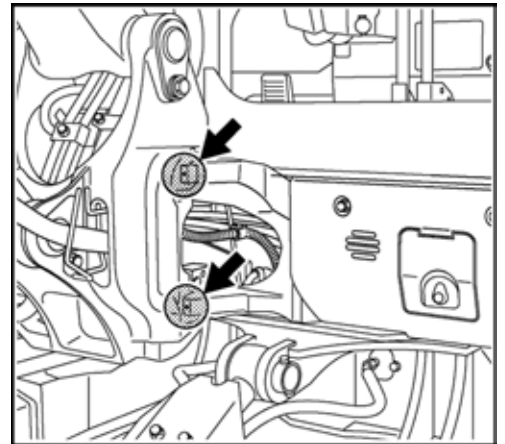

Other greasing points

- Start the engine (page 69).
- Position the boom, arm, and dozer as shown in the figure. Stop the engine, remove the key. Refer to the "Operating the controls during excavation work" section) (page 78).

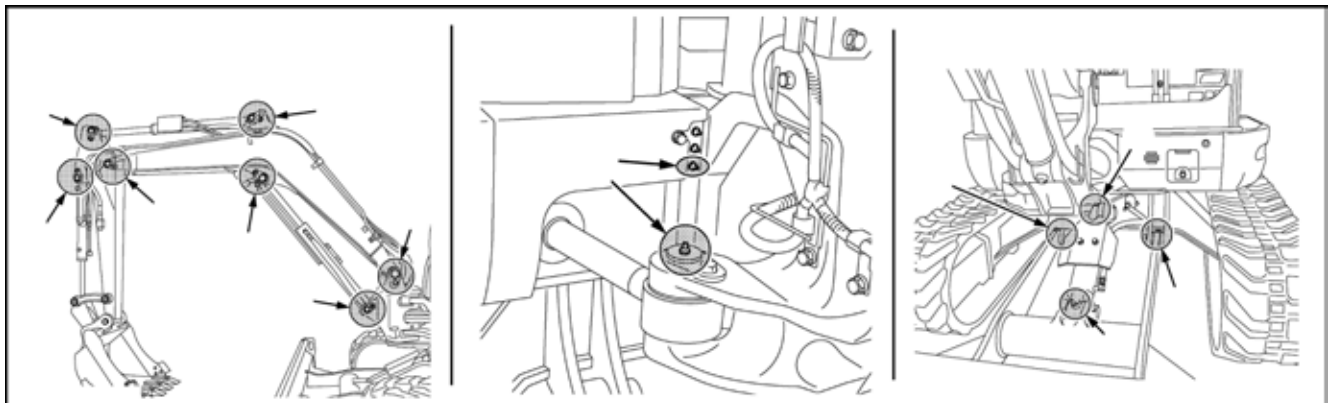

- Lubricate all greasing points with grease – see the "Recommended lubricants" section (page 157) – until fresh grease emerges.



Wipe emerged grease off immediately and store dirty cleaning cloths in the containers provided for disposal.

Checking and tensioning the crawler tension



If the crawlers are too tight, wear is increased.



If the crawlers are too loose, wear is increased and the crawlers may come off.

When parking an excavator with rubber crawlers, ensure that the seam (∞) is on top half way between the two sliders (see figure/1, "Checking the crawler tension", page 148).

- Clean all parts of the running gear, paying particular attention to stones between the crawler and sprocket or idler. Clean the area of the crawler tensioning cylinder.
- Swivel the swivel frame 90° to the direction of travel as shown in the figure.
- Lower the front attachments on the ground and raise the excavator about 200 mm off the ground on one side.

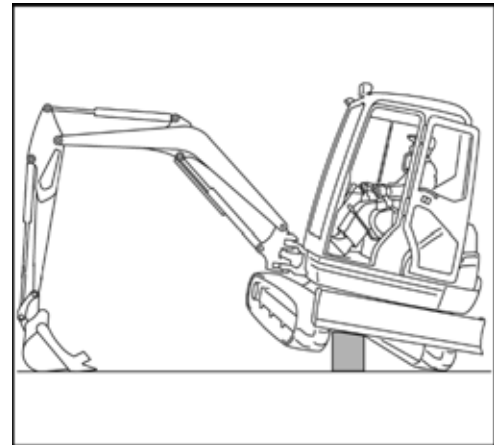

Have a guide supervise the procedure.



Support the excavator with appropriate backing material, observing the vehicle weight.

Checking the crawler tension

- The crawler seam (1) is half way between the idler and sprocket.
- Check the crawler sag as shown in the figure.

Crawler sag "A" 10-15 mm

- If the crawler sag is more than 15 mm, adjust the crawler.
- If necessary, tighten or loosen the crawler.
- Start the engine and rotate the lifted crawler briefly.

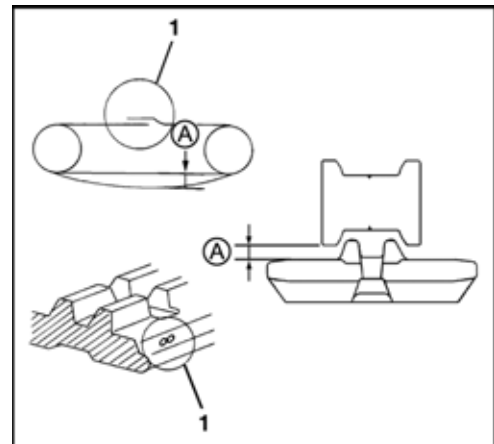

Caution: The area around the rotating crawler must be free of persons. Turn the starter switch to the STOP position after turning and remove the key.

- Recheck the crawler tension, readjusting it if necessary.
- Perform the procedures on the second crawler.

Maintenance

Checking the crawler tension (steel)

- Check the crawler sag as shown in the figure.

Crawler sag "A" 75-80 mm

- If the crawler sag is more than 80 mm, adjust the crawler.
- If necessary, tighten or loosen the crawler.
- Start the excavator and rotate the lifted crawler briefly.

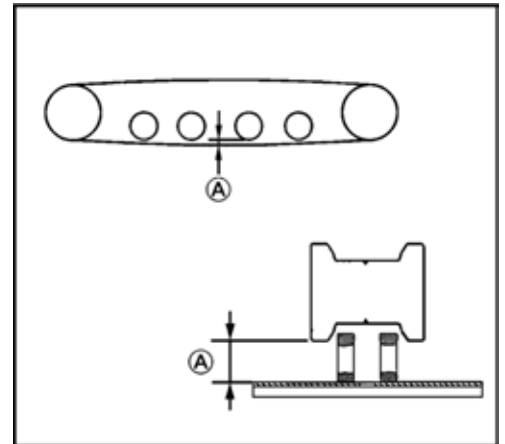

Caution: The area around the rotating crawler must be free of persons. Turn the starter switch to the STOP position after turning and remove the key.

- Recheck the crawler tension, readjusting it if necessary.
- Perform the procedures on the second crawler.

Adjusting the crawler tension

Tightening the crawlers

- Remove the crawler tensioner cover (3).
- Position the grease gun on the grease nipple (1).
- Pump the grease gun until the specified crawler tension is obtained.

Loosening the crawlers

- Cautiously unscrew the pressure valve (2) and loosen the crawler.

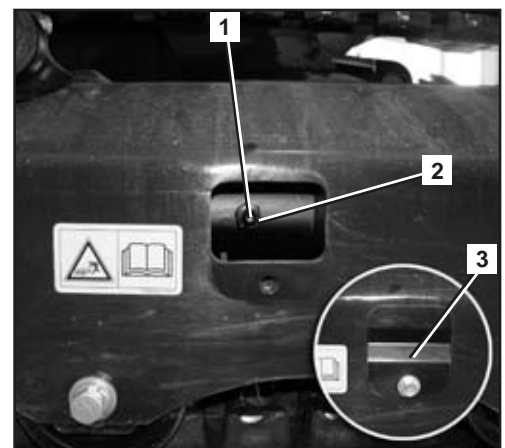

Grease could squirt out from the cylinder opening.

- Screw in the pressure valve and torque to 98-108 Nm.
- Tighten the crawler.

Replace the drive unit oil



Only change the oil when the drive unit is warm to the hand; if not, drive the excavator warm.

- Park the excavator on level ground so that the drain plug (figure below, position 3) is positioned at the bottom.
- Place a catch tray with a minimum capacity of 2 L under the drain plug.
- Remove the drain plug and let the oil drain completely. Install the drain plug with a new sealing ring on it.
- Remove the oil filler plug (2) and oil level screw (1).
- Fill oil as specified in the "Recommended lubricants" section (page 157). The oil level is the lower edge of the thread.

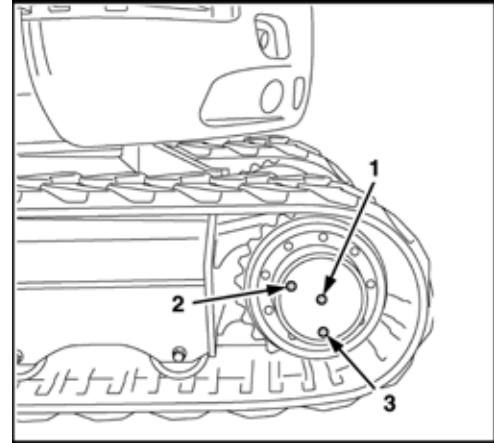

Capacities: 0.9 L

- Refit the oil filler plug and the set screw with a new sealing ring and tighten it.
- Perform the same service on the second drive unit.

Checking, cleaning, replacing the interior air filter



If the excavator is operated in a particularly dusty environment, the interior air filter must be checked more often.

- Remove the screw (1).
- Open the cover plate (2).
- Remove the interior air filter (3).

Checking

- Inspect the interior air filter for contamination and damage. In case of heavy contamination, replace the interior air filter.

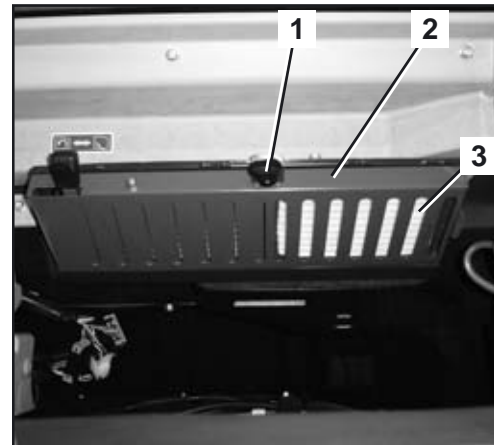

Maintenance

Cleaning



Clean only with filtered air at max. 2 bar pressure.



Always wear eye protection when working with compressed air.

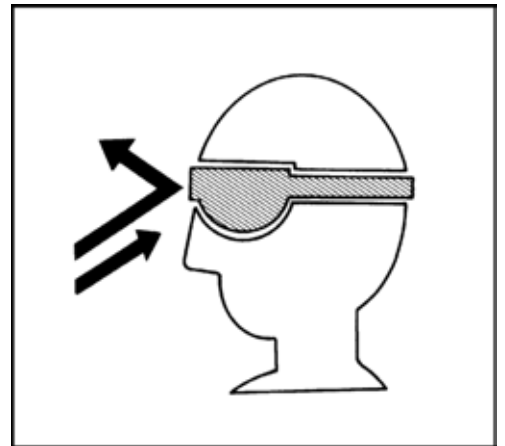

- Clean the filter (1) with compressed air in direction "A", opposite the normal direction of flow.



Take care not to damage the filter when installing it. A damaged filter would allow contaminated air to enter the air-conditioner assembly, causing severe damage.

- Replace the interior air filter.
- Close the cover.
- Tighten the screw.

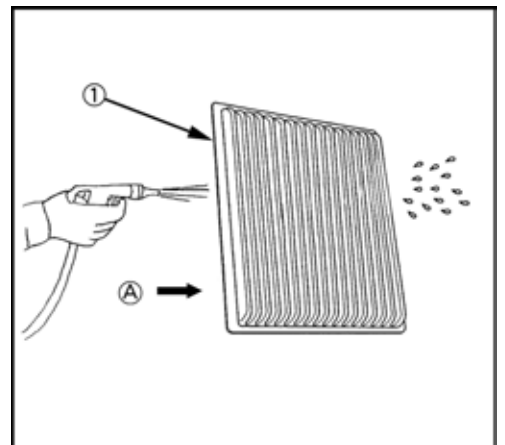

Checking the pipes and hoses of the heating and air-conditioner systems



Carry out the inspection while the engine is cold.

- Open the engine compartment cover (page 110).
- Open the side cover (page 111).
- Check that all the pipes and hoses of the heating and air-conditioner systems are in serviceable condition (no cracks, bulges or hard spots) and are firmly seated. If there are any defects found, consult your KUBOTA dealer. Only trained personnel may work on the heating and air-conditioner systems.
- Close the engine compartment and side cover.

Checking the coolant content (air-conditioner only)



Avoid eye and skin contact. The refrigerant causes severe frostbite.



When working with refrigerants, always wear an eye protection.



Avoid contact of refrigerant and open flames. Burning the refrigerant produces a toxic gas.



Do not detach or deactivate any components of the air-conditioner. Please contact your KUBOTA dealer.

A low refrigerant level affects the performance of the equipment and the air-conditioner will eventually automatically switch off. If you find out that the refrigerant level is too low, please contact your KUBOTA dealer.

- Open the side cover (page 111).
- Start the engine (page 69) and set an idle speed of 1500 rpm, if necessary.
- Set the temperature control to the "Cold" position and the fan to level 3, then switch on the air-conditioner.
- Using the sight glass (1), determine the refrigerant level according to the table below. If the refrigerant level is too low, please contact your KUBOTA dealer.

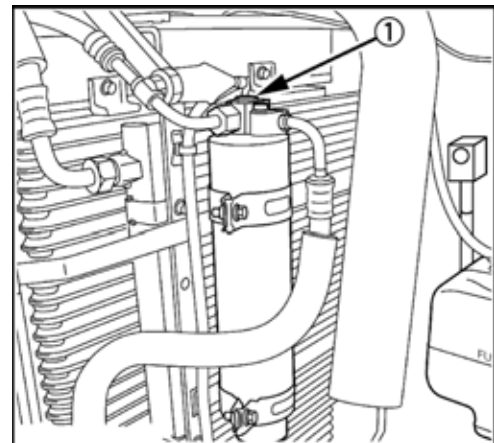

	Refrigerant level is OK	Small or no bubbles in the refrigerant
	Refrigerant level too low	Many large bubbles and foam in the refrigerant
	No refrigerant inside	Colourless and transparent

- Close the side cover.

Viewing the operations log

The operations log enables the operation of the excavator over the previous three months to be checked.

- Turn the starter switch to the RUN position.
- Press button 1.

The user menu appears in the display.

- Press button 2 or 3 until "Log Record" is selected in the display.
- Press button 5 to confirm.

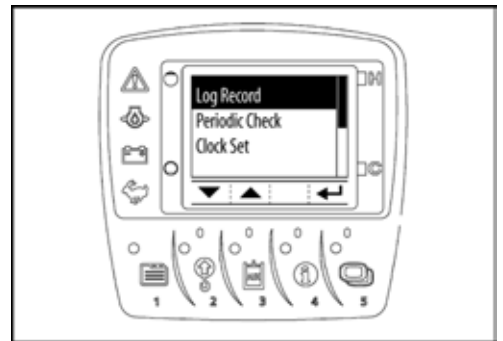

A calendar appears in the display. The days on which the excavator was operated are highlighted.

- Press button 2 to display operation of the excavator over the past three months.



Certain days may be marked with (-) if the clock was reset or the battery disconnected. Operation of the excavator on these days cannot be traced.

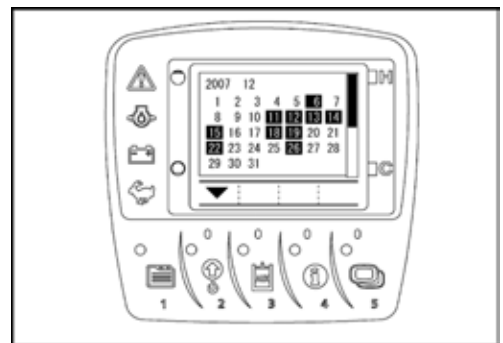

Checking the bolted joints

The table below contains the torques for nuts and bolts. These may only be tightened with a torque wrench. Missing torques can be requested from KUBOTA.

Tightening torque for screws

Nm (kgf•m)

	4 T (4.6)	7 T (8.8)	9 T (9.8-10.9)
M 6	7.8~9.3 (0.8~0.95)	9.8~11.3 (1.0~1.15)	12.3~14.2 (1.25~1.45)
M 8	17.7~20.6 (1.8~2.1)	23.5~27.5 (2.4~2.8)	29.4~34.3 (3.0~3.5)
M 10	39.2~45.1 (4.0~4.6)	48.1~55.9 (4.9~5.7)	60.8~70.6 (6.2~7.2)
M 12	62.8~72.6 (6.4~7.4)	77.5~90.2 (7.9~9.2)	103.0~117.7 (10.5~12.0)
M 14	107.9~125.5 (11.0~12.8)	123.6~147.1 (12.6~15.0)	166.7~196.1 (17.0~20.0)
M 16	166.7~191.2 (17.0~19.5)	196.1~225.6 (20.0~23.0)	259.9~304.0 (26.5~31.0)
M 20	333.4~392.3 (34.0~40.0)	367.7~431.5 (37.5~44.0)	519.8~568.8 (53.0~58.0)

Tightening torque for hose clamps

Diameter	Part name	Tightening torque
Ø 10~14	Clamp (screw version 14)	2.5~3.4 Nm
Ø 12~16	Clamp (screw version)	2.5~3.4 Nm
Ø 13~20	Clamps (13-20)	2.5~3.4 Nm
Ø 19~25	Clamp (screw version)	2.5~3.4 Nm
Ø 31~40	Clamp (screw version)	2.5~3.4 Nm
Ø 36~46	Clamp (screw version)	2.5~3.4 Nm
Ø 15~25	Clamps (15-24)	4.9~5.9 Nm
Ø 26~38	Clamps (26-38)	4.9~5.9 Nm
Ø 32~44	Clamps (32-44)	4.9~5.9 Nm
Ø 40~55	Clamps (40-55)	4.9~5.9 Nm
Ø 44~53	Clamp (screw version)	4.9~5.9 Nm
Ø 49~60	Clamp (screw version 60)	4.9~5.9 Nm
Ø 50~60	Clamps (50-60)	4.9~5.9 Nm
Ø 58~75	Clamps (58-75)	4.9~5.9 Nm
Ø 66~88	Clamps (66-88)	4.9~5.9 Nm
Ø 77~95	Clamps (77-95)	4.9~5.9 Nm

Tightening torque for hydraulic hoses

Nm (kgf•m)

Dimension (ORS)	Nut type (Metal seal)	Nut type (ORS)
1/8 (-)	7.8~11.8 (0.8~1.2)	--
1/4 (9/16-18)	24.5~29.4 (2.5~3.0)	35.2~43.1 (3.6~4.4)
3/8 (11/16-16)	37.2~42.1 (3.8~4.3)	60.0~73.5 (6.1~7.5)
1/2 (13/16-16)	58.8~63.7 (6.0~6.5)	70.6~86.2 (7.2~8.8)
3/4 (1-14)	117.6~127.4 (12.0~13.0)	105.8~129.4 (10.8~13.2)
1 1/4 (-)	220.5~230.3 (22.5~23.5)	--

Tightening torque for hydraulic pipes

Size of the steel pipe (OD × ID × thickness)	Tightening torque Nm kgf•m	Wrench size (guide number)	Comments
8 × 6 × 1 mm 0.31 × 0.24 × 0.04 in.	29.4~39.2 3.0~4.0	17 mm 0.67 in.	When using a union nut
10 × 7 × 1.5 mm 0.39 × 0.28 × 0.06 in.	39.2~44.1 4.0~4.5	19 mm 0.75 in.	
12 × 9 × 1.5 mm 0.47 × 0.35 × 0.06 in.	53.9~63.7 5.5~6.5	21 mm 0.83 in.	
16 × 12 × 2 mm 0.63 × 0.47 × 0.08 in.	88.3~98.1 9.0~10.0	29 mm 1.14 in.	
18 × 14 × 2 mm 0.71 × 0.55 × 0.08 in.	127.5~137.3 13.0~14.0	32 mm 1.26 in.	
27.2 × 21.6 × 2.8 mm 1.07 × 0.85 × 0.11 in.	235.4~254.97 24.0~26.0	41 mm 1.61 in.	

Tightening torque for hydraulic adapters

Thread size (Pipe union)	Tightening torque		Wrench size (guide number)	Comments Steel pipe (OD)	
	Nm kgf•m				
	R (conical thread)	G (round thread)			
1/8"	19.6~29.4 2.0~3.0	--	17 mm 0.67 in.	When using a steel pipe.	8 mm 0.31 in.
1/4"	36.3~44.1 3.7~4.5	With O-ring Tightening torque for connections 58.8~78.5 6~8	19 mm 0.75 in.		12 mm 0.47 in.
3/8"	68.6~73.5 7.0~7.5	With O-ring Tightening torque for connections 78.5~98.1 8~10	23 mm 0.91 in.		15 mm 0.59 in.
1/2"	83.4~88.3 8.5~9.0	With O-ring Tightening torque for connections 117.7~137.3 12~14	26 mm 1.02 in.		16 mm 0.63 in.
3/4"	166.6~181.3 17.0~18.5				

Tightening torque for elbow pipe joints with shim

Size	Nm	kgf•m
G1/8	15.0~16.5	1.5~1.7
G1/4	24.5~29.4	2.5~3.0
G3/8	49.0~53.9	5.0~5.5
G1/2	58.8~63.7	6.0~6.5
G3/4, G1	117.6~127.4	12.0~13.0
G1,1/4	220.5~230.3	22.5~23.5
7/8-14UNF	55.9~60.8	5.7~6.2

Recommended lubricants



- The excavator is shipped with Shell Tellus S2M46 hydraulic oil.
- If bio oil is used, please contact your KUBOTA dealer.
- Use only API CF or API CI-4 grade engine oil. Do not use different grades, such as CF-4, CG-4 or CH-4.
- For the drive units use gear oil SAE 90 (API, CLA/GL5) in all seasons.
- The use of diesel fuel with a sulphur content of less than 0.10% (1000 ppm) is strongly recommended.
- When diesel fuel with a high sulphur content [between 0.50 % (5000 ppm) and 1.0 % (10000 ppm)] is used, the engine oil and engine oil filter must be replaced at shorter intervals (roughly half as long).
- Never use diesel fuel with a sulphur content exceeding 1.0 % (10000 ppm).
- Diesel fuels complying with the current EN 590 or ASTM D975 are recommended.

EN: European standard

ASTM: American Society for Testing and Materials

	Range of use	Viscosity	Shell	Mobil	Exxon	MIL-Standard
1*	In winter or at low temperatures	SAE 10W	Shell Rotella T10W	Mobil Delvac 1310	XD-3 10W	MIL-L-2104C MIL-L-2104D
			Shell Rimula 10W		XD-3 Extra 10W	
		SAE 20W	Shell Rotella T20W-2	Mobil Delvac 1320	XD-3 20W-20	
			Shell Rimula 20W-2		XD-3 Extra 20W-20	
	In summer or at high ambient temperatures	SAE 30	Shell Rotella T30	Mobil Delvac 1330	XD-3 30	
			Shell Rimula 30		XD-3 Extra 30	
SAE 40		Shell Rotella T40	Mobil Delvac 1340	XD-3 40		
	SAE 50	Shell Rimula 40		XD-3 Extra 40		
	SAE 50	Shell Rimula 50	Mobil Delvac 1350			
	All-weather engine oil	Multi-grade oil	Shell Rotella T15W		XD-3 15W-40 XD-3 Extra 15W-40	
2*	In winter or at low temperatures	SAE 75	Shell Oil S 8643	Mobilube HD80W-90		MIL-L-2105C
		SAE 80	Shell Spirax HD80W	Mobilube HD80W-90		
	In summer or at high ambient temperatures	SAE 90	Shell Spirax HD90	Mobilube 46		MIL-L-2105
			Mobilube HD80W-90		MIL-L-2105C	
		SAE 140	Shell Spirax HD140	Mobilube HD85W-140 Mobilube HD80W-140		MIL-L-2105C
	All-weather gear oil	Multi-grade oil	Shell Spirax HD80W Shell Spirax HD85W	Mobilube HD80W-90	GX80W-90	MIL-L-2105C
3*	In winter or at low temperatures	ISO 32	Shell Tellus S2M32	Mobil DTE-Oil 13	NUTO H32	
		ISO 46	Shell Tellus S2M46	Mobil DTE-Oil 15	NUTO H46	
	In summer or at high ambient temperatures	ISO 68	Shell Tellus S2M68	Mobil DTE-Oil 16	NUTO H68	
Grease			Shell Alvania EP2	Mobilux EP2	BEACON Q2	
Fuel		Summer diesel (ASTM D975/EN 590)				
Fuel below -5 °C		Diesel fuel for cold weather operation				
Antifreeze for the cooling system		G048	Antifreeze, free from nitrate, phosphate and amine according to the MB specification 325.0			
Special grease for use during the first 50 hours of operation		NLGI-1	WEICON ANTI-SEIZE			

1* Engine oil

2* Gear oil

3* Hydraulic oil

Excavator repairs

Repairs on the excavator may only be carried out by trained personnel.

If repairs are carried out on supporting parts, for example welding on frame parts, the work must be checked by an expert.

After repairs the excavator may only be taken into operation if its proper operation has been determined. For this check particular attention must be paid to the repaired parts and the safety devices.

Safety inspection

All safety inspections are based on the national worker's protection regulations, safety regulations and technical specifications applicable to the country where the machine is deployed.

The owner (operator) (page 18) should arrange for the safety inspections to be performed at specified intervals according to national rules and regulations.

Due to his training and experience, the skilled person must have sufficient knowledge of excavators and be familiar with the applicable national worker's protection regulations, safety regulations and the generally accepted technical rules so that they can assess the safe condition of the excavator.

The expert must keep his appraisal and evaluation neutral and must not be influenced by personal, economic or company interests. The inspection is a visual and functional check of all components for condition and completeness and of the effectiveness of the safety devices.

The performance of the inspection must be documented as an inspection report containing at least the following information:

- Date and scope of the inspection indicating all pending checks,
- Result of the inspection with a report of the determined faults,
- Assessment in respect to starting or continuing operation,
- Information on necessary follow-up inspections and
- Name, address and signature of the inspector.

The owner/employer (company) is responsible for the observance of the inspection intervals. The acknowledgement and the elimination of the determined faults must be confirmed by the owner/employer in writing, along with the date, in the inspection report.

The inspection report must be kept on file at least until the next inspection.

Taking out of service and storage

If the excavator is taken out of service for up to six months, the measures before, during and after taking out of service must be carried out as described below. If the vehicle is to be taken out of service for a period of over six months, contact the manufacturer for additional measures.

Safety rules for taking out of service and storage

The general safety rules (page 14), the safety rules for operation (page 57) and the safety rules for maintenance (page 124) apply.

When taking the excavator out of service, secure it against unauthorised use.

Storage conditions

The storage place must have a sufficient bearing capacity for the weight of the excavator.

The storage place must be frost-free, dry and well ventilated.

Measures before taking out of service

- Clean and dry the excavator thoroughly (page 129).
- Check the hydraulic oil level, add hydraulic oil if necessary (page 142).
- Change the engine oil and oil filter (page 133).
- Drive the excavator to the storage place.
- Remove the battery (page 145) and store it in a dry and frost-free room. If necessary, connect it to a trickle charger.
- Grease the swivel gear (page 146).
- Grease the pitch bearing (page 146).
- Grease all other greasing points (page 147).
- Grease the swing bracket (page 147).
- Grease the bucket bolt and bucket linkage bolt (page 65).
- Check the antifreeze content of the coolant, add coolant if necessary (page 129).
- Grease the hydraulic cylinder piston rods.

Measures during taking out of service

- Charge the battery regularly (page 144).

Start-up after taking out of service

- If necessary, clean the excavator thoroughly (page 129).
- Check the hydraulic oil for condensate water. Replace the oil if necessary (page 142).
- Remove the grease from the piston rods of the hydraulic cylinders.
- Install the battery (page 145).
- Check the safety devices for proper operation.
- Carry out the pre-operational services (page 62). If defects are detected during start-up, repair the defects before proceeding.
- If the safety inspection is due while the vehicle has been taken out of service, the inspection must be performed before start-up.
- Start the engine (page 69). Run the excavator at idle and check all functions.

Lifting capacity of the excavator

Constructive calculation of lifting capacity

- The lifting capacity of the excavator is based on ISO 10567 and does not exceed 75 % of the static tipping load or 87 % of the hydraulic lifting capacity of the machine.
- The lifting capacity is measured at the front pin part of the arm with the arm fully extended. The arm is fully in the dump position. The boom cylinder is the operating cylinder.

- The lifting conditions are:

1. Swivel up to 360°

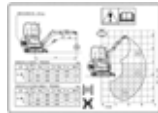

2. Over front end, dozer down



- As well as the lifting conditions, the length of the arm also affects the permitted lifting capacities and the stability of the machine. Compare the dimensions of the machine arm with the details given in the lifting capacity tables, in order to use the correct lifting capacity table for your machine.



Dimensions for the arm, see table "Design of arm" in the section "Dimensions" (page 37).

Lifting attachment

- The machine may not be deployed for lifting operation unless there is a pipe safety valve installed on the boom cylinder and on the arm cylinder according to EN 474-5. An additional pipe safety valve in accordance with EN 474-1 must be installed before using the dozer for lifting operation support.
- When the overload warning function is enabled, the machine may be used for lifting operation only. For more information, see chapter Safety rules, section Overload warning function (page 28).
- The lifting attachment is to be attached to the implement or to other parts of the excavator in such a manner as to exclude the possibility of the lifting rope accidentally unhooking.
- Attachment to the implement or the equipment must be such as to guarantee the optimum field of vision between the operator and the guide [the person who fastens the lifting rope to the lifting attachment].
- The lifting attachment is to be positioned so that the lifting rope is not deflected from its vertical direction of tension by other parts of the machine.
- The lifting attachment must be formed and positioned in such a manner as to exclude the possibility of the lifting rope accidentally slipping.
- Care must be taken when positioning the lifting attachment that there is no risk of restriction (e.g. becoming caught on something) during normal operation of the excavator or when working on any particular object.
- Load suspensions (e.g. hooks) may only be welded on by suitably qualified personnel. For this type of work, please contact your KUBOTA dealer.
- At every point of the implement or the boom, the lifting attachment must withstand a load of two-and-a-half-times its rated lifting load.

Lifting capacity of the excavator

Load suspension device

Assumed is a load suspension device with all the characteristics listed below.

- The system must withstand a load two-and-a-half-times its rated lifting load, irrespective of the point at which that load is applied.
- The system must be designed in such a way as to practically exclude any objects which have been lifted falling from the lifting attachment, for example by means of a protective attachment designed for this purpose.
- The system must not allow the lifting attachment to slip from the implement to be lifted.



Do not lift loads which exceed the values indicated in the lifting capacity tables.



Always observe the maximum permissible lifting capacity of the hoisting gear (e.g. load hooks). The lifting of loads over the maximum permissible lifting capacity is not allowed.



The values given in the tables apply only to level and hard grounds. When working on soft ground, the machine can tip over easily, as the load is concentrated on one side only and the track or the dozer can dig into the ground.



The values given in the tables apply only for loads without bucket. If a bucket is used, the weight of the bucket must be subtracted from the values in the tables. The weight of mounted accessories (e.g. clamp kit, quick release coupling, etc.) must be subtracted from the lifting capacity.



It is not allowed to swing the boom during lifting operation. The whole machine could tilt!

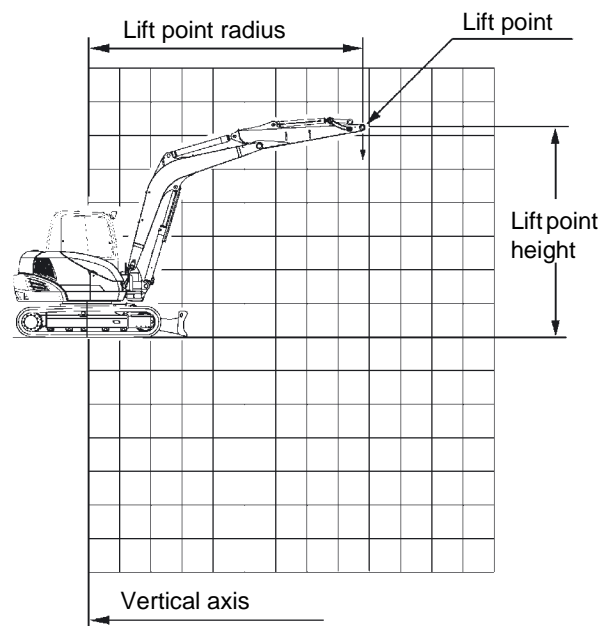
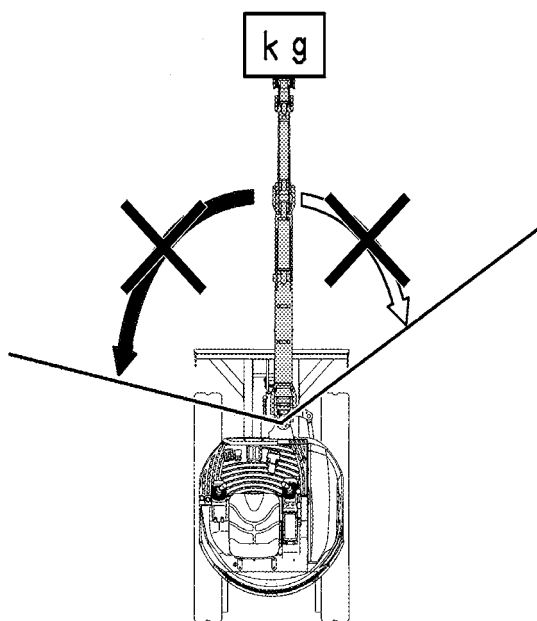

Max. lifting load during swivel operation is 360°

KX057-4 / arm 1570 mm and arm 1820 mm

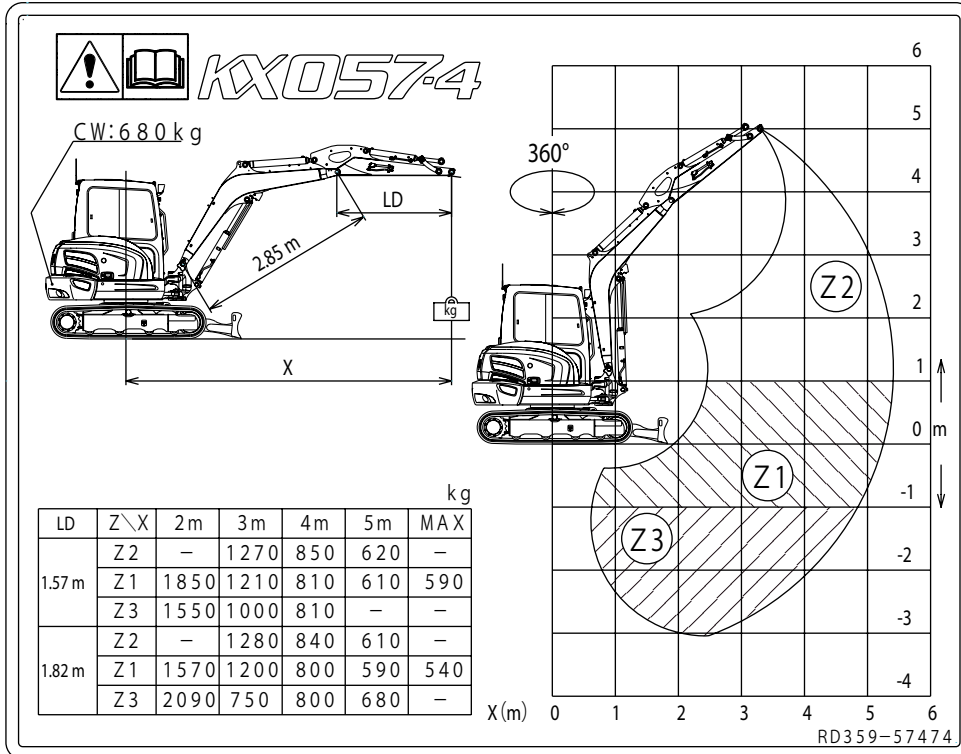

U48-4 / arm 1450 mm

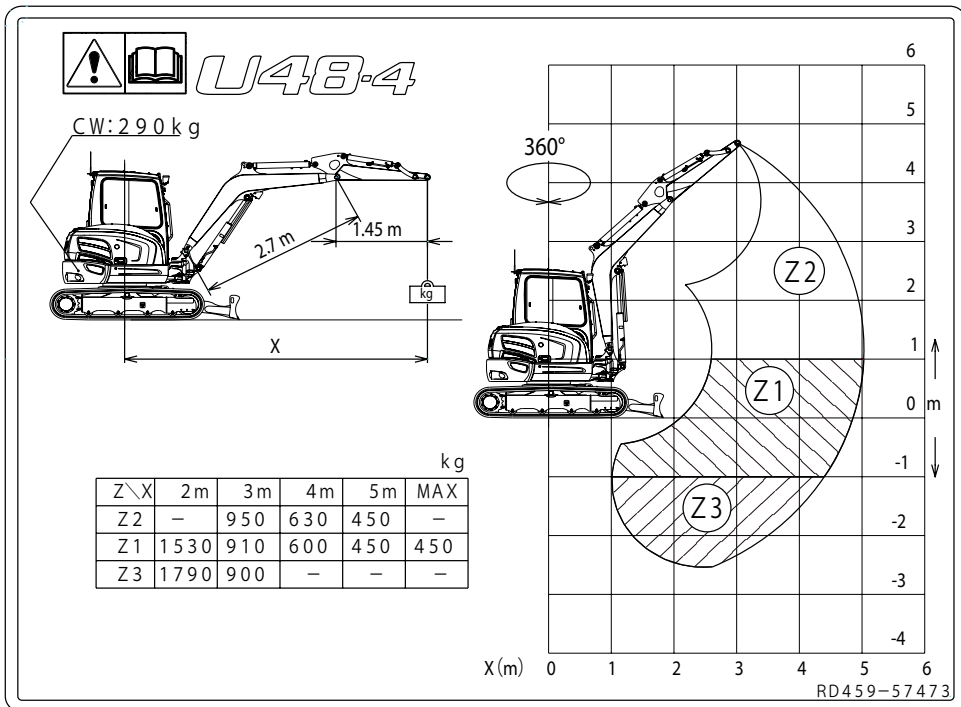

Lifting capacity of the excavator

U55-4 / arm 1570 mm

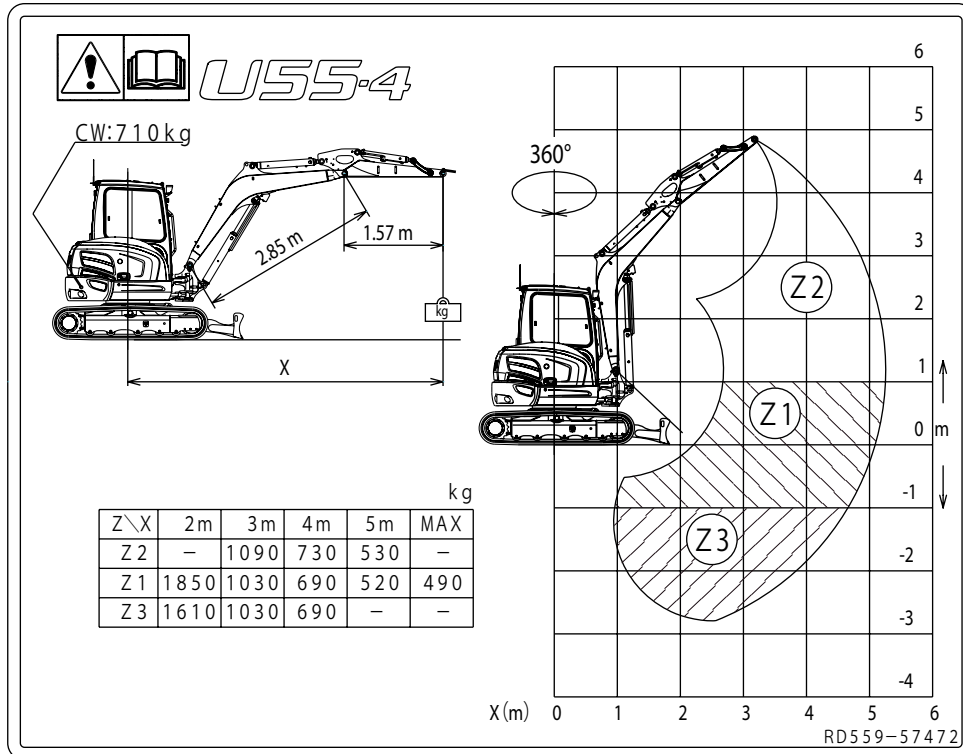

Lifting capacity over front end, dozer down

MODEL	KX057-4	SPECIFICATION	CAB VERSION WITH RUBBER CRAWLER
	KBM		ARM 1820 mm

kN (t)

LIFT POINT HEIGHT [mm]	LIFT POINT RADIUS (mm)												
	Minimum	1000	1500	2000	2500	3000	3500	4000	4500	5000	Maximum		
GL	4000								9.9 (1.01)				
	3500								9.9 (1.01)	10.0 (1.02)			
	3000							10.5 (1.07)	10.3 (1.05)	10.2 (1.04)	9.5 (0.97)	8.7 (0.89)	
	2500								11.8 (1.20)	11.1 (1.13)	10.6 (1.08)	10.2 (1.05)	8.7 (0.88)
	2000						19.0 (1.93)	15.4 (1.57)	13.4 (1.36)	12.0 (1.23)	11.2 (1.14)	10.5 (1.07)	8.7 (0.89)
	1500					24.3 (2.48)	18.3 (1.86)	15.1 (1.54)	13.1 (1.34)	11.8 (1.21)	10.9 (1.11)	8.9 (0.91)	
	1000					28.4 (2.89)	20.7 (2.12)	16.6 (1.70)	14.1 (1.44)	12.4 (1.27)	11.2 (1.15)	9.3 (0.95)	
	500					25.2 (2.57)	22.3 (2.28)	17.8 (1.81)	14.9 (1.52)	12.9 (1.32)	11.5 (1.17)	9.8 (1.00)	
	0				15.4 (1.57)	27.3 (2.79)	23.0 (2.35)	18.4 (1.88)	15.3 (1.57)	13.2 (1.34)	11.5 (1.17)	10.5 (1.07)	
	-500	11.3 (1.15)	15.7 (1.60)	16.4 (1.67)	21.2 (2.16)	29.5 (3.01)	22.9 (2.33)	18.4 (1.88)	15.4 (1.57)	13.1 (1.33)	11.1 (1.13)	10.7 (1.10)	
	-1000	16.9 (1.72)	20.4 (2.09)	22.3 (2.27)	27.7 (2.83)	27.8 (2.84)	21.9 (2.24)	17.8 (1.82)	14.9 (1.52)	12.5 (1.27)			
	-1500	18.9 (1.92)	25.8 (2.63)	28.8 (2.94)	33.2 (3.39)	25.3 (2.58)	20.2 (2.06)	16.5 (1.69)	13.7 (1.39)	10.9 (1.11)			
	-2000	20.4 (2.08)	32.0 (3.26)	36.6 (3.73)	27.9 (2.84)	21.7 (2.21)	17.5 (1.79)	14.2 (1.45)	11.2 (1.14)				
	-2500			27.8 (2.83)	20.5 (2.09)	16.4 (1.67)	13.1 (1.34)						

Lifting capacity over front end, dozer down

MODEL	KX057-4	SPECIFICATION	CAB VERSION WITH STEEL CRAWLER
	KBM		ARM 1820 mm

kN (t)

LIFT POINT HEIGHT [mm]	LIFT POINT RADIUS (mm)												
	Minimum	1000	1500	2000	2500	3000	3500	4000	4500	5000	Maximum		
GL	4000								9.9 (1.01)				
	3500								9.9 (1.01)	10.0 (1.02)			
	3000							10.5 (1.07)	10.3 (1.05)	10.2 (1.04)	9.5 (0.97)	8.7 (0.89)	
	2500								11.8 (1.20)	11.1 (1.13)	10.6 (1.08)	10.2 (1.05)	8.7 (0.88)
	2000						19.0 (1.93)	15.4 (1.57)	13.4 (1.36)	12.0 (1.23)	11.2 (1.14)	10.5 (1.07)	8.7 (0.89)
	1500					24.3 (2.48)	18.3 (1.86)	15.1 (1.54)	13.1 (1.34)	11.8 (1.21)	10.9 (1.11)	8.9 (0.91)	
	1000					28.4 (2.89)	20.7 (2.12)	16.6 (1.70)	14.1 (1.44)	12.4 (1.27)	11.2 (1.15)	9.3 (0.95)	
	500					25.2 (2.57)	22.3 (2.28)	17.8 (1.81)	14.9 (1.52)	12.9 (1.32)	11.5 (1.17)	9.8 (1.00)	
	0				15.4 (1.57)	27.3 (2.79)	23.0 (2.35)	18.4 (1.88)	15.3 (1.57)	13.2 (1.34)	11.5 (1.17)	10.5 (1.07)	
	-500	11.3 (1.15)	15.7 (1.60)	16.4 (1.67)	21.2 (2.16)	29.5 (3.01)	22.9 (2.33)	18.4 (1.88)	15.4 (1.57)	13.1 (1.33)	11.1 (1.13)	10.7 (1.10)	
	-1000	16.9 (1.72)	20.4 (2.09)	22.3 (2.27)	27.7 (2.83)	27.8 (2.84)	21.9 (2.24)	17.8 (1.82)	14.9 (1.52)	12.5 (1.27)			
	-1500	18.9 (1.92)	25.8 (2.63)	28.8 (2.94)	33.2 (3.39)	25.3 (2.58)	20.2 (2.06)	16.5 (1.69)	13.7 (1.39)	10.9 (1.11)			
	-2000	20.4 (2.08)	32.0 (3.26)	36.6 (3.73)	27.9 (2.84)	21.7 (2.21)	17.5 (1.79)	14.2 (1.45)	11.2 (1.14)				
	-2500			27.8 (2.83)	20.5 (2.09)	16.4 (1.67)	13.1 (1.34)						

Lifting capacity of the excavator

Lifting capacity over front end, dozer down

MODEL	KX057-4	SPECIFICATION	CAB VERSION WITH WIDE STEEL CRAWLER
	KBM		ARM 1820 mm

LIFT POINT HEIGHT [mm]		LIFT POINT RADIUS (mm)											kN (t)	
		Minimum	1000	1500	2000	2500	3000	3500	4000	4500	5000	Maximum		
GL	4000									9.9 (1.01)				
	3500									9.9 (1.01)	10.0 (1.02)			
	3000								10.5 (1.07)	10.3 (1.05)	10.4 (1.04)	9.5 (0.97)	8.7 (0.89)	
	2500									11.8 (1.20)	11.1 (1.13)	10.6 (1.08)	10.2 (1.05)	8.7 (0.88)
	2000						19.0 (1.93)	15.4 (1.57)	13.4 (1.36)	12.0 (1.23)	11.2 (1.14)	10.5 (1.07)	10.5 (1.07)	8.7 (0.89)
	1500					24.3 (2.48)	18.3 (1.86)	15.1 (1.54)	13.1 (1.34)	11.8 (1.21)	11.8 (1.21)	10.9 (1.11)	8.9 (0.91)	
	1000					28.4 (2.89)	20.7 (2.12)	16.6 (1.70)	14.1 (1.44)	12.4 (1.27)	12.4 (1.27)	11.2 (1.15)	9.3 (0.95)	
	500					25.2 (2.57)	22.3 (2.28)	17.8 (1.81)	14.9 (1.52)	12.9 (1.32)	12.9 (1.32)	11.5 (1.17)	9.8 (1.00)	
	0					15.4 (1.57)	27.3 (2.79)	23.0 (2.35)	18.4 (1.88)	15.3 (1.57)	13.2 (1.34)	11.5 (1.17)	10.5 (1.07)	
	-500		11.3 (1.15)	15.7 (1.60)	16.4 (1.67)	21.2 (2.16)	29.5 (3.01)	22.9 (2.33)	18.4 (1.88)	15.4 (1.57)	13.1 (1.33)	11.1 (1.13)	10.7 (1.10)	
	-1000		16.9 (1.72)	20.4 (2.09)	22.3 (2.27)	27.7 (2.83)	27.8 (2.84)	21.9 (2.24)	17.8 (1.82)	14.9 (1.52)	12.5 (1.27)			
	-1500		18.9 (1.92)	25.8 (2.63)	28.8 (2.94)	33.2 (3.39)	25.3 (2.58)	20.2 (2.06)	16.5 (1.69)	13.7 (1.39)	10.9 (1.11)			
	-2000		20.4 (2.08)	32.0 (3.26)	36.6 (3.73)	27.9 (2.84)	21.7 (2.21)	17.5 (1.79)	14.2 (1.45)	11.2 (1.14)				
	-2500				27.8 (2.83)	20.5 (2.09)	16.4 (1.67)	13.1 (1.34)						

Lifting capacity over front end, dozer down

MODEL	KX057-4	SPECIFICATION	CAB VERSION WITH RUBBER CRAWLER
	KBM		ARM 1570 mm

LIFT POINT HEIGHT [mm]		LIFT POINT RADIUS (mm)											kN (t)
		Minimum	1000	1500	2000	2500	3000	3500	4000	4500	5000	Maximum	
GL	4500									11.8 (1.20)			
	4000									11.0 (1.12)	11.3 (1.15)		
	3500									11.1 (1.13)	11.0 (1.12)		
	3000								11.8 (1.20)	11.3 (1.16)	11.1 (1.13)		
	2500								14.5 (1.47)	13.0 (1.33)	12.0 (1.23)	11.4 (1.16)	
	2000						21.9 (2.23)	17.1 (1.74)	14.5 (1.48)	12.9 (1.32)	11.9 (1.21)	11.2 (1.14)	10.5 (1.07)
	1500							19.8 (2.02)	16.1 (1.64)	13.9 (1.42)	12.4 (1.27)	11.4 (1.16)	10.8 (1.10)
	1000							21.8 (2.23)	17.4 (1.78)	14.7 (1.50)	13.0 (1.32)	11.6 (1.19)	11.2 (1.14)
	500						22.0 (2.25)	23.0 (2.34)	18.3 (1.87)	15.3 (1.57)	13.3 (1.36)	11.7 (1.19)	11.3 (1.16)
	0						26.9 (2.74)	23.2 (2.36)	18.6 (1.90)	15.6 (1.59)	13.3 (1.36)	11.4 (1.17)	11.4 (1.16)
	-500				18.1 (1.85)	22.7 (2.31)	28.6 (2.91)	22.6 (2.30)	18.4 (1.88)	15.3 (1.57)	13.0 (1.32)		
	-1000		14.2 (1.45)	23.9 (2.44)	25.3 (2.58)	31.0 (3.16)	26.4 (2.70)	21.3 (2.17)	17.5 (1.78)	14.5 (1.48)	11.9 (1.21)		
	-1500		17.5 (1.78)	30.2 (3.08)	33.3 (3.40)	29.7 (3.03)	23.5 (2.39)	19.1 (1.95)	15.7 (1.60)	12.8 (1.30)			
	-2000				31.8 (3.25)	23.8 (2.43)	19.2 (1.96)	15.7 (1.51)	12.6 (1.28)				
-2500					15.2 (1.55)	12.7 (1.30)	9.8 (1.00)						

Lifting capacity over front end, dozer down

MODEL	KX057-4	SPECIFICATION	CAB VERSION WITH STEEL CRAWLER
	KBM		ARM 1570 mm

kN (t)

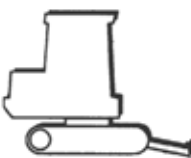
LIFT POINT HEIGHT [mm]	LIFT POINT RADIUS (mm)											
	Minimum	1000	1500	2000	2500	3000	3500	4000	4500	5000	Maximum	
GL	4500							11.8 (1.20)				
	4000							11.0 (1.12)	11.3 (1.15)			
	3500							11.1 (1.13)	11.0 (1.12)			
	3000						11.8 (1.20)	11.3 (1.16)	11.1 (1.13)			
	2500						14.5 (1.47)	13.0 (1.33)	12.0 (1.23)	11.4 (1.16)		
	2000					21.9 (2.23)	17.1 (1.74)	14.5 (1.48)	12.9 (1.32)	11.9 (1.21)	11.2 (1.14)	10.5 (1.07)
	1500						19.8 (2.02)	16.1 (1.64)	13.9 (1.42)	12.4 (1.27)	11.4 (1.16)	10.8 (1.10)
	1000					21.8 (2.23)	17.4 (1.78)	14.7 (1.50)	13.0 (1.32)	11.6 (1.19)	11.2 (1.14)	
	500					22.0 (2.25)	23.0 (2.34)	18.3 (1.87)	15.3 (1.57)	13.3 (1.36)	11.7 (1.19)	11.3 (1.16)
	0					26.9 (2.74)	23.2 (2.36)	18.6 (1.90)	15.6 (1.59)	13.3 (1.36)	11.4 (1.17)	11.4 (1.16)
	-500			18.1 (1.85)	22.7 (2.31)	28.6 (2.91)	22.6 (2.30)	18.4 (1.88)	15.3 (1.57)	13.0 (1.32)		
	-1000	14.2 (1.45)	23.9 (2.44)	25.3 (2.58)	31.0 (3.16)	26.4 (2.70)	21.3 (2.17)	17.5 (1.78)	14.5 (1.48)	11.9 (1.21)		
	-1500	17.5 (1.78)	30.2 (3.08)	33.3 (3.40)	29.7 (3.03)	23.5 (2.39)	19.1 (1.95)	15.7 (1.60)	12.8 (1.30)			
	-2000			31.8 (3.25)	23.8 (2.43)	19.2 (1.96)	15.7 (1.61)	12.6 (1.28)				
	-2500				15.2 (1.55)	12.7 (1.30)	9.8 (1.00)					

Lifting capacity over front end, dozer down

MODEL	KX057-4	SPECIFICATION	CAB VERSION WITH WIDE STEEL CRAWLER
	KBM		ARM 1570 mm

kN (t)

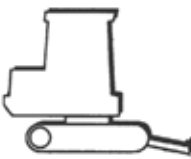
LIFT POINT HEIGHT [mm]	LIFT POINT RADIUS (mm)											
	Minimum	1000	1500	2000	2500	3000	3500	4000	4500	5000	Maximum	
GL	4500							11.8 (1.20)				
	4000							11.0 (1.12)	11.3 (1.15)			
	3500							11.1 (1.13)	11.0 (1.12)			
	3000						11.8 (1.20)	11.3 (1.16)	11.1 (1.13)			
	2500						14.5 (1.47)	13.0 (1.33)	12.0 (1.23)	11.4 (1.16)		
	2000					21.9 (2.23)	17.1 (1.74)	14.5 (1.48)	12.9 (1.32)	11.9 (1.21)	11.2 (1.14)	10.5 (1.07)
	1500						19.8 (2.02)	16.1 (1.64)	13.9 (1.42)	12.4 (1.27)	11.4 (1.16)	10.8 (1.10)
	1000					21.8 (2.23)	17.4 (1.78)	14.7 (1.50)	13.0 (1.32)	11.6 (1.19)	11.2 (1.14)	
	500					22.0 (2.25)	23.0 (2.34)	18.3 (1.87)	15.3 (1.57)	13.3 (1.36)	11.7 (1.19)	11.3 (1.16)
	0					26.9 (2.74)	23.2 (2.36)	18.6 (1.90)	15.6 (1.59)	13.3 (1.36)	11.4 (1.17)	11.4 (1.16)
	-500			18.1 (1.85)	22.7 (2.31)	28.6 (2.91)	22.6 (2.30)	18.4 (1.88)	15.3 (1.57)	13.0 (1.32)		
	-1000	14.2 (1.45)	23.9 (2.44)	25.3 (2.58)	31.0 (3.16)	26.4 (2.70)	21.3 (2.17)	17.5 (1.78)	14.5 (1.48)	11.9 (1.21)		
	-1500	17.5 (1.78)	30.2 (3.08)	33.3 (3.40)	29.7 (3.03)	23.5 (2.39)	19.1 (1.95)	15.7 (1.60)	12.8 (1.30)			
	-2000			31.8 (3.25)	23.8 (2.43)	19.2 (1.96)	15.7 (1.61)	12.6 (1.28)				
	-2500				15.2 (1.55)	12.7 (1.30)	9.8 (1.00)					

Lifting capacity of the excavator

Lifting capacity over front end, dozer down

MODEL	U48-4	SPECIFICATION	CAB VERSION WITH RUBBER CRAWLER
	KBM		ARM 1450 mm

LIFT POINT HEIGHT [mm]	LIFT POINT RADIUS (mm)											kN (t)	
	Minimum	1500	2000	2500	3000	3500	4000	4500	Maximum				
GL	4000							7.9 (0.81)					
	3500							7.7 (0.79)	8.0 (0.82)				
	3000							8.2 (0.84)	8.1 (0.83)	8.2 (0.84)	8.3 (0.85)		
	2500						10.0 (1.02)	9.1 (0.93)	8.6 (0.88)	8.3 (0.85)	8.3 (0.85)		
	2000					15.6 (1.59)	12.1 (1.24)	10.4 (1.06)	9.3 (0.95)	8.7 (0.89)	8.4 (0.86)		
	1500						14.5 (1.48)	11.7 (1.20)	10.1 (1.03)	9.2 (0.93)	8.6 (0.87)		
	1000						16.4 (1.67)	12.9 (1.32)	10.9 (1.11)	9.6 (0.98)	8.7 (0.89)		
	500					16.7 (1.71)	17.5 (1.79)	13.8 (1.41)	11.5 (1.17)	9.9 (1.01)	8.9 (0.90)		
	0					21.6 (2.21)	17.9 (1.83)	14.2 (1.45)	11.8 (1.20)	10.1 (1.03)	9.1 (0.92)		
	-500		15.0 (1.53)	15.0 (1.53)	18.7 (1.90)	22.8 (2.33)	17.6 (1.80)	14.1 (1.44)	11.7 (1.19)	9.8 (1.00)	9.2 (0.94)		
	-1000		20.4 (2.08)	21.5 (2.20)	26.5 (2.70)	21.3 (2.17)	16.7 (1.71)	13.5 (1.38)	11.1 (1.13)				
	-1500		26.5 (2.70)	29.1 (2.97)	25.0 (2.55)	19.0 (1.94)	15.1 (1.54)	12.1 (1.24)					
	-2000		36.8 (3.75)	29.3 (2.99)	19.9 (2.03)	15.4 (1.57)	12.1 (1.24)						
-2500						8.8 (0.90)							

Lifting capacity over front end, dozer down

MODEL	U48-4	SPECIFICATION	CAB VERSION WITH STEEL CRAWLER
	KBM		ARM 1450 mm

LIFT POINT HEIGHT [mm]	LIFT POINT RADIUS (mm)											kN (t)	
	Minimum	1500	2000	2500	3000	3500	4000	4500	Maximum				
GL	4000							7.9 (0.81)					
	3500							7.7 (0.79)	8.0 (0.82)				
	3000							8.2 (0.84)	8.1 (0.83)	8.2 (0.84)	8.3 (0.85)		
	2500						10.0 (1.02)	9.1 (0.93)	8.6 (0.88)	8.3 (0.85)	8.3 (0.85)		
	2000					15.6 (1.59)	12.1 (1.24)	10.4 (1.06)	9.3 (0.95)	8.7 (0.89)	8.4 (0.86)		
	1500						14.5 (1.48)	11.7 (1.20)	10.1 (1.03)	9.2 (0.93)	8.6 (0.87)		
	1000						16.4 (1.67)	12.9 (1.32)	10.9 (1.11)	9.6 (0.98)	8.7 (0.89)		
	500					16.7 (1.71)	17.5 (1.79)	13.8 (1.41)	11.5 (1.17)	9.9 (1.01)	8.9 (0.90)		
	0					21.6 (2.21)	17.9 (1.83)	14.2 (1.45)	11.8 (1.20)	10.1 (1.03)	9.1 (0.92)		
	-500		15.0 (1.53)	15.0 (1.53)	18.7 (1.90)	22.8 (2.33)	17.6 (1.80)	14.1 (1.44)	11.7 (1.19)	9.8 (1.00)	9.2 (0.94)		
	-1000		20.4 (2.08)	21.5 (2.20)	26.5 (2.70)	21.3 (2.17)	16.7 (1.71)	13.5 (1.38)	11.1 (1.13)				
	-1500		26.5 (2.70)	29.1 (2.97)	25.0 (2.55)	19.0 (1.94)	15.1 (1.54)	12.1 (1.24)					
	-2000		36.8 (3.75)	29.3 (2.99)	19.9 (2.03)	15.4 (1.57)	12.1 (1.24)						
-2500						8.8 (0.90)							

Lifting capacity over front end, dozer down

MODEL	U55-4	SPECIFICATION	CAB VERSION WITH RUBBER CRAWLER
	KBM		ARM 1570 mm

kN (t)

LIFT POINT HEIGHT [mm]	LIFT POINT RADIUS (mm)											
	Minimum	1000	1500	2000	2500	3000	3500	4000	4500	5000	Maximum	
GL	4000								11.3 (1.16)			
	3500								11.2 (1.14)	11.1 (1.14)	11.2 (1.15)	
	3000								12.0 (1.23)	11.5 (1.18)	11.2 (1.15)	
	2500						14.9 (1.52)	13.3 (1.36)	12.3 (1.25)	11.6 (1.18)	11.2 (1.14)	10.5 (1.07)
	2000					23.3 (2.38)	17.8 (1.82)	15.0 (1.53)	13.3 (1.36)	12.2 (1.24)	11.4 (1.16)	10.6 (1.08)
	1500						20.8 (2.12)	16.7 (1.71)	14.3 (1.46)	12.8 (1.30)	11.7 (1.19)	10.9 (1.11)
	1000						23.1 (2.35)	18.2 (1.86)	15.3 (1.56)	13.4 (1.36)	12.0 (1.22)	11.3 (1.16)
	500						24.2 (2.47)	19.1 (1.95)	15.9 (1.63)	13.7 (1.40)	12.1 (1.23)	11.5 (1.17)
	0					24.6 (2.51)	24.4 (2.49)	19.5 (1.99)	16.2 (1.65)	13.8 (1.41)	11.9 (1.21)	11.6 (1.18)
	-500			18.1 (1.85)	21.8 (2.23)	30.1 (3.07)	23.7 (2.41)	19.2 (1.96)	16.0 (1.63)	13.5 (1.38)		
	-1000	14.4 (1.47)	24.2 (2.47)	25.1 (2.57)	30.0 (3.06)	27.8 (2.83)	22.2 (2.27)	18.2 (1.86)	15.1 (1.54)	12.5 (1.27)		
	-1500	17.7 (1.80)	30.3 (3.10)	33.0 (3.36)	31.3 (3.20)	24.6 (2.51)	19.9 (2.04)	16.4 (1.67)	13.4 (1.37)			
	-2000			34.5 (3.52)	25.0 (2.55)	20.1 (2.05)	16.4 (1.68)	13.3 (1.35)				
	-2500				15.8 (1.61)	13.3 (1.36)	10.5 (1.07)					

Lifting capacity over front end, dozer down

MODEL	U55-4	SPECIFICATION	CAB VERSION WITH STEEL CRAWLER
	KBM		ARM 1570 mm

kN (t)

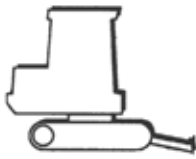
LIFT POINT HEIGHT [mm]	LIFT POINT RADIUS (mm)											
	Minimum	1000	1500	2000	2500	3000	3500	4000	4500	5000	Maximum	
GL	4000								11.3 (1.16)			
	3500								11.2 (1.14)	11.1 (1.14)	11.2 (1.15)	
	3000								12.0 (1.23)	11.5 (1.18)	11.2 (1.15)	
	2500						14.9 (1.52)	13.3 (1.36)	12.3 (1.25)	11.6 (1.18)	11.2 (1.14)	10.5 (1.07)
	2000					23.3 (2.38)	17.8 (1.82)	15.0 (1.53)	13.3 (1.36)	12.2 (1.24)	11.4 (1.16)	10.6 (1.08)
	1500						20.8 (2.12)	16.7 (1.71)	14.3 (1.46)	12.8 (1.30)	11.7 (1.19)	10.9 (1.11)
	1000						23.1 (2.35)	18.2 (1.86)	15.3 (1.56)	13.4 (1.36)	12.0 (1.22)	11.3 (1.16)
	500						24.2 (2.47)	19.1 (1.95)	15.9 (1.63)	13.7 (1.40)	12.1 (1.23)	11.5 (1.17)
	0					24.6 (2.51)	24.4 (2.49)	19.5 (1.99)	16.2 (1.65)	13.8 (1.41)	11.9 (1.21)	11.6 (1.18)
	-500			18.1 (1.85)	21.8 (2.23)	30.1 (3.07)	23.7 (2.41)	19.2 (1.96)	16.0 (1.63)	13.5 (1.38)		
	-1000	14.4 (1.47)	24.2 (2.47)	25.1 (2.57)	30.0 (3.06)	27.8 (2.83)	22.2 (2.27)	18.2 (1.86)	15.1 (1.54)	12.5 (1.27)		
	-1500	17.7 (1.80)	30.3 (3.10)	33.0 (3.36)	31.3 (3.20)	24.6 (2.51)	19.9 (2.04)	16.4 (1.67)	13.4 (1.37)			
	-2000			34.5 (3.52)	25.0 (2.55)	20.1 (2.05)	16.4 (1.68)	13.3 (1.35)				
	-2500				15.8 (1.61)	13.3 (1.36)	10.5 (1.07)					

Lifting capacity of the excavator

Lifting capacity over front end, dozer down

MODEL	U55-4	SPECIFICATION	CAB VERSION WITH WIDE STEEL CRAWLER
	KBM		ARM 1570 mm

LIFT POINT HEIGHT [mm]	LIFT POINT RADIUS (mm)											kN (t)
	Mini-mum	1000	1500	2000	2500	3000	3500	4000	4500	5000	Maximum	
GL	4000								11.3 (1.16)			
	3500							11.2 (1.14)	11.1 (1.14)	11.2 (1.15)		
	3000							12.0 (1.23)	11.5 (1.18)	11.2 (1.15)		
	2500						14.9 (1.52)	13.3 (1.36)	12.3 (1.25)	11.6 (1.18)	11.2 (1.14)	10.5 (1.07)
	2000					23.3 (2.38)	17.8 (1.82)	15.0 (1.53)	13.3 (1.36)	12.2 (1.24)	11.4 (1.16)	10.6 (1.08)
	1500						20.8 (2.12)	16.7 (1.71)	14.3 (1.46)	12.8 (1.30)	11.7 (1.19)	10.9 (1.11)
	1000						23.1 (2.35)	18.2 (1.86)	15.3 (1.56)	13.4 (1.36)	12.0 (1.22)	11.3 (1.16)
	500						24.2 (2.47)	19.1 (1.95)	15.9 (1.63)	13.7 (1.40)	12.1 (1.23)	11.5 (1.17)
	0					24.6 (2.51)	24.4 (2.49)	19.5 (1.99)	16.2 (1.65)	13.8 (1.41)	11.9 (1.21)	11.6 (1.18)
	-500			18.1 (1.85)	21.8 (2.23)	30.1 (3.07)	23.7 (2.41)	19.2 (1.96)	16.0 (1.63)	13.5 (1.38)		
	-1000	14.4 (1.47)	24.2 (2.47)	25.1 (2.57)	30.0 (3.06)	27.8 (2.83)	22.2 (2.27)	18.2 (1.86)	15.1 (1.54)	12.5 (1.27)		
	-1500	17.7 (1.80)	30.3 (3.10)	33.0 (3.36)	31.3 (3.20)	24.6 (2.51)	19.9 (2.04)	16.4 (1.67)	13.4 (1.37)			
	-2000			34.5 (3.52)	25.0 (2.55)	20.1 (2.05)	16.4 (1.68)	13.3 (1.35)				
	-2500				15.8 (1.61)	13.3 (1.36)	10.5 (1.07)					

Accessories

The accessories approved for this excavator by the respective countries are described in the following segments. For further accessories, please contact your KUBOTA dealer or authorized retailer.



Accessories from other manufacturers may only be fitted after prior written approval from KUBOTA. Also see the "Approved use" section (page 16).

KUBOTA Rotary beacon

An optional rotary beacon (1) is available as an accessory. The beacon is mounted at the rear end of the cab roof with a clip-on pedestal (2).

The rotary beacon is switched on and off with the rotary beacon switch. See the "Right control console" section (page 47) for details.

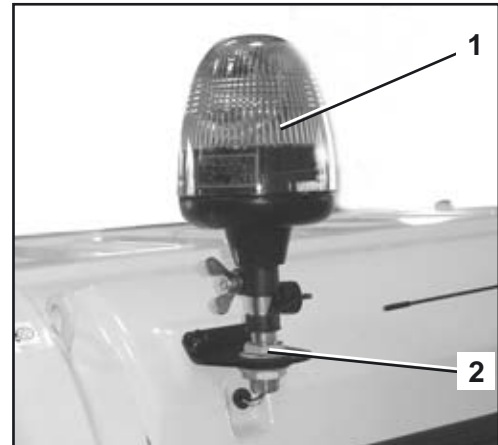

KUBOTA Pipe safety valve

The pipe safety valve prevents the load from suddenly lowering during lifting in case a pipe or hose bursts.

Excavators that will be used in the lifting operation, must be equipped with at least a pipe safety valve on the boom and arm, together with an overload warning function (page 28) according to EN 474-5.

An additional pipe safety valve in accordance with EN 474-1 must be installed before using the dozer for lifting operation support.

The pipe safety valve can be factory mounted or retrofitted by your KUBOTA dealer.

The pipe safety valve is adjusted in the factory on the particular excavator.

Manipulating the pipe safety valve will void the warranty.



Any manipulation can result in substantial personal injuries, even death, and is therefore strictly forbidden.

The manipulation and repair of the pipe safety valves is forbidden. They may only be replaced by your KUBOTA dealer as a kit.

Accessories

Note on use

- Check the pipe safety valve before using the excavator. Do not carry out any excavating work if the pipe safety valve is damaged.
- In case machines equipped with a warning device experience an overload, the boom must be lowered until the load rests on the ground. To prevent personal injuries and damage to equipment, do not operate any other functions (e.g. moving the swivel frame).
- It is not allowed to swing the boom during lifting operation.

KUBOTA Quick coupling systems and equipments

The quick coupling system is designed to be mounted with pins at the arm and the bucket linkage. It is designed to receive KUBOTA bucket accessories only.

The related operating instructions are attached to the excavator's operating instructions.

For further information, please contact your KUBOTA dealer or authorized retailer.



The size, weight and arm bracket of the excavator are important factors in the selection of attachments. These factors must be made known to the attachment manufacturer when ordering attachments, and be observed by the operator when operating the excavator. Various attachments are nevertheless of limited use only.

KUBOTA Bucket accessories

For further bucket accessories, please contact your KUBOTA dealer or authorized retailer.

Replacing the bucket



When replacing the bucket, make sure to wear an eye protection, a safety helmet and protective gloves.



During attaching and detaching, chippings and burrs may occur at the bolts or bushings. These may cause severe injuries.



Never use your fingers for the alignment of the components (bucket linkage, bucket, arm). The components may sever your fingers by uncontrolled movements.

Remove the bucket

- Set the bucket down on flat, level ground.
- Stop the engine.
- Ensure that the components listed below remain free of dirt and dust.
- Unscrew the bolt locks on the bolts (2) and (3)..



The bucket is mounted with the bolts (2) and (3) in a total of four bearing eyes. There is an O-ring on each bearing eye.

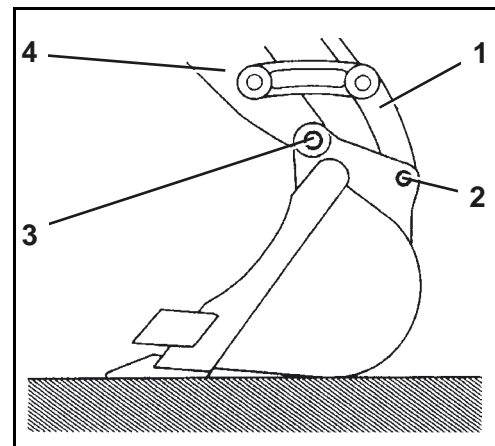

- Pull the O-ring (6) out of the groove on the bearing eye (5).

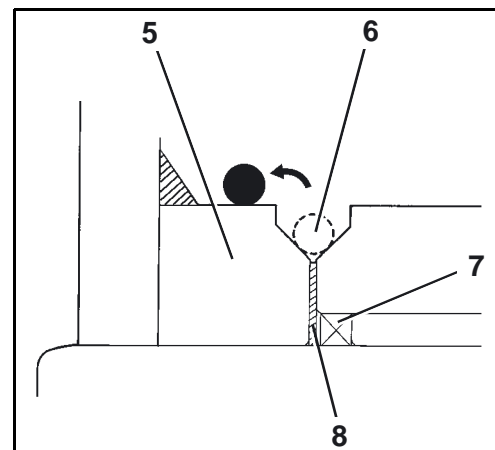

- Remove the bolts (2) and (3) from the bearing bores.
- Ensure that the spacers (previous figure/8) do not get lost.

Start the engine and raise the arm or boom until the bucket is released.

If a new bucket is not to be mounted immediately, insert the O-rings, bolts and spacers into the bearing bores and secure them from loss using the bolt locks.

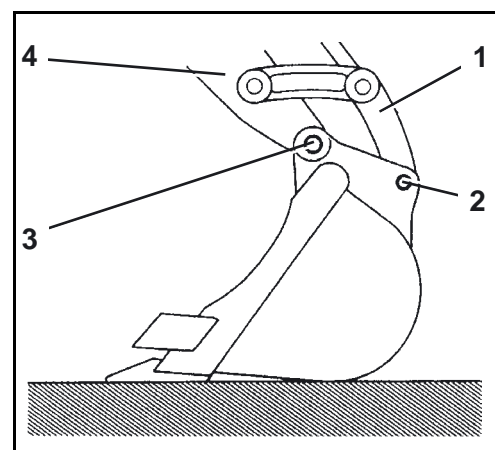

Accessories

Install the bucket

- Ensure that the components listed below are free of dirt and dust.
- Ensure that there is an O-ring (6) attached to each bearing eye (5).
- Check O-rings and dust protection seals (7) for damage, replace if necessary.

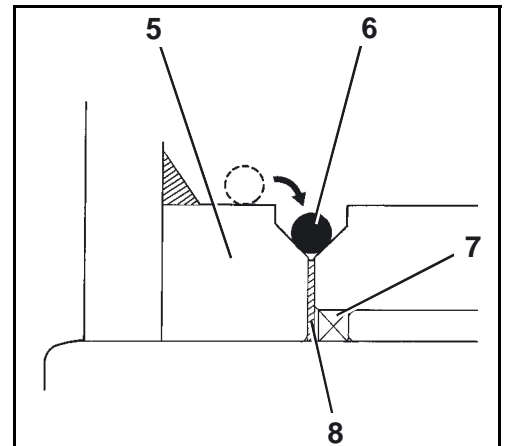

- Align the bearing bore of the arm (4) to the bearing bore (3) on the bucket.
- Insert a spacer (previous figure/8) on each side of the arm bearing (3).
- Push the bolts (3) into the bearing bore.
- Align the bucket linkage (1) to the bearing bore (2) on the bucket.

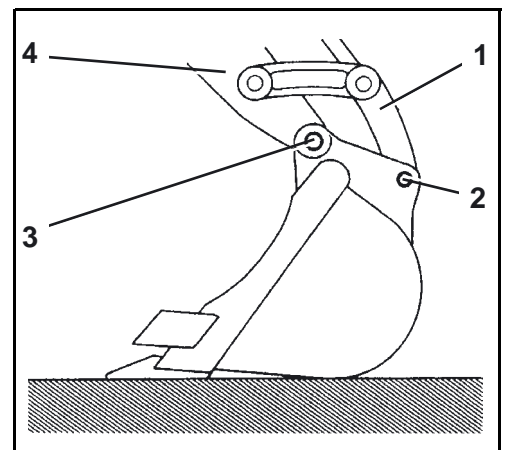

The axial free play must be within 0.6 mm. If the free play is greater, insert suitable spacers.

- Push the bolt into the bearing bore.
- Screw the bolt locks on in order to keep the bolts in position.
- Insert the O-rings of the bearing eyes downwards in the groove.



The O-ring protects the spacer from dirt and any resulting wear.

- Ensure that the O-ring sits completely in the groove.
- Lubricate the bolts with grease.

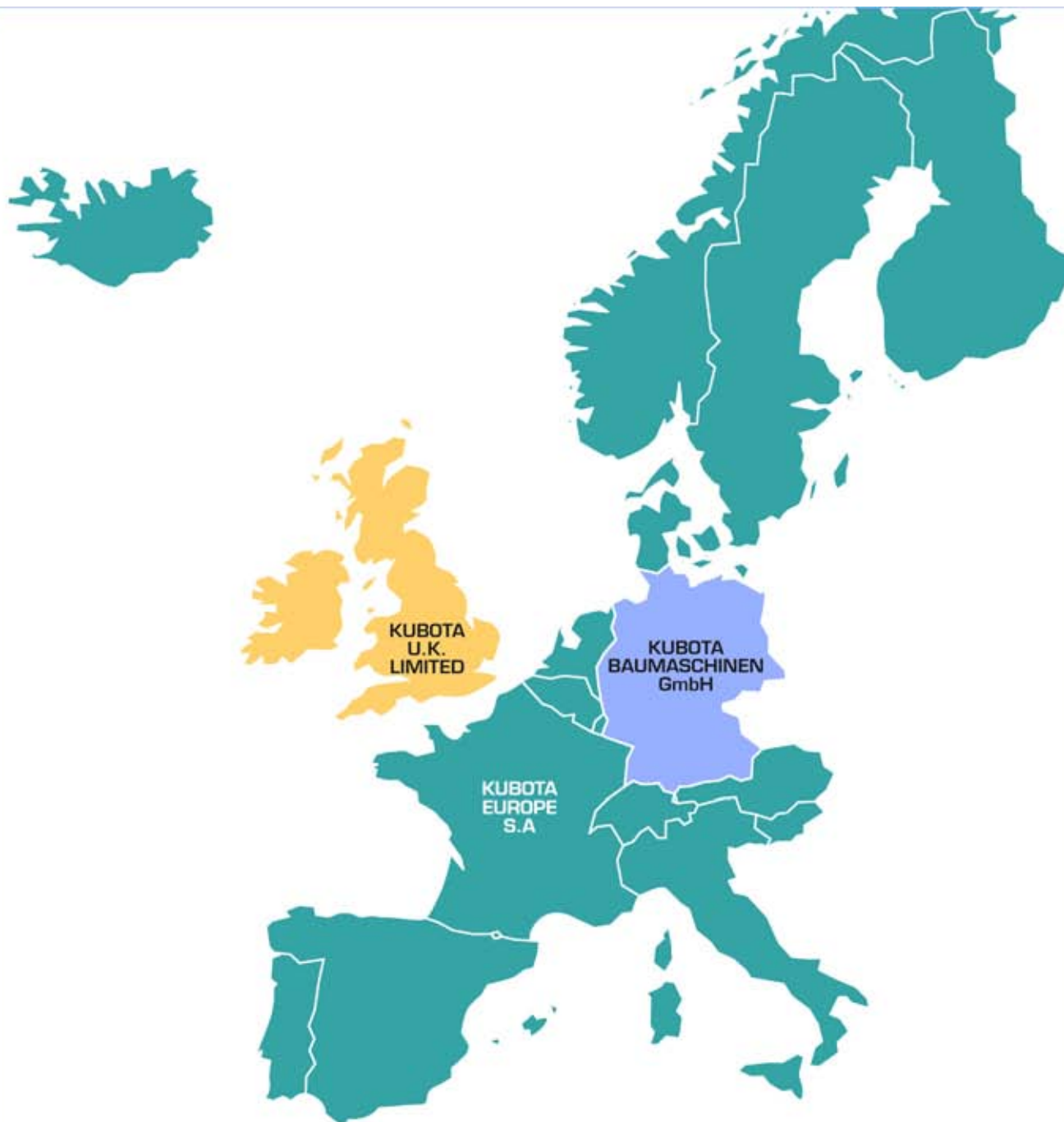

KUBOTA EUROPE S.A.

19-25, rue Jules Verdecruysse - BP 50088, Z.I.
95101 Argenteuil Cedex France
Tel. +33 (0)1 34 26 34 34 - Fax. +33 (0)1 34 26 34 21
www.kubota.fr

KUBOTA BAUMASCHINEN GmbH

Steinhauser Straße 100
66482 Zweibrücken
Tel. : +49 (0)6332 48 70 - Fax : +49 (0)6332 48 71 01
www.kubota-baumaschinen.de

KUBOTA U.K. LIMITED

Dormer Road, Thame Oxfordshire, OX9 3UN
Phone : +44 (0)184 421 4500 - Fax : +44 (0)184 421 6685
www.kubota.co.uk