

Kubota

MINI EXCAVATOR

GB

MODELS

KX015-4

KX016-4

KX018-4

KX019-4



OPERATING INSTRUCTIONS

Dear valued customer,

please fill in the form below. Your information will help us to help you.

<p>Type:</p> <p>Year of construction:</p> <p>Serial #:</p> <p>Shipment date:</p>
--

Please contact your KUBOTA dealer for any additional information or troubleshooting procedures not mentioned in these operating instructions.

We also point out that the contents of these operating instructions are not part of an earlier existing agreement, promise or legal relationship or amend this. All responsibilities arise of the respective sales contract containing the complete and exclusively valid contractual warranty, refer to the "Duties, liability and warranty" section (page 13). This documentation does neither extend nor restrict the contractual warranty.

KUBOTA Baumaschinen GmbH reserves the right to change the information contained in this document with respect to future technical development without altering the basic characteristics of the excavators described herein and without amending this document.

Distribution and reproduction of this documentation and disclosure of its content are not allowed unless expressly approved by the manufacturer. Violators of the above terms are liable for compensation for damages.

Table of contents

Abbreviations.....	8
General symbols	8
General information	11
Foreword	11
EC declaration of conformity	11
Date of issue of the operating instructions	12
Operating personnel.....	12
Location of the operating instructions.....	12
Spare parts.....	12
Safety rules	13
Basic safety instructions.....	13
Duties, liability and warranty.....	13
Safety symbols.....	14
Approved use	15
Unapproved use	15
Special duties of the owner	16
Noise emission and vibration	17
Noise emission	17
Vibrations	17
Safety labels on the excavator	18
Safety devices	25
Locking the controls	25
Engine stop knob	25
Protective structure canopy and cab.....	26
Emergency hammer.....	27
Locking of the swivel frame.....	27
Hazards coming from the hydraulic system	27
Fire protection	28
Recovery, loading and transport	29
Safety rules for recovery	29
Safety rules while loading with a crane	29
Safety rules for transport.....	30
Recovery	31
Hoisting the excavator with a crane	31
Transport on a flat bed trailer	33
Description of the excavator	35
Model overview	35
Dimensions.....	36
Dimensions KX015-4	36
Dimensions KX016-4, KX018-4 and KX019-4	37
Specifications	39
Specifications KX015-4/KX016-4	39
Specifications KX018-4/KX019-4	40
Identification of the excavator.....	41
Serial # of the machine	41
Engine number.....	42
Equipment	42
Standard equipment.....	42

Assembly and functions	43
Component overview	43
Operator's place	44
Left control console	44
Description of the components of the left control console	44
Drive levers and control pedals	45
Drive levers and control pedals – description	45
Right control console	46
Description of the components of the right control console	46
Display and control unit - description	48
Other equipment at the operator's place	49
Interior lighting	49
Fuse box	49
Tool compartment	49
Cup holder	50
Funnel for diesel fuel.....	50
Extendable track width (KX016-4/KX018-4/KX019-4)	50
Other equipment to be found at the machine	51
Main battery.....	51
Battery cut-off switch	51
Return change valve for direct return flow.....	51
Tank filler neck and fill level monitor.....	52
Rear view mirror	52
Heating and ventilation (cab version)	52
Engine compartment	54
Hydraulic system	55
Coolant radiator and oil cooler.....	56
Operation	57
Safety rules for operation	57
Guiding the operator.....	58
Working in the vicinity of overhead power lines.....	58
Working in the vicinity of underground power lines	58
Initial operation	59
Explanation of the display indications.....	59
Setting the clock	59
Running-in of the excavator.....	60
Special maintenance instructions	60
Operating the excavator	60
Pre-operational services.....	60
Checking the engine oil level	60
Checking the coolant level.....	61
Checking coolant radiator and oil cooler.....	61
Checking of the V-belt.....	61
Checking the exhaust system for leaks	62
Checking the oil level of the hydraulic system	62
Greasing the bucket bolts and bucket linkage bolts.....	62
Greasing the swing bracket	63
Other greasing points.....	63
Checking the electric cables and connections	63
Check the fuel level.....	64
Check the fluid level of the washer system (cab version)	64
Setting up the workplace	64
Getting on the excavator	64
Adjusting the operator's seat (KX015-4/KX016-4)	65
Horizontal seat adjustment (seat stand-off).....	65
Spring adjustment (operator's weight).....	65
Backrest adjustment.....	65

Adjusting the operator's seat (KX018-4/KX019-4).....	65
Horizontal seat adjustment (seat stand-off)	65
Spring adjustment (operator's weight)	66
Backrest adjustment.....	66
Seat belt.....	66
Rear view mirrors adjustment.....	66
Safety instructions for starting the engine	67
Starting the engine	67
Stopping the engine	69
Observation of the displays after starting and during operation.....	69
Adjusting of the track width (KX016-4/KX018-4/KX019-4)	72
Adjusting of the dozer width (KX016-4/KX018-4/KX019-4)	72
Set blade width to narrow track width	72
Set blade width to standard track width	73
Driving the excavator	73
Driving.....	74
Turning	75
During driving	75
From a standing position.....	75
Turning on the spot	76
Driving uphill and downhill	76
Notes for rubber crawler operation	77
Making sharp turns.....	77
Protecting the crawler against salt	77
Operating the controls during excavation work	77
Note on using wider and deeper buckets	78
Operating the dozer.....	78
Overview of control lever functions.....	79
Operating the boom.....	79
Operating the arm.....	80
Operating the bucket	80
Swivelling the swivel frame.....	81
Swinging the boom	82
Operating of the auxiliary port (KX015-4/KX016-4/KX018-4)	82
Operating of the auxiliary port (KX019-4)	83
Activating the auxiliary port function.....	84
One way hold operation	84
Operating modes.....	85
Flow rate setting.....	86
Return change valve for direct return flow.....	90
Pressure relief of the hydraulic system.....	90
Pressure relief of the auxiliary port (KX019-4).....	91
Placing out of operation.....	92
Operating the heating system (cab version).....	93
Operating the wiper/washer system (cab version)	94
Switching on the windscreen wiper	94
To turn on the washer system.....	95
Operating the interior light (cab version)	95
Operating the rotary beacon (accessories)	95
Operating the 12 V plug	96
Opening and closing the cab door (cab version).....	96
Opening the cab door from outside	96
Closing the cab door	96
Opening the cab door from the inside	97
Opening and closing the windows (cab version).....	97
Front window.....	97
Side window	98
Operating the working lights (optional for KX015-4/KX016-4).....	98

Cold weather operation	99
Necessary preparations prior to the winter season	99
Operation during the winter season.....	99
Jump-starting the excavator	100
Operating in emergency situations	101
Engine stop knob.....	101
Manual lowering of the front attachments.....	101
Filling up the washer system	102
Refuelling the excavator	102
Fill level monitor when refuelling	103
Bleeding the fuel system	103
Replacing the fuses	104
Fuse layout of the fuse box	105
Main fuses	105
Operating the battery cut-off switch.....	106
Opening and closing the engine compartment cover	106
Opening/closing the side cover	107
Replacing the bucket.....	107
Anti-theft system.....	108
Black (individual) key.....	108
Red key (for registering).....	108
The key system	109
Registering a black key for the machine.....	110
Troubleshooting.....	112
Safety rules for troubleshooting.....	112
Troubleshooting: Before operation	112
Troubleshooting: Operation	113
Troubleshooting: Display indications	114
Maintenance	117
Safety rules for maintenance.....	117
Personnel requirements	117
Maintenance interval display	118
General maintenance chart: 50 to 500 hours of operation	119
General maintenance chart: 550 to 1000 hours of operation	120
Servicing maintenance chart: 50 to 500 hours of operation	121
Servicing maintenance chart: 550 to 1000 hours of operation	122
Cleaning the excavator.....	123
Servicing.....	123
Refilling coolant.....	123
Cleaning the Coolant Radiator and the Oil Cooler	124
Checking, Adjusting and Changing the V-Belt.....	125
Checking the coolant hoses	125
Replacing the coolant.....	125
Replacing the engine oil and oil filter.....	126
Draining the engine oil	127
Replacing the oil filter.....	127
Filling the engine oil	127
Checking, cleaning and replacing the air filter.....	128
Replacing the fuel filter	129
Checking and cleaning the water separator	129
Draining the fuel tank.....	130
Checking the fuel lines and the air intake hoses	130
Replacing the return filter in the hydraulic oil tank.....	131
Replacing the suction filter in the hydraulic oil tank.....	131
Topping up/changing the hydraulic oil.....	132
Draining the hydraulic oil.....	133
Filling the hydraulic oil.....	133

Battery service	134
Checking the battery.....	134
Charging the battery	134
Installing/uninstalling and replacing the battery	135
Lubrication.....	136
Greasing the swivel gear	136
Greasing the pitch bearing.....	136
Greasing the swing bracket	137
Other greasing points	137
Checking and tensioning the crawler tension.....	138
Checking the crawler tension.....	138
Adjusting the crawler tension.....	139
Replace the drive unit oil	139
Check, clean and replace the fresh air filter	140
Checking the pipes and hoses of the heating system	141
Changing the Line Filter	141
Changing the auxiliary valve filter	142
Checking the bolted joints	143
Tightening torque for screws	143
Tightening torque for hose clamps	143
Tightening torque for hydraulic hoses	144
Tightening torque for hydraulic pipes	144
Tightening torque for hydraulic adapters.....	144
Recommended lubricants.....	145
Excavator repairs	146
Safety inspection.....	147
Taking out of service and storage	148
Safety rules for taking out of service and storage	148
Storage conditions.....	148
Measures before taking out of service	148
Measures during taking out of service.....	148
Start-up after taking out of service	149
Lifting capacity of the excavator	150
Constructive calculation of lifting capacity.....	150
Lifting attachment.....	150
Load suspension device.....	151
Max. lifting load during swivel operation is 360°	152
Accessories	160
KUBOTA Rotary beacon	160
KUBOTA Pipe safety valve	160
Note on use.....	161
KUBOTA Overload warning function.....	161
KUBOTA Gravel guard.....	161
KUBOTA Quick coupling systems and equipments	162
KUBOTA Bucket accessories.....	162
KUBOTA Foot pedal kit.....	162

Abbreviations

1/min	revolutions per minute	kg	kilogramme
%	percent	km/h	kilometre per hour
°	degrees	kN	kilonewton
°C	degree Celsius	kV	kilovolt
A	Ampere	kW	kilowatt
acc.	according	L	litre
API	American Petroleum Institute	L/min	litres per minute
approx.	approximately	LpA	sound pressure level operator's place
ASTM	American Society for Testing and Materials	LwA	measured sound power level
bar	Bar	m	metre
CECE	Committee for European Construction Equipment	m/s ²	metre per square second
CO ₂	carbon dioxide	m ³	cubic metre
dB	decibel	max.	maximum
DIN	Deutsches Institut für Normung (German Institute for Standards)	mm	millimetre
e.g.	for example	MPa	Megapascal
EMC	electromagnetic compatibility	N	Newton
EN	European standard	resp.	respectively
GL	Ground level	s	second
incl.	including	t	ton
ISO	International Organization for Standardization	V	Volt

General symbols



Warning light



Glow indicator



Fuel indicator



Hydraulic oil



Engine oil indicator































Travel speed



Charge indicator



Low speed

	Forward travel		Control lever direction
	Backward travel		Rotary beacon
	Raise boom		Display selector switch
	Lower boom		Auxiliary port indicator
	Arm crowd		Working lights
	Arm dump		Horn
	Bucket crowd		Bolted
	Bucket dump		Released
	Indicator coolant temperature		Fan
	Service interval indicator		Menu button
	Swivel boom (left)		Insert Key
	Swivel boom (right)		Pull out Key
	Dozer up		Set clock indicator
	Dozer down		Extendable track width
	Control lever direction		

General information

Foreword

These operating instructions apply only for KX015-4, KX016-4, KX018-4 and KX019-4 the KUBOTA excavator models complying with the following EC declaration of conformity (page 11).

Safety instructions, the rules and regulations for the use of excavators given in these operating instructions apply to the excavators mentioned in this documentation.

It is the responsibility of the owner(s):

- to ensure local, regional and national regulations are observed,
- to observe the bodies of rules (laws, regulations, guidelines, etc) stated in the operating instructions to ensure safe handling of the equipment,
- to ensure that the operating instructions are always available for the operating personnel and the information, such as notes, warnings and safety rules and regulations, are followed in all points.

The data in the operating instructions apply for all models. Information applying only a certain model or only optional equipment is highlighted e.g. (optional, KX015-4, KX016-4, KX018-4, KX019-4 and KX019-4 SF).

The terms "front" and "direction of travel" refer to the view of the operator when seated on the operator's seat. Forward direction of travel means that the dozer is at the front when driving forwards as shown in the figure.

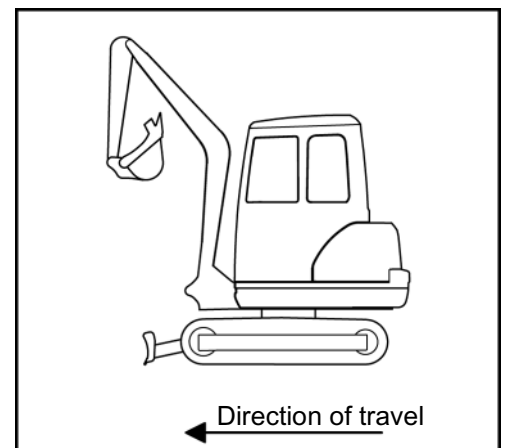

The symbols for operating and safety instructions are listed under "Safety symbols" (page 14).

EC declaration of conformity



With the EC declaration of conformity, KUBOTA Baumaschinen GmbH certifies that the excavator is in conformity with the valid standards and regulations at the time of marketing. The CE conformity marking is located on the type plate and indicates compliance with the regulations.

If the excavator is modified or retrofitted without the approval of the manufacturer, the safety of the excavator may be affected, thus invalidating the EC declaration of conformity.

The EC declaration of conformity is attached to the operating instructions for delivery of the excavator.

Keep the EC declaration of conformity in a safe place and show it, if requested, to the responsible authorities.

Should the EC declaration of conformity get lost, please contact your KUBOTA dealer.

Date of issue of the operating instructions

The date of issue of the operating instructions is printed on the bottom right of the front page of the book.

Operating personnel

The duties of personnel with respect to operation, servicing, repairs and safety inspections must be set forth clearly by the owner.

Personnel in training are allowed to work on or with the excavator only under the supervision of an experienced operator.

Operator

According to industrial safety regulations, only persons who were instructed in the operation of the excavator, who have proven their qualification to the owner (employer) and who can be expected to perform their duties in a reliable way are allowed to operate the excavator independently.

Only trained and instructed personnel are allowed to work on or with the excavator.

Only instructed personnel are allowed to start the excavator and operate the controls.

Trained personnel

Trained personnel are skilled persons with a technical qualification who are able to determine damages to the excavator and perform repairs in their area of qualification (e.g. hydraulic or electrical engineering).

Skilled personnel

Based on their training and experience in their field, skilled personnel must have sufficient knowledge in excavator engineering and be familiar with the applicable national worker's protection regulations, safety regulations and the generally accepted technical rules so that they can assess the safe condition of the excavator.

Location of the operating instructions

The operating instructions must always be kept on the excavator. If the operating instructions have become illegible due to continuous use, the owner (operator) must order a replacement from the manufacturer.

On the face of the seat console below the cover plate, you will find a tray (1) for the operating instructions.

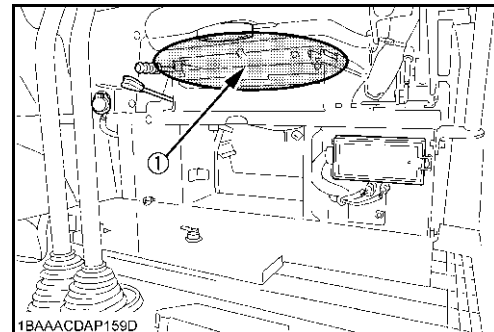

Spare parts

Genuine spare parts can be ordered from KUBOTA dealers by stating the model and the serial # of the excavator.

The item numbers for the spare parts are indicated in the spare parts catalogue.

Safety rules

Basic safety instructions

- The EC machine utilization directive (2009/104/EC) dated 16/09/2009 applies for the operation of the aforementioned excavator.
- The information in these operating instructions applies for maintenance and repairs.
- National rules and regulations apply where applicable.

Duties, liability and warranty

A basic requisite for the safe handling and problem-free operation of the excavator is the knowledge of the safety instructions and safety regulations.

These operating instructions, in particular the safety instructions, must be followed by all persons working near or with the excavator. Above and beyond this, the safety rules and regulations applicable for the site must also be observed.

Hazards occurring during the handling of the excavator:

- The excavators are manufactured according to the state of technology and the recognized safety rules. Nevertheless, danger to the life and limbs of the operator or a third party, or damage to the excavator or to other property can occur. The excavator(s) may only be used
 - for the approved use and
 - in a completely safe operating state.

Malfunctions which can reduce safety must be repaired immediately.

Warranty and liability

The scope, period and form of the warranty are set forth in the sales and delivery conditions of the manufacturer. The operating instructions valid at the time of delivery shall be the basis for any warranty claims arising from errors in the documentation, see the date of issue of the operating instructions (page 12). The following applies above and beyond the sales and delivery conditions: No warranty or liability shall be assumed for personnel and property damages resulting from one or more of the following reasons:

- unapproved use of the excavator,
- improper starting, operation and maintenance of the excavator,
- operation of the excavator with defective safety devices or improperly installed or non-operational safety and protective devices,
- ignorance or non-observance of these operating instructions,
- insufficiently qualified or insufficiently instructed operating personnel,
- improperly performed repairs,
- unauthorised engineering changes to the excavator,
- poor surveillance of machine parts subject to wear,
- catastrophes caused by the effect of foreign objects or an act of God.

The owner must ensure at his own responsibility that

- the safety rules are observed (page 13),
- unapproved use (page 15) and unauthorised operation are excluded and
- the approved use (page 15) is ensured and the excavator is operated in accordance with the contractual conditions of use.

Safety symbols

The following terms and hazard symbols are used in these operating instructions:



Identifies important operating procedure information which may not be immediately evident to the operator.



Identifies operating procedures which must be followed exactly to prevent damage to the excavator or other property.



Identifies operating procedures which must be followed exactly to prevent danger to persons.



Identifies possible hazards in the handling of batteries.



Identifies possible hazards from caustic materials (battery acid).



Identifies possible hazards from explosive materials.



Prohibits the use of fire, ignition sources, and smoking.



Prohibits the spraying of water.



Identifies operating procedures for the proper disposal and storage of ensuing waste materials.

Approved use

The excavators specified in this operator's manual may only be used for to loose the ground, excavating, picking up, transporting and dumping soils, rocks and other materials, for work with the dozer or with a breaker. The load may be transported largely without driving the excavator. Do not exceed the maximum lifting capacity.

Approved use also includes:

- observation of all notes in these operating instructions,
- regular servicing,
- regular safety inspections.

Unapproved use

Any improper use – i.e. any deviation from the information in the "Approved use" section (page 15) of the excavator documented in these operating instructions – is considered an unapproved use. This also applies to the non-observance of the standards and guidelines listed in these operating instructions.

Hazards can occur in case of improper use. Such improper uses include:

- using the excavator to lift loads without suitable load lifting attachments,
- using the excavator in contaminated environments,
- using the excavator in closed rooms without insufficient ventilation,
- using the excavator under conditions of extreme temperatures (extreme heat or cold),
- using the excavator for underground works,
- using the excavator to transport persons in the bucket, and
- using the excavator for tearing down walls with the bucket.

Special duties of the owner

Owner of the excavator in the sense of these operating instructions is any person or company which uses the excavator itself or on whose order it is used. In special cases (e.g. leasing, rental), the owner is the person who must perform the duties arising from operation according to the conditions of the contract between owner and user of the excavator.

The owner must ensure that the excavator is only used properly and that any danger to the life and health of the user or others who are in the proximity of the user are eliminated. Furthermore, observance of the safety rules and regulations as well as the operating, maintenance and repair regulations must be ensured. The owner must make sure that all operators and users have read and understood these operating instructions.

Persons who work with or on the excavator must be provided by the operator with, and where applicable use suitable personal protective equipment (PPE), for example suitable working clothes, safety shoes, safety helmets, eye protection, ear protection and air-filter masks. The owner/employer bears the main responsibility for the PPE, which is specified by the safety rules for particular types of activity.

Waste such as old oil, fuel, hydraulic fluid, coolant and batteries comes under the category of toxic waste and can be a hazard to the environment, people and animals.

Disposal must be undertaken in an appropriate way, according to legally prescribed pollution control and safety regulations.

If you have questions about the correct disposal or storage of refuse and toxic waste, contact your KUBOTA dealer or a local waste management contractor.

Noise emission and vibration

The values specified in this manual have been identified in the test cycle at an identical machine and are valid for a standard equipment machine. The determined values are shown in the Technical Data (page 39).

Noise emission

The noise levels were determined using the method of determining the guaranteed sound pressure level of ISO 4871 based on directive 2000/14/EC, appendix VI.

The noise levels shown are not applicable for the determination of additional workplace noise emissions. The actual noise levels may need to be determined directly at the workplaces, subject to actually existing conditions (other noise sources, special operating conditions, sound reflections).

Depending on the actual noise emissions the owner must provide the necessary personal protective equipment to the operator (ear protection).



*Noise of a noise level of more than 85 dB (A) can cause hearing damage.
From a noise level of 80 dB (A), the use of an ear protection is recommended.
From a noise level of 85 dB (A), the operator must wear an ear protection.*

Vibrations

The vibrations at the machine have been determined at an identical machine.

The vibration stress on the operator over a longer period of time must be determined by the owner at the site of application, in compliance with directive 2002/44/ EC in order to consider individual magnitudes of influence.

Safety labels on the excavator

Keep the safety and warning symbols (labels) on the excavator clean and legible, replacing them if necessary.

The positioning of the safety symbols is illustrated in the following figures.

1) Code #: RG158-5726-0

Danger of cutting from rotating components!

The rotary fan can cut the fingers or sever them.

- Do not reach into rotating components.

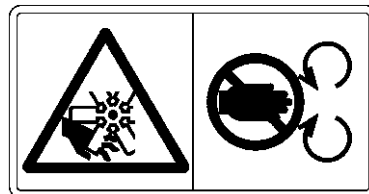

2) Code #: RG158-5721-0

Risk of burns from hot components!

Surfaces can be hot and lead to burns.

- Do not touch hot parts, such as exhaust muffler, etc.

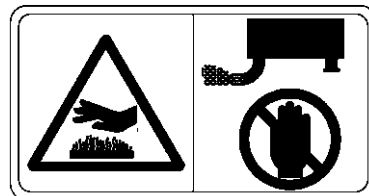

3) Code #: RG158-5723-0

Mortal danger from moving excavator!

When staying in the danger zone and in the case of a suddenly starting excavator, there is the danger of being run over by the excavator.

- Only start the machine from the driver's seat.
- Do not start the machine by joining the starter poles.

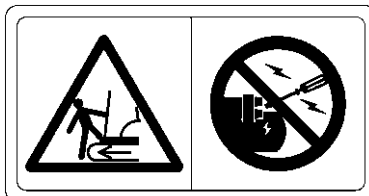

4) Code #: RG158-5727-0

Mortal danger by squashing!

Low safety distance to the excavator and to obstacles can prevent flight from the danger zone. Squashing by excavator results in severe injury or death.

- Do not enter the manoeuvring area.
- Ensure safety distance to obstacles and sufficient freedom of movement.

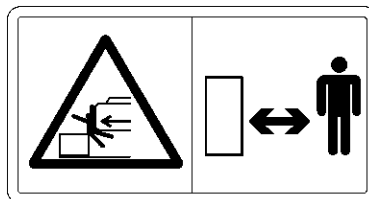

5) Code #: R2491-5736-0

Fire hazard from inflammable diesel fuel!

Inflammatory vapours can occur in the fuel tank, which may go up in flames as a result of an ignition source.

- Do not use open flames in the area of the fuel tank.

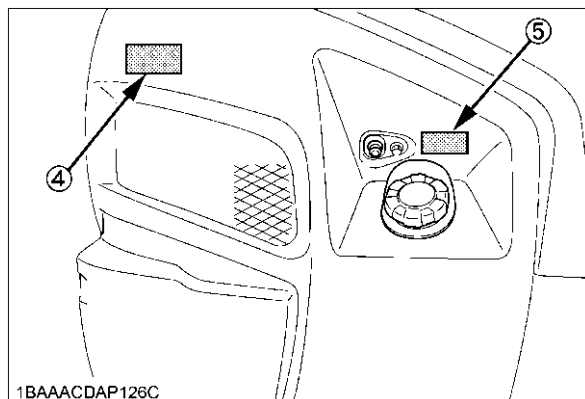
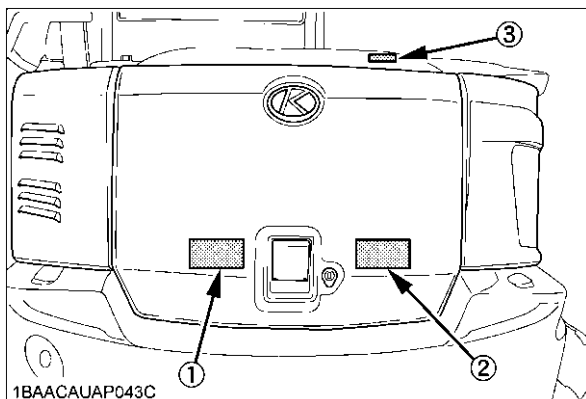
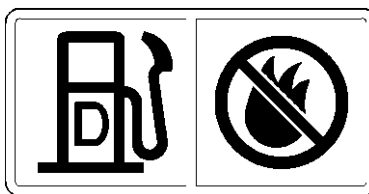

Safety rules

1) Code #: RG158-5724-0

Danger of injury from liquids under pressure!

Escaping hydraulic oil under pressure can penetrate into the skin.

Risk of burns from hot components!

Surfaces can be hot and lead to burns.

- Apertures, e.g., ventilation systems, and hot components, must not be covered with hands.



2) Code #: RG158-5789-0

Danger of cutting from rotating components!

The rotary fan can cut into the extremities.

Danger of squashing from rotating components!

The rotary belt drive can draw in limbs and squash them.

- Do not reach into rotating components.



3) Code #: RG158-5754-0

Risk of fire from hot components!

Escaping liquids can get onto hot components and catch fire.

- Before working on the engine, please read the operating instructions.

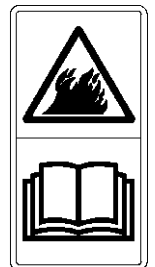

4) Code #: RG158-5785-0

Risk of burns from hot components!

Surfaces can be hot and lead to burns.

- Do not touch hot parts, such as exhaust muffler, etc.

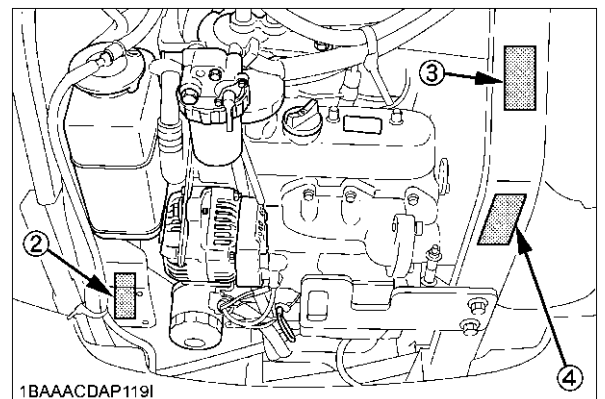
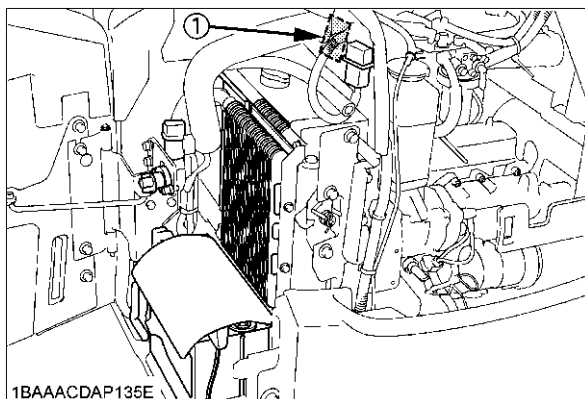

- 1) Code #: R2491-5796-0
Attachment point for lifting gear.

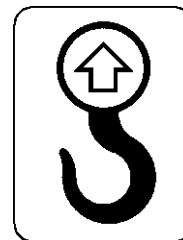

- 2) Code #: RG158-5722-0

Mortal danger by squashing!

Low safety distance to the excavator and to obstacles can prevent flight from the danger zone. Squashing by excavator results in severe injury or death.

- Do not stay in the swivel area of the boom.
- Ensure safety distance to obstacles and sufficient freedom of movement.

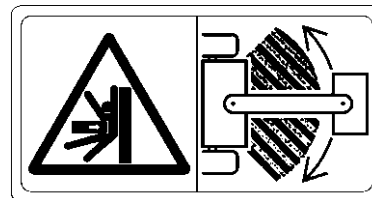

- 3) Code #: RG138-5791-0

Danger of injury from components under pressure!

In the case of improper operating of the crawler tensioner, grease or the pressure valve can splash out under high pressure can lead to injury.

- Before working on the crawler tensioner, please read the operating instructions!

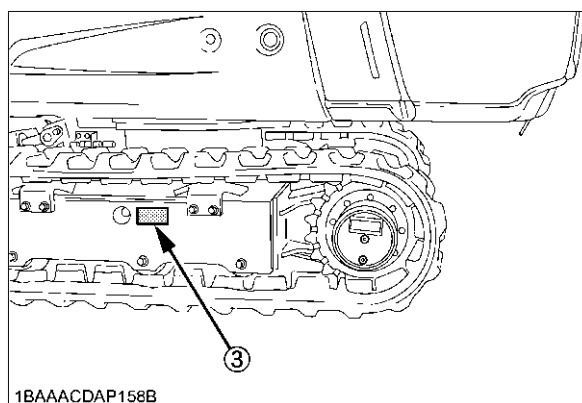
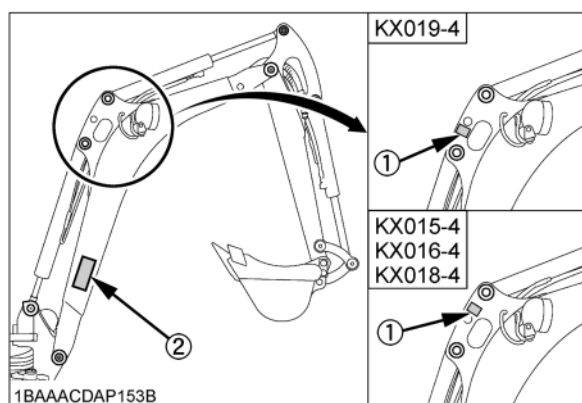
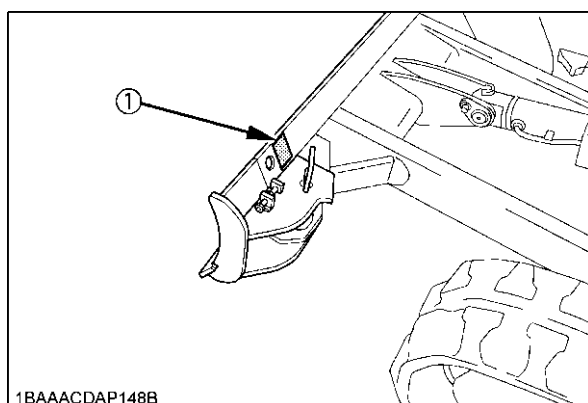
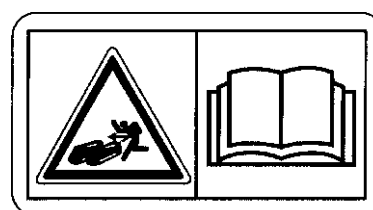

Safety rules

- 1) Code #: RG109-5796-0
Not an attachment point for lifting gear.

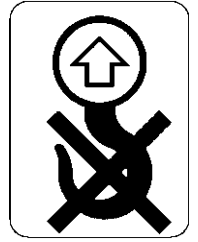

- 2) Code #: RG058-5749-0
KX015-4, KX016-4 (cab)

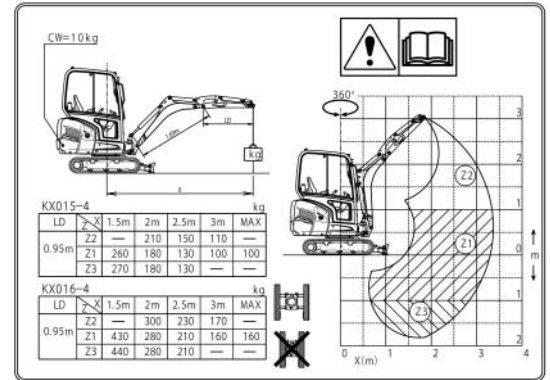

- 2) Code #: RG158-5749-0
KX018-4, KX019-4 (cab)

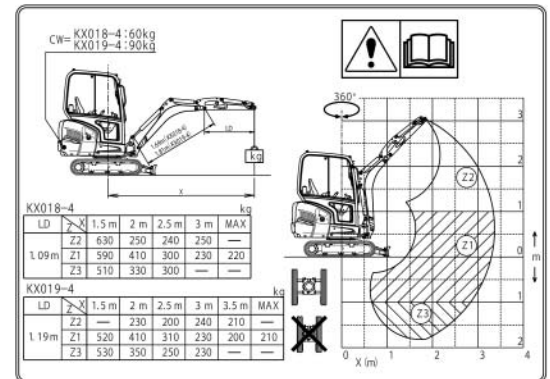

- 2) Code #: RG158-5759-0
KX019-4 SF (cab)

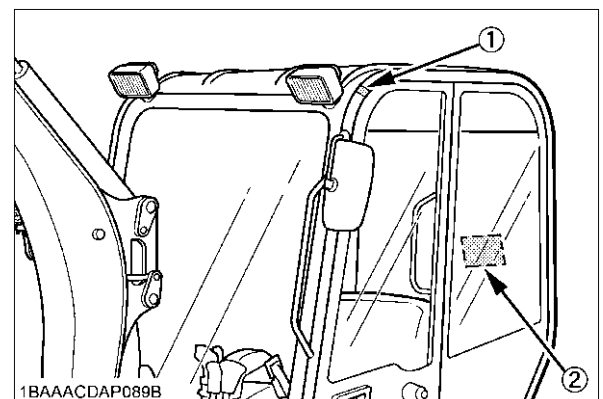
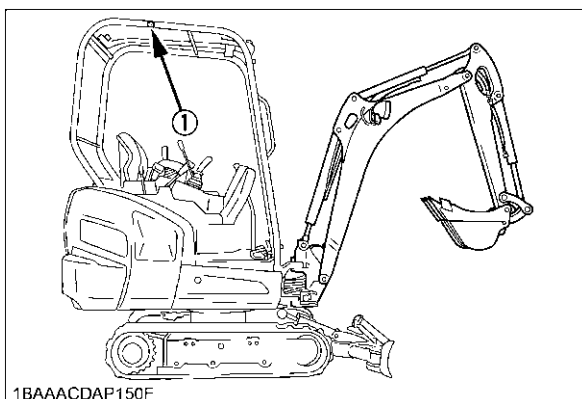
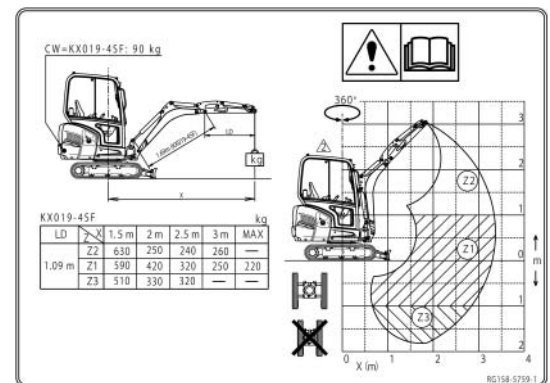

- 1) Code #: RG058-5748-0
KX015-4, KX016-4 (Canopy)

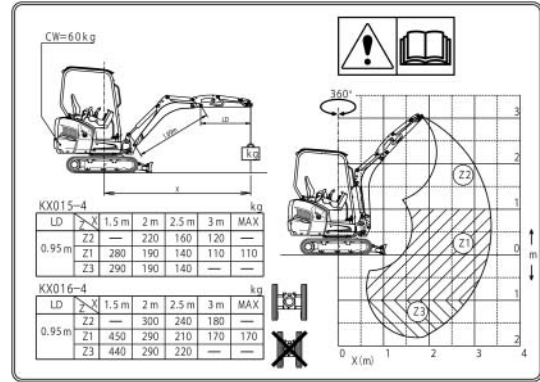

- 1) Code #: RG158-5748-0
KX018-4, KX019-4 (Canopy)

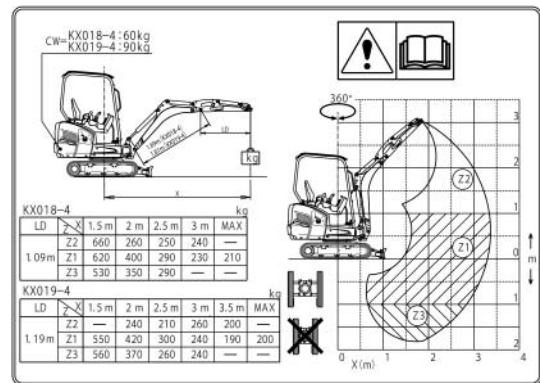

- 1) Code #: RG158-5758-0
KX019-4 SF (Canopy)

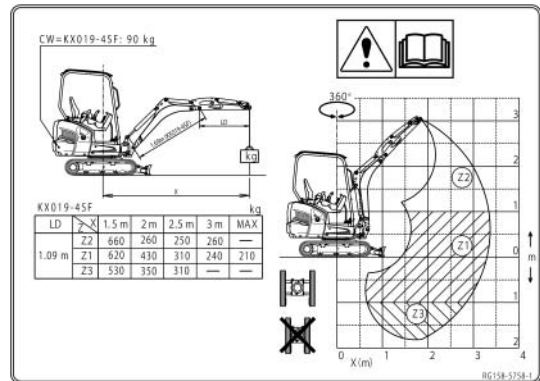

- 2) Code #: RG308-5702-0

Risk of accidents by incorrect operation!

Improper operating can lead to damage to the excavator, to serious accidents with high risk of injury and death as a result.

- Please read the operating instructions before commissioning.

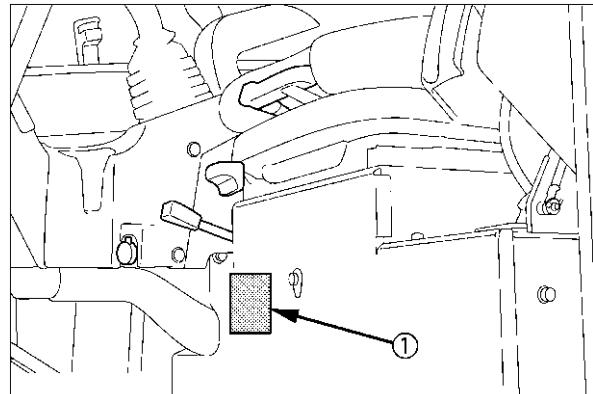
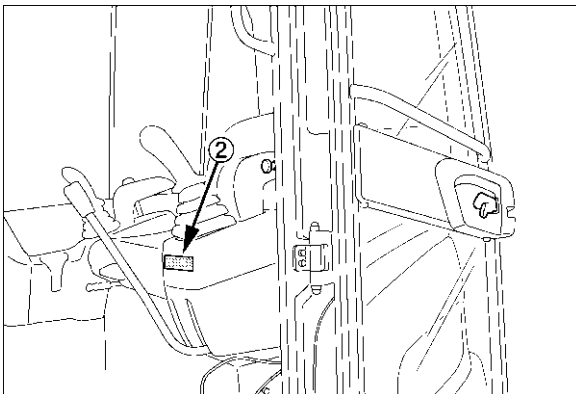
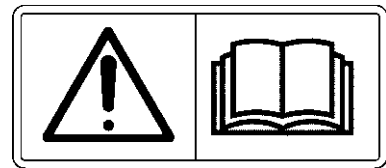

Safety rules

1) Code #: RG158-5732-0

Risk of burns from hot components!

Surfaces can be hot and lead to burns.

- Apertures, e.g., ventilation systems, and hot components, must not be covered with hands.

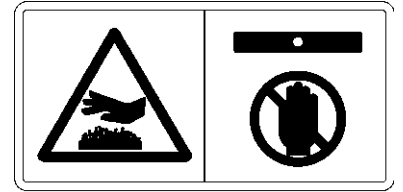

2) Code #: RG138-5717-0

When using a wider or deeper bucket, take good care when swinging or retracting the front attachments to make sure that the bucket does not hit the cab.

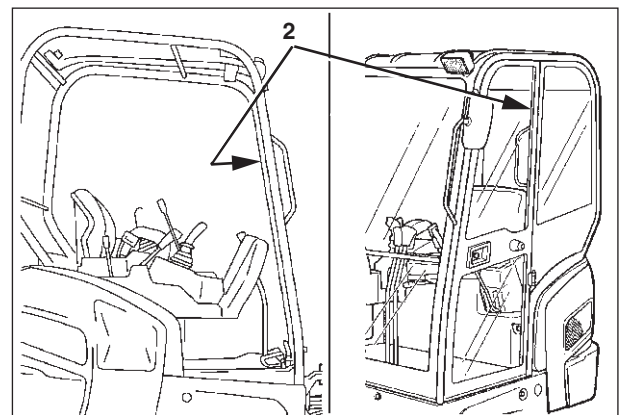
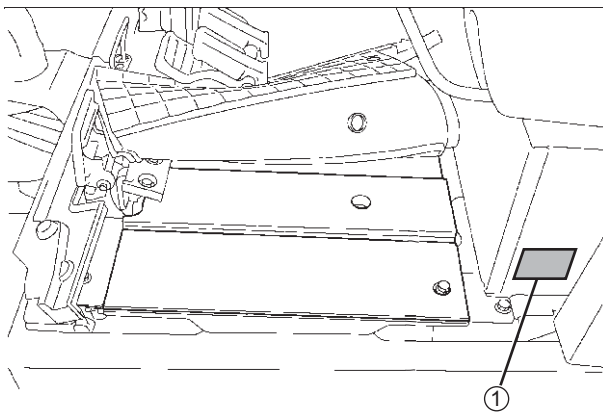
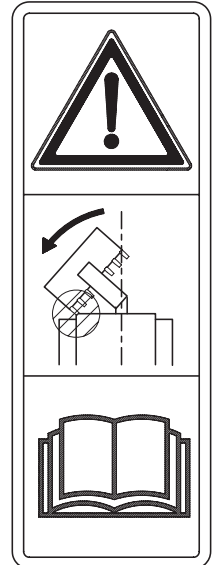

1) Code #: RG158-5734-0

Risk of injury when entering or leaving the machine!

When entering or leaving the machine without a secure halt, you can slip and fall down.

- Do not jump up or down the excavator.
- Always hold fast with one hand at the hand rail.
- Pay attention to a safe step.



2) Code #: RG158-5729-0

Risk of injury from falling front window!

If the front window has been pushed up and not is properly bolted, there is a risk that the front window will close automatically and hit the operator in the head.

- Always lock front window securely.



3) Code #: RG158-5749-0

Risk of accidents by exceeded load when lifting!

When exceeding the nominal load, a beep sounds and a warning light illuminates.

- Turn on overload warning function before starting a lifting operation!

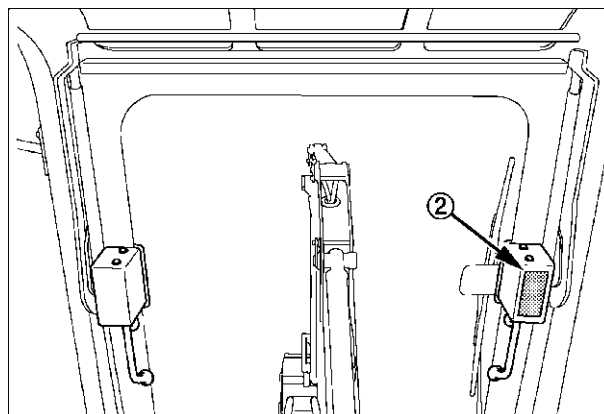
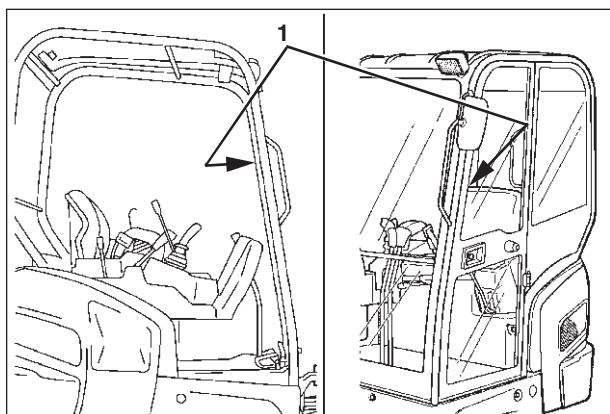

Safety rules

Safety devices

Before starting the excavator, all safety devices must be installed properly and operational. No manipulation of safety devices, e.g. the shorting of limit switches, is allowed.

Protective devices may only be removed after

- the excavator is standing still and the engine is stopped
- and secured against restarting (starter switch in STOP position and key removed).

Locking the controls

The control levers (3 and 6) on the right and left, the drive levers (2), the boom swing pedal (1), and the dozer control lever (5) are not operational when the console (7) is raised. This circumstance allows safe getting on and off. The console is unlocked and raised with the control lever lock (4).



Engine stop knob

The engine is turned off when the starter switch (2) is switched in position STOP.

If the engine cannot be turned off, please operate the engine stop knob switch in order to turn off the engine.

To stop the engine:

- Pull the knob (1) until the engine stops.
- After the engine has stopped, push in the knob.

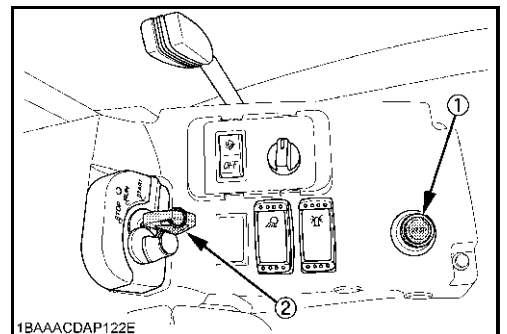

Protective structure canopy and cab



The excavator is equipped with a protective structure that protects the operator from severe injury or death if the excavator falls over or overturns and in the case of falling objects.

Canopy and cab were constructed in accordance with current safety standards and tested for verification as:

Roll-over protection	ROPS (Roll Over Protective Structure)
Tipping-over protective structure	TOPS (Tipping Over Protective Structure)
Canopy	OPG (Operator's Protective Guard)

To ensure greatest protection by means of this protective structure, the following applies:

- The seat belt must be fastened while the excavator is being operated.
- There must be no structural changes to the canopy or roll-over protection.
- In the event of damage, please contact your KUBOTA dealer. (Do not repair!)
- Never operate the excavator without canopy or roll-over protection.

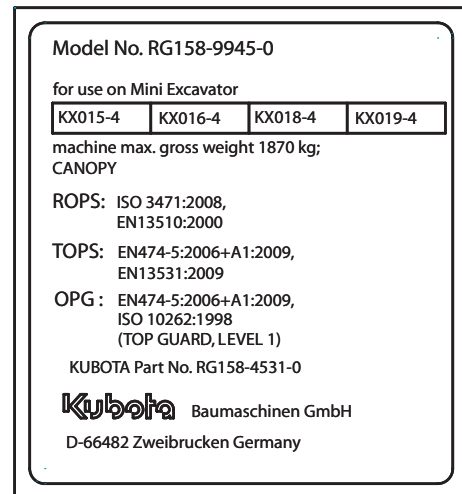

Use utmost care to avoid any risk of tipping, slipping, or other potential risks implied when lifting loads. The operator must

- drive at reduced vehicle speed,
- avoid sudden braking,
- avoid sudden steering movements,
- secure any logs and/or rods at their centre of weight,
- make sure the load does not swing when travelling,
- check for a potential need of a gravel guard or a canopy.

With the use of a hydraulic hammer or another attachment for demolition work, where material is removed and can uncontrollably sputter away, as well as for any lifting work, a gravel guard is recommended (page 161) for protection.

Safety rules

Emergency hammer

In case of an accident where the excavator cab door and windows can not be opened, the operator can break the window panes with the emergency hammer (1).



When breaking the window pane, close your eyes and cover them with an arm.

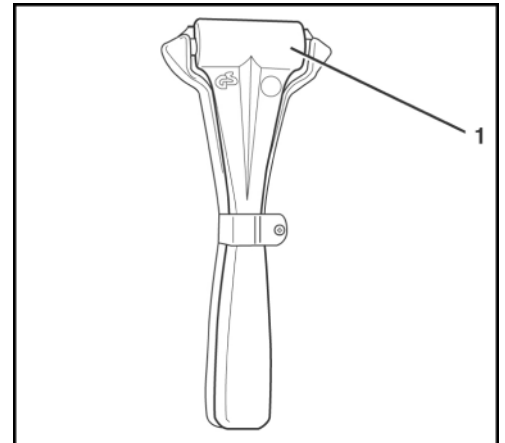

Locking of the swivel frame

The swivel frame lock (1) serves for securing the swivel frame against unintentional rotations, e.g. during transport.

If the swivel frame lock is in unlocked position (A), rotating of the swivel frame is possible.

For locking, the swivel frame lock must be brought into position (B).



Before locking the swivel frame, swivel frame and track frame must be aligned parallel to each other.

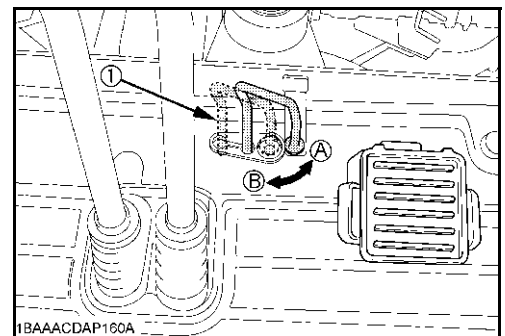

Hazards coming from the hydraulic system

If hydraulic oil gets into the eyes, rinse them immediately with clear water and subsequently seek medical aid.

Do not allow hydraulic oil to contact the skin or clothing. Skin parts which may have come in contact with hydraulic oil must be washed with water and soap immediately, if possible. Do this thoroughly and repeatedly, otherwise there is a risk of damage to the skin.

Immediately take off any clothes dirtied or soaked with hydraulic oil.

Persons who have inhaled hydraulic oil vapours (mist) should be taken to a doctor immediately.

If leaks have occurred in the hydraulic system, the excavator may not be taken into operation or, if in operation, operation must cease at once.

Do not use the naked hand to search for leaks; always use a piece of wood or cardboard. Protective clothing (eye protection and gloves) must be worn when seeking leaks.

Leaking hydraulic oil must be bound immediately with an oil binding agent. The contaminated oil binding agent must be stored in suitable containers and in accordance with the valid regulations.

Fire protection



The excavator components and attachments (in particular the engine and the exhaust system) reach high temperatures even at normal working conditions. An electric installation which is damaged or not properly serviced may lead to flashovers and/or electric arcs. The following Fire Protection Guidelines may help you ensure the maintenance and efficiency of your equipment and minimize fire hazards.

- Remove any accumulated dirt adjacent to hot components, e.g. engine, muffler, exhaust manifold/tubes, etc. If the machine is being used to full capacity, the cleaning procedure should be performed more frequently.
- Accumulated residues from plants and trees, or any other flammable materials, should be removed from the machine. This must be observed in particular in the proximity of the engine and the exhaust system, but also at the swivel frame, the track frame, and the boom.
- Check the condition and wear of all fuel lines and hydraulic hoses. Any defective parts should be replaced immediately in order to avoid leakage.
- Electric lines and connections must be checked regularly for signs of damage. Damaged components and lines must be replaced or repaired before starting up the machine. All electric connections must be kept clean and solid.
- Exhaust pipes and mufflers must be checked daily for leaks, damage and any loose or missing joints. Leaking or damaged exhaust system components must be replaced or repaired before starting up the machine.
- Always keep a multipurpose fire extinguisher at or close to the machine. Make yourself familiar with the operation of the fire extinguisher. In the event of fire in the electrical or hydraulic system, use a CO₂ fire extinguisher to combat the fire.
- For attaching a fire extinguisher (1) two threads (2) have been inserted in the cab construction on the left side behind the driver's seat.



A fire extinguisher is not included in the basic equipment of the machine.

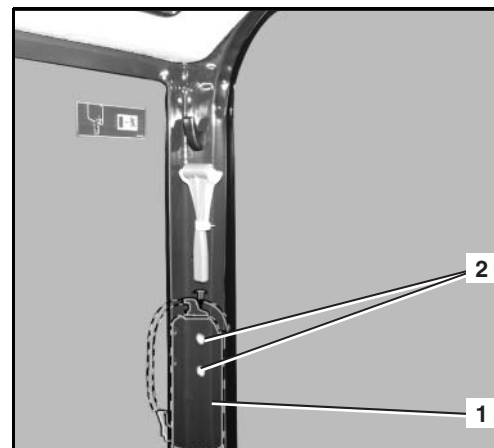

Recovery, loading and transport

Safety rules for recovery

- For recovery of the excavator, a towing vehicle of at least the same weight class as the excavator must be used.
- A tow bar must be used for the recovery. If a tow rope is used, an additional vehicle to brake the excavator must also be attached. The tow bar or tow rope must be suitable for the recovery of the excavator in respect of the towed load. Do not use damaged recovery aids.
- Do not step into the danger zone between the vehicles during the recovery procedure. If a tow rope is used, keep a distance of at least 1.5 times the length of the rope.
- Use the towing eye on the track frame for the recovery.
- The above safety rules also apply if the excavator is used as the towing or recovery vehicle.
- Observe the admissible values for the towed load and the maximum pressing load vertical down on the towing eye during recovery, see "Specifications (page 39).

Safety rules while loading with a crane

- Crane and lifting gear must be suited for the absorption of the load to be lifted and be approved.
- Before the use of the crane and the lifting gear, make sure that the specified safety inspections at regular intervals have been carried out and that the crane and lifting gear are in good working order and impeccable condition.
- The excavator may only be lifted at the points provided. Do not attach the lifting gear to the cab roof as this can lead to substantial damage.
- Never attach a crane hook to the lower edge of the dozer! The crane hook can slip off sideways while lifting and the excavator may fall off.
- Always adhere to the valid safety regulations for the lifting of loads.
- The excavator must be secured with a holding rope when it is being lifted.
- The crane operator is responsible for the observance of these safety rules.

Safety rules for transport

- The ramps must have a sufficient load capacity for bearing the weight of the excavator. They must be placed securely on the transport vehicle and fastened.
- Support the loading area at the rear of the transport vehicle with sufficiently dimensioned supports.
- The ramps must be wider than the track of the excavator and have footboards on the side.
- The transport vehicle must be designed for the load of the excavator.
- Place the left and the right ramp so that the centre line of the transport vehicle is aligned with the centre line of the excavator to be loaded.
- Do not drive the excavator onto the transport vehicle without ramps and with the boom.
- In the transport vehicle, pull the parking brake and secure the individual wheels of the transport vehicle at the front and rear, respectively, with chocks.
- Secure the excavator against sliding on the transport vehicle with chocks or chains or with suitable tiedown straps. The chocks must be secured at the crawlers and on the transport vehicle with suitable means. The operator of the transport vehicle is responsible for the secure fastening of the excavator on the vehicle.
- A guide is required for driving the excavator onto and off the transport vehicle. The guide is responsible for the safe loading. The excavator may only be moved on instruction of the guide; the operator and guide must always have eye contact. If this is not possible, the operator must stop the excavator immediately.
- When driving with an excavator loaded, always keep a clearance of 1.0 m to overhead power lines. Observe the applicable traffic rules and regulations.

Recovery



Adhere to the safety rules (page 13) and the safety rules for recovery (page 29).



A recovery is only allowed over a short distance and at walking speed (0.5 m/s ~ 1.0 m/s).

- Attach the tow bar or tow rope to the attachment point (1) on the excavator and to the towing vehicle.

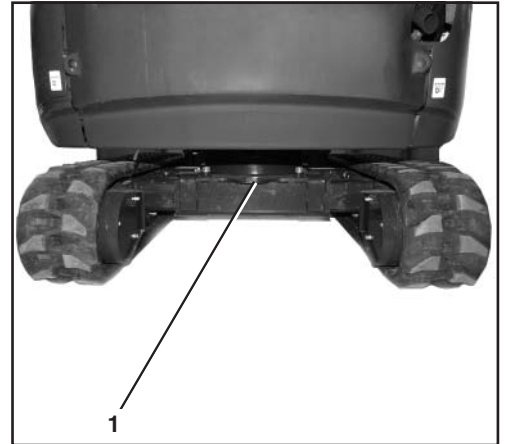

- If the attachment point of the excavator is not accessible, a tow rope can also be fastened around the centre of the dozer.
- During the recovery procedure, the operator must be seated on the operator's place.
- Drive slowly with the towing vehicle to avoid abrupt loads.

Hoisting the excavator with a crane



Adhere to the safety rules (page 13) and the safety rules for hoisting the excavator with a crane (page 29).

- Bring the excavator to the lifting position (see figure) on level ground.
- Lift the dozer until the dozer cylinders are fully retracted. Also see the "Operating the controls during excavation work" section) (page 77).

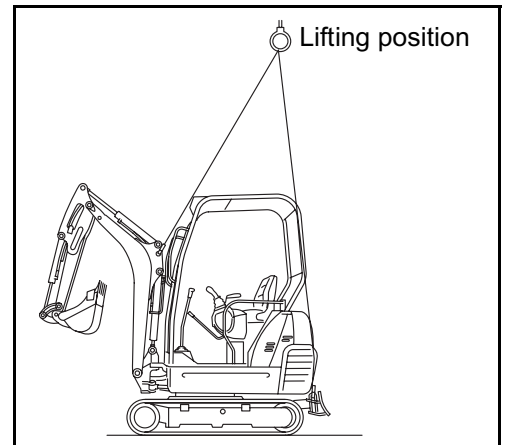

- Bring the boom in line with the longitudinal axis of the swivel frame.
- Bucket cylinders and arm cylinders, respectively, must be extended up to the stop position.
- Boom cylinders must be extended up to the stop position.
- Swivel the swivel frame so that the dozer is located at the rear.
- Close and lock the door and covers.



The excavator may only be lifted at the points provided. Do not attach the lifting gear to any other eyes or areas as this can lead to substantial damage.

- Attach the lifting gear with shackles to the lifting eyes (1) on each side of the dozer.

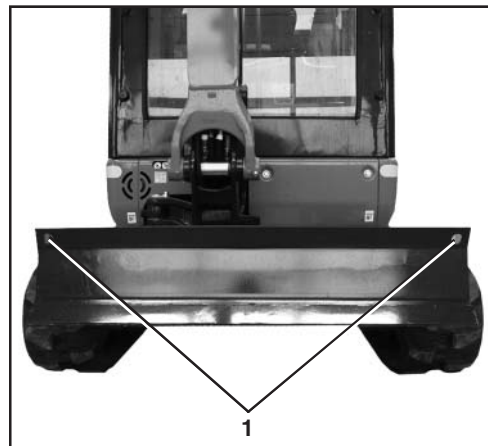

- Attach the lifting gear with shackles to the lifting eyes (1) on each side of the boom.



- As soon as the lifting gear is attached to the excavator, press cloths between lifting gear and excavator to protect the excavator.
- Always keep the machine level. Be sure that the centre line of the crane hook is aligned as exactly as possible with the centre line of the excavator and that the lifting angle is as specified. Lift the excavator.

Recovery, loading and transport

Transport on a flat bed trailer



Adhere to the safety rules (page 13) and the safety rules for transport (page 30).

- Place the loading ramps on the transport vehicle at an angle of 10° to 15°. Observe the track width. Safely attach the ramps to the transport vehicle to make sure they cannot slide while driving upwards.

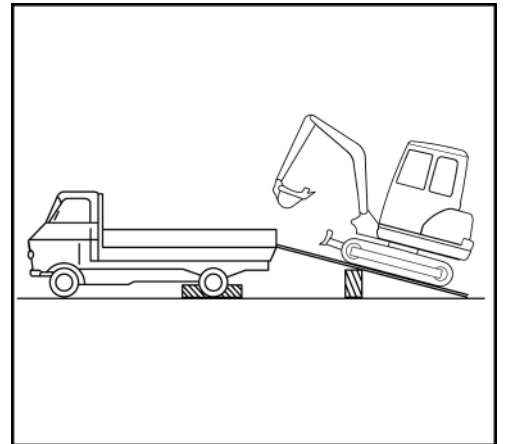

Do not turn or steer while driving up the ramps; if necessary, reverse the excavator and drive up again after realigning it.

- Bring the excavator exactly into line with the ramps and drive up straight. Lower the dozer onto the loading area.



*Caution! Danger!
No person is allowed to stand on the loading area during swivelling. Risk of bruising.*



Take care during swivel operations. The front attachments could hit the transport vehicle. This could damage the transport vehicle and the excavator.

- Turn swivel frame by 180° until the front attachments face the rear of the transport vehicle.

For securing the vehicle, tie down the points as shown in the figure. The corresponding eye bolts must be screwed in at the rear weight (2 pieces, not included in the scope of delivery).



- For safe attachment, fully crowd the arm and bucket and lower the boom until the bucket linkage touches the loading area.
 - Secure the chains and the dozer with beams (2).
 - Secure the excavator against sliding on the transport vehicle with chocks or chains (1) (note the vehicle weight).
-
- Lock the excavator after hoisting.

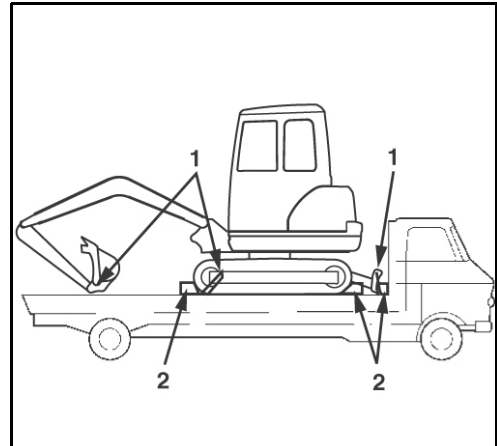

Description of the excavator

Description of the excavator

Model overview

The excavator is available in the model series KX015-4, KX016-4, KX018-4 and KX019-4 .

The figures show the versions with canopy and cab.



Dimensions

The dimensions of the models KX015-4, KX016-4, KX018-4 and KX019-4 can be found in the following illustrations including tables.

Dimensions KX015-4

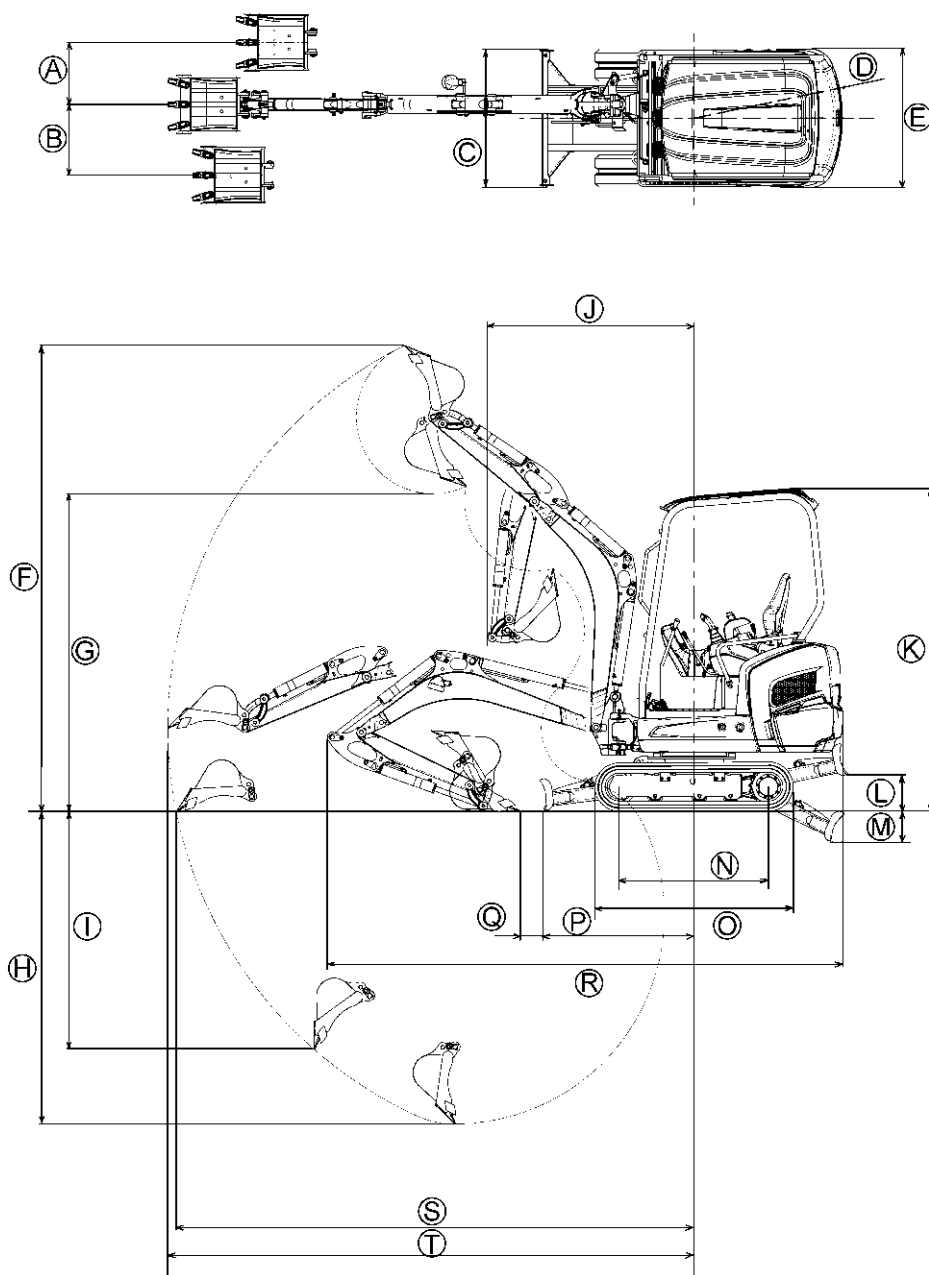

1BAAACDAP199A

All dimensions in mm with original KUBOTA bucket and rubber crawlers

	A	B	C	D	E	F	G	H	I	J	K	L
KX015-4	450	510	990	1070	990	3360	2290	2250	1810	1490	2330	240
	M	N	O	P	Q	R	S	T				
KX015-4	230	1090	1450	1090	160	3710	3730	3790				

Description of the excavator

Dimensions KX016-4, KX018-4 and KX019-4

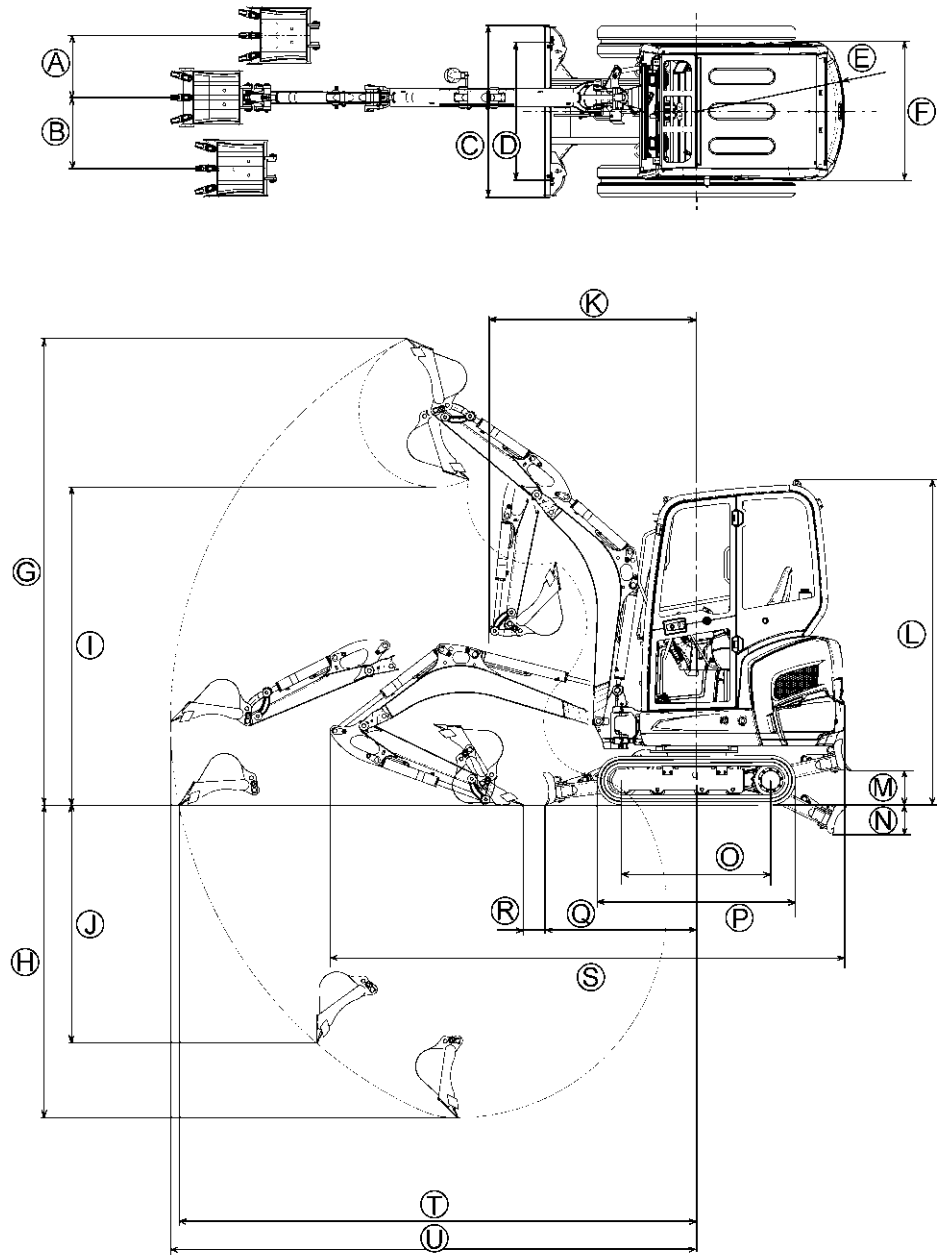



1BAAACDAP200A

All dimensions in mm with original KUBOTA bucket and rubber crawlers

	A	B	C	D	E	F	G	H	I	J	K	L
KX016-4	450	510	1240	990	1070	990	3360	2250	2290	1810	1490	2350
KX018-4	450	510	1300	990	1070	990	3450	2380	2380	1940	1480	2350
KX019-4 SF	450	510	1300	990	1100	990	3450	2380	2380	1940	1480	2350
KX019-4	450	510	1300	990	1100	990	3620	2580	2560	2140	1520	2350
	M	N	O	P	Q	R	S	T	U			
KX016-4	240	230	1090	1450	1090	160	3710	3730	3790			
KX018-4	230	230	1230	1590	1080	60	3710	3860	3920			
KX019-4 SF	230	230	1230	1590	1080	60	3740	3860	3920			
KX019-4	230	230	1230	1590	1080	100	3860	4070	4120			

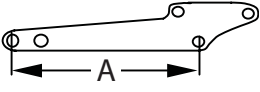
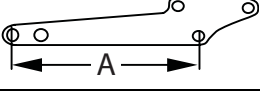
Arm version

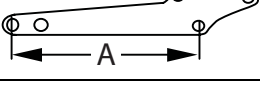
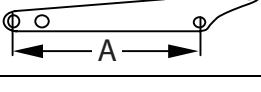
Name		Type	
KX015-4	Arm 950 mm		A = 950 mm
KX016-4	Arm 950 mm		A = 950 mm
KX018-4	Arm 1090 mm		A = 1090 mm
KX019-4 SF	Arm 1090 mm		A = 1090 mm
KX019-4	Arm 1190 mm		A = 1190 mm

Description of the excavator

Specifications

Following are the specifications for these series.

Specifications KX015-4/KX016-4

		KUBOTA Excavator		KUBOTA Excavator		
Model name		KX015-4		KX016-4		
Type (rubber crawler)		Canopy	Cab	Canopy	Cab	
Machine weight	kg	1420	1470	1490	1540	
Operating weight*	kg	1495	1545	1565	1615	
Bucket	Volume (CECE)	m ³		0.035		
	Width without side blade	mm		402		
	Width with side cutters attached	mm		422		
	Weight	kg		32.5		
Engine	Type	3-cylinder diesel engine, water-cooled		3-cylinder diesel engine, water-cooled		
	Model name	D782-BH		D782-BH		
	Displacement	cm ³		778		
	Engine performance (ISO 9249)	kW		9.6		
	Rated speed	1/min		2300		
Performance	Swivel speed	1/min		9.1		
	Vehicle speed	Travel speed	km/h		-	
		Low speed	km/h		2.1	
	Ground pressure (without operator)	kPa (kgf/cm ²)	24.5 (0.25)	25.5 (0.26)	25.5 (0.26)	26.5 (0.27)
	Climbing performance	% (degrees)	27 (15)		27 (15)	
	Max. lateral sway	% (degrees)	18 (10)		18 (10)	
Dozer (width x height)	mm	990 x 230		990/1240 x 230		
Swing angle of the boom	Left	degrees		75		
	Right	degrees		60		
Auxiliary port connector	Max. flow rate (theoretical)	L/min		27		
	Max. pressure	MPa (bar)		20.6 (210)		
Fuel tank capacity	L	21		21		
Pulling capacity at the towing eyes	N	32300		32300		
Vertical load at the towing eyes	N	2700		2700		
Noise level	LpA	dB (A)		76		
	LwA (2000/14/EC)	dB (A)		93		
Vibration at the drive levers**	m/s ²	< 2.5		< 2.5		
Vibration at the control levers**	m/s ²	< 2.5		< 2.5		
Vibration at the operator's seat**	m/s ²	< 0.5		< 0.5		
Vibration at the bottom plate**	m/s ²	< 0.6		< 0.6		
Vibration at the wrist rest**	m/s ²	< 2.5		< 2.5		

* With operator 75 kg, standard bucket 35 kg, operation readiness established

** These values are measured under specific conditions at maximum engine speed and can deviate, depending on the operating situation.

Specifications KX018-4/KX019-4

		KUBOTA Excavator		KUBOTA Excavator		
		KX018-4		KX019-4		
Model name						
Type (rubber crawler)		Canopy	Cab	Canopy	Cab	
Machine weight	kg	1620	1720	1680 1675***	1780 1775***	
Operating weight*	kg	1695	1795	1755 1750***	1855 1850***	
Bucket	Volume (CECE)	m ³		0.040		
	Width without side blade	mm		452		
	Width with side cutters attached	mm		472		
	Weight	kg		33.5		
Engine	Type	3-cylinder diesel engine, water-cooled		3-cylinder diesel engine, water-cooled		
	Model name	D902-BH		D902-BH		
	Displacement	cm ³		898		
	Engine performance (ISO 9249)	kW		11.8		
	Rated speed	1/min		2300		
Performance	Swivel speed	1/min		9.1		
	Vehicle speed	Travel speed	km/h		4.0	
		Low speed	km/h		2.2	
	Ground pressure (without operator)	kPa (kgf/cm ²)	25.5 (0.26)	26.5 (0.27)	26.5 (0.27)	27.4 (0.28)
			Climbing performance % (degrees)		27 (15)	
	Max. lateral sway		% (degrees)		18 (10)	
	Dozer (width x height)		mm		990/1300 x 230	
Swing angle of the boom	Left	degrees		75		
	Right	degrees		60		
Auxiliary port connector	Max. flow rate (theoretical)	L/min		27.7		
	Max. pressure	MPa (bar)		21.6 (220)		
Fuel tank capacity		L		21		
Pulling capacity at the towing eyes		N		32300		
Vertical load at the towing eyes		N		2700		
Noise level	LpA	dB (A)		77		
	LwA (2000/14/EC)	dB (A)		93		
Vibration at the drive levers**		m/s ²		< 2.5		
Vibration at the control levers**		m/s ²		< 2.5		
Vibration at the operator's seat**		m/s ²		< 0.5		
Vibration at the bottom plate**		m/s ²		< 0.7		
Vibration at the wrist rest**		m/s ²		< 2.5		

* With operator 75 kg, standard bucket 35 kg, operation readiness established

** These values are measured under specific conditions at maximum engine speed and can deviate, depending on the operating situation.

*** For version KX019-4 SF ("Short Front")

Description of the excavator

Identification of the excavator

The type plate of the excavator is located at the front of the swivel frame. The owner should enter the stamped data in the field on the back of the front cover.

1. CE marking
2. Serial #
3. Max. pulling capacity at the towing eyes
4. Max. vertical load at the towing eyes
5. Product ID number PIN
6. Year of construction
7. Engine performance
8. Operating weight
9. Model name
10. Manufacturer

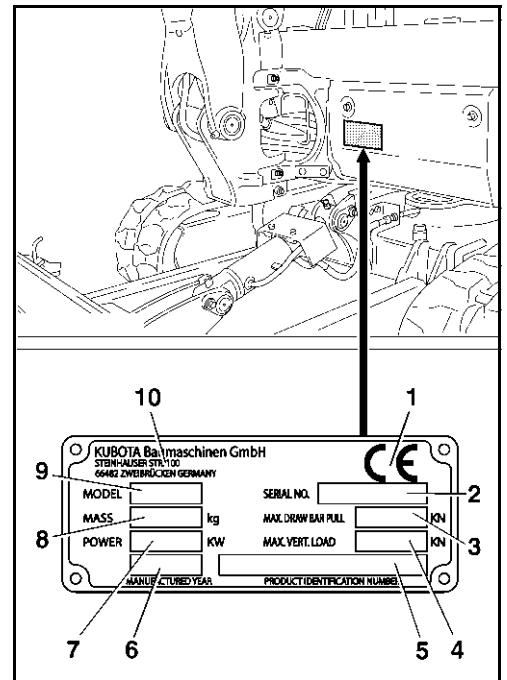

Serial # of the machine

The machine serial # (1) is stamped on at the track frame in the area of the swing bracket.



Engine number

The engine number (1) is stuck on the valve cover of the engine.

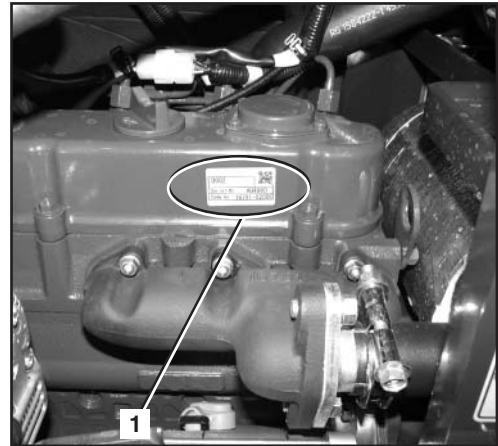

Equipment

The standard equipment of the excavator can be enhanced by optional equipment (accessories).

Standard equipment

This model has the following standard equipment:

- Operating instructions with protective cover
- Spare parts catalogue
- Filter wrench
- Filler funnel for diesel fuel
- Grease gun
- Spare fuse (50 A)
- Guarantee

Spare parts catalogue and guarantee can be kept together with the operating instructions (page 12).

The grease gun, the filter wrench and the filler funnel must be stowed away in the tool compartment (1) below the seat.

The cab version's filler funnel is located behind the operator's seat.

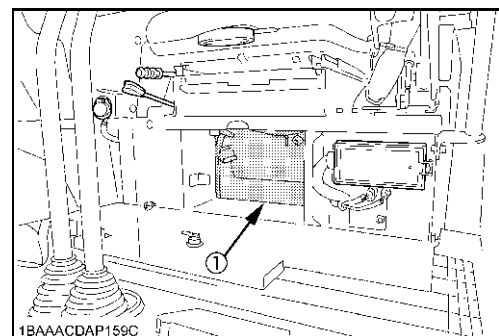

Assembly and functions

Component overview

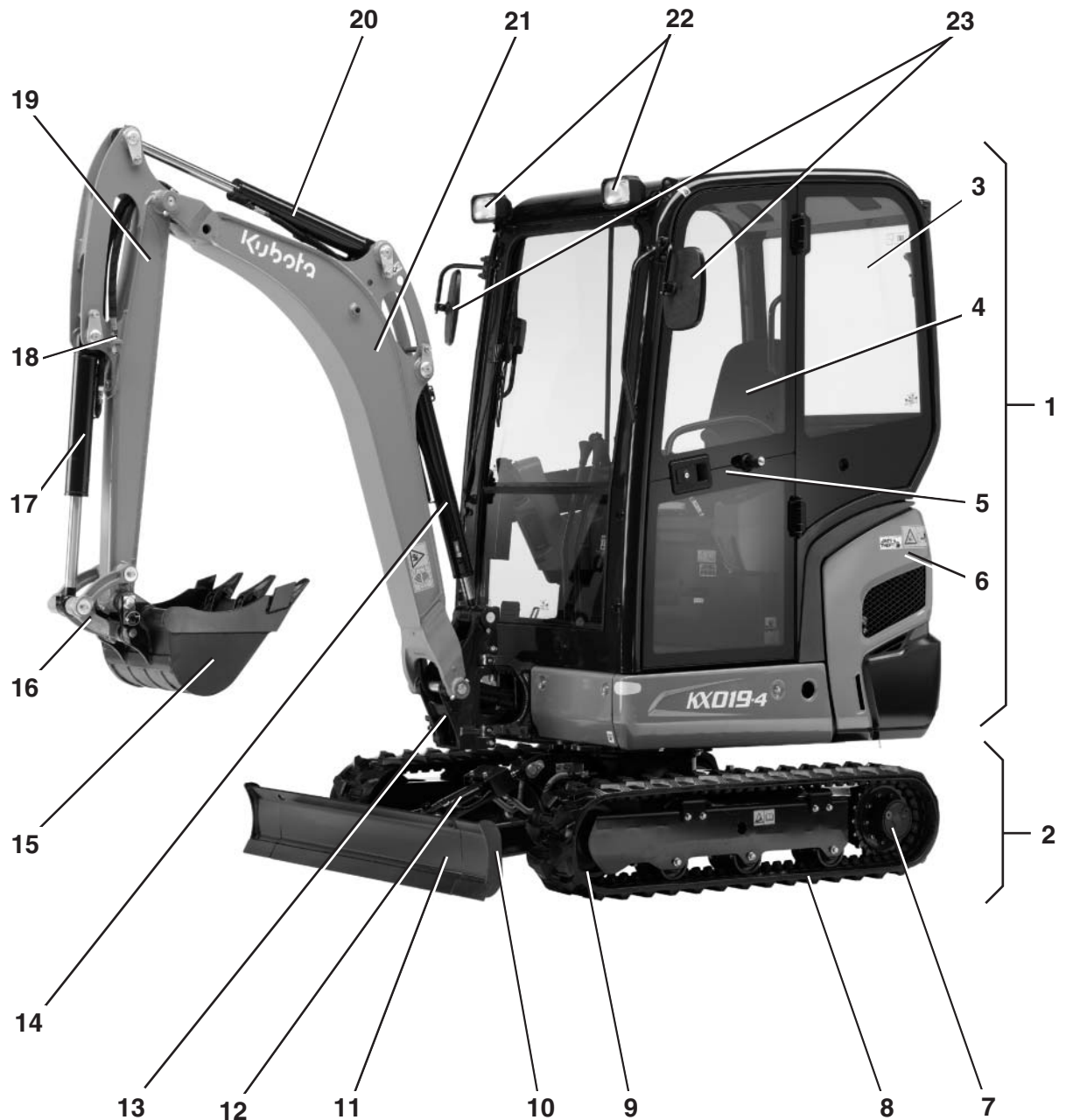

- | | |
|-----------------------|-------------------------------|
| 1. Swivel frame | 13. Swing block |
| 2. Track frame | 14. Boom cylinder |
| 3. Cab | 15. Bucket |
| 4. Operator's place | 16. Bucket linkage |
| 5. Cab door | 17. Bucket cylinder |
| 6. Side cover | 18. Auxiliary port connectors |
| 7. Drive sprocket | 19. Arm |
| 8. Crawler | 20. Arm cylinder |
| 9. Idler | 21. Boom |
| 10. Dozer enlargement | 22. Working lights (cab) |
| 11. Dozer | 23. Rear view mirror |
| 12. Dozer cylinder | |

Operator's place

The operator's place is located in the middle of the cab. It includes the following control elements:

1. Left control console
2. Drive levers and control pedals
3. Right control console
4. Operator's seat

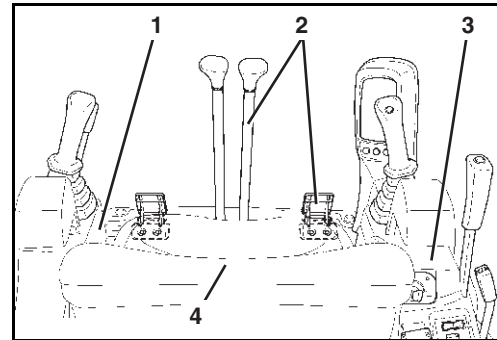

Left control console

The left control console includes the following components:

1. Control lever lock
2. Wrist rest
3. Left control lever

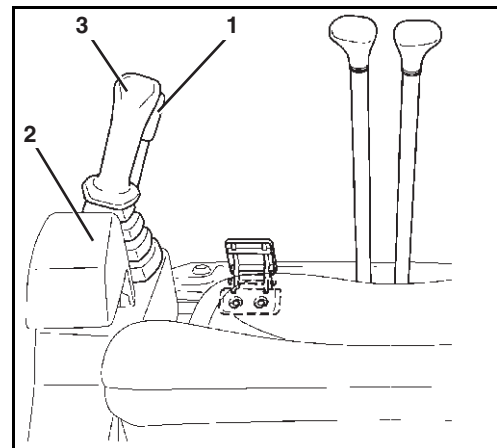

Description of the components of the left control console

1. Control lever lock

To enter and leave the cab, the console must be raised by pulling up the control lever lock. The engine can only be started if the console is raised. The control levers, the drive levers, the boom swing pedal, and the dozer control lever are only operational when the console is lowered and the control lever lock is in the "down" position.

2. Wrist rest

The wrist rest allows fatigue-free operation of the control lever.

Assembly and functions

3. Left control lever

The left control lever is used to move the swivel frame and the arm.

The figure, in conjunction with the following table, shows the functions of the left control lever.

Position of control lever	Movement
1	Arm crowd
2	Arm dump
3	Swivel frame to the left
4	Swivel frame to the right

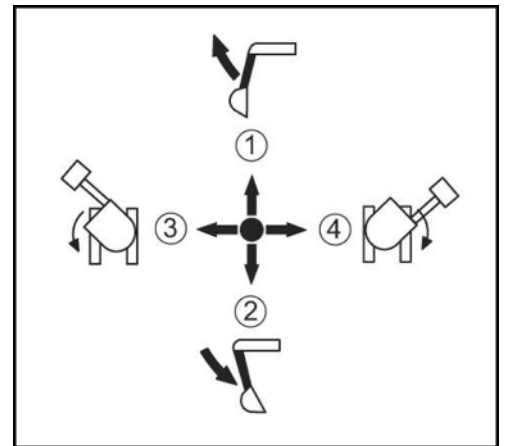

Drive levers and control pedals

Drive levers and control pedals include the following components:

1. Left and right drive levers
2. Boom swing pedal
3. Auxiliary port pedal (KX015-4/KX016-4/KX018-4)

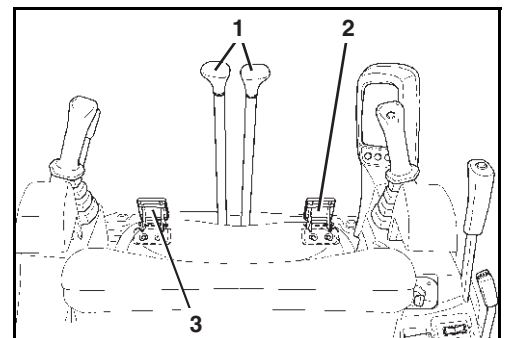

Drive levers and control pedals – description

1. Left and right drive levers

With the drive levers the excavator can be driven forwards and backwards and also turned. The left drive lever controls the left track and the right drive lever controls the right track.

2. Boom swing pedal

This pedal is used to swing the boom right and left.

3. Auxiliary port pedal (KX015-4/KX016-4/KX018-4)

The auxiliary port pedal can be used to operate an attachment.

Right control console

The right-hand control console contains the following components:

1. Rocker switch for the auxiliary port (KX019-4)
2. One way hold switch
3. Travel speed button (KX016-4/KX018-4/KX019-4)
4. Dozer control lever
5. Starter switch
6. Throttle lever
7. Wiper/washer switch (cab version)
8. Blower switch (cab version)
9. Engine stop knob
10. Rotary beacon button
11. Working light button
12. Wrist rest
13. Right control lever
14. Horn switch
15. Display and control unit

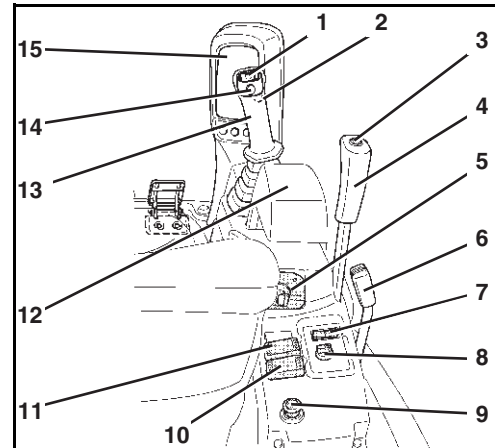

The display and control unit contains the following displays, switches, and indicators:

1. Fuel gauge
2. Charge indicator
3. Indicator Coolant temperature
4. Coolant temperature gauge
5. Display
6. Display selector switch
7. Menu button
8. Auxiliary port enable switch (KX019-4)
9. Warning light
10. Indicator Set clock
11. Indicator Servicing
12. Indicator Auxiliary port (KX019-4)
13. Indicator Pull out key
14. Indicator Insert key
15. Travel speed indicator
16. Indicator Fuel stock
17. Indicator Pre-glowing
18. Engine oil pressure indicator

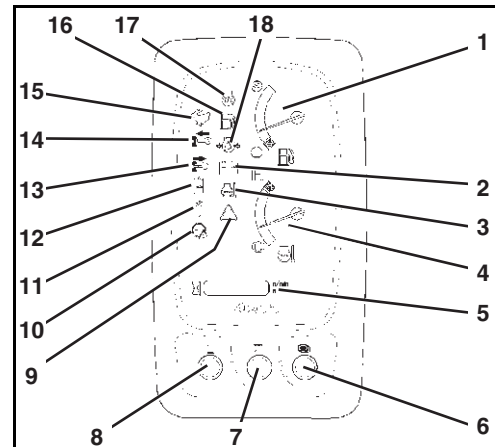

Description of the components of the right control console

1. Rocker switch for the auxiliary port (KX019-4)

The rocker switch for auxiliary port controls the oil flow to the auxiliary port. When the left rocker switch is activated the oil flows to the connector on the left of the arm. Activating the right rocker switch results in the oil flowing to the right. The auxiliary port can be controlled proportionally (stageless).

2. One way hold switch

Operating the one way hold switch results in a continuous oil flow to the auxiliary port connector to the left of the arm. When you operate it again, the oil flow discontinues. Thus, you can operate, for example, a breaker without having to continuously hold down the button.

3. Travel speed button (KX016-4/KX018-4/KX019-4)

The travel speed button switches the travel speed mode on and off.

Assembly and functions

4. Dozer control lever

The dozer control lever is used to raise or lower the dozer. Pushing the lever forward lowers the dozer and pulling it back raises it.

5. Starter switch

The starter switch serves as the master switch for the entire machine and as switch for pre-glowing and starting the engine.

6. Throttle lever

Using the throttle lever, the operator can adjust the engine speed in an infinitely variable manner.

7. Wiper/washer switch (cab version)

The wiper/washer switch switches on the wiper for the front window and/or the washer system.

8. Blower switch (cab version)

The fan is switched on with the blower switch. The air flow can be set to HIGH (HI) or LOW (LO).

9. Engine stop knob

Using this device, the operator can switch off the engine manually.

10. Rotary beacon button

The rotary beacon (accessory) is switched on with this button.

11. Working light button

Switches the working lights on or off.

12. Wrist rest

The wrist rest allows fatigue-free operation of the control lever.

13. Right control lever

The right control lever is used to move the boom and the bucket.

The figure, in conjunction with the following table, shows the functions of the right control lever.

Position of control lever	Movement
1	Lower boom
2	Raise boom
3	Bucket crowd
4	Bucket dump

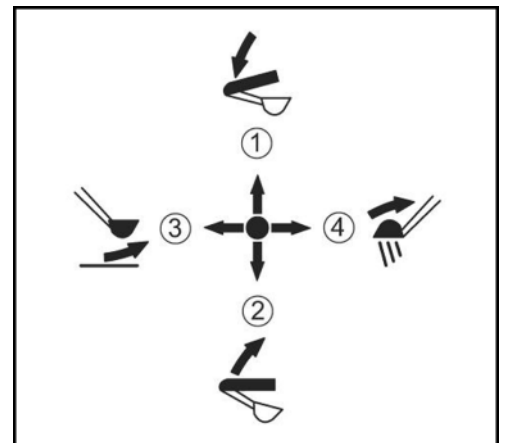

14. Horn switch

Depressing the horn switch activates the horn.

15. Display and control unit

The functions of the display and control unit are described in the "Display and control unit - description" section (page 48).

Display and control unit - description



The display and control unit's switches are multifunctional and are also used to navigate the display menu. You will find detailed descriptions of the individual functions in the respective chapters.

- 1. Fuel gauge**
The fuel gauge indicates the relative fuel amount in the tank.
- 2. Charge indicator**
The charge indicator lights up when the charging circuit voltage is too low.
- 3. Indicator Coolant temperature**
The indicator Coolant temperature lights up if there is elevated temperature in the cooling circuit.
- 4. Coolant temperature gauge**
The coolant temperature gauge indicates the temperature in the cooling circuit of the engine.
- 5. Display**
The display can indicate time, engine speed hours of operation and coding system information.
- 6. Display selector switch**
The display selector switch changes what is shown in the display.
- 7. Menu button**
The menu button is used to switch on or off the menu guide in the display.
- 8. Auxiliary port enable switch (KX019-4)**
The auxiliary port enable switch is used to switch on or off the auxiliary port function.
- 9. Warning light**
The warning light flashes red when a system fault or technical malfunction occurs. The warning light flashes yellow when the system issues a warning.
- 10. Indicator Set clock**
If the clock needs adjustment (e.g. after disconnecting the battery for servicing purposes), the indicator Set clock will flash.
- 11. Indicator Servicing**
The indicator Servicing shines when a service period is due.
- 12. Indicator Auxiliary port (KX019-4)**
The indicator Auxiliary port blinks if the auxiliary port function is switched on.
- 13. Indicator Pull out key**
The indicator Pull out Key shines if the ignition key is to be pulled out.
- 14. Indicator Insert key**
The indicator Insert key shines if the ignition key is to be inserted.
- 15. Travel speed indicator**
The travel speed indicator lights up when the travel speed mode is activated.
- 16. Indicator Fuel stock**
The indicator Fuel stock shines in the case of low fuel and requests refuelling

Assembly and functions

17. Indicator Pre-glowing

The indicator Pre-glowing shines with the switching of the starter switch in position RUN. When the indicator goes off, it is possible to start the engine.

18. Engine oil pressure indicator

The engine oil pressure indicator lights up when the oil pressure is below the reference value.

Other equipment at the operator's place

Other equipment located at and around the operator's place is described below.

Interior lighting

An interior light (1) is located on the left side of the cab roof. It is turned on and off with the switch (2).

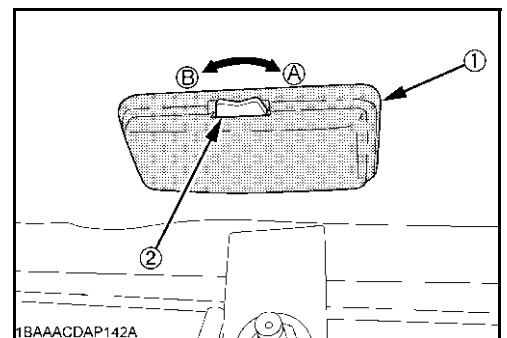

Fuse box

The fuse box (1) is located below the operator's seat behind a cover.

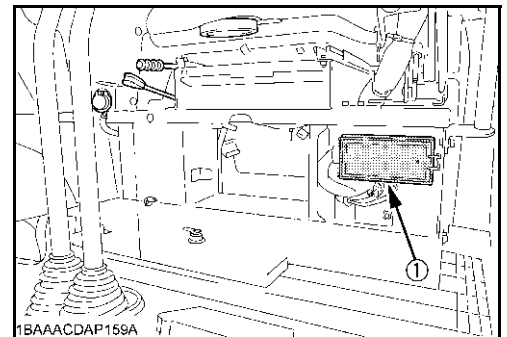

Tool compartment

The tool compartment (1) is located below the operator's seat behind a cover plate.

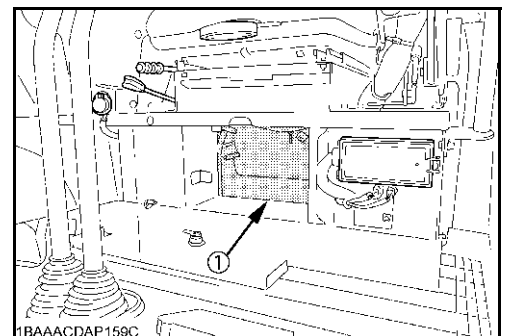

Cup holder

There is a cup holder (1) in the right control console.

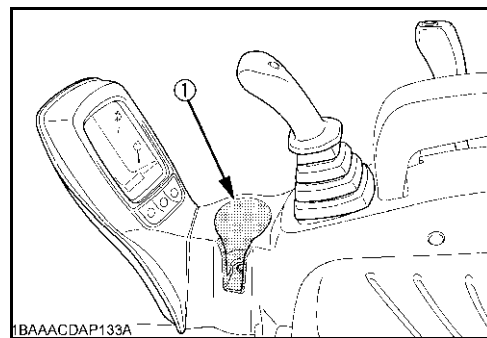

Funnel for diesel fuel

For safe filling of diesel fuel, the excavator is equipped with a filler funnel (1).

The storage location for the filler funnel is in the toolbox under the operator's seat.

The cab version's filler funnel is located behind the operator's seat.

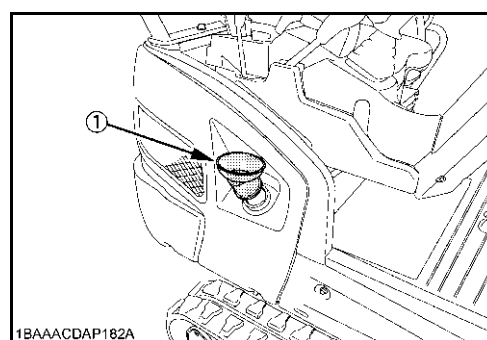

Extendable track width (KX016-4/KX018-4/KX019-4)

If the excavator is equipped with an extendable track width function, the track width of the excavator can be adjusted between standard track width (A) and narrow track width (B) for passing through narrow areas.

The track widths are:

- Standard track width (A): 1240 mm (KX016-4) resp. 1300 mm (KX018-4/KX019-4)
- Narrow track width (B): 990 mm

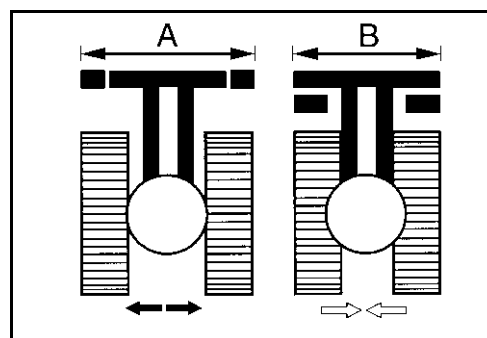

The setting of the track width is with the control lever for extendable track width (1).

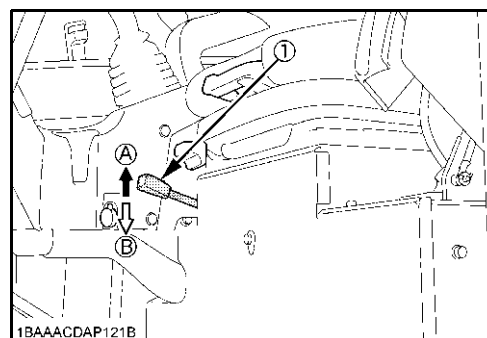

Caution - risk of tipping!

When carrying out excavating work using narrow track width, the excavator will become more unstable. The narrow track width should be used only for passing through narrow areas.

- As a general rule, perform any excavator work using standard track width (A).
- The excavator may not be operated with the narrow track width (B).

Other equipment to be found at the machine

Other equipment located at and around the machine is described below.

Main battery

The vehicle battery (1) is on the left vehicle side under the side cover.

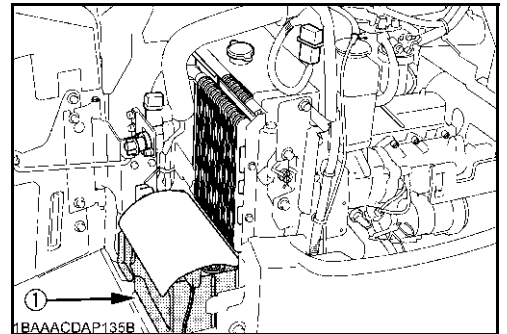

Battery cut-off switch

The battery cut-off switch (1) can be used to cut off the main power circuit. The battery cut-off switch is on the left vehicle side under the side cover.

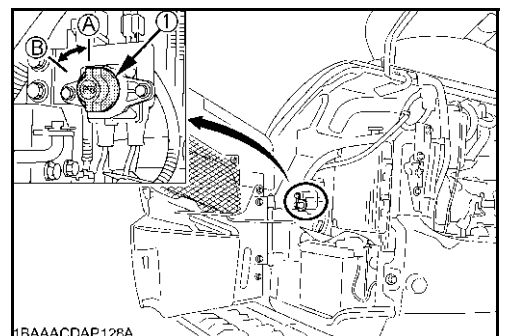

Return change valve for direct return flow

According to mode of operation of a given attachment, the return flow of the hydraulic oil must either be via the control valve (indirect return flow) or directly to the hydraulic oil tank (direct return flow).

With the change valve direct return flow (3), you undertake the setting between "indirect return flow" and "direct return flow".

The change valve direct return flow (3) is in the leg room below the leg room cover (1) directly at the hydraulic oil container (2).

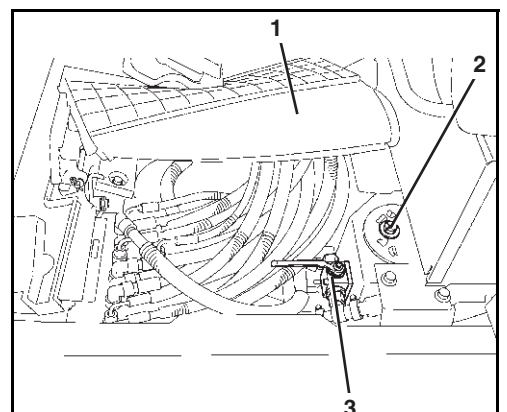

Tank filler neck and fill level monitor

The tank filler neck (1) is on the right side on the rear and is sealed with a lockable filler cap (2).

The fill level monitor (3) is located above of the tank filler neck and it indicates the fuel level when refuelling.

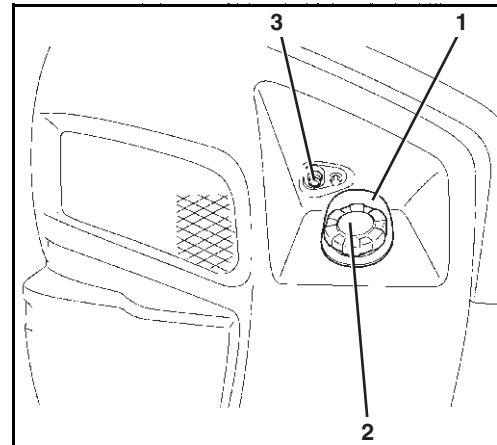

Rear view mirror

The rear view mirrors (1) allow for visibility to the rear. The rear view mirrors can be adjusted for optimum visibility of the respective areas.

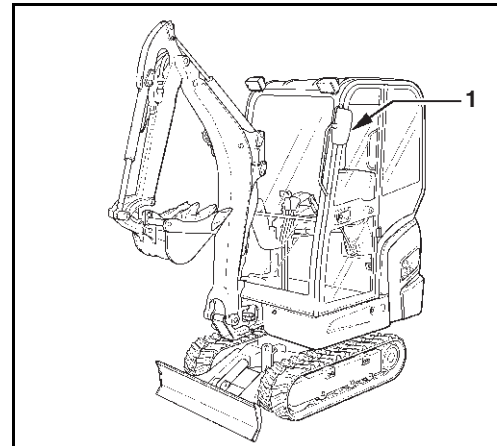

Heating and ventilation (cab version)

Turning on and switching off of the heater fan and the air volume control is via the blower switch (1) on the right control console.

Using the blower switch, air volume can be adjusted at two levels LO and HI, where level HI stands for max. blower output.

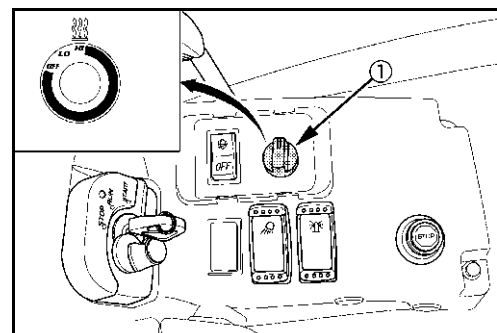

Assembly and functions

Air intake is as fresh air at the cab back wall or as circulating air in the cab.

With the lever (1) the air intake can be switched between recirculated air (A) and fresh air (B).

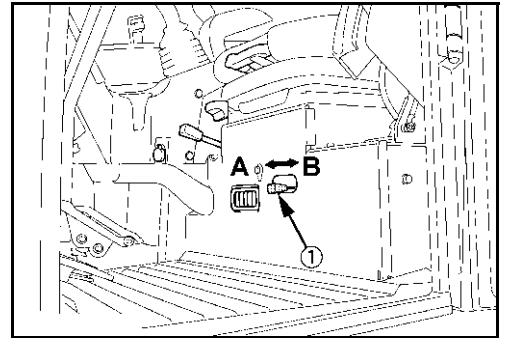

The air is guided to the air nozzles (1) via the heat exchanger.

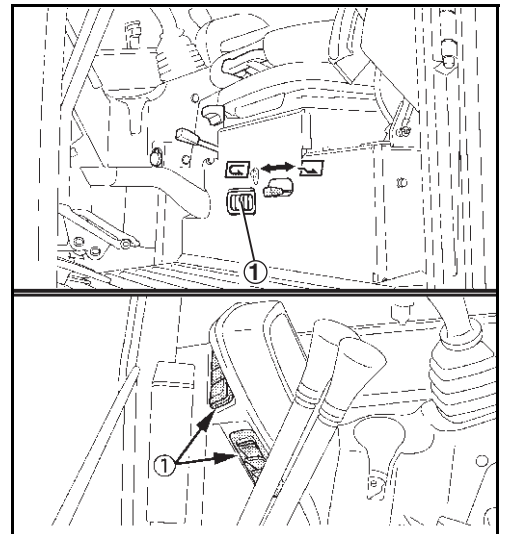

The heater valve (1) in the engine compartment regulates the supply of the heat exchanger with hot water from the cooling cycle.

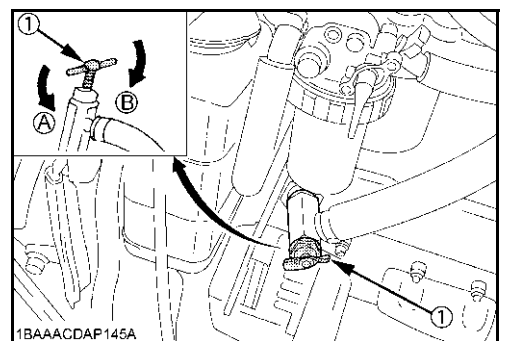

Engine compartment

The engine compartment (figure below) is positioned at the rear of the swivel frame; it is covered by a lockable hinged cover.

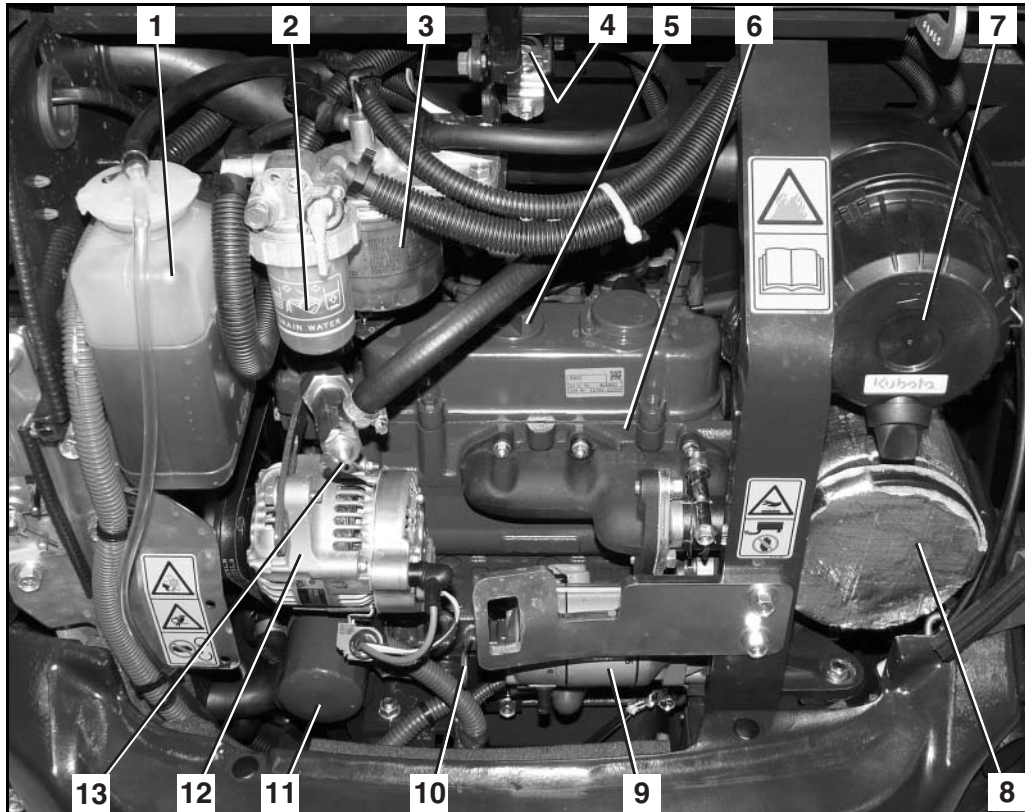

- | | |
|--------------------------------|--------------------------------|
| 1. Coolant expansion reservoir | 8. Muffler |
| 2. Water separator | 9. Starter |
| 3. Fuel filter | 10. Oil dipstick |
| 4. Fuel pump | 11. Engine oil filter |
| 5. Oil filler opening | 12. Alternator |
| 6. Engine | 13. Heater valve (cab version) |
| 7. Air filter | |

Hydraulic system

The controls, except the dozer control lever, the boom swing pedal, the auxiliary port pedal and the drive levers, activate hydraulic oil pilot circuit.

The dozer control lever controls the valve via a bowden cable.

The accumulator (figure below/ 4) allows lowering the boom and the arm in the event of engine failure.

The hydraulic oil tank contains the suction filter and the return filter.

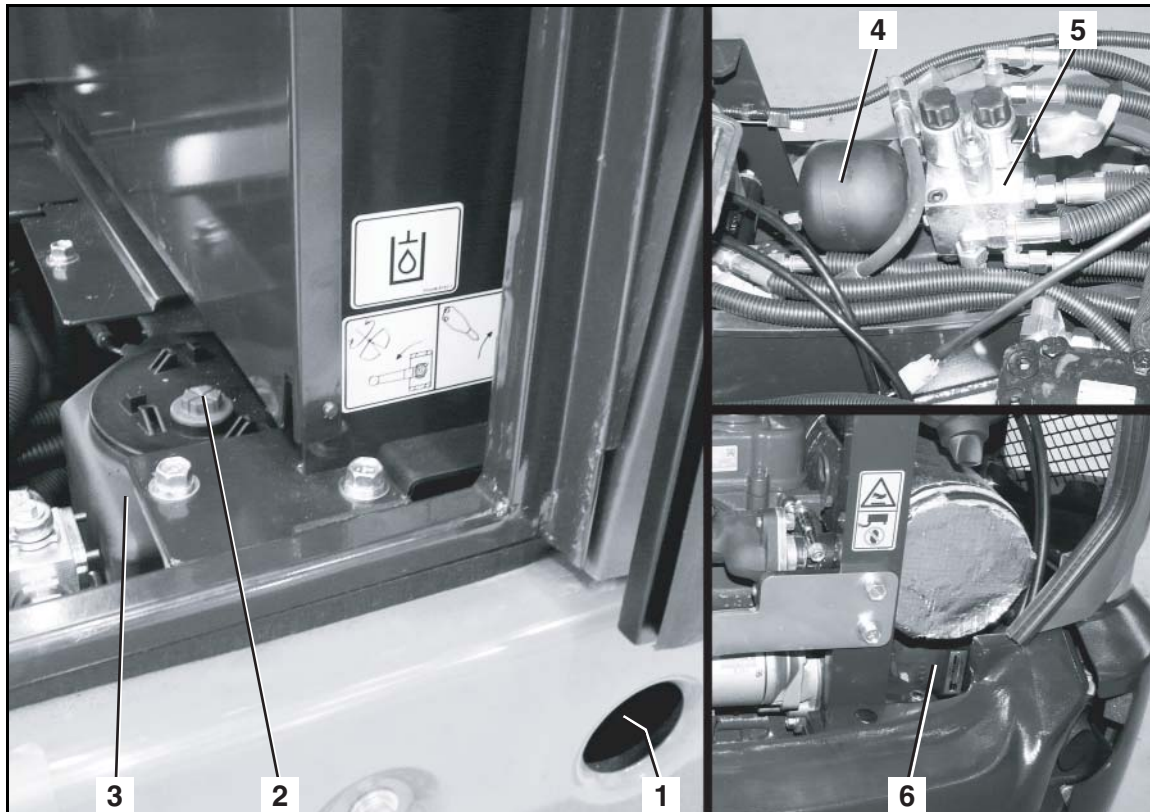

1. Sight glass for hydraulic oil level
2. Oil fill opening for hydraulic oil
3. Hydraulic oil tank

4. Accumulator
5. Control valve
6. Hydraulic oil pump

Coolant radiator and oil cooler

The coolant radiator and the oil cooler are located under the side cover.

1. Coolant radiator
2. Oil cooler
3. Tank breather filter



Do not unscrew the tank breather filter plug (4). The tank breather filter is not serviceable.

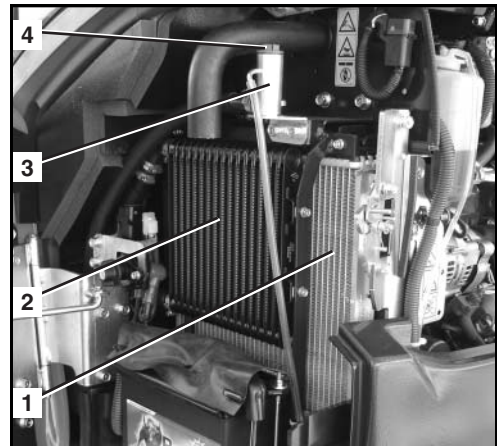

Operation

Safety rules for operation

- The safety instructions (page 13) must be followed.
- The excavator may only be operated according to its approved use (page 15).
- The excavator may only be operated by trained personnel (page 12).
- Do not operate the excavator when under the influence of drugs, medication or alcohol. Stop operation when getting tired. The operator must be physically capable of operating the excavator safely.
- The excavator should only be operated if all protective devices are fully operational.
- Before starting or working with the excavator, make sure that there is no danger for any person nearby.
- Before starting the excavator, it must be checked for external damage and operability, and the pre-start checks must be carried out. If defects are detected, the excavator should only be taken into operation after the defects have been repaired.
- Wear tightly fitting working clothes in accordance with the trade association regulations.
- During the operation of the excavator, nobody except the operator is allowed to be inside the cab or get on the excavator.
- For getting on and off, the swivel frame should be positioned in an angle which allows the operator to use the crawler or the step (if applicable) to enter the cab.
- Always stop the engine when leaving the cab. In exceptional cases, e.g. for troubleshooting, the cab can also be left with the engine running. The operator must make sure that the left control console remains in an upright position. The controls may only be used while the operator is sitting on the operator's seat.
- During operation, it is forbidden to stretch any part of the body out of the window or cab door, such as arms, legs, or the body.
- If the operator leaves the excavator (e.g. for breaks or at the end of work), the engine must be stopped and the excavator must be secured against restarting by removing the key. The cab door must be locked. Before leaving the excavator, park the machine so that it can not move.
- Whenever work is interrupted, the bucket must always be lowered to the ground.
- Do not allow the engine to run indoors, unless the room is equipped with an exhaust gas extraction system or otherwise well ventilated. The exhaust gas contains carbon monoxide, a colourless, odourless, and lethal gas.
- Never crawl under the excavator before the engine is stopped, the key is removed and the excavator is secured against moving.
- Never crawl under the excavator if it is only raised with the bucket or the dozer. Always use suitable supports.

Guiding the operator

- If the operator's working and driving area is obscured, the operator must be supported by a guide.
- The guide must be capable of performing this kind of work.
- Before starting work, the guide and the operator must agree the necessary signals.
- The guide's position must be clearly visible by the operator.
- The operator must stop the excavator immediately if the eye contact to the guide is interrupted.
→ As a rule, either the excavator or the guide may move, never both at once!

Working in the vicinity of overhead power lines

When working with the excavator in the vicinity of overhead power lines and tram lines, a minimum distance as specified in the following table must be maintained between the excavator and its attachments and the power line.

	Rated voltage [V]	Safe distance [m]
	up to 1 kV	1.0 m
over 1 kV	up to 110 kV	3.0 m
over 110 kV	up to 220 kV	4.0 m
over 220 kV	up to 380 kV or when rated voltage is unknown	5.0 m

If safe distances can not be maintained, the power lines must be switched off in coordination with their owner or provider and secured against making them live again.

When approaching overhead power lines, any possible movements of the excavator must be taken into consideration.

Unevenness of the ground or sloping the excavator can reduce the safe distance.

Wind can cause the overhead power lines to sway, thus reducing the safe distance.

In case of a power cross-over, leave the danger zone with the excavator, if possible, by taking suitable measures. If this is not possible, do not leave the operator's place, warn any approaching persons of the danger, and have the power switched off.

Working in the vicinity of underground power lines

Before starting with excavation work, the owner of the excavator or the person responsible for the work must check if there are any underground power lines in the proposed working area.

If there are underground power lines present, the position and routing of the power lines must be determined together with the owners or operators and the required safety measures must be determined.

If power lines are encountered or accidentally damaged, the operator must stop working immediately and inform the responsible person.

Initial operation

Before initial operation, the excavator must first be checked visually for external transit damages and checked if the shipped equipment is complete as ordered.

- Check fluid levels as described in the "Maintenance" section (page 117).
- For a description of all operation features refer to the "Operating the excavator" section (page 60) as well as the following sections.

If defects are detected, please inform your dealer immediately.

Explanation of the display indications

If the starter switch is switched in position RUN, the time (3), the engine speed (4) and the hours of operation (5) can be indicated in the display (2).

For the selection of the display indication, press the display selector switch (1) until the desired indicator appears in the display.



The following function can be carried out when the key is not in the starter switch.

- Press the display selector switch (1).

In the display, the hours of operation are indicated for about 10 seconds.

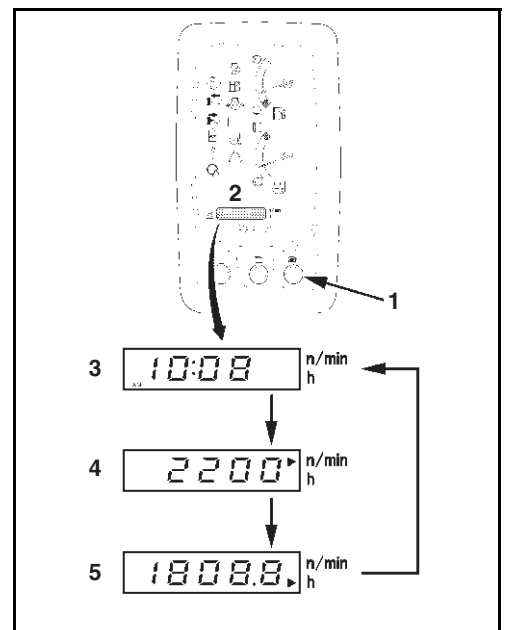

Setting the clock

- Turn the starter switch to the RUN position.
- Press menu button (2).
- Press display selector switch (1) until the clock shows in the display (3).

By pressing and holding of the display selector switch (1) the following are selected in this order: year, month, day, 12 or 24 hour indicator, hours and minutes for adjusting.

- Press display selector switch (1) and hold down.



When carrying out the setting process, the value to be adjusted will blink up in the display and the indicator (4) on the display and control unit.

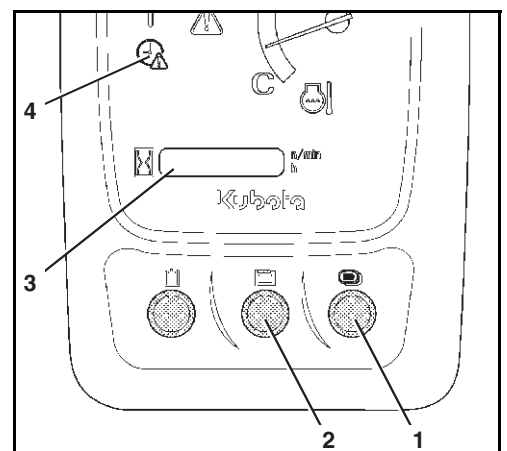

- Press menu button (2) to reduce the numerical value.
- Press display selector switch (1) to increase the numerical value.

- To store the setting of the clock and to finish, press the display selector switch (1) once more and hold it down.



If the battery is separated from the electricity network, the data of the clock are deleted. After re-commissioning the indicator Set clock blinks and requests the renewed setting of the clock.

Running-in of the excavator

During the first 50 hours of operation, the following points should be adhered to in all cases:

- Warm up the excavator at an average engine speed and with a low load; do not let it warm up at idling position.
- Do not overload the excavator.

Special maintenance instructions

- Change the oil in the final drives after the first 50 service hours.
- The hydraulic system's return filter should be changed after the first 250 service hours.

Operating the excavator

For a safe excavator operation, see the following sections.

Pre-operational services



For the performance of the services, the excavator must be parked on level ground and the key must be removed.

- Open the engine compartment cover (page 106). Close engine compartment cover after completion of the activities.
- Open the side cover (page 107). Always close the side cover after the work is done.

Walk-around inspection

- Check the excavator for visible damage, loose nuts and screws and leaks.

Checking the engine oil level

- Pull out the oil dipstick (1) and wipe it with a clean cloth.
- Insert the oil dipstick completely and pull it out again. The oil level should be in the "A" area. If the oil level is too low, refill engine oil at the oil filler neck (page 127).



When the oil level is too high or too low, the engine might get damaged during operation.

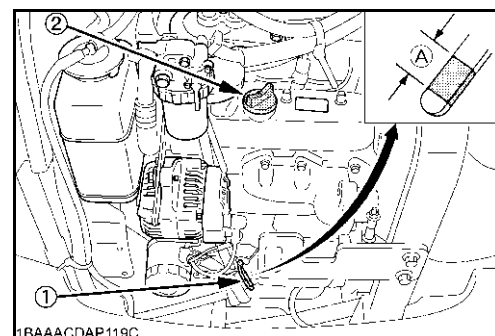

Checking the coolant level

- Check the coolant level in the expansion reservoir (1). The fluid level must be between FULL and LOW.



Do not open the radiator cap.



If the coolant level is below the LOW mark, refill coolant (page 123).

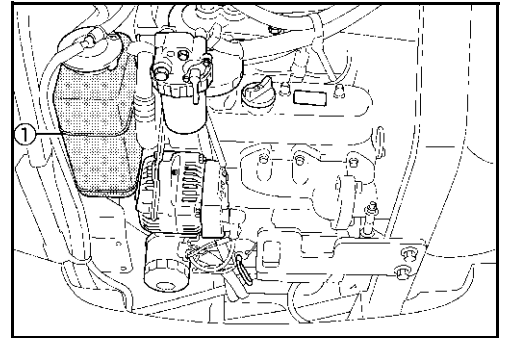

If the coolant level is below the LOW mark a short time after adding coolant, the cooling system is leaky. The excavator may only be started again after the fault is repaired.

Checking coolant radiator and oil cooler

- Walk-around inspection of coolant radiator (1) and oil cooler (2) for tightness and soiling.

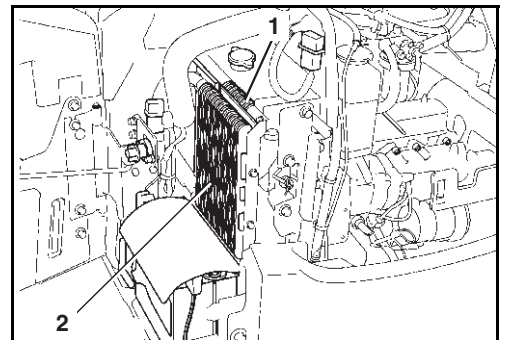

- If there is any dirt etc on the radiators, clean the radiators (page 124).

Checking of the V-belt



*The engine must be switched off and the key removed!
Do not attempt to grasp rotating or moving parts.*

- Press in the V-belt (1) at position "A". The V-belt must give way for approx. 8 mm (pressure: 10 kg). Adjust the V-belts if necessary (page 125).
- Check condition of the V-belt, it must not have any cracks or other damage. Replace the V-belts if necessary (page 125).

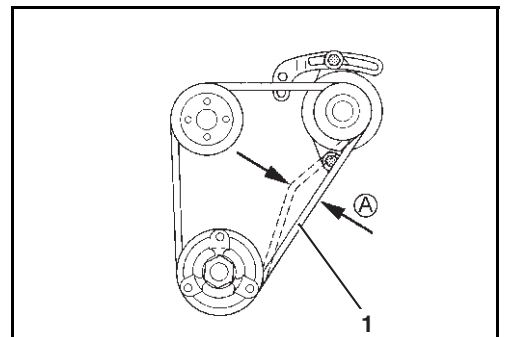

Checking the exhaust system for leaks

- Check the exhaust system for leaks and security (formation of cracks).



If the inspection is carried out when the engine is warm, there is a risk of burns at the exhaust system.

- If the exhaust system is leaky or loose, the excavator may only be taken into operation after the defects are eliminated.

Checking the oil level of the hydraulic system



Operate the boom, arm, bucket and boom swing mechanism so that all hydraulic cylinders are extended half way. Lower the dozer onto the ground. Set extendable track width (KX016-4/KX018-4/KX019-4) to standard track width. See the "Placing out of operation" section (page 92).

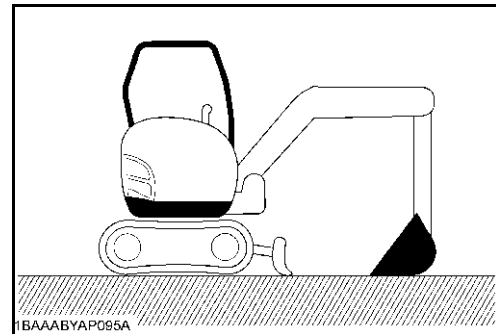

Check the oil level in the sight glass (1). The oil level should be half way up the sight glass. Carefully check the position of the hydraulic cylinders before topping up the oil. For more information see the "Topping up/changing the hydraulic oil" section (page 132).

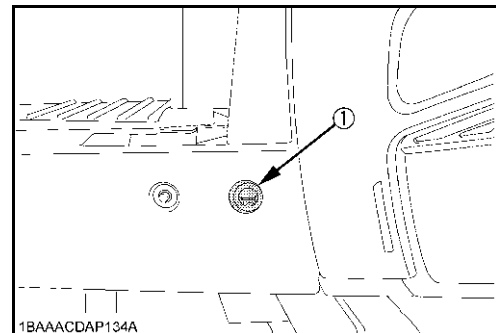

Greasing the bucket bolts and bucket linkage bolts

- Start engine (page 67).
- Position arm and bucket as shown in the figure.
- Stop the engine (page 69).
- Lubricate all greasing points (see figure to the right) – see the "Recommended lubricants" section (page 145) – by injecting grease until fresh grease emerges.



Wipe emerged grease off immediately and store dirty cleaning cloths in the containers provided for disposal.

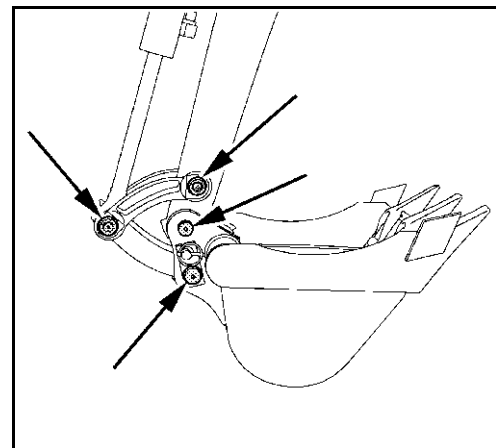

Operation

Greasing the swing bracket

- Lubricate both greasing points (see figure to the right) – see the "Recommended lubricants" section (page 145) – by injecting grease until fresh grease emerges.



Wipe emerged grease off immediately and store dirty cleaning cloths in the containers provided for disposal.

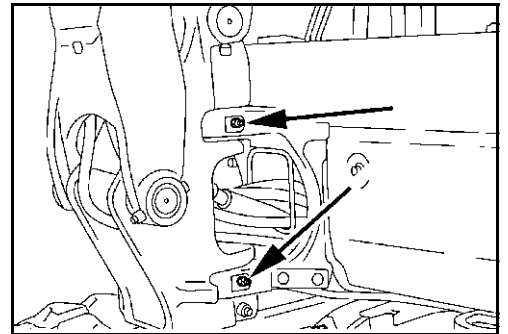

Other greasing points

- Start engine (page 67).
- Position the boom, arm, and dozer as shown in the figure. Stop the engine, remove the key. Refer to the "Operating the controls during excavation work" section (page 77)

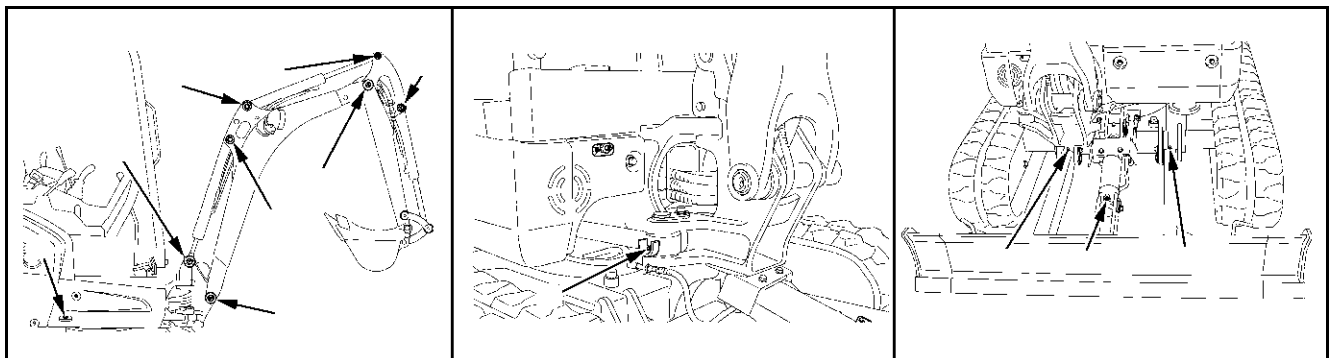

- Lubricate all greasing points with grease – see the "Recommended lubricants" section (page 145) – until fresh grease emerges.



Wipe emerged grease off immediately and store dirty cleaning cloths in the containers provided for disposal.

Checking the electric cables and connections

- Check all accessible electric cables, connectors and connections for condition and security.
- Repair or replace damaged parts.
- Check the fuse box and fuse holders for oxidation and dirt, clean if necessary.

Check the fuel level



The fuel gauge (1) indicates the relative fuel amount in the tank. The less fuel is left in the fuel tank, the lower the dial of the gauge.

- Turn the starter switch to the RUN position.
- Check fuel situation by looking at the fuel gauge on the display and control unit.
- Refuel excavator if there is too little fuel left (page 102).

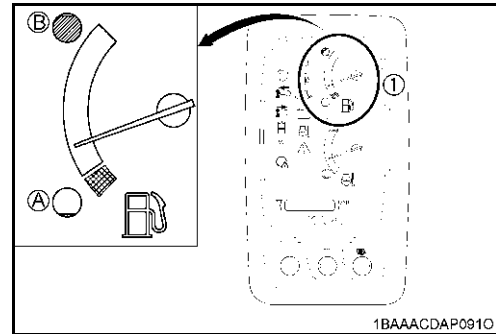

Check the fluid level of the washer system (cab version)



Do not operate the washer system if its reservoir (1) is empty as running dry could damage the pump.

- Check whether the liquid reservoir is full enough.

If the filling volume is too low, fill washer system reservoir (page 102).

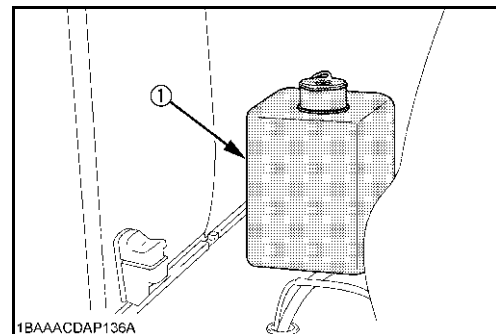

Setting up the workplace

For excavation work with a cab, please consider section titled Opening and closing the cab door (page 96).

Getting on the excavator



Risk of injury when entering or leaving the machine!

When entering or leaving the machine without a secure halt, you can slip and fall down.

- Do not jump up or down the excavator.
- Always hold fast with one hand at the hand rail.
- Pay attention to a safe step.

- Move the left control console (2) up as far as possible by pulling the control lever lock (1) up.



The control console must remain in this position until the engine is started, as the engine can only be started in this position.

- Get into the excavator, use the chain as a stepping aid.
- Sit down on the operator's seat.

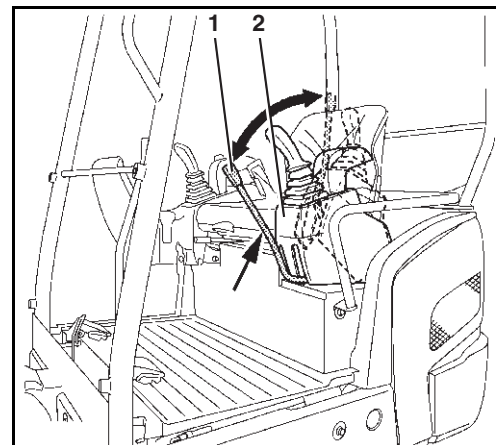

Adjusting the operator's seat (KX015-4/KX016-4)



Adjust the operator's seat so that fatigue-free and comfortable working is possible. It should be possible to operate all controls safely.

Horizontal seat adjustment (seat stand-off)

- Pull the horizontal seat adjustment lever (4) up and move the seat to the desired position by moving it forward or back, then release the lever.

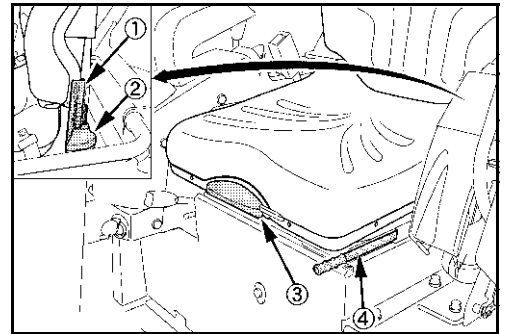

Check that the seat is locked into place.

Spring adjustment (operator's weight)

- The seat can be set to the weight of the operator using the toggle (figure above, position/2). Refer to the weight indicator (figure above, position/1) when choosing your setting.
- Depressing the lever increases spring tension (heavier operator), and pulling up the lever reduces spring tension (lighter operator).
- Adjust the seat so that a comfortable cushioning is achieved.

Backrest adjustment

- Take the load off the backrest and pull up the backrest adjustment lever (figure above, position/3). Set the backrest to the desired sitting position and release the lever. The backrest should be adjusted so that the operator can safely operate the control levers with the back resting completely on the backrest.

Adjusting the operator's seat (KX018-4/KX019-4)



Adjust the operator's seat so that fatigue-free and comfortable working is possible. It should be possible to operate all controls safely.

Horizontal seat adjustment (seat stand-off)

- Pull the horizontal seat adjustment lever (4) up and move the seat to the desired position by moving it forward or back, then release the lever.

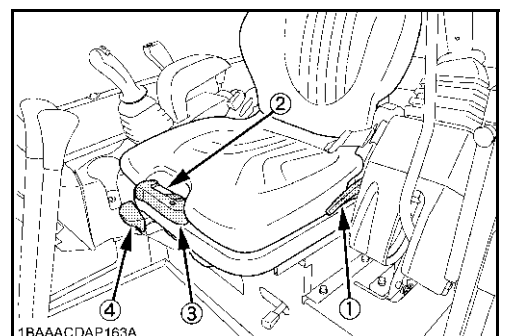

Check that the seat is locked into place.

Spring adjustment (operator's weight)

- The seat can be set to the weight of the operator using the toggle (figure above, position/3). Refer to the weight indicator (figure above, position/2) when choosing your setting.
- Sit down on the operator's seat.
- Swivel the toggle outwards by 90°.
- Pumping up and/or down, change the spring tension until the weight indicator shows your own weight.



Adjust the seat so that the arrow points to the centre of the weight indicator.

Backrest adjustment

Take the load off the backrest and pull up the backrest adjustment lever (figure above, position/1). Set the backrest to the desired sitting position and release the lever. The backrest should be adjusted so that the operator can safely operate the control levers with the back resting completely on the backrest.

Seat belt

- Buckle up.
- Check that the seat belt is fastened tightly.



Do not operate the excavator without the seat belt fastened.

Rear view mirrors adjustment

- Check the adjustment of the rear view mirrors. If necessary, adjust the mirrors until the optimum sight is ensured.

Safety instructions for starting the engine



The excavator is equipped with an anti-theft system (page 108).



When starting the excavator for the first time on a work day, carry out the pre-operational services (page 60).



The safety rules for operation (page 57) are to be observed absolutely!



Make sure that there are no persons within the excavator's working area. It is essential to warn persons in the vicinity of the excavator by briefly honking the horn.



Make sure that all operational controls are in the neutral position.



Starting the excavator is only allowed when the operator is sitting on the operator's seat.



Before starting the engine, make the necessary operator station adjustments (page 64).



If the engine does not start immediately, cease the starting procedure. Wait a short time before re-attempting a start. If the engine does not start after several attempts, contact skilled personnel. If the battery is discharged, jump-start the excavator (page 100).



Do not use Start Pilot or similar substances as a starting aid.

Starting the engine

- Push throttle lever (1) in the following direction .
- Insert the key into the starter switch (2) and turn it to the RUN position.



The excavator is equipped with an anti-theft system. If the excavator is started with a wrong key, the indicator "Pull out key" (figure below/6) lights up on the display and control unit.



If the bunch of keys contains metal parts, such as key rings or other keys, the engine might fail to start.

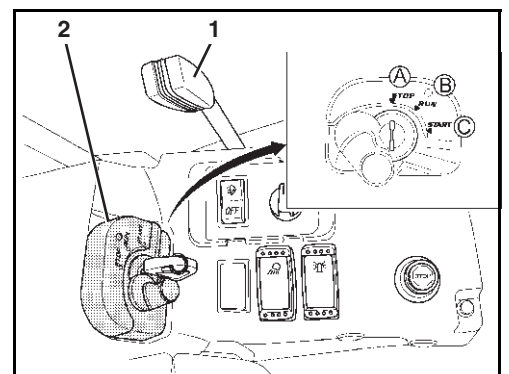

If the control lever lock is not raised, the warning light (5) shines yellow, the engine cannot be started.

The indicator Pre-glowing (1) lights up briefly. The engine can be started after it goes off.

The engine oil pressure indicator (3) lights up and goes out after the engine has been started.

The charge indicator (4) lights up and goes out after the engine has been started.

If the indicators do not light up when the starter switch is in the RUN position, remove the key and contact suitably qualified personnel.

If the fuel reserve indicator (2) blinks yellow, there is only a little fuel left in the tank, refuel excavator (page 102).

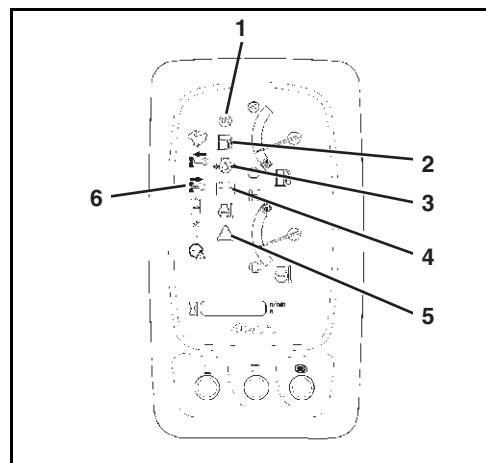

- Turn the starter switch to the START position and hold it there until the engine has started. Release the starter switch.
- Lower the left control console and make sure that the control lever lock engages.
- Let the engine run at middle speed until the operating temperature has been reached.

After the engine has reached its operating temperature, set the engine speed required for operation:

- Pull throttle lever in the direction of  until the required revolutions per minute have been reached

The display selector switch (1) allows you to change between the indication of time, engine speed or hours of operation in the display (2).

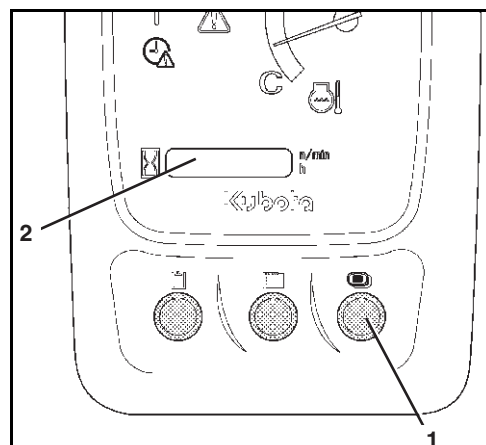

Operation

The time (1) indicates the current time of day in hours and minutes.

The speed indicator display indication (2) indicates the current engine speed.

The hour of operation indicator (3) indicates the hours of operation of the excavator performed up to now, regardless of the engine speed.

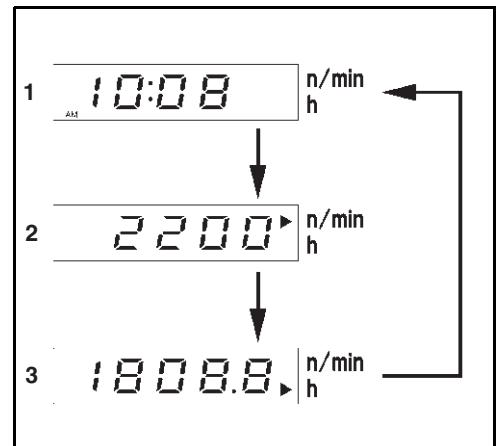

Check the displays and indicators during operation (page 69).

Stopping the engine



If the engine is to be stopped to take the excavator out of operation, the services for placing the excavator out of operation (page 92) must be carried out.

- Turn the starter switch to the STOP position and remove the key.

Observation of the displays after starting and during operation

The operator must observe the display indicators and displays after starting and during operation.



The warning light (1) flashes red when a system fault or technical malfunction occurs. Stop the engine immediately! The warning light flashes yellow when the system issues a warning. Additionally, the display may show an error as in the figure on the right.



Clear the messages by taking appropriate steps, see "Troubleshooting: Display indications" (page 114), or contact qualified personnel if necessary.

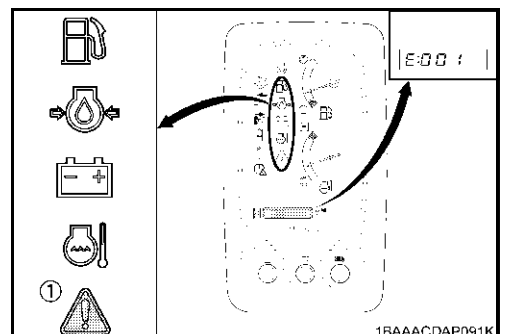

If the engine oil pressure becomes too low during operation, the engine must be stopped immediately. The engine oil pressure indicator (1) lights up, the warning light (2) flashes red and the display message as in the figure on the right appears.

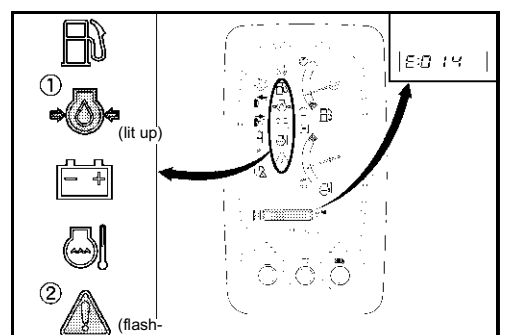

If a fault occurs in the charging system during operation, the engine must be stopped immediately. The charge indicator (1) lights up, the warning light (2) flashes red and the display message as in the figure on the right appears.

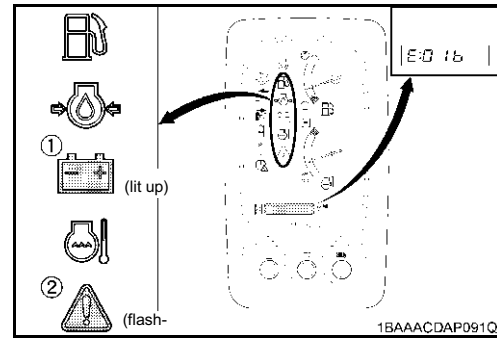

The needle of the coolant temperature gauge (1) should be in the area between "C" (COOL) and "H" (WARM). If the needle rises up to range "H" (Red), cool down the engine by changing into idle.



Allow the machine to idle for five minutes before switching off the engine!

- Check the level of the coolant in the expansion tank.



Do not open the radiator cap → risk of scalding.

- Check the cooling system for leaks; if necessary, contact skilled personnel.
- Check if the V-belt is very loose or broken; if necessary, contact skilled personnel.
- Check if the air intake in the side panel, the radiator, and the oil cooler are very dirty. If necessary: Clean the radiator (page 124).

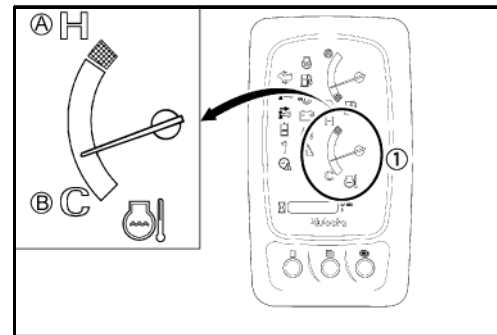

When the machine is being operated at or close to full capacity, the temperature of the coolant can rise a little higher than normal. The indicator Coolant temperature (1) blinks and the message appears in the display as shown in the figure on the right.

The message fades out after a short time and the indicator Coolant temperature blinks as long as the temperature remains elevated.

Operate the machine only with reduced loads until the operating temperature is normal again.

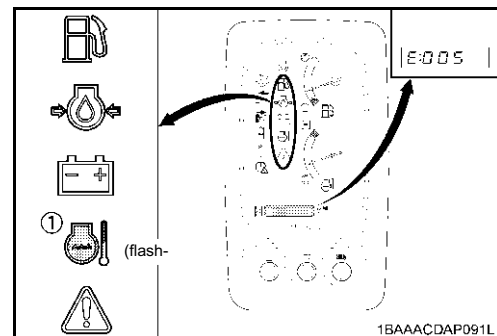

If the coolant temperature is too high, cool down the engine by changing into idle. The display message as in the figure on the right appears.



Allow the machine to idle for five minutes before switching off the engine!

- Check the level of the coolant in the expansion tank.



Do not open the radiator cap → risk of scalding.

- If the water level is below the "LOW" mark, let the engine cool completely and add coolant (page 123).

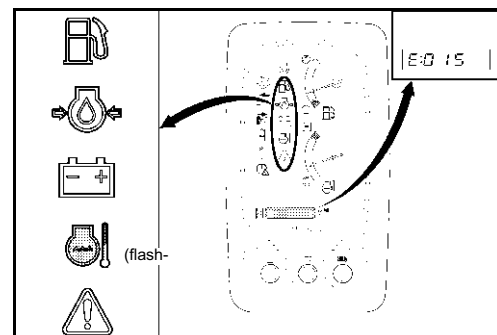

Operation

- Check the cooling system for leaks; if necessary, contact skilled personnel.
- Check if the V-belt is very loose or broken; if necessary, contact skilled personnel.
- Check if the air intake in the side panel, the radiator, and the oil cooler are very dirty. If necessary: Clean the radiator (page 124).
- Watch the fuel gauge (1).



The needle indicates the relative fuel amount in the tank. As fuel is used up during operation, the needle slowly descends.

When the fuel tank is full, the needle points to the top (A).

When the fuel tank is empty, the needle points to the bottom (B).

When the fuel reserve indicator (2) is lit, there is only a little fuel is left in the tank, refuel excavator (page 102).

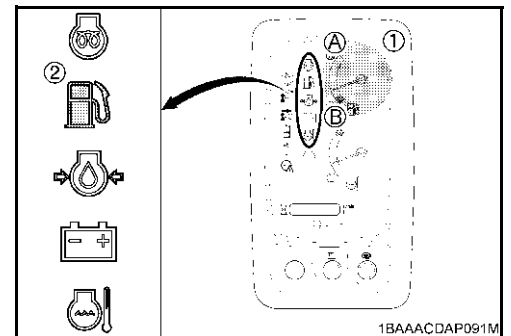

When operating the excavator on a slope, the fuel is displaced to one side of the fuel tank. In this situation, when the fuel level is low, the fuel pump may not deliver enough fuel, causing the engine to stall. The machine must be refuelled and the fuel system bled.



When the fuel tank is empty, the machine cannot be operated. The machine must be refuelled and the fuel system bled.

Also stop the engine immediately if

- the engine speed rises or drops suddenly,
- abnormal noises are heard,
- the excavating devices do not respond to the control lever as expected or
- the exhaust fumes are black or white. When the engine is still cold, white smoke for a short time is normal.

Adjusting of the track width (KX016-4/KX018-4/KX019-4)

For excavator work with extendable track width, please adjust the desired track width before you start.

The track widths are:

- Standard track width (A): 1240 mm (KX016-4) resp.
1300 mm (KX018-4/KX019-4)
- Narrow track width (B): 990 mm

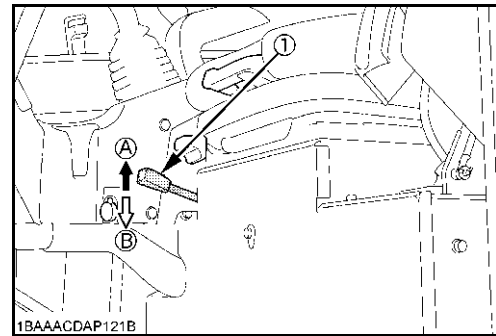

Caution - risk of tipping!

When carrying out excavating work using narrow track width, the excavator will become more instable. The narrow track width should be used only for passing through narrow areas.

- As a general rule, perform any excavator work using standard track width (A).
- The excavator may not be operated with the narrow track width (B).



To adjust the respective track width, both track width cylinders must be either completely extended (standard track width, A) or retracted (narrow track width, B).

- Pull up the extendable track width lever (1).
The track width is increased from narrow track width (B) to standard track width (A).
- Push the extendable track width lever (1) down.
The track width is reduced from standard track width (A) to narrow track width (B).

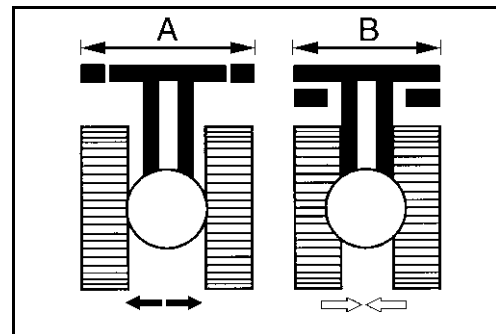

When driving with narrow track width the dozer enlargement must be folded in (page 72).

Adjusting of the dozer width (KX016-4/KX018-4/KX019-4)

Set blade width to narrow track width

- Pull out locking bolt (1).
- Fold away dozer enlargement (2) behind dozer.
- Reinsert locking bolt (1).



Carry out this activity on both sides of the dozer.

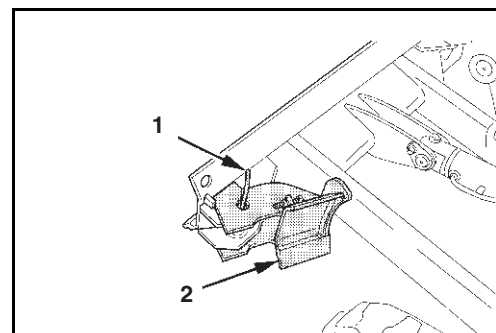

Operation

Set blade width to standard track width

- Pull out locking bolt (1).
- Fold out dozer enlargement (2) to the front.
- Reinsert locking bolt (1).



Carry out this activity on both sides of the dozer.

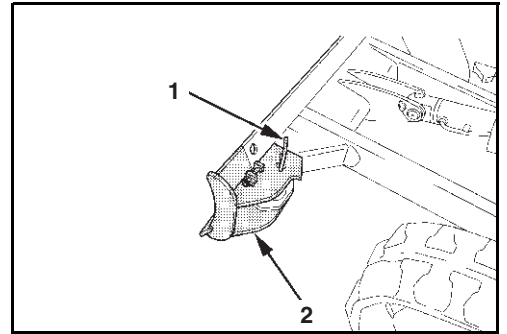

Driving the excavator

- Adhere to the general safety rules (page 13) and the safety rules for operation (page 57).
- Carry out the pre-operational services (page 60).
- Start the engine (page 67).
- Observe the displays and indicators (page 69).



Ensure that the boom and the dozer are in the direction of travel as shown in the figure.

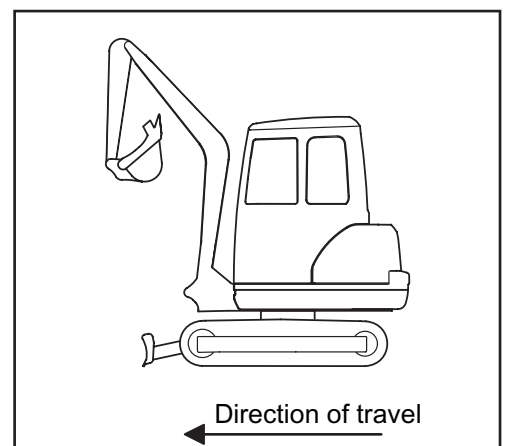

When driving with the excavator, always observe the following safety instructions.

When working on slopes, observe the tilt of the excavator (see figure).

Climbing performance → 27 % resp. 15°

Max. lateral sway → 18 % resp. 10°

- Keep the bucket as low as possible when driving.
- Check the ground for stability, and verify if there are holes or other potential obstacles.

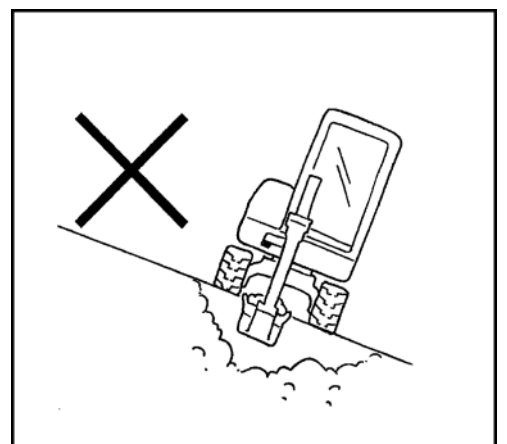

- Approach overhangs and edges of ditches carefully as they could cave in.
- Drive slowly downhill, do not allow the vehicle speed to increase uncontrollably.
- Close the cab door (cab version).
- When driving, the bucket should be approx. 200 to 400 mm (A) over the ground (see figure).
- Raise the dozer to the top position.
- Select an appropriate engine speed.

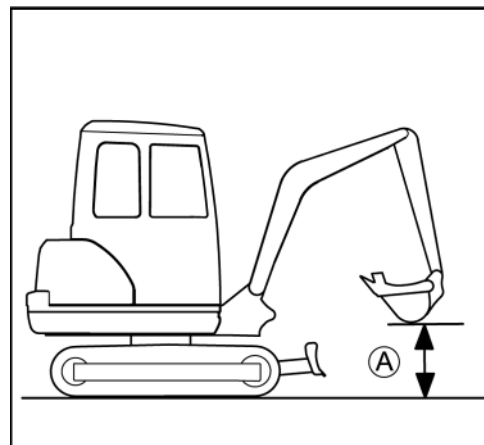

Driving

- Push both drive levers forward simultaneously to drive the excavator straight ahead. Releasing the drive levers stops the excavator immediately. To reverse the excavator, pull both drive levers back simultaneously.

- (A) Forward
- (B) Reverse
- (C) Straight ahead



If the dozer is not at the front, as shown in the figure, but at the rear, the operation of the drive levers is exactly opposite. Drive lever forwards:

→ The excavator backs up.

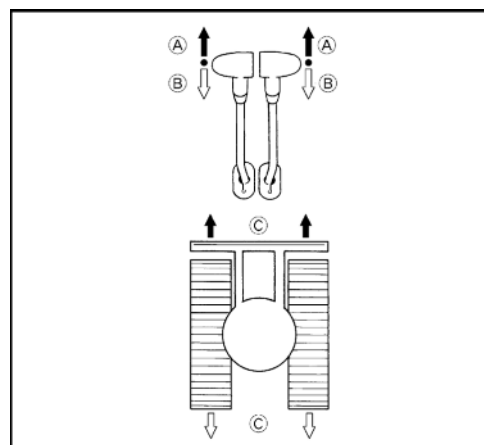

- To drive faster, press the travel speed button (1).

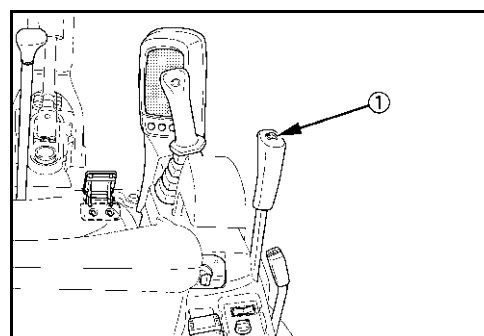

Operation

A tone sounds and the indicator (1) shines. Renewed operating of the push button travel speed switches back to normal speed. Besides, audible signal sounds and the indicator goes out.

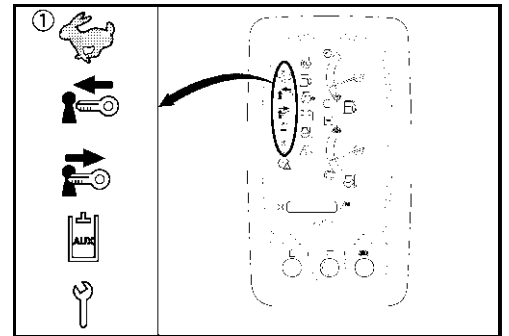

Do not drive fast on muddy or uneven terrain, also if another control is operated (e.g. turning the swivel frame).

Turning



Turns are described for the forward direction of travel with the dozer at the front. If the dozer is positioned at the rear, the steering movements should be in the opposite direction.



When making turns, be sure nobody is standing within the swing area of the excavator.

During driving

- Pull the left drive lever to neutral, leave the right drive lever pushed forward.

(A) The excavator makes a left turn.

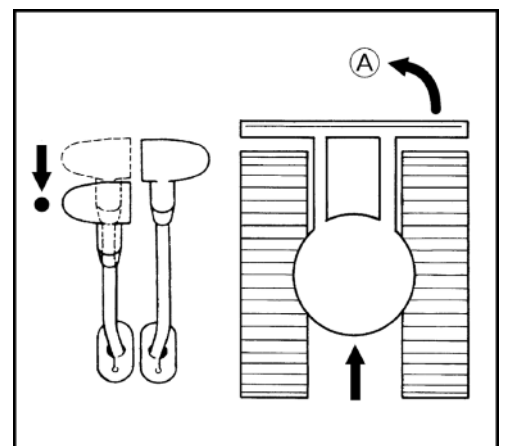

From a standing position

- Leave the right drive lever in neutral, push the left drive lever forward. In this case, the turning radius is determined by the right track.

(A) The excavator makes a right turn.

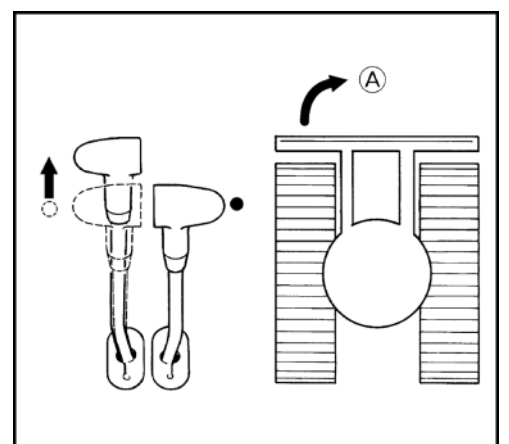

Turning on the spot



Do not make a turn on the spot with the travel speed button actuated.

- Move the drive levers in opposite directions. The tracks will turn in opposite directions. The centre of the vehicle is its vertical axis.

(A) Turning on the spot to the right.

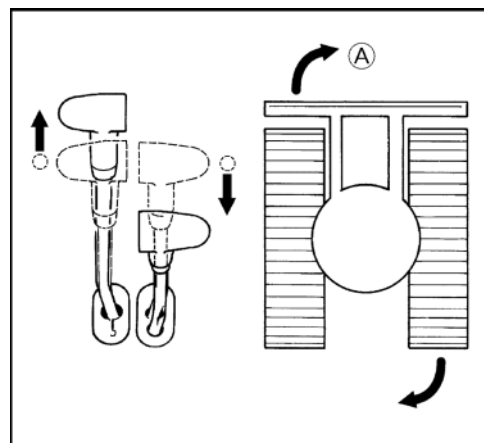

Driving uphill and downhill



Exercise extreme caution when driving up and down a slope. Do not use the travel speed button.

- When driving on gradients, raise the bucket approx. 200 to 400 mm (A) above the ground (see figure).

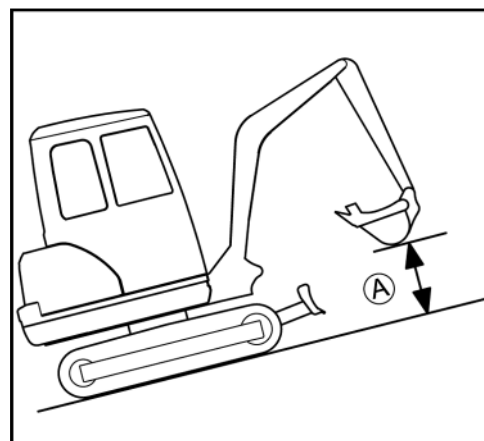

- When driving on gradients, let the bucket slide over the ground if the terrain allows it.

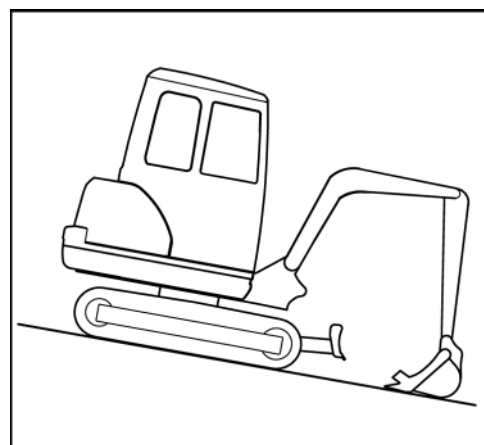

Notes for rubber crawler operation

- Driving or turning on sharp objects or over steps causes excessive wear on the rubber crawlers and will lead to breaking of the rubber crawler or cause the crawler running surface and the steel inserts to be cut.
- Make sure that no foreign objects get stuck in the rubber crawler. Foreign objects lead to excessive crawler wear and can cause it to break.

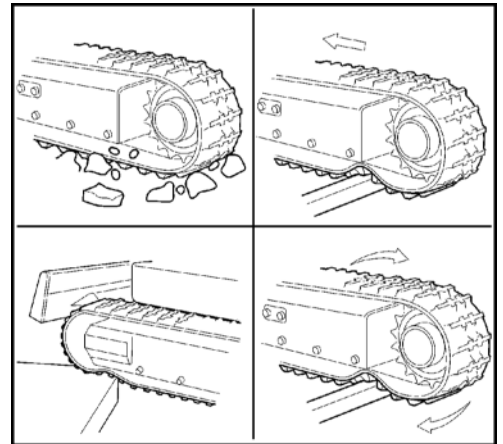

- Keep oil products away from the rubber crawlers.
- Remove any fuel or hydraulic oil spilled on the rubber crawlers.

Making sharp turns

- On streets with a high-friction tarmac, e.g. concrete, do not make sharp turns.

Protecting the crawler against salt

- Do not work with the machine on the seashore. (The salt will cause the steel insert to corrode.)

Operating the controls during excavation work



Always observe the following safety instructions when working with the excavator.

- Never crush concrete or boulders using side boom swings with the bucket.
- Do not use the dropping action of the bucket for excavation.
- Never fully extend the cylinders. Always keep a certain safety margin, especially when operating with a breaker (accessory).
- Never use the bucket as a hammer to drive posts into the ground.
- Do not drive or dig with the bucket teeth rammed into the ground.
- When loading soil, do not dig the bucket deeply into the ground. Instead, make relatively shallow slices with the bucket out as far as possible. This technique reduces the stress on the bucket.
- When working in water, the water should only reach up the lower edge of the swivel frame.
- After using the machine in water, always grease the pins at the bucket and arm with grease until the old lubricating grease emerges.
- When digging in reverse direction, pay attention that the boom does not get into contact with the dozer.
- It is forbidden to use the excavator for crane works, unless it is equipped with a pipe safety valve for crane operation (accessories) according to DIN EN 475-5).

- Adhering soil can be shaken off when the bucket is being emptied by moving the cylinder to the end of the stroke. Should this not suffice, dump the arm as far as possible and operate the bucket back and forth.
- When excavating, always lower the dozer completely onto the ground.

Note on using wider and deeper buckets



When using a wider or deeper bucket, take good care when swinging or retracting the front attachments to make sure that the bucket does not hit the cab.

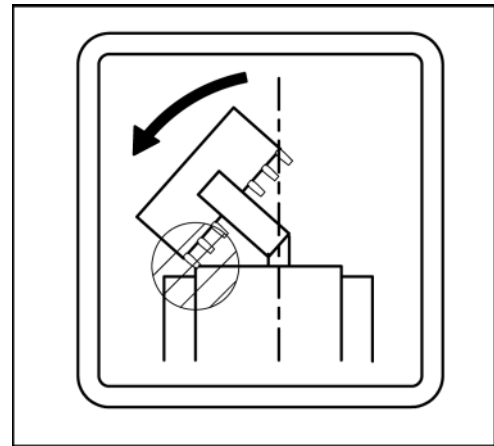

Operating the dozer



When working with the dozer, operate both drive levers with the left hand and the dozer control lever with the right hand.

- To lift the dozer, pull the dozer control lever (1) back.
- To lower the dozer, push the dozer control lever forward.

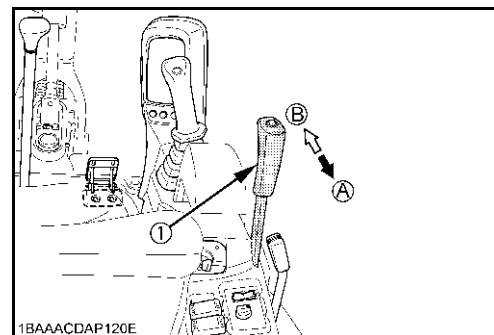

(A) Dozer up.

(B) Dozer down.

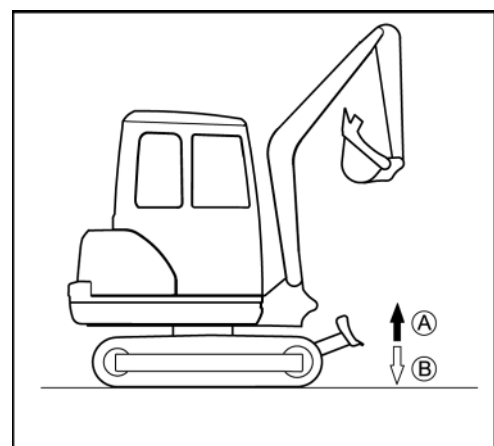

Operation

Overview of control lever functions

The figure shows, in connection with the following table, the functions of the left and right control levers.

Control lever		Movement
Right control lever	1	Lower boom
	2	Raise boom
	3	Bucket crowd
	4	Bucket dump
Left control lever	A	Arm crowd
	B	Arm dump
	C	Swivel frame to the left
	D	Swivel frame to the right

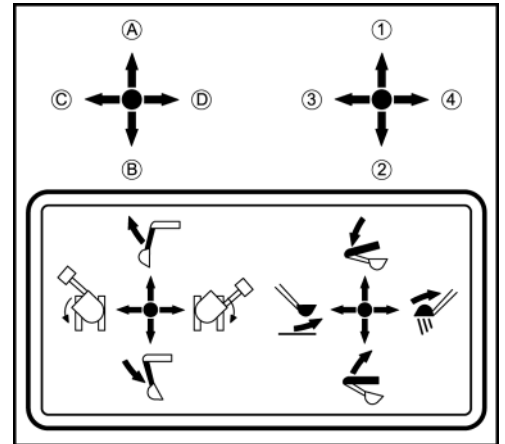

Operating the boom

If the excavator is overloaded, the boom must be lowered until the load rests on the ground. To prevent personal injuries and damage to equipment, do not operate any other functions (e.g. moving the swivel frame).

- To raise the boom, pull the right control lever back (figure/↖).



The hydraulic cylinder of the boom is equipped with a cushioning function, which prevents the excavated material in the bucket from falling out. When the hydraulic system operating temperature is low, the cushioning is delayed for approx. 3 to 5 s. This delay is due to the viscosity of the hydraulic oil and is not a malfunction.

- To lower the boom, push the right control lever forward (figure/↗).

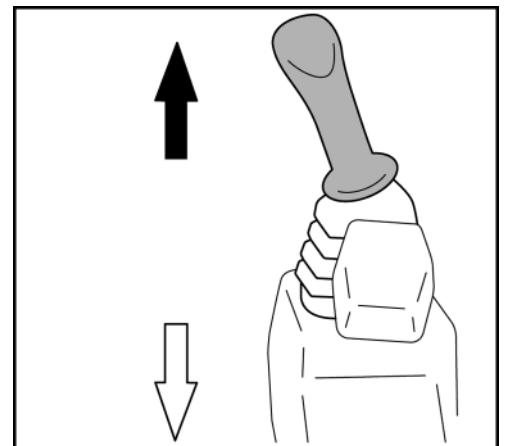

Watch the boom during lowering, so that the boom or the bucket teeth do not hit the dozer.

The boom moves as shown in the figure.

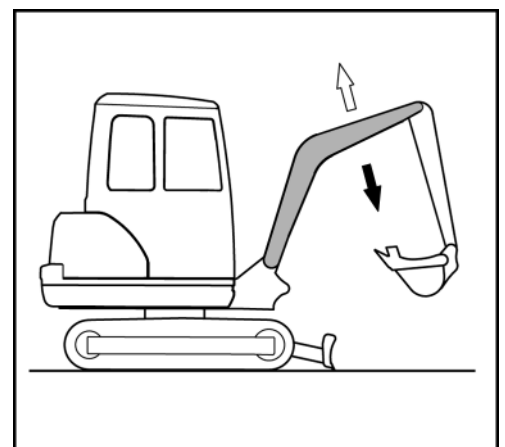

Operating the arm

- To dump the arm, push the left control lever forward (figure/↑).
- To crowd the arm, pull the left control lever back (figure/↓).

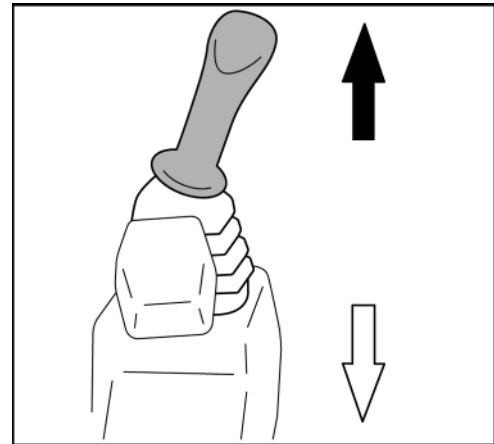

The arm moves as shown in the figure.

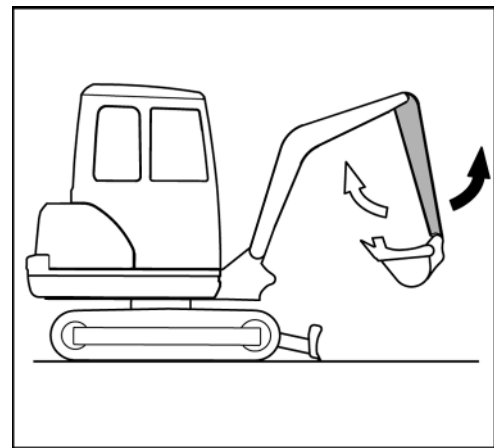

Operating the bucket

- To crowd (digging) the bucket, move the right control lever to the left (figure/←).
- To dump (empty) the bucket, move the right control lever to the right (figure/→).



When crowding the bucket, take care that the teeth do not hit the dozer.

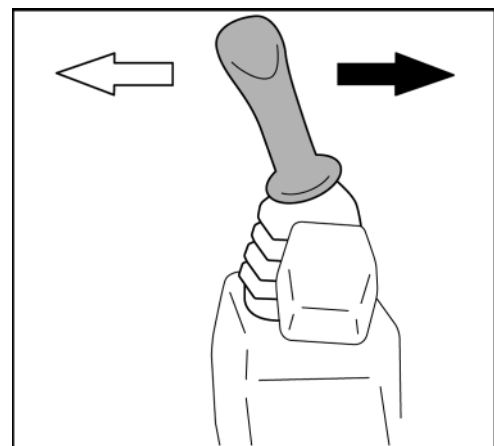

Operation

The bucket moves as shown in the figure.

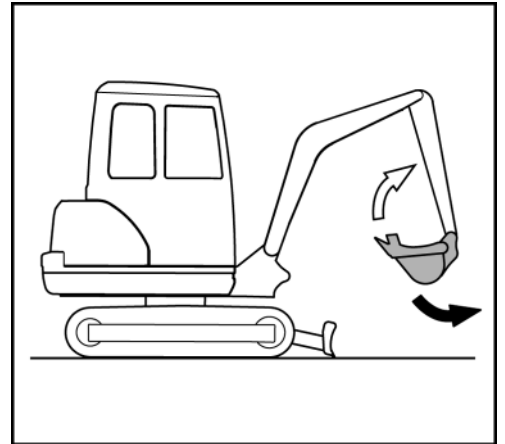

Swivelling the swivel frame



No person is allowed to stand in the swivel area during the movement.



Swivel carefully to avoid any contact of the front attachments with adjacent objects.

- To turn anticlockwise, move the left control lever to the left (figure/←).
- To turn clockwise, move the left control lever to the right (figure/⇒).

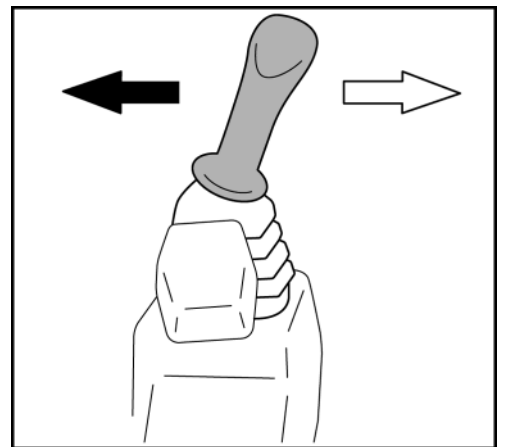

The turning operation takes place as shown in the figure.

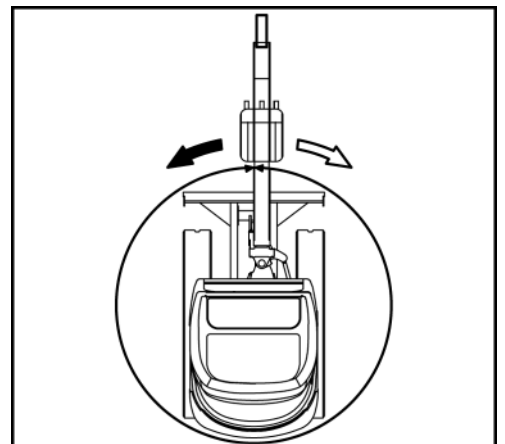

Swinging the boom



No person is allowed to stand in the swing area during the movement.



Swing carefully to avoid any contact of the front attachments with adjacent objects.

- To swing the boom counter-clockwise, press the boom swing pedal on the left-hand side (figure/←).
- To swing the boom clockwise, press the boom swing pedal on the right-hand side (figure/⇒).

The figure details the swing movement.

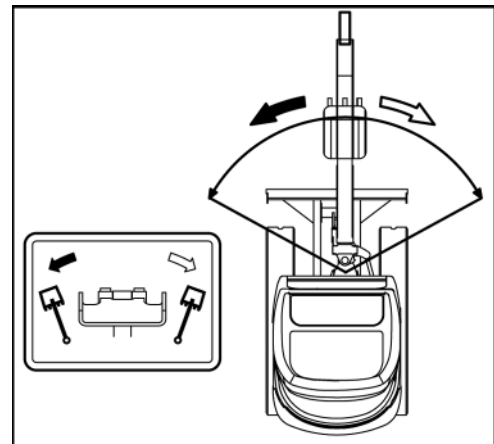

The boom swing control pedal can be secured against inadvertent operation by lowering the locking flap. Fold the locking flap when the boom swing pedal is not in use.

Operating of the auxiliary port (KX015-4/KX016-4/KX018-4)

The auxiliary port serves for operating attachments.



Only implements approved by KUBOTA may be used. The implements must be operated in accordance with the operating instructions supplied with them.



With the use of a hydraulic hammer or another attachment for demolition work, where material is removed and can uncontrollably sputter away, personal protective equipment is absolutely to be worn (safety shoes, safety helmet, eye protection, ear protection and if necessary facial mask). The use of a gravel guard (front protective grid) is recommended. For excavation work with a cab, the front window must be closed, in addition.



The performance data for the auxiliary port can be found in the section "Specifications" (page 39).



Make sure that, before carrying out the activities in the auxiliary port connectors, the pressure relief of the hydraulic equipment (page 90) and the auxiliary port connectors (page 91) has been carried out. Depending on the operation setting, the return change valve has to be set to the appropriate position (page 90).



The auxiliary ports may only be activated when an implement is attached.



If the auxiliary port has not been used for a longer time, dirt particles could have accumulated at the connectors of the conduits. Before installing the implement, drain approx. 0.1 L of hydraulic oil at each port.



Catch the drained hydraulic oil in a container and discard it in accordance with the valid environmental regulations.

- Start the engine (page 67) and keep it at idle speed until the operating temperature has been reached.

Operation



The auxiliary port pedal (1) can be protected against unintentional operating by turning the locking flap (2). If the auxiliary port pedal is not used, the locking flap must be folded in.

- When operating the right pedal part (figure /↘) there is an oil flow at the connector (figure below/1).
- When operating the left pedal part (figure /↙) there is an oil flow at the connector (figure below/2).

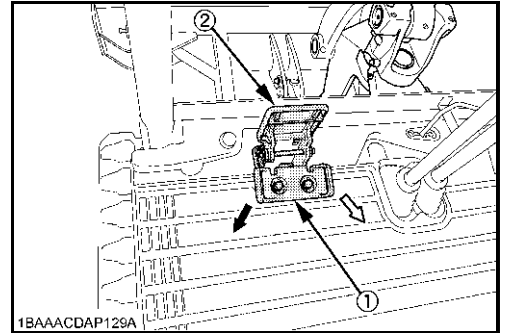

1. Connector for right pedal part
2. Connector for left pedal part

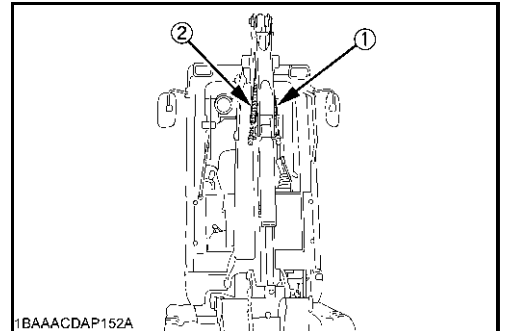

Operating of the auxiliary port (KX019-4)

The auxiliary port serves for operating attachments.



Only implements approved by KUBOTA may be used. The implements must be operated in accordance with the operating instructions supplied with them.



With the use of a hydraulic hammer or another attachment for demolition work, where material is removed and can uncontrollably sputter away, personal protective equipment is absolutely to be worn (safety shoes, safety helmet, eye protection, ear protection and if necessary facial mask). The use of a gravel guard (front protective grid) is recommended. For excavation work with a cab, the front window must be closed, in addition.



For auxiliary port specifications, see the "Specifications" section" (page 39).



Make sure that, before carrying out the activities in the auxiliary port connectors, the pressure relief of the hydraulic equipment (page 90) and the auxiliary port connectors (page 91) has been carried out. Depending on the operation setting, the return change valve has to be set to the appropriate position (page 90).



The auxiliary ports may only be activated when an implement is attached.



If the auxiliary port has not been used for a longer time, dirt particles could have accumulated at the connectors of the conduits. Before installing the implement, drain approx. 0.1 L of hydraulic oil at each port.



Catch the drained hydraulic oil in a container and discard it in accordance with the valid environmental regulations.

- Start the engine (page 67) and keep it at idle speed until the operating temperature has been reached.

Activating the auxiliary port function

The auxiliary port is used for hydraulic implements, such as a breaker. You can set the flow rate prior to operating auxiliary port. Refer to the section for the flow rate setting (page 86) for details.

Switch on the auxiliary port using the auxiliary port enable switch (1). This switch is active when the left control console is lowered and the starter switch is in the RUN position. When the auxiliary port is switched on, the indicator Auxiliary port (2) comes on or flashes.

Using this switch, you can also set the operation settings.

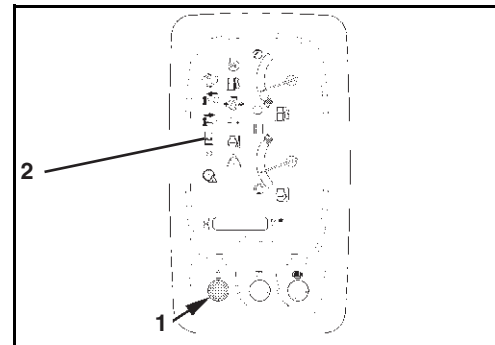

The proportional control enables you to smoothly control the implement speed. Example: If you move the rocker switch half a turn to the left, the implement moves at half speed.

- Move the auxiliary port (1) rocker switch in direction (A). The oil will flow towards connector (A) on the right side of the arm.
- Move the auxiliary port (1) rocker switch in direction (B). The oil will flow towards connector (B) on the left side of the arm.

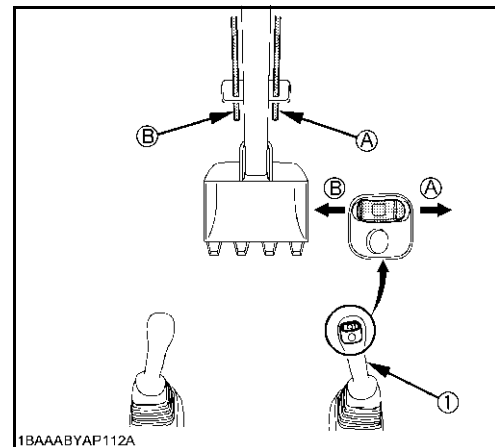

One way hold operation



For one way hold operation, the return change valve has to be set to the direct return flow position (page 90).

- Activate the operation setting for the "one way flow".

Switching on

- Briefly press one way hold switch (1), the oil flow flows unilaterally to the auxiliary port connectors (B) on the left side of the arm.

Switching off

- Briefly press the one way hold switch to switch off the oil flow, or
- press the rocker switch for auxiliary port 2 (3) briefly to the right or left to stop the oil flow.

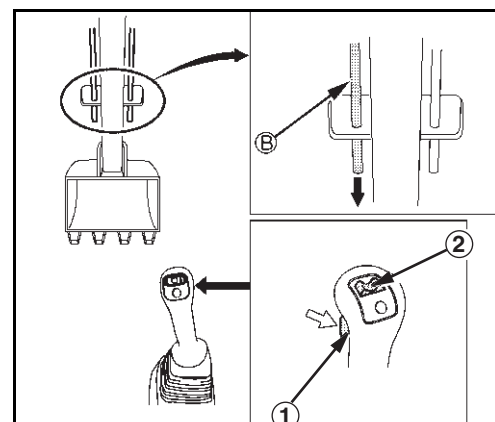

Operation

Operating modes

The auxiliary port connector is preset at the factory, enabling four operating modes to be selected. Up to six operating modes can be preset.

Whenever the auxiliary port button is pressed the service mode changes by one level.



When the starter switch is turned to the RUN position the most-recently used setting is activated.

Select the mode of operation

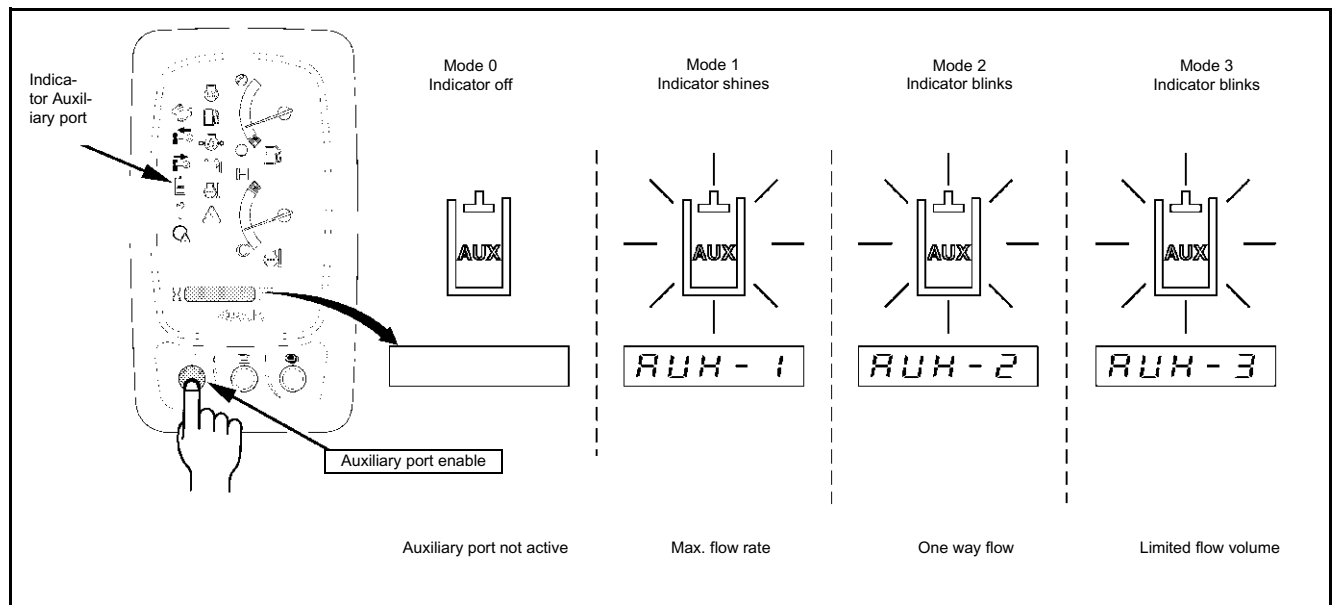

If the auxiliary port is switched on and a mode of operation has been selected, the set flow rate in the right auxiliary port connector and then in the left auxiliary port connector is indicated for few seconds in the display (2) by pressing the display selector switch (1).

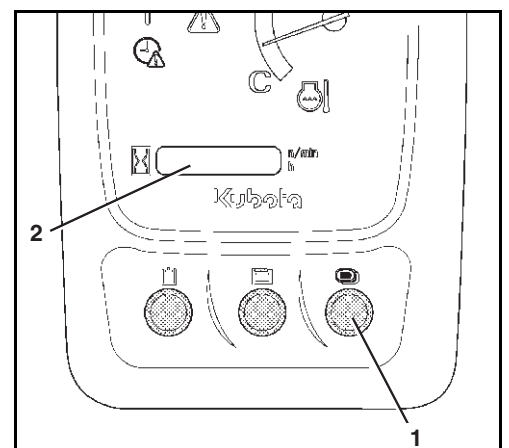

- Ⓐ Selected mode of operation
- Ⓑ Right auxiliary port connector
- Ⓒ Selected flow rate level
- Ⓓ Left auxiliary port connector

After the indication of the flow rates the selected mode of operation is indicated in the display once more.

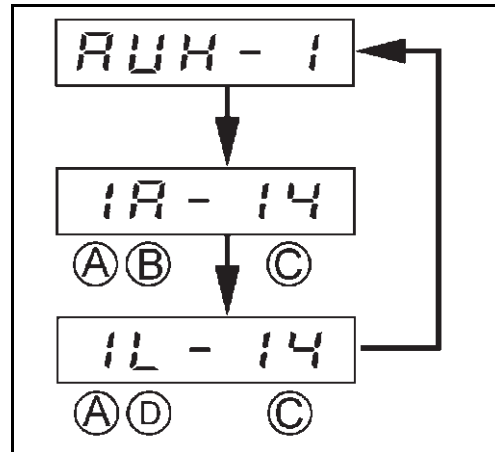

Flow rate setting

Suppose the same implement has to be attached to a different excavator. Even when using identical flow rate settings for the other excavator, the working speed may differ. For each excavator, you need to individually adjust the flow rate settings. Upon changing the implement, you need to determine and adjust the optimum flow rates for the new implement.



The flow at auxiliary port 1 is not constant when using a different function or if a relief valve is responding.



It is recommended to adjust this setting during the operation of the implement.

- Turn the starter switch to the RUN position.
- Press menu button (2).
- The display message as in the figure on the right appears.
- Press display selector switch (1) until AUX is shown in the display.
- To toggle between the operating modes, press and hold the display selector switch (1) again.
- Press the display selector switch (1) repeatedly until the desired indicator appears in the display.
- Press and hold the display selector switch until the selected operating mode's flow rate is shown on the display.

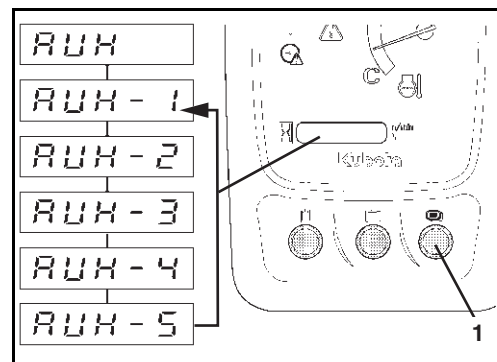
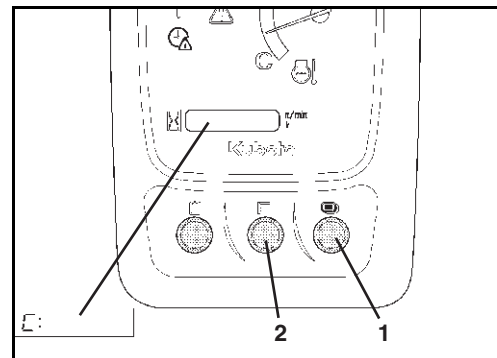

Operation

When the selected flow rate is shown on the display, you can use the display selector switch (1) and the menu button (2) to increase or decrease the flow rate.

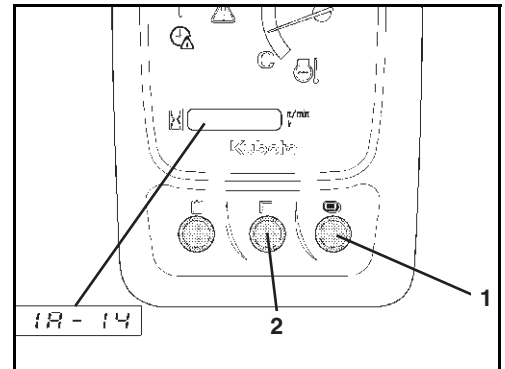

- Press the menu button (2) to decrease the flow rate.
- Press the display selector switch (1) to increase the flow rate.

The flow rate can be increased or decreased in 14 steps.

→ At the highest step, the flow rate reaches its maximum level.

→ If the flow rate is at the lowest level, flow is blocked and there is no oil flow.

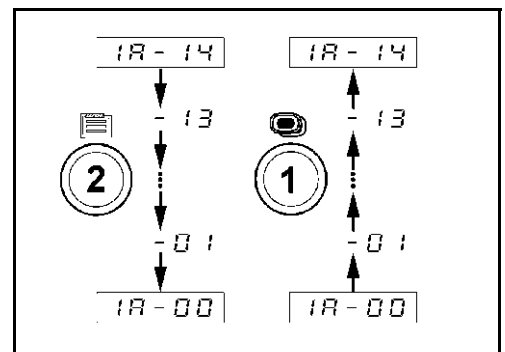

- Press and hold the display selector switch (1) until the flow rate setting changes to left AUX port.



You can switch continuously between the left and right AUX port flow rate settings.

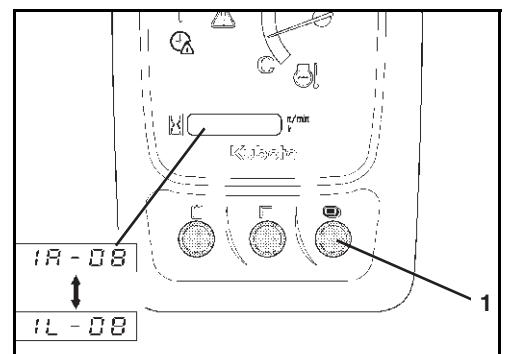

After setting the flow rate for the operating mode selected, you can either switch to the next operating mode or exit the settings screen.

To change the operating mode:

- To toggle between the operating modes, press and hold the menu button (2).
- Press the display selector switch (1) to select the next operating mode.
- Set the flow rate for the next operating mode selected.

To finish the flow rate setting:

- To toggle between the operating modes, press and hold the menu button (2).
- Press and hold the display selector switch (1) to finish the flow rate setting.
- Press the menu button (2) again to return to the normal display screen.

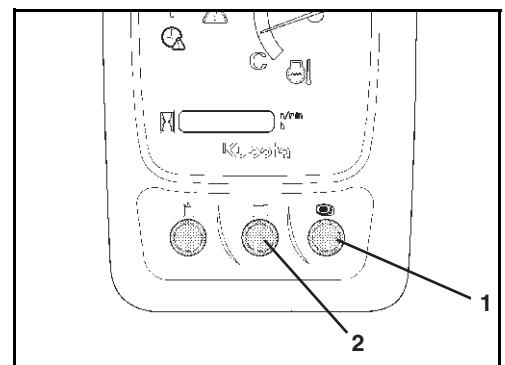



When the flow rate setting value is set to Zero for both AUX ports in a certain operating mode, this operating mode will not be indicated when pressing the auxiliary port enable switch (figure below, position/1). During operation of the excavator, only those modes with a flow rate greater than Zero will be available.

The example in the adjacent graphics shows that only mode 1 and mode 2 have been assigned a flow rate. Each time the auxiliary port enable switch (1) is pressed, the display screen toggles between mode 1 and mode 2 and the default display screen.

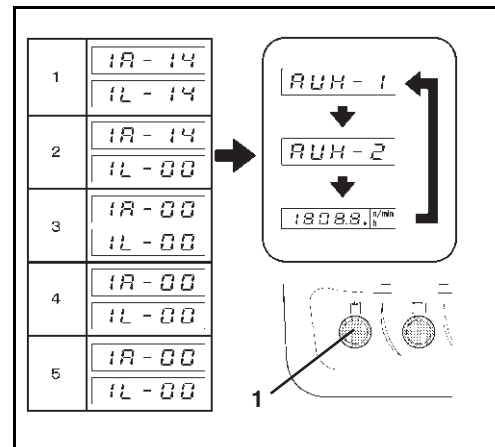

Setting the maximum flow rate

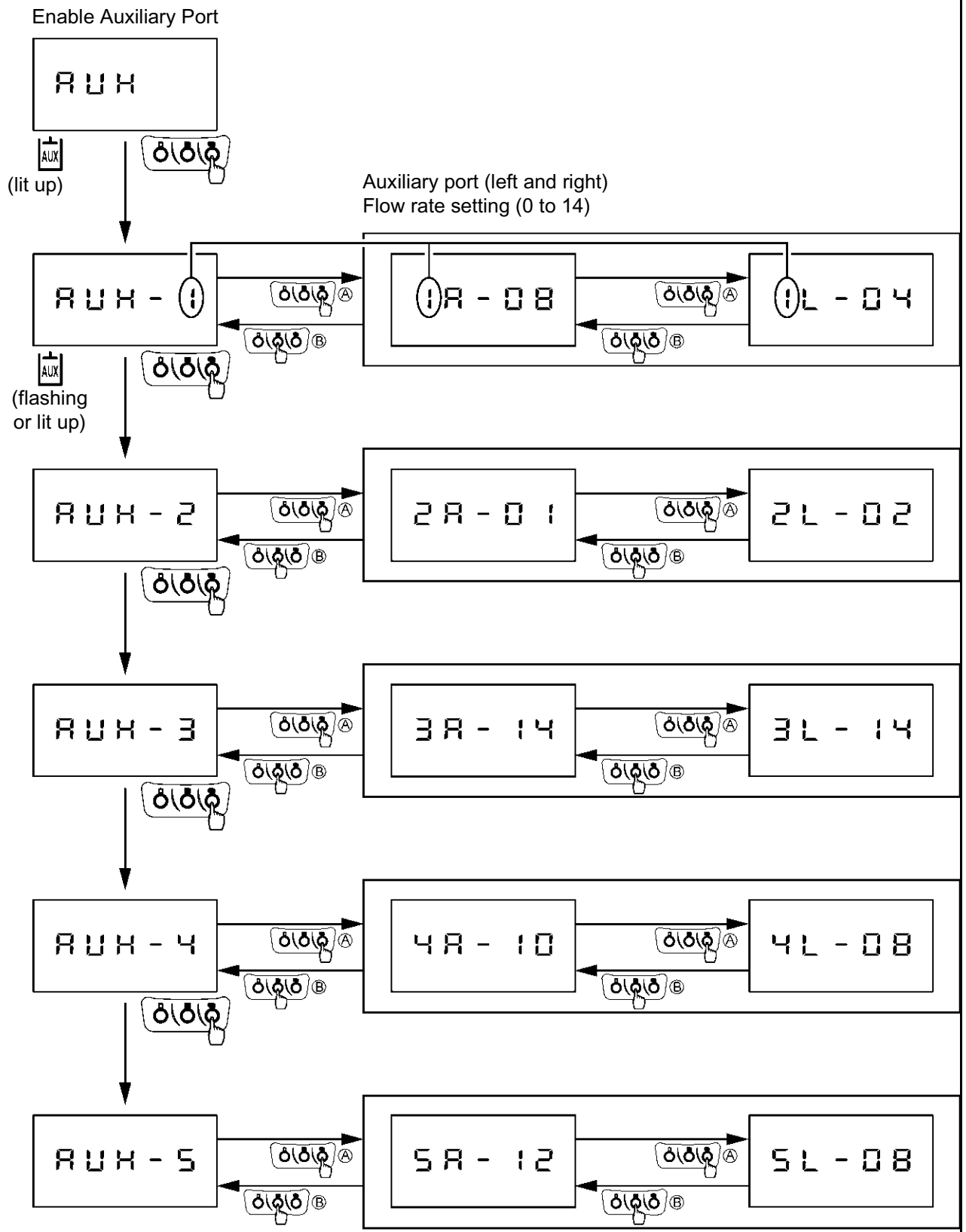

(A) Press and hold the display selector switch.
 (B) Press and hold the menu button.

Return change valve for direct return flow

The change valve (1) has two switch positions.

When "direct return flow" is enabled, the return flow is directed from the implement to the hydraulic oil tank via the return filter. The return flow is only via the right auxiliary port connector at the arm.

When "indirect return flow" is enabled, the return flow is directed from the implement to the return filter via the control valve and then to the hydraulic oil tank. In this case, return flow can be via the left or right connectors (according to the position of the auxiliary port pedal and/or the rocker switch auxiliary port) of the arm.

Move the return change valve to the required position as shown in the figure, depending on the action of the implement being used (rotary or breaking).

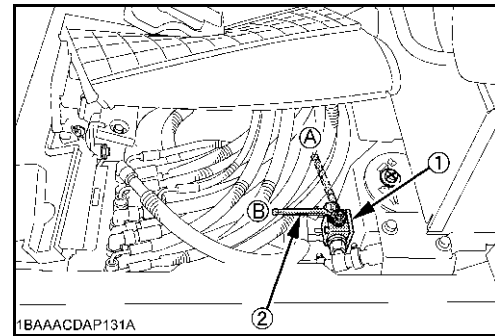

If the change valve is in position "direct return flow", although an attachment with indirect return flow has been mounted, the return flow to the hydraulic tank remains open!

This can lead to sudden movements or falling down of the attachment, even if the machine has been switched off.

- Make sure that the change valve is switched according to the attachment.

Pressure relief of the hydraulic system

- Lower front attachments and dozer completely.
- Turn the starter switch to the STOP position.
- Wait until the engine has come to a standstill.
- Turn the starter switch to the RUN position.

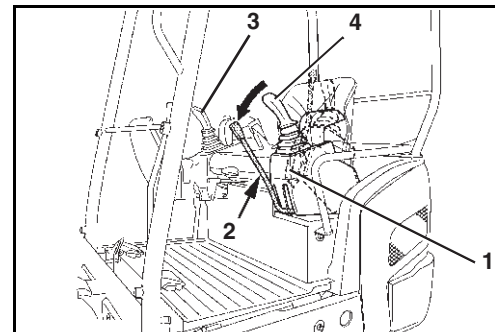

Do not start the engine!

- Lower the left control console (1) and make sure that the control lever lock (2) engages.
- Move control levers (3 and 4) several times to limit stop in all directions.

The hydraulic system is pressure relieved.

Operation

Pressure relief of the auxiliary port (KX019-4)

- Lower front attachments and dozer completely.
- Turn the starter switch to the STOP position.
- Wait until the engine has come to a standstill.
- Turn the starter switch to the RUN position.



Do not start the engine!

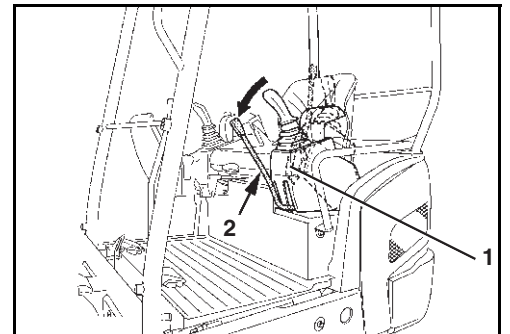

- Lower the left control console (1) and make sure that the control lever lock (2) engages.
- Press the auxiliary port enable switch (1) and turn on the auxiliary port function.

When the auxiliary port is switched on, the indicator Auxiliary port (2) comes on or flashes.

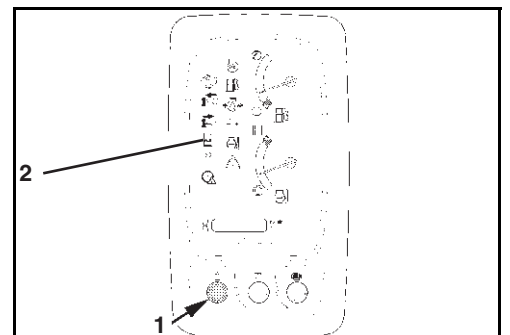

The set flow rate in the right auxiliary port connector and then in the left auxiliary port connector is indicated for few seconds in the display by pressing the display selector switch (1).

If the flow rate is at the lowest level (zero), flow is blocked and there is no oil flow.



If the flow is blocked, the pressure cannot be relieved completely. The hydraulic couplings at the auxiliary port connectors can jam as a result. Then connection or separation of the hydraulic cables of attachments is not possible. Switch to a different mode, if available (page 85), or increase the flow rate (page 86).

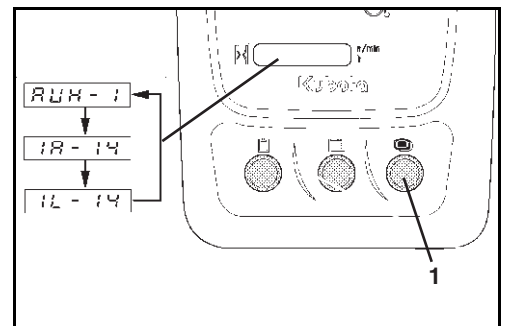

- Make sure that the flow rates are not set to the lowest level.

- Rocker switch auxiliary port (3) on the right control lever must be pushed over completely to the right and left.

The auxiliary port connectors (1 and 2) are pressure relieved.

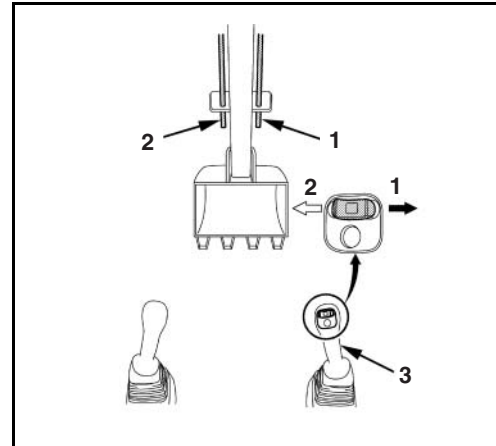

Placing out of operation



Park the excavator in such a way that it can not move and is secured against unauthorised use.

- Drive the excavator onto level ground.
- Extend the hydraulic cylinders as follows:

Boom:	Half-extended
Arm:	Half-extended
Bucket:	Half-extended
Dozer:	Lowered to the ground
Swing mechanism:	Front attachments lowered centrally to the ground
- Stop the engine (page 69).
- Remove the key.
- Unbuckle the seat belt and lift the left control console.
- Refuel the excavator, if necessary (page 102).
- Close and lock the cab door. The key must remain with the operator.
- Check the excavator for external damage and for leaks. Any defects must be repaired before the next start.
- In case of a heavy accumulation of dirt in the area of the tracks and the hinges at the front attachments, clean the excavator (page 123).

Operation

Operating the heating system (cab version)

- Open the engine compartment cover (page 106).
- Open heater valve (1) by turning against the clock.



The heater valve should be always closed in summer.

- Close the engine compartment cover.



All activities described below and required for operating running.



To avoid accumulated heat and damage to the ventilation system, do not cover air nozzles with objects (e.g. bags or clothes) when the heater is on.

- Start the engine (page 67).
- Set the blower switch to position LO or HI.

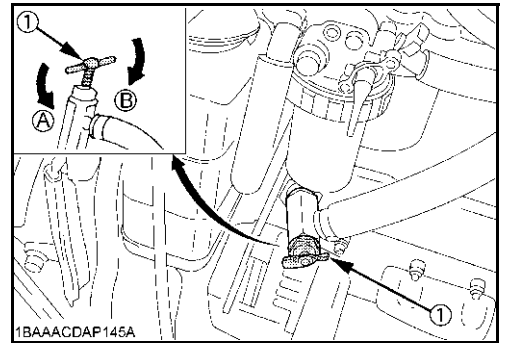

- To heat the cab faster, switch aerial supply to position circulating air (2) with lever (1).

No cold outside air will follow and the circulating inside air heats faster.

So that the windows do not steam up at longer operation of the heater, the aerial supply should be switched back to position "fresh air" (3) after the warm-up phase of the cab is complete.



In dusty surroundings, the fresh air supply should be switched on in order to increase the air pressure inside the cab. This contributes to the fact that no dust penetrates into the cab.

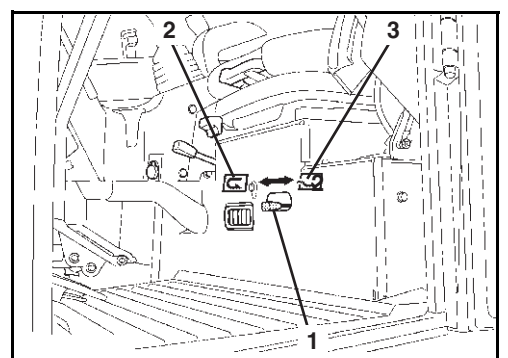
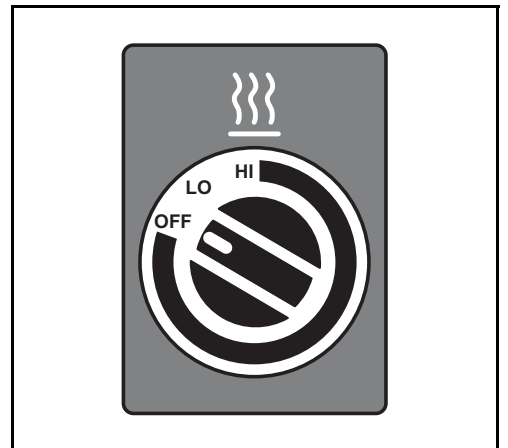



Lasting circulating air mode leads to overtiring of the operator! Circulating air mode for a longer period of time can lead to lack of oxygen and overheating inside the cab. No cool fresh air flows in from the outside. The operator therefore overtires quickly.

With operation-warm engine, the heater air flows out of the air nozzles (1).

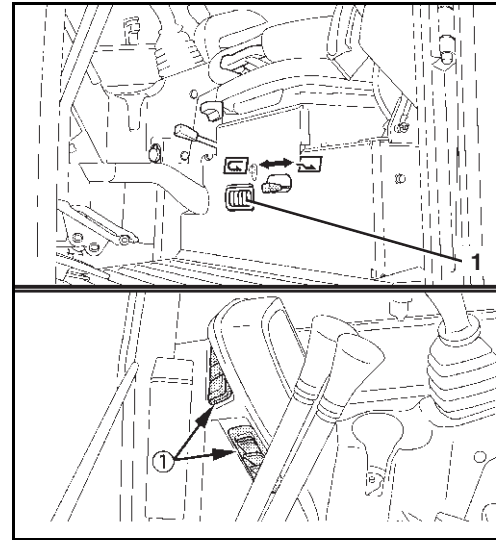

Operating the wiper/washer system (cab version)

All cab models are equipped with a wiper/washer system.



Risk of injury!

If you turn on the wiper while the windscreen is opened, the wiper may slide off the mounting bracket attached to the cab frame hitting the inside of the cab. there is a risk of the operator's face being hit by the wiper.

- Do not turn on the wiper switch while the windscreen is open.

Switching on the windscreen wiper

- The starter switch is in the RUN position.
- Press the switch (1) to the WIPER/WASHER position.

The wiper operates as long as the switch remains in this position.

- To switch off, press the switch (1) to the OFF position.

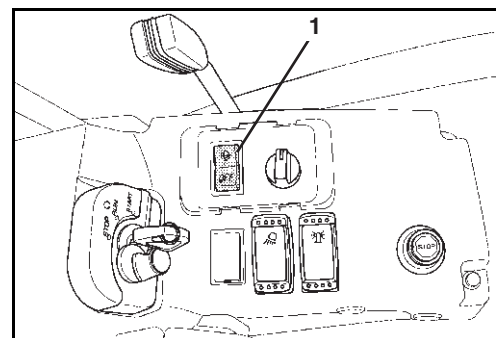

In extremely cold weather conditions, make sure the wiper rubber does not stick to the window. This can damage the wiper rubber or the wiper motor.



Only switch on the wiper when the window glass is wet. If necessary, switch on the washer system first.

Operation

To turn on the washer system

The washer system can be operated irrespective of whether the wiper is on or off.

If the wiper is on:

- Press the switch (1) to the WIPER/WASHER position again and hold it down.

If the wiper is off:

- Press the switch (1) to the OFF position and hold it down.

The washer system runs for as long as the switch is held down.

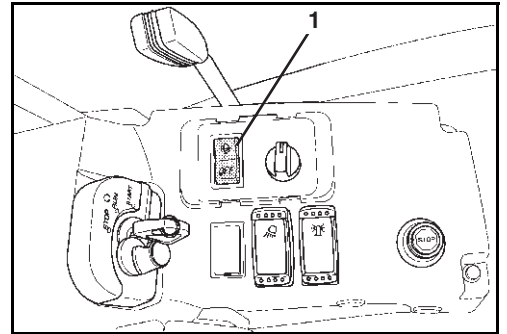

Do not operate the washer system if its reservoir is empty as running dry could damage the pump.

Operating the interior light (cab version)

- The starter switch is in the RUN position.
- Press the switch (2) to the ON position.

The interior light (1) is illuminated as long as the switch remains in this position.

- To switch off, press the switch (2) to the OFF position.

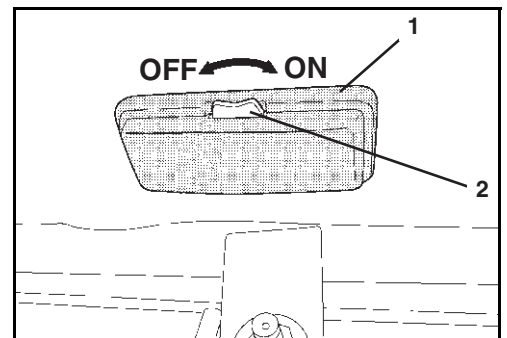

Operating the rotary beacon (accessories)

- The starter switch is in the RUN position.
- Press the rotary beacon switch (1) to the ON position.

The rotary beacon operates as long as the switch remains in this position.

- To switch off the rotary beacon, press the switch to the OFF position.

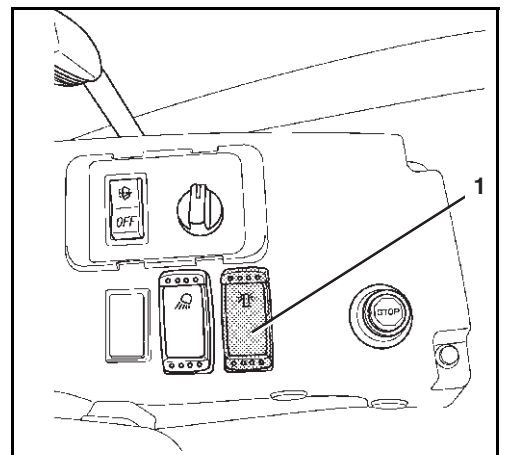

Operating the 12 V plug

- Open the cover cap (1) and put the load into the 12 V plug.



The rated current of the connected load must not exceed 10 A.

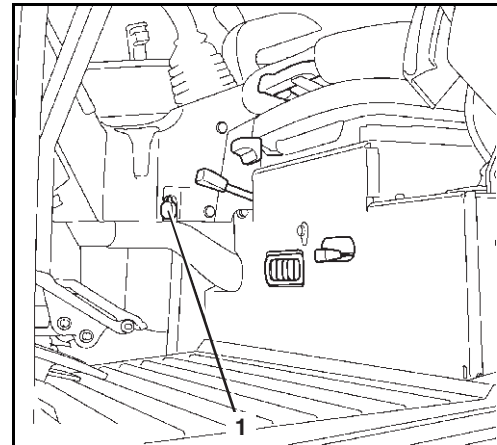

Opening and closing the cab door (cab version)

Opening the cab door from outside

- Unlock the cab door at the door lock (3).
- Open the cab door by pulling at the door handle (1) and lock the door by attaching the hook (2) at the cab wall.

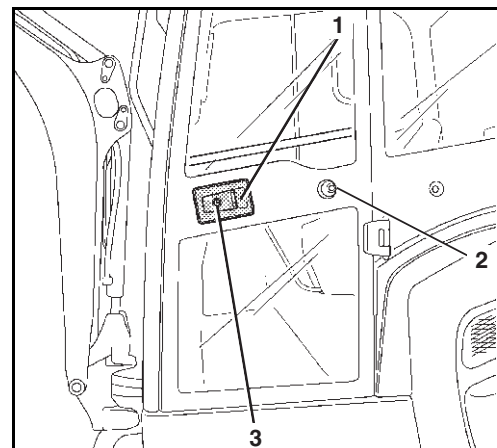

Closing the cab door

- Pull out release lever (1) and pull cab door shut until it latches.

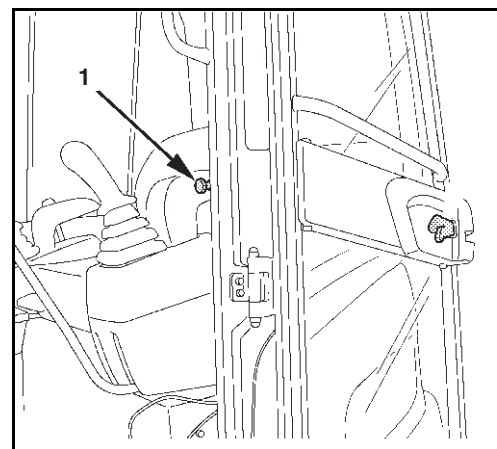

Operation

Opening the cab door from the inside

- Pull the release lever (1) and open the door. If the cab door is not closed again right away, lock the door at the cab wall.

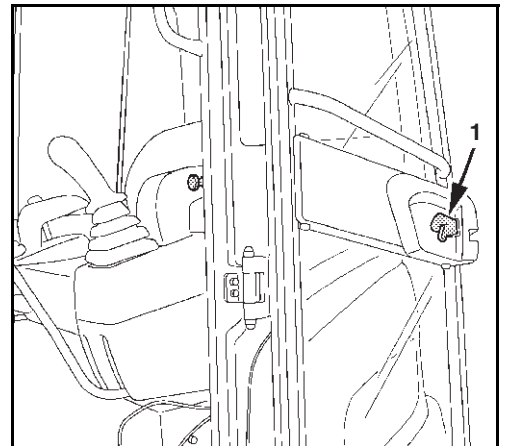

Opening and closing the windows (cab version)

Front window



Always lock the front window. Do not stay in the cab and operate the excavator with the front window unlocked. When opening the window, always keep both hands on the grips (2) to prevent injury by pinching or crushing.



The front window is opened and closed from the operator's seat.

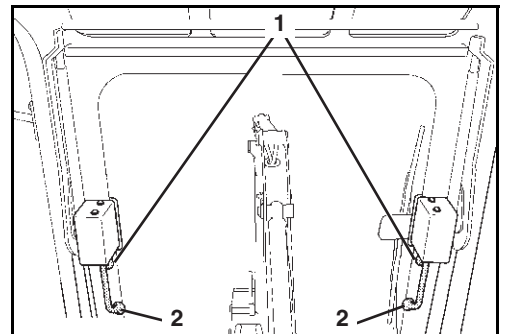

Opening

- Press the right and left lock bars (figure above/1) inwards simultaneously and push the front window upward at both grips (figure above/2) in the guide rails as far as the stopper. Lock the front window at the endpoint. Check that the front window is locked.



Do not release the handles when raising the window as the front window could suddenly rise in an uncontrolled way and strike the operator's head. Please follow the safety instructions on the side window.

Closing

- Press the right and left lock bars (figure above/1) simultaneously and, using both grips (figure above/2), push the front window forward within the guide rails up to the stopper. Lock the front window at the stopper by releasing the lock bars. Check that the front window is locked.

Side window

- Pull the grip (1) to release the lock and pull side window open to the rear or to the front.
- To close the side window, slide it forward or backward until the lock snaps in at the window frame.

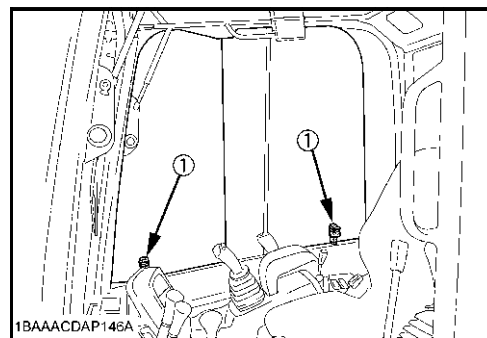

Operating the working lights (optional for KX015-4/KX016-4)

- The starter switch is in the RUN position.
- Press the working light button (1) to the ON position. The working lights on the cab are turned on.
- To switch off the working lights on the cab, press the button to the OFF position.



During work on public roads other road users must not be blinded.

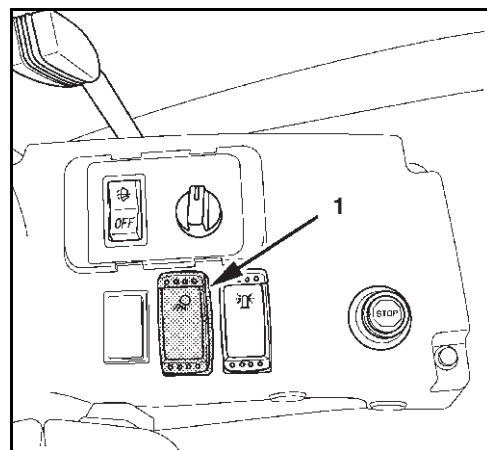

Cold weather operation

Operating the excavator at an ambient temperature below 5 °C is regarded as cold weather operation.

Necessary preparations prior to the winter season

- If necessary, replace the engine oil and hydraulic oil with those of the viscosities specified for winter.
- Only use regular diesel fuel with winter additives. Do not mix petrol and diesel fuel.
- Check the battery's state of charge. In case of extremely low temperatures, it may be necessary to remove the battery after work and store it in a heated room.
- Check the antifreeze strength in the cooling system (page 123). If necessary, add antifreeze until the protection ranges from -25 °C to -40 °C.
- Apply talcum powder or silicone oil to all rubber seals at the windows, the cab door and the side window guide rails.
- Lubricate all locks, except the starter switch, with graphite lubricant.
- Grease the cab door hinges.
- Fill the washer system with a antifreeze window cleaner (page 102).

Operation during the winter season

- The excavator must be cleaned after work is finished (page 123); Special attention must be paid to the crawlers, the front attachments and the piston rods of the hydraulic cylinders. If the excavator is cleaned with a water jet, it must then be parked in a dry, frost-free and well-ventilated enclosed space.
- If necessary, park the excavator on boards or mats in order to prevent freezing to the ground.
- Before starting, check if the piston rods of the hydraulic cylinders are free of ice to avoid damage. Also check if the crawlers are frozen to the ground. If so, do not take the excavator into operation.



Be careful when getting on and off, the crawler could be slippery.

- Start the engine (page 67) and let it run at idle speed until the engine has accommodated to the outside temperature. Before you start working with the front attachments, warm up the excavator until the operating temperature is reached.

Jump-starting the excavator



Only a vehicle or starting device with a 12 V power supply may be used.



The operator must remain seated on the operator's place, the battery jumper cables must be connected by a second person.

- Make the battery accessible, and remove the positive terminal cover.
- Position the other vehicle or starting machine beside the excavator.



Only use cables with an appropriate cross section as jumper cables.

- Connect the positive terminal of the excavator battery with the positive terminal of the helping vehicle (see figure).
- Connect the negative terminal of the helping vehicle to the frame of the excavator. Do not use the negative terminal of the excavator battery. The connecting point on the frame must be blank and clean.

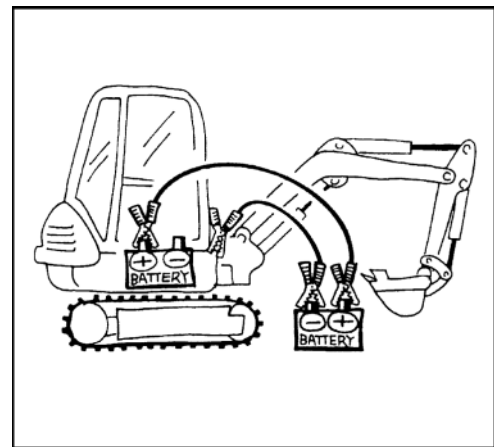

- Start the helping vehicle and let it run at a higher idle speed.
- Start the engine (page 67) and let it run at idle speed. Check if the charge lamp turns off after starting.
- Disconnect the jumper cable at the frame of the excavator first, and then at the negative terminal of the helping vehicle.
- Disconnect the second jumper cable from the positive terminal of the excavator battery first, and then from the positive terminal of the helping vehicle.
- Place the positive terminal cover onto the excavator battery.
- If the jumper cables will be required for the next start of the excavator, check the battery and the alternator's charging circuit, contact skilled personnel, if necessary.

Operating in emergency situations

In case of emergency, you can switch off the engine and lower the boom manually.

Engine stop knob

If the engine cannot be stopped with the key, it can be stopped manually.

- To stop the engine, pull the knob (1) until the engine stops.
- After the engine has stopped, push in the knob.

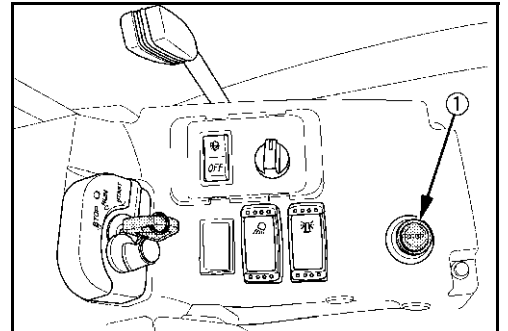

The excavator may only be taken back into operation after the malfunction has been eliminated.

Manual lowering of the front attachments

The boom and arm can be lowered in case of an engine failure or if malfunctions occur in the hydraulic system.

- The starter switch is in the RUN position.
- If necessary, lower the boom and the arm with the control levers as described in the "Operating the controls during excavation work" section (page 77).



Make sure nobody is standing in the lowering area before starting the emergency lowering procedure.



The lowering function is available only for a short time, as it is controlled by the accumulator in the hydraulic system. The cylinders extend or retract by force of gravity.

Filling up the washer system

- Open the cap (1) of the washer system reservoir (2) and add water or a cleaning agent.



In winter, use a cleaning agent with antifreeze.

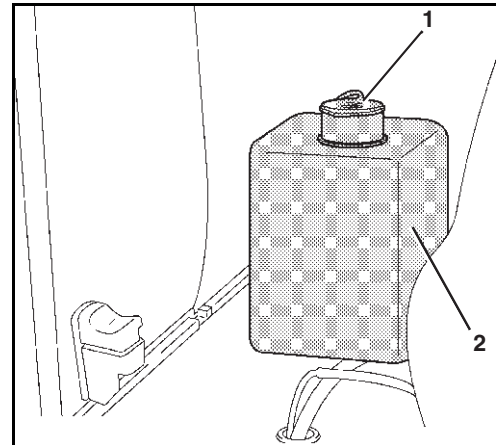

Refuelling the excavator



When refuelling the excavator, smoking, an open flame, or other sources of ignition are not allowed. The danger zone has to be clearly marked with signs. A fire extinguisher must be kept at hand in the danger zone.



Spilled fuel must be bound immediately with an oil binding agent. The contaminated oil binding agent must be disposed of in accordance with the applicable environmental regulations.



If no pumping station is available, the diesel fuel may only be stored in approved canisters.



Refuel the excavator in time so that the fuel tank is not running empty. Air in the fuel system can damage the fuel injection pump.

- Stop the engine.
- Insert the ignition key in the lock (1) of the filler cap (2) and turn it anti-clockwise.
- Open the filler cap by turning it anticlockwise.

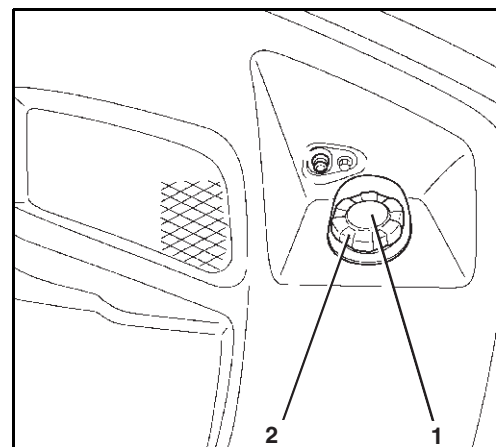

Operation

- Insert filler funnel (1) in filler neck (2) start and turn clockwise, until the funnel engages.
- Fill diesel fuel up to the base of the filler neck.
- Screw on the fuel cap and turn the ignition key clockwise to lock the fuel cap.

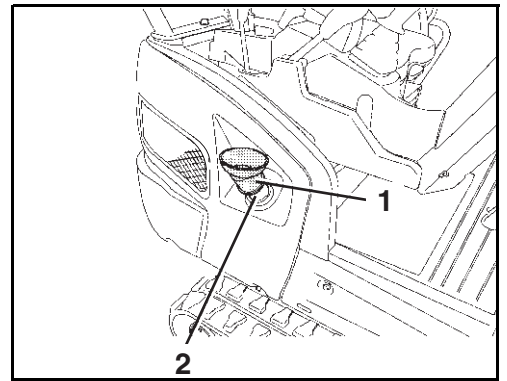

Fill level monitor when refuelling

The momentary fill level during refuelling can be determined by means of an acoustic signal.

The switch for the fill level monitor (1) is located above the tank filler neck (2).

- Press switch (1) to activate fill level monitoring.

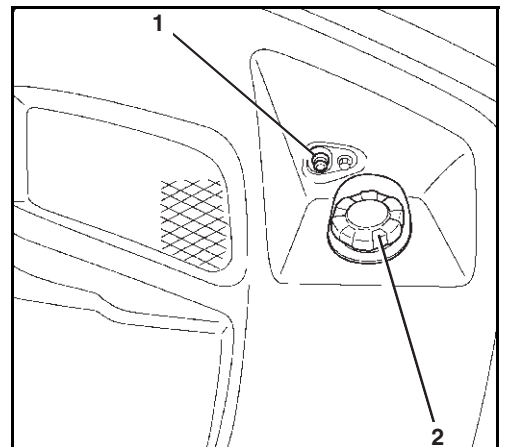

The following signals are output:

Interrupted signal	→ Tank is empty
Periodic signal	→ Tank is being filled
Continuous signal	→ Tank is full



The signal breaks off completely if the flow rate is too low. As soon as there is enough fuel in the tank, the signal restarts.

Press switch (1) after refuelling to deactivate fill level monitoring.

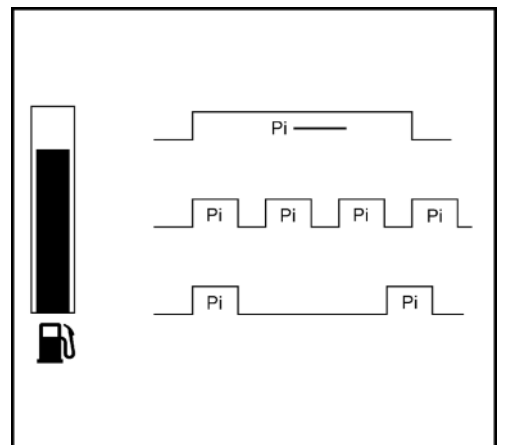

Bleeding the fuel system



If the excavator fuel tank was run empty or the water separator was cleaned, the fuel system must be bled.

- To bleed the fuel system, move the starter switch to the RUN position. The electrical fuel pump will bleed the fuel system automatically within approx. 60 s.
- If the bleeding was insufficient, the engine will stop again. In this case repeat the procedure.

Replacing the fuses



Defective fuses may only be replaced with fuses of the same type and same rating.



The bypassing of fuses, for example by a wire, is not allowed.



If the malfunction can not be remedied by replacing the fuse, or if the fuse blows again when starting, contact skilled personnel.



The main fuses (page 105) of the excavator are situated above the battery.

- Open the cover (1) by unlocking (2) and lowering it.

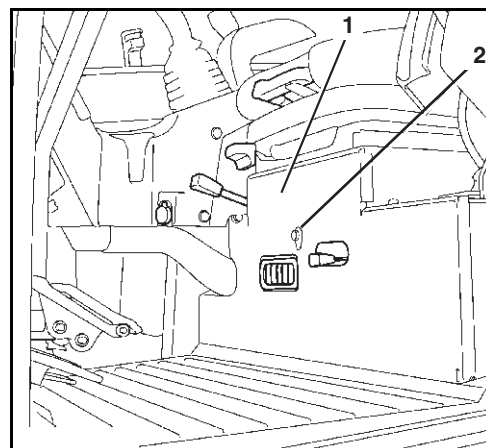

- Remove the defective fuse from the fuse box (1) and replace it.
- The fuse layout is shown in the figure below.

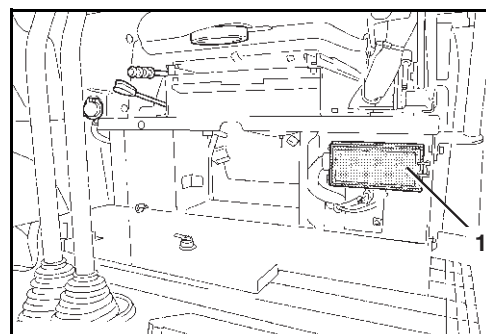

Fuse layout of the fuse box

20	21	22		1	2	3	4		5	6		7		8	9	10
5 A	10 A	15 A		5 A	5 A	5 A	10 A		5 A	10 A		5 A		15 A	15 A	10 A
	30 A			10 A	15 A	15 A	15 A		30 A					5 A	10 A	5 A
19				18	17	16	15		14					13	12	11

1	Starter	5 A	12	Horn switch	10 A
2	Control lever lock	5 A	13	Control unit	5 A
3	Fuel pump	5 A	14	Engine cut-off switch	30 A
4	Control unit (AC)	10 A	15	12-V socket	15 A
5	Relay supply circuit	5 A	16	Wiper/washer system	15 A
6	Alternator	10 A	17	Radio (AC)	15 A
7	Interior lighting	5 A	18	Fan motor	10 A
8	Rotary beacon	15 A	19	Spare fuse	30 A
9	Working lights	15 A	20	Spare fuse	5 A
10	Horn	10 A	21	Spare fuse	10 A
11	Display and control unit	5 A	22	Spare fuse	15 A

Main fuses

- Take out defective main fuse and replace.

Fuse layout:

- 1 → Main fuse (50 A)
- 2 → Main fuse (60 A)
- 3 → Fuse (10 A)

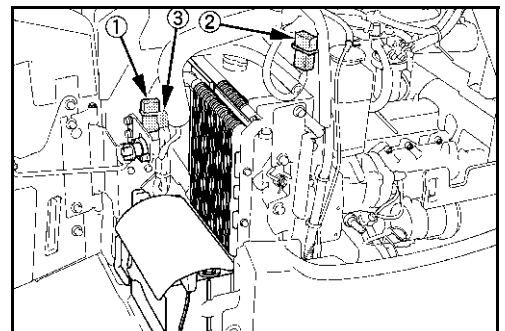

Operating the battery cut-off switch

In order for the excavator to be operated, the battery cut-off switch (1) must be in the ON position.

A → OFF
B → ON



If the battery cut-off switch is in the OFF position, most of the electrically powered functions will also be switched off (e.g. horn, fuel fill level monitor, etc.).



The user settings for the display and control unit are saved, and the battery discharges itself only minimally.

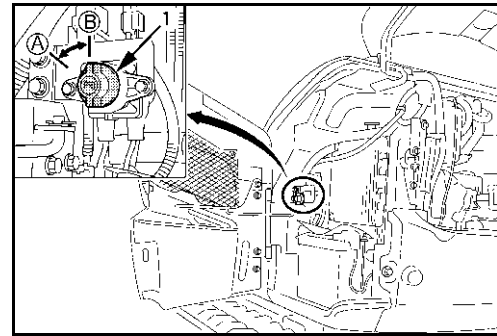

Opening and closing the engine compartment cover



*Risk of injury by engine compartment cover swinging upwards!
Putting up the engine compartment cover is supported by a gas spring. The engine compartment cover can suddenly swing upwards when opening it!
Always hold on to the engine compartment cover while opening it and move it upwards slowly.*

- Insert the key in the lock (1) of the engine compartment cover (3) and turn it clockwise.
- Pull the handle (2) and swing the engine compartment cover completely upwards.

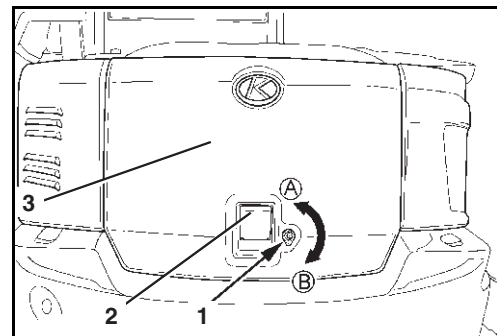

The engine compartment cover is supported by a gas spring that keeps it up once it is open.



Pay attention to the fact that the gas spring holds the engine compartment cover up safely. If the engine cover is unexpectedly slammed shut, for example by another person or by the wind, serious injury could result.

- For closing the engine compartment cover, pull it down and into the lock.
- Turn the key anticlockwise to lock the engine compartment cover.
- Pull out the key.

Opening/closing the side cover

- Open the engine compartment cover (page 106).
- In order to release the side cover (2) turn the lock (1) clockwise.
- Swing side cover (2) aside until the locking device (3) engages.



Make sure that the catch has snapped into place properly. If the engine cover is unexpectedly slammed shut, for example by another person or by the wind, serious injury could result.

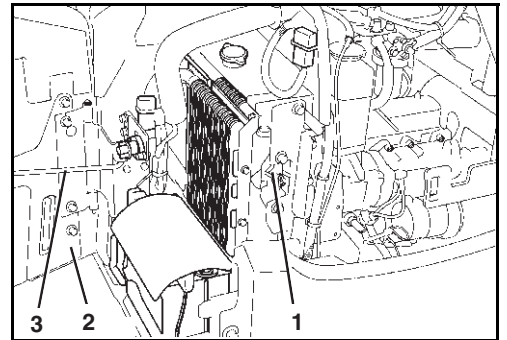

- For closing, pull the locking device (3) from the catch.
- Close the side cover (2) and press into the lock (1).



Make sure that the lock has properly engaged.

- Close the engine compartment cover.

Replacing the bucket



When replacing the bucket, make sure to wear an eye protection, a helmet and protective gloves.



During attaching and detaching, chippings and burrs may occur at the bolts or bushings. These may cause severe injuries.



Never use your fingers for the alignment of the components (linkage, bucket, arm). The components may sever your fingers by uncontrolled movements.

Anti-theft system

The excavator is equipped with an anti-theft system that restricts the engine to be started using a registered key only. If a registered key gets lost or stolen, you can invalidate it. This will prevent the engine from being started with this key, thus protecting the vehicle against theft. The anti-theft system makes it difficult to steal the machine. However, it can not fully prevent theft.

If the starter switch is set to STOP, the indicator light (1) is illuminated, indicating the activation of the anti-theft system.

Make sure that the indicator light is illuminated when leaving the machine.

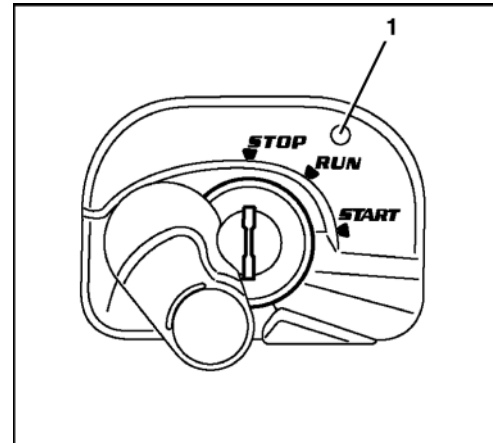

The vehicle comes with two different types of keys:

Black (individual) key

- This key is used to start the engine.
- The engine can be started by inserting the key and turning it to the START position.
- To be able to start the engine with a black key, it must be registered using the red key.

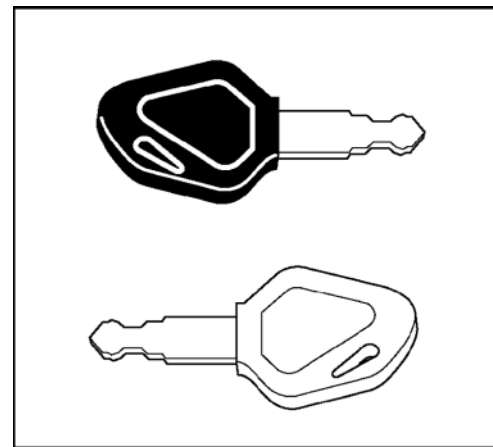

The engine can be started only with a key that was registered for the particular vehicle. The scope of delivery includes two black keys, among them a spare key. The two black keys have already been registered. Up to four keys can be registered.

Red key (for registering)

- If one of the black keys is lost, another black key can be registered using the red key (page 110).
- The engine can not be started with the red key.

The key system

- If a registered key is lost, the second and new black key must be re-registered. This procedure locks the lost or stolen black key, which can no longer be used to start the engine.
- If the red key is lost, the black keys can no longer be re-registered. Be sure to keep the red key in a secure location (such as a safe in the office). Never leave the key inside the machine. If it should get lost nevertheless, please contact your authorised dealer immediately.
- If six times attempts are made within one minute to turn the starter switch to the START position with a wrong or unregistered key, an acoustic signal will sound for 30 seconds. The signal will continue to sound even if the starter switch is turned to the STOP position again or the key is removed within this time period. When a key registered for this machine is inserted into the starter switch, the acoustic signal will be turned off.
- Do not use several of these keys in a bunch. This could lead to electrical interfering frequencies which might prevent the motor from starting.
- Use only the special KUBOTA key ring. Other key rings can lead to signal failures between the key and starter switch, and the engine can possibly not start or a key registration cannot be performed.
- After receiving the set of keys, separate them from each other. Always make sure the keys are not part of a bunch. If one of the black keys, for example, is inserted into the starter switch, the red key might be detected by the electronic system. This might lead to a failure of the electronic system.
- If machine malfunctions occur, please contact your Kubota dealer immediately in order to have the malfunction localised and remedied.

Registering a black key for the machine



Register a black key only under the following conditions:

Make sure that there are no persons within the excavator's working area. It is essential to warn persons in the vicinity of the excavator by briefly honking the horn.

Make sure that all operational controls are in the neutral position.

Starting the excavator is only allowed when the operator is sitting on the operator's seat.

Do not allow the engine to run indoors, unless the room is equipped with an exhaust gas extraction system or otherwise well ventilated. The exhaust gas contains carbon monoxide, a colourless, odourless, and lethal gas.

1. Insert red key into the starter switch.



Do not turn the key at this point. If the key is in the RUN position, turn it back to the STOP position.

2. Press the display selector switch.
3. The indicator Pull out key blinks.

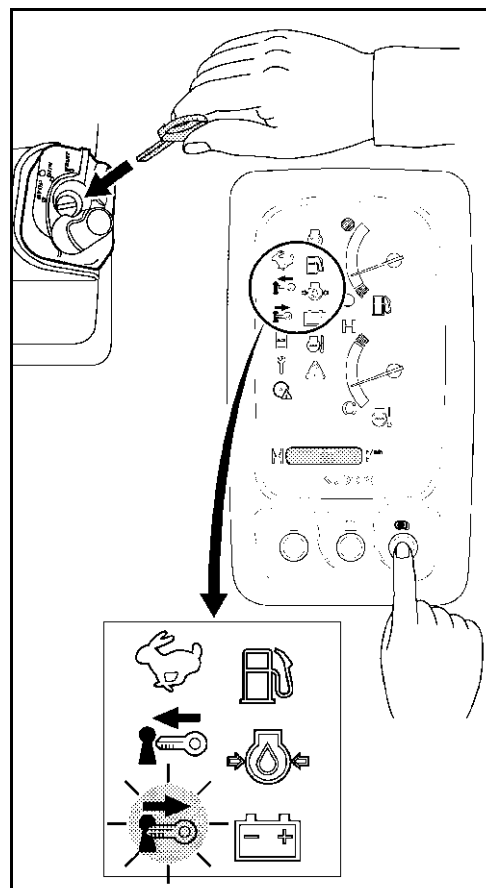

Operation

4. Pull out the red key.
5. The indicator Insert key blinks.
6. Insert black key into the starter switch.



Do not turn the key at this point. If the key is in the RUN position, turn it back to the STOP position.

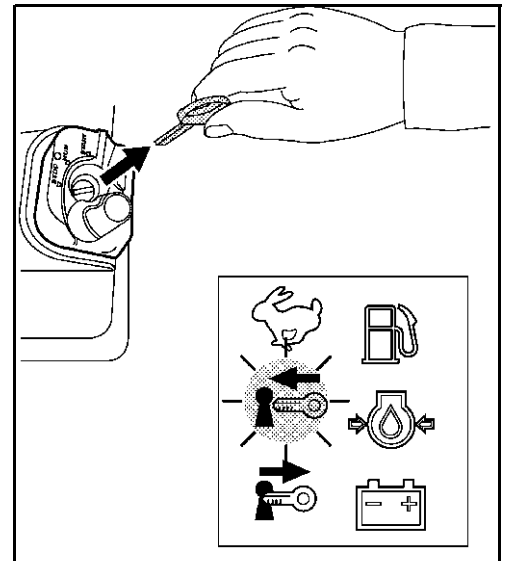

7. After a short moment, the indicator Pull out key blinks. This points out the fact that the black key has been registered for this vehicle.

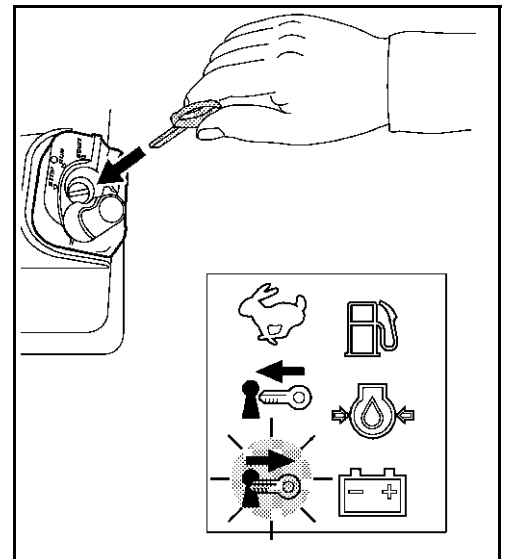

8. Turn key into position RUN to complete the registration process.
9. One after the other, insert all registered black keys into the starter switch and check whether the engine can be started using these keys.



If a registered black key is lost, the other black keys must be re-registered. This procedure locks the lost or stolen black key, which can no longer be used to start the engine.

Troubleshooting

The troubleshooting section includes only malfunctions and incorrect operations which must be remedied by the operator. Any other malfunctions may only be eliminated by trained personnel. The troubleshooting must be performed with the aid of the troubleshooting table. In order to locate a malfunction, first look in the MALFUNCTION column for the corresponding excavator malfunction. In the POSSIBLE CAUSE column you will find the possible causes for the malfunction. The REPAIR column indicates the required remedial measure. If the fault can not be remedied by the measure indicated in the REPAIR column, consult trained personnel.

Safety rules for troubleshooting

Adhere to the general safety rules (page 13 and the safety rules for operation (page 57).

The operator is not allowed to open the electrical and hydraulic system. These services are reserved for trained personnel.

During troubleshooting, the safety on and around the excavator must always be ensured.

If troubleshooting of the excavator calls for the bucket being raised, the operator may not stand in the area of the front attachments unless the front attachments are secured against inadvertent lowering by suitable measures.

Troubleshooting: Before operation

MALFUNCTION	POSSIBLE CAUSE	REPAIR
Start-up		
No function available when the starter switch is turned to the RUN position	Main fuse at battery defective	Replace the main fuse (page 105).
Indicator lights do not come on as expected when the starter switch is turned to the RUN position	Defective fuse	Replace the fuses (page 104).
Starter does not turn when the starter switch is turned to the START position	Battery depleted	Charge the battery (page 134). Jump-starting the excavator (page 100).
	Engine stop knob pulled	Push the engine stop knob (page 25).
	Control lever lock not raised	Raise the control lever lock.
Engine does not start when the starter switch is turned to the START position, but starter turns	Air in the fuel system	Check the fuel system for leaks and bleed it (page 103).
	Water in the fuel system	Check the water separator for water content, drain water if necessary (page 129).















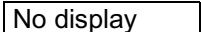

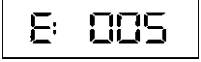

Troubleshooting: Operation

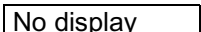

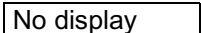



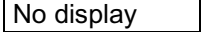



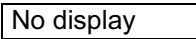

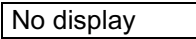

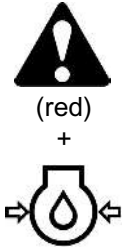
MALFUNCTION	POSSIBLE CAUSE	REPAIR
Operation		
Exhaust gas colour very black	Air filter restricted	Check, clean and replace the air filter (page 128).
Insufficient engine power	Air filter restricted	Check, clean and replace the air filter (page 128).
	Fuel filter restricted or water in fuel system	Check the water separator for water content. Drain it (page 129) and renew the fuel filter (page 129), if necessary.
Deviation in driving direction of excavator	Crawler tension adjusted incorrectly	Check and adjust the crawler tension, if necessary (page 138).
No pilot-controlled hydraulic functions available	Fuse in fuse box defective	Replace the fuses (page 104).
Power of hydraulic functions is too low or disruptive	Hydraulic oil level too low	Check the hydraulic oil level, add hydraulic oil (page 132).
	Suction filter restricted	Change the suction filter in the hydraulic oil tank (page 131).
Travel speed button does not work	Fuse in fuse box defective	Replace the fuses (page 104).
Heater fan, wiper/washer system, interior light, horn, working light not operating	Fuse in fuse box defective	Replace the fuses (page 104).



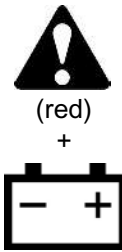



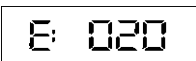

Troubleshooting: Display indications

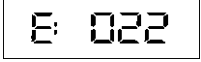

If the machine develops a fault, one of the following messages will appear on the display. In the event of problems please inform your KUBOTA dealer immediately.

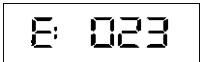
No.	Display	Indicator	Problem/Error	Preliminary Measure	Solution
1.	CAN System Error 		The Controller Area Network (CAN) has developed a fault. Measured values may be incorrect and switches may not function.	The machine can be started and driven. Do not perform any work with the machine.	Inform your KUBOTA dealer immediately.
2.	Feed fuel 		This message appears when the fuel level is low and prompts the operator to refuel.	-	Refuel the excavator.
3.	Periodic check soon (notice) 		This message means that the regular service is due shortly.	Operate the machine as usual.	Ask your KUBOTA dealer about the relevant parts. Run the maintenance procedure.
4.	Period check passed (warning) 		This message means that the regular service is due.	The machine can be operated but service must be carried out urgently.	Ask your KUBOTA dealer about the relevant parts. Run the maintenance procedure.
5.	Water temperature raising 		The temperature of the coolant is higher than normal.	Operate the machine only with reduced loads until the temperature is normal again.	-
6.	-	-	-	-	-
7.	Wrong key, unable to start 		The machine cannot be started because the wrong key has been inserted.	Use the correct key.	-
8.	RED registration key, unable to start 		Try starting the engine with the red key (for registration).	Use the correct key.	-
9.	Clock setting request 		Power was interrupted and the clock now has to be set again.	To adjust the clock, press the display selector switch.	-
10.	-	-	-	-	-
11.	Raise the control lever lock 	 (yellow)	This message indicates a step in a procedure.	Raise the control lever lock; the indicator goes out.	-

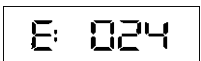
No.	Display	Indicator	Problem/Error	Preliminary Measure	Solution
12.	Pull out Key 		The key must be pulled out.	Pull out Key.	-
13.	Lower the control lever lock 	 (yellow)	This message indicates a step in a procedure.	Lower the control lever lock; the indicator goes out.	-
14.	Oil pressure too low 	 (red) +	The engine oil pressure is too low.	Stop the engine immediately. The engine may have developed a fault.	Inform your KUBOTA dealer immediately.
15.	Overheat 		The machine is overheated and must cool off by idling.	Allow the machine to cool off by idling. Do not switch the engine off as the coolant could then boil over.	Clean the radiator and check the coolant, top up if necessary. Check the hydraulic system for leaks; if necessary, inform your KUBOTA dealer.
16.	Charging system error 	 (red) +	The charging system has developed a fault.	Check the V-belt. When the V-belt is OK, let the engine run until indicator goes out.	If the indicator does not go out, inform your KUBOTA dealer immediately.
17.	Fuel sensor error 	 (red)	The fuel sensor has developed a fault; the fuel gauge does not appear in the display.	Press the display selector switch to return to the default display.	Inform your KUBOTA dealer immediately.
18.	Water temperature sensor error 	 (red)	The coolant temperature sensor has developed a fault; the coolant temperature gauge does not appear in the display.	Press the display selector switch to return to the default display. The functions of the machine are stable but overheating cannot be excluded.	Inform your KUBOTA dealer immediately.
19.	-	-	-	-	-
20.	Lever lock system error 	 (red)	The electrical system in the control lever lock has developed a fault.	The engine can be started but the machine cannot be set in motion.	Inform your KUBOTA dealer immediately.

No.	Display	Indicator	Problem/Error	Preliminary Measure	Solution
21.	Travel speed system error 	 (red)	The electrical system in the travel speed has developed a fault.	The machine can only be set in motion at low speed.	Inform your KUBOTA dealer immediately.
22.	Versatile operating switch system error 	 (red)	The multifunctional switch has developed a system fault.	The machine can be operated but the auxiliary port will not function.	Inform your KUBOTA dealer immediately.
23.	Auxiliary port 1 system error 	 (red)	Auxiliary port 1 has developed a fault.	The machine can be operated but auxiliary port 1 will not function.	Inform your KUBOTA dealer immediately.
24.	Auxiliary port 2 system error 	 (red)	Auxiliary port 2 has developed a fault.	The machine can be operated but auxiliary port 2 will not function.	Inform your KUBOTA dealer immediately.

Maintenance

The "Maintenance" section includes all care and maintenance tasks to be performed on the excavator.

A careful maintenance of the excavator will guarantee functional safety and longer service life.

Neglect of the servicing will void the warranty and any liability by KUBOTA.

Only use spare parts that are recommended by the manufacturer. Non-approved spare parts of inferior quality or wrong classification result in an increased risk of accidents. Operators using non-approved spare parts are fully responsible for any damage arising thereof.

Safety rules for maintenance

- Persons who work with or on the excavator must be provided by the operator with, and where applicable use suitable personal protective equipment (PPE), for example suitable working clothes, safety shoes, safety helmets, eye protection, ear protection and air-filter masks. The owner/employer bears the main responsibility for the PPE, which is specified by the safety rules for particular types of activity.
- Maintenance, cleaning and care activities may only be carried out if the excavator is fully shut down. the excavator must be secured against starting by removal of the key. The bucket must always be lowered to the ground for servicing.
- The bucket must always be lowered to the ground for servicing.
- When defects are detected during servicing or maintenance, the excavator may only be operated after the defects are remedied. Repairs may only be carried out by trained personnel.
- When carrying out maintenance and care activities, always make sure that the excavator is secured and stable.
- When working on the fuel system, smoking, open flames and the operation of other ignition sources are not allowed. The danger zone has to be clearly marked with signs. A fire extinguisher must be kept at hand in the danger zone.
- All waste materials must be discarded in accordance with environmental protection regulations.
- Use the maintenance and care materials listed in the "Recommended lubricants" section (page 145).
- When working on the electrical system, disconnect it from the voltage source before starting the work. The work may only be carried out by technicians with electrical training.
- Always use a ladder or a scaffold if the work cannot be reached by the operator.
- The controls may only be used while the operator is sitting on the operator's seat.

Personnel requirements

- The operator may only carry out cleaning and care activities.
- The servicing may only be performed by trained personnel.

Maintenance interval display

Already 10 hours before a certain maintenance interval is due, the respective maintenance interval is indicated in the display.

No.	Display	Maintenance point	Elapsed hours of operation							Interval
			50	100	250	500	600	750	1000	
1	C: 001	Engine oil change				○			○	500 h
2	C: 002	Hydraulic oil change							○	1000 h
3	C: 003	Replace the air filter elements							○	1000 h
4	C: 004	Replace the fuel filter				○			○	500 h
5	C: 005	Engine oil filter change				○			○	500 h
6	C: 006	Replace the drive unit oil	●			○			○	500 h
7	C: 007	Replace the return filter			●	○			○	500 h
8	C: 008	Suction filter change							○	1000 h
9	-	-								-
10	C: 010	Change the oil of the idler and track roller							○	2000 h

In addition to the indicator in the display, the maintenance indicator will light up (1).



The maintenance indicator automatically goes out after approx. 10 seconds and lights up again when the next maintenance interval has been reached. The maintenance interval indicator can only be reset by hand.

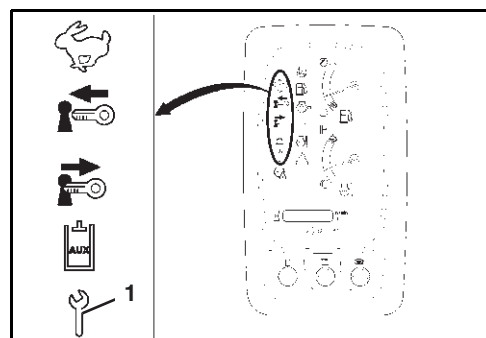

If the maintenance interval indicator has to be replaced because of a defect, the meter is set back to "0". Ask your KUBOTA dealer about this.

General maintenance chart: 50 to 500 hours of operation

Operator servicing

General maintenance	Elapsed hours of operation										Interval	Page
	50	100	150	200	250	300	350	400	450	500		
Check the fuel level											daily	64
Check the coolant level											daily	61
Checking the engine oil level											daily	60
Check the hydraulic oil level											daily	62
Grease the bucket bolt and bucket linkage bolt											daily	62
Check the V-belt											daily	61
Check the fluid level of the washer system reservoir											daily	102
Check the electric cables and connections											daily	63
Cleaning of coolant radiator and oil cooler											daily	124
Lubricate the front-end attachments	Grease the swing bracket										daily	137
	Other greasing points										daily	137
Check the water separator	○	○	○	○	○	○	○	○	○	○	50 h	129
Drain water from the fuel tank	○	○	○	○	○	○	○	○	○	○	50 h	130
Check the battery	○	○	○	○	○	○	○	○	○	○	50 h	134
Grease the swivel gear	○	○	○	○	○	○	○	○	○	○	50 h	136
Crawlers and chassis: Clean, visually inspect and check tension	○	○	○	○	○	○	○	○	○	○	50 h	138
Grease the pitch bearing				○				○			200 h	136
Check, clean the fresh air filter 1.)				○				○			200 h	140
Check, clean the air filter 1.)				○				○			200 h	128
Check the coolant hoses and hose clamps					○					○	250 h	125
Check the fuel lines and air intake hoses				○				○			200 h	130

1.) If there is a lot of dust, the air filter and the fresh air filter must be cleaned and/or replaced more often.

General maintenance chart: 550 to 1000 hours of operation

Operator servicing

General maintenance	Elapsed hours of operation										Interval	Page
	550	600	650	700	750	800	850	900	950	1000		
Check the fuel level											daily	64
Check the coolant level											daily	61
Checking the engine oil level											daily	60
Check the hydraulic oil level											daily	62
Grease the bucket bolt and bucket linkage bolt											daily	62
Check the V-belt											daily	61
Check the fluid level of the washer system reservoir											daily	102
Check the electric cables and connections											daily	63
Cleaning of coolant radiator and oil cooler											daily	124
Lubricate the front-end attachments	Grease the swing bracket										daily	137
	Other greasing points										daily	137
Check the water separator	○	○	○	○	○	○	○	○	○	○	50 h	129
Drain water from the fuel tank	○	○	○	○	○	○	○	○	○	○	50 h	130
Check the battery	○	○	○	○	○	○	○	○	○	○	50 h	134
Grease the swivel gear	○	○	○	○	○	○	○	○	○	○	50 h	136
Crawlers and chassis: Clean, visually inspect and check tension	○	○	○	○	○	○	○	○	○	○	50 h	138
Grease the pitch bearing		○				○			○		200 h	136
Check, clean the fresh air filter 1.)		○				○			○		200 h	140
Check, clean the air filter 1.)		○				○			○		200 h	128
Check the coolant hoses and hose clamps					○				○		250 h	125
Check the fuel lines and air intake hoses		○				○			○		200 h	130

1.) If there is a lot of dust, the air filter and the fresh air filter must be cleaned and/or replaced more often.

Servicing maintenance chart: 50 to 500 hours of operation

Servicing by skilled personnel or KUBOTA dealer

Servicing	Elapsed hours of operation *										Interval	Page	
	50	100	150	200	250	300	350	400	450	500			
Check the coolant hoses and hose clamps					○						○	250 h	125
Check and adjust the V-belt					○						○	250 h	125
Change the engine oil and oil filter											○	500 h	126
Replace the drive unit oil 3.)	●										○	500 h	139
Replace the fuel filter											○	500 h	129
Replace the return filter 2.)					●						○	500 h	131
Change line filter												1000 h	141
Replace the auxiliary valve filter												1000 h	142
Change the hydraulic oil and replace the suction filter 2.)												1000 h	131
Replace the air filter elements 1.)												1000 h	128
Replace the fresh air filter 1.)												1000 h	140
Change the oil of the idler and track roller	Please contact your KUBOTA dealer.										2000 h	--	
Check alternator and starter motor	Please contact your KUBOTA dealer.										2000 h	--	
Safety inspection 4.)												annually	147
Replace the coolant hoses and hose clamps	Please contact your KUBOTA dealer.										every 2 years	--	
Replace the fuel lines and air intake hoses	Please contact your KUBOTA dealer.										every 2 years	--	
Replace the coolant												every 2 years	125
Replace the hydraulic hoses	Please contact your KUBOTA dealer.										every 6 years	--	

* The servicing identified with ● must be carried after the specified hours of operation after initial operation have been reached.

- 1.) If there is a lot of dust, the air filter and the fresh air filter must be cleaned and/or replaced more often.
- 2.) When using a breaker over 20 % → every 800 h.
 When using a breaker over 40 % → every 400 h.
 When using a breaker over 60 % → every 300 h.
 When using a breaker over 80 % → every 200 h.
- 3.) Earlier if necessary.
- 4.) At least annually.

Servicing maintenance chart: 550 to 1000 hours of operation

Servicing by skilled personnel or KUBOTA dealer

Servicing	Elapsed hours of operation										Interval	Page	
	550	600	650	700	750	800	850	900	950	1000			
Check the coolant hoses and hose clamps					○						○	250 h	125
Check and adjust the V-belt					○						○	250 h	128
Change the engine oil and oil filter											○	500 h	126
Replace the drive unit oil 3.)											○	500 h	139
Replace the fuel filter											○	500 h	129
Replace the return filter 2.)											○	500 h	131
Change line filter											○	1000 h	141
Replace the auxiliary valve filter											○	1000 h	142
Change the hydraulic oil and replace the suction filter 2.)											○	1000 h	131
Replace the air filter elements 1.)											○	1000 h	128
Replace the fresh air filter 1.)											○	1000 h	140
Change the oil of the idler and track roller	Please contact your KUBOTA dealer.										2000 h	--	
Check alternator and starter motor	Please contact your KUBOTA dealer.										2000 h	--	
Safety inspection 4.)												annually	147
Replace the coolant hoses and hose clamps	Please contact your KUBOTA dealer.										every 2 years	--	
Replace the fuel lines and air intake hoses	Please contact your KUBOTA dealer.										every 2 years	--	
Replace the coolant												every 2 years	125
Replace the hydraulic hoses	Please contact your KUBOTA dealer.										every 6 years	--	

- 1.) If there is a lot of dust, the air filter and the fresh air filter must be cleaned and/or replaced more often.
- 2.) When using a breaker over 20 % → every 800 h.
 When using a breaker over 40 % → every 400 h.
 When using a breaker over 60 % → every 300 h.
 When using a breaker over 80 % → every 200 h.
- 3.) Earlier if necessary.
- 4.) At least annually.

Cleaning the excavator



Before cleaning, shut down the engine and secure it against starting.



If a steam cleaner is used for cleaning the excavator, do not direct the steam jet at electric components.



Do not direct a water jet into the intake opening of the air filter.



Do not clean the excavator with inflammable liquids.



The excavator may only be washed at suitable places (using oil and grease separators).

The excavator can be cleaned with water and a commercial cleaning agent. Make sure no water gets into the electrical system.

Use a plastic cleaner for plastic parts.

Servicing

Adhere to the instructions for regular servicing to keep the excavator in good condition.

Refilling coolant

- Open the engine compartment cover (page 106).
- Check the antifreeze content with an antifreeze tester that is qualified for -25 °C.



The antifreeze portion of the coolant should not exceed 50 %.

- Open the coolant expansion reservoir cap when the engine is cool and fill pre-mixed coolant up to the FULL mark (1).
- Close the expansion tank cover.

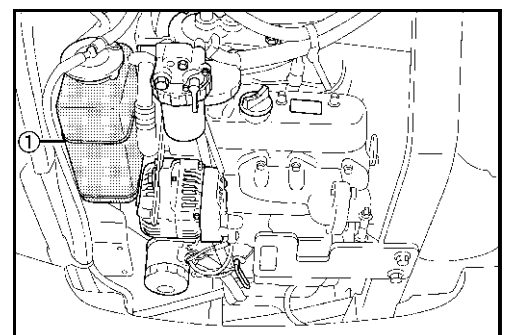

If the coolant expansion reservoir was completely empty, check the coolant level in the radiator.



Do not open the radiator cap while the engine is still hot, risk of scalding.

- Open the side cover (page 107).
- Remove the radiator cap (1) by turning it anticlockwise.
- The coolant level should be at the lower mark of the filler plug; if not, add coolant.
- Close the radiator cap.
- Close the side cover.
- Close the engine compartment cover.

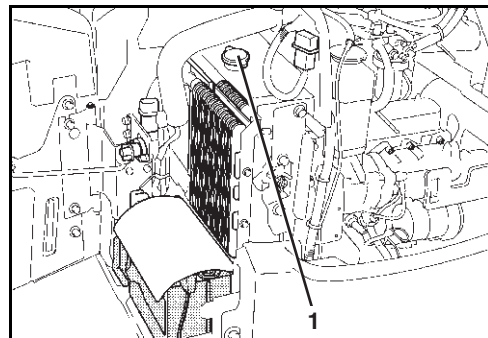

Cleaning the Coolant Radiator and the Oil Cooler



Do not touch the hot coolant radiator or oil cooler, otherwise there is a risk of burns!

- Open the engine compartment cover (page 106).
- Open the side cover (page 107).
- Clean coolant radiator (1) and oil coolers (2) from the engine with a water jet or a compressed air gun. Do not use high-pressure cleaners.
- Particular care must be devoted to the space between the radiators, because foliage often collects at this point.
- After cleaning, check coolant radiator and oil cooler for damage.
- Close the side cover.
- Close the engine compartment cover.

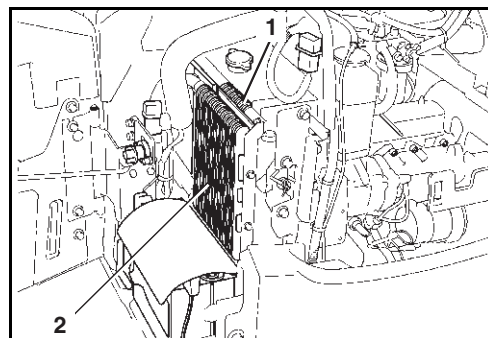

Maintenance

Checking, Adjusting and Changing the V-Belt

Adjusting the V-Belt

- Open the engine compartment cover (page 106).
- Check the V-belt (page 125).
- Remove the mounting screws (2).
- Tighten the V-belts by adjusting the tension roller (1).
- Press in the V-belt (3) at position "A". The V-belt must give way for approx. 8 mm (pressure: 10 kg).
- Tighten the fastening screws.
- After adjusting, check the V-belt.
- Close the engine compartment cover.

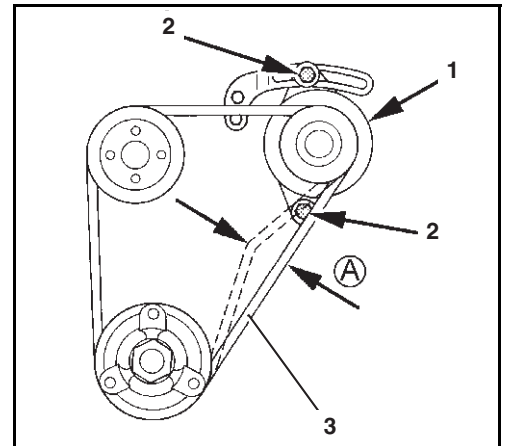

Checking the coolant hoses



Only carry out inspections when engine is cold, otherwise there is a risk of burns!

- Open the engine compartment cover (page 106).

Inspect all hose connections on the engine and to the radiator or to the heater fan (cab version) for condition (cracks, bulges, hard spots), tightness, and firm seating of the clamps. If necessary, have the hoses replaced by trained personnel.

- Close the engine compartment cover.

Replacing the coolant



Drain only when engine is cold, otherwise there is a risk of scalding!

Total cooling system capacity:	with canopy	2.7 L
	with cab	2.9 L

- Open the engine compartment and side cover (page 107).
- Remove the radiator cap (1) by turning it anticlockwise.

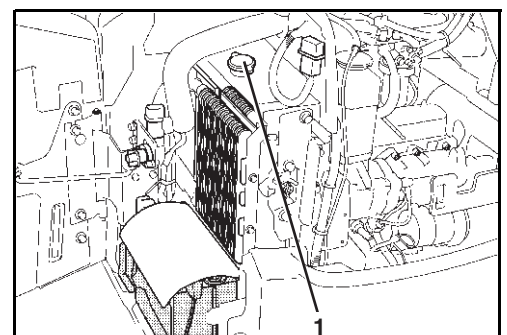

- Open the central coolant drain plug (1) and drain the coolant completely.



Fill the coolant in a container and dispose of it in accordance with the prevailing environmental protection regulations.

Purge the cooling system if the coolant is very dirty. To do this, spray water without additives into the cooling system with a hose through the filler opening until clear water emerges at the outlet.

- Close the central drain.
- Remove the coolant expansion reservoir (1) and drain it, cleaning it if necessary. Refit the reservoir.
- Fill the premixed coolant into the radiator and expansion reservoir.



Do not operate the cooling system with pure water (even in summer). The antifreeze also contains a corrosion inhibitor.

- Start the engine (page 67) and let it run at idle speed to warm up.
- Stop the engine (page 69).
- Check the coolant level (page 61), adding coolant if necessary (page 123).
- Close the engine compartment and side cover.

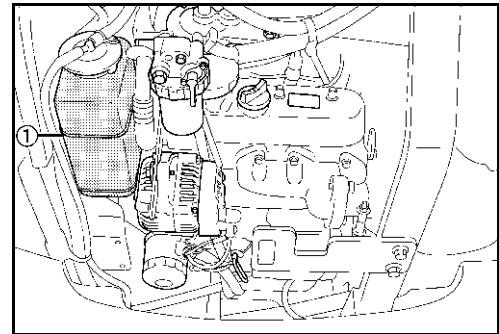
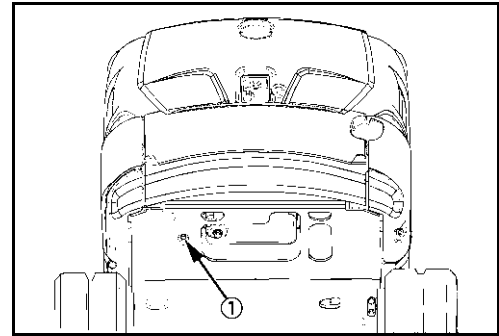

Replacing the engine oil and oil filter

- Open the engine compartment cover (page 106).



The engine oil change must be carried out while the engine is warm.



Caution: The engine oil and the oil filter are very hot → risk of scalding.



Place an oil pan with a capacity of about 15 L under the engine oil drain. The engine oil should not be allowed to seep into the soil and it must be discarded like the oil filter in accordance with the applicable environment protection regulations.

Maintenance

Draining the engine oil

- Remove the oil drain plug (1) and let the engine oil drain into the drain pan.
- Install the oil drain plug using a new seal.

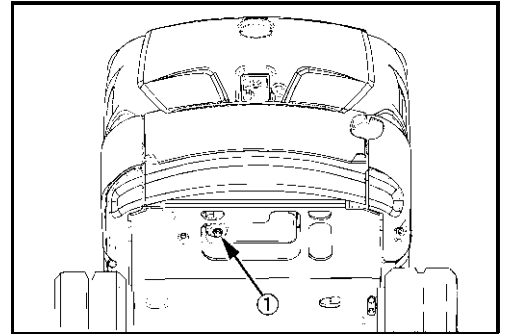

Replacing the oil filter

- Place an oil pan under the oil filter (1). Remove the oil filter using a filter wrench (turn anticlockwise).
- Coat the sealing ring of the new oil filter with engine oil.
- Install and tighten the oil filter by hand. Do not use the filter wrench.

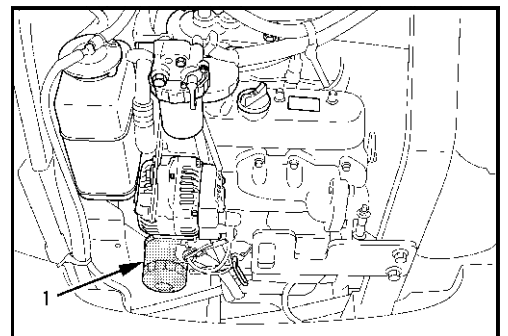

Filling the engine oil

Filling capacity: 3.6 L

- Remove the oil filler cap (2) and fill engine oil. See the "Recommended lubricants" section (page 145).
- Screw in the oil filler cap.
- Start the engine (page 67). The engine oil pressure indicator must go out as soon as the engine has started. If this does not happen, switch the engine off immediately and contact trained personnel.
- Let the engine run at idle speed to warm up, then stop it (page 69). Check the oil level after 5 minutes.
- Pull out the oil dipstick (1) and wipe it with a clean cloth.
- Insert the oil dipstick completely and pull it out again. The oil level should be in the "A" area. If the oil level is too low, add engine oil.

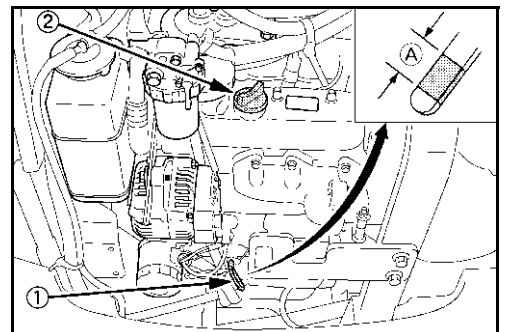

When the oil level is too high or too low, the engine might get damaged during operation.

- When changing the engine oil, fill engine oil up to the MAX mark.
- Close the engine compartment cover.

Checking, cleaning and replacing the air filter



If the excavator is operated in a particularly dusty environment, the air filter must be checked more often.

- Open the engine compartment cover (page 106).
- Open the clips (2) and remove the cover (1).
- Pull the outer filter element (1) out of the air filter case (3) and check it for dirt.
- Clean the air filter case and cover without removing the inner filter element (2). Remove the inner filter element only when replacing it.
- Replace the outer filter element if it is damaged or too much dust has accumulated on it.

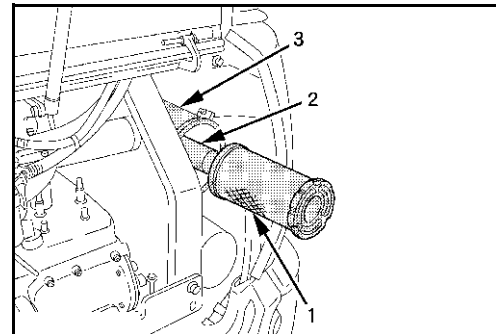
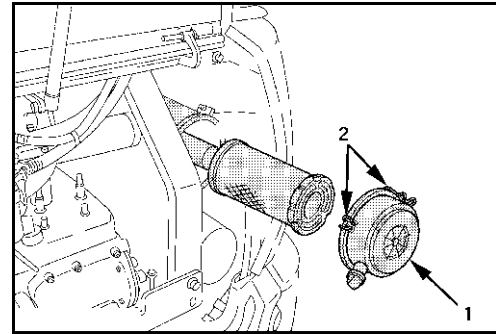

Do not clean the filter element with fluids. Never operate the engine without the air filter elements.



Always wear eye protection when working with compressed air.

- Clean the outer filter element with compressed air (max. 5 bar) from the inside out without damaging the filter element. Wear eye protection for this service.
- Insert the outer air filter element and the cover with the TOP mark up. Then lock the braces.
- Close the engine compartment cover.

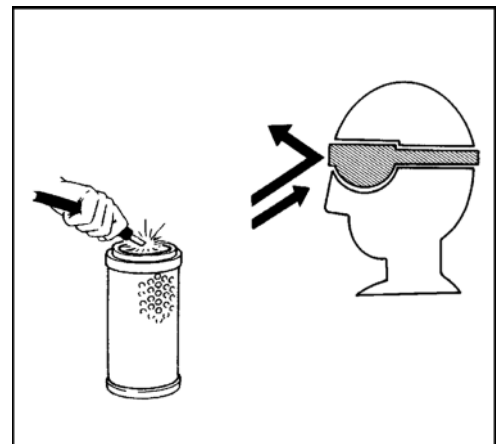

Replacing the fuel filter

- Open the engine compartment cover (page 106).
- Turn the cock (1) at the water separator to the OFF position.
- Remove the fuel filter (2).
- Wet the rubber seal of the new filter with fuel.
- Install a new filter and tighten it by hand.
- Set the cock to the ON position.
- Bleed the fuel system (page 103).
- Check the fuel filter for leaks.

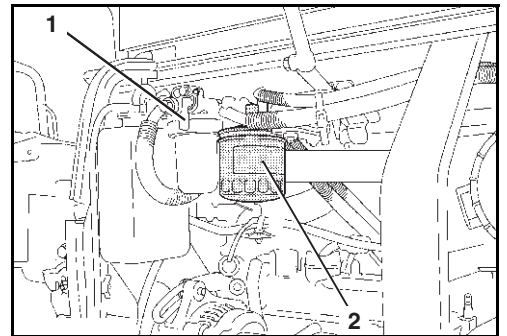

Dispose of cleaning cloths according to the applicable environmental protection regulations.

- Close the engine compartment cover.

Checking and cleaning the water separator



Water and impurities in the fuel settle in the water separator. A red plastic ring (4) in the water separator floats on the water. If such substances have deposited or the plastic ring has come up to the mark (5), the water separator must be emptied.

- Open the engine compartment cover (page 106).



Place a cleaning cloth under the water separator to prevent fuel from running onto the ground.

- Turn the cock (3) to the OFF position.
- Unscrew retainer (1) while holding on to the cup (2).
- Remove the cup.

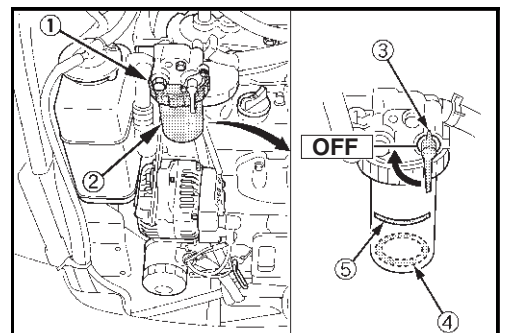

- Empty the cup (5) and clean with clean diesel fuel.
- Check filter (1) for excessive dirt; replace it if necessary.
- Replace the oil ring (4) and lubricate it with diesel fuel.
- Assemble the components 1 to 6 in this exact order.



Do not forget the red plastic ring (2) and the compression spring (3).

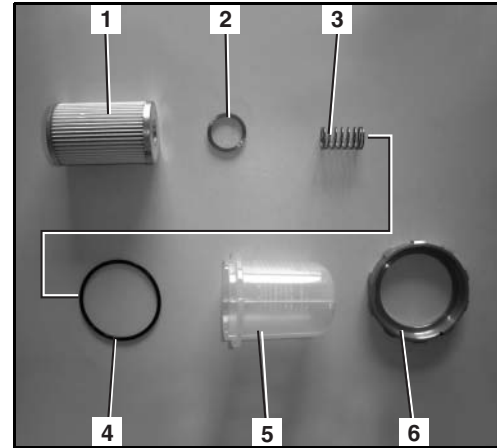

- Tighten retainer (6) manually, do not use tools.
- Set the cock to the ON position.
- Bleed the fuel system (page 103).
- Check the water separator for leaks.



Dispose of cleaning cloths according to the applicable environmental protection regulations.

- Close the engine compartment cover.

Draining the fuel tank

- Place a container with a minimum capacity of 12 litres under the fuel drain valve.
- Unscrew the drain plug (2).
- Open the drain valve (1) by turning to position (B) and drain the water.
- Close the drain valve by turning to position (A).
- Screw the drain plug back in.

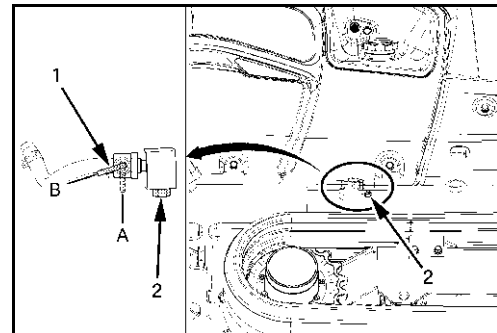

Dispose of fluid in the container according to the applicable environmental protection regulations.

Checking the fuel lines and the air intake hoses

- Open the engine compartment cover (page 106).
- Check all accessible fuel lines, air intake hoses and clamps to ensure that they are not damaged and are firmly seated.
- Repair or replace damaged parts.
- Close the engine compartment cover.

Maintenance

Replacing the return filter in the hydraulic oil tank



Pay attention to utmost cleanliness when servicing the hydraulic system.



This service may only be carried out after the hydraulic oil has cooled down.

- Take the bottom plate (1) out.
- Unscrew cap (1) with filter wrench.
- Dismantle the return flow filter (3) and replace with a new one.



Discard the return filter in accordance with the prevailing environmental protection regulations.

- Check state of the oil ring (2) of the cap, if necessary replace.
- Insert cap and mount.

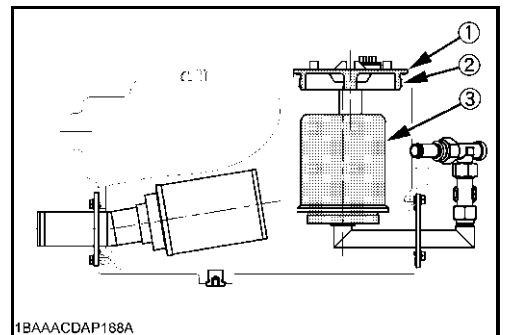
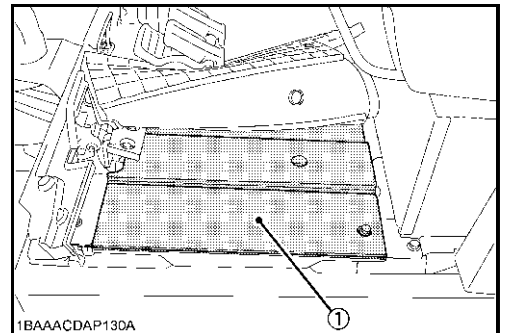

Replacing the suction filter in the hydraulic oil tank



Pay attention to utmost cleanliness when servicing the hydraulic system.



This service may only be carried out after the hydraulic oil has cooled down.



The suction filter must be replaced along with the hydraulic oil.

- Drain the hydraulic oil (page 133).
- Remove the return filter from the hydraulic oil tank (page 131).
- Remove the suction filter (1).
- If necessary, remove any residues with a clean, lint-free cloth.



Discard the suction filter and cleaning cloth in accordance with applicable environmental protection regulations.

- Install a new filter and tighten it by hand.
- Insert the return filter (page 131).
- Fill hydraulic oil (page 133).

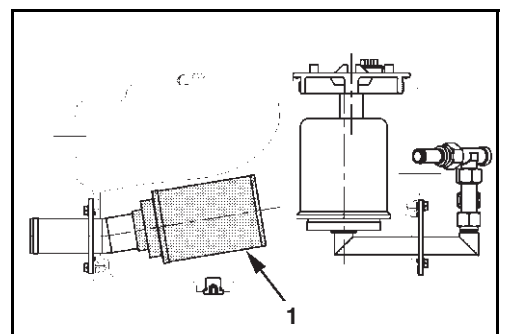

Topping up/changing the hydraulic oil



Pay attention to utmost cleanliness when servicing the hydraulic system.



This service may only be carried out after the hydraulic oil has cooled down.



The suction filter must be changed along with the hydraulic oil.

- Park excavator on level surface.
- Lower front attachments and dozer down to the bottom, as shown in the figure.
- Stop the engine.

- Open bottom plate (1).

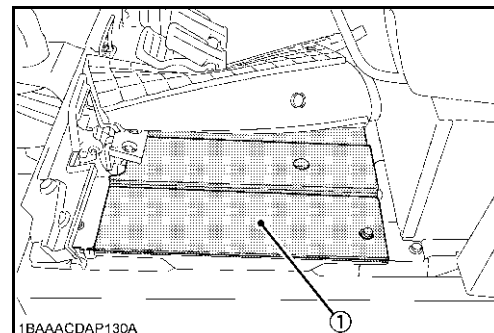
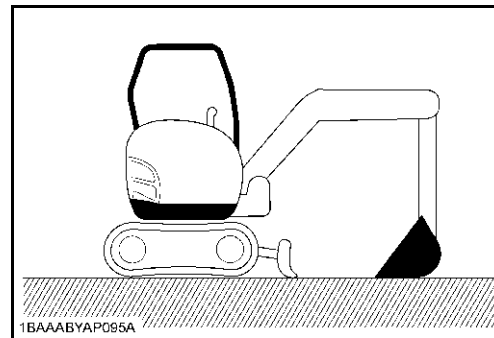

Maintenance

Draining the hydraulic oil

- Place a container with a minimum capacity of 70 litres under the hydraulic oil drain plug.
- Remove the drain plug (1) and drain the hydraulic oil.
- Install the drain plug with a new sealing ring.

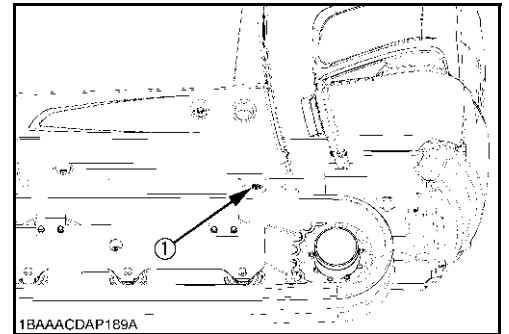

Filling the hydraulic oil

Filling quantity with oil change: approx. 14,2 L

Total hydraulic system capacity: 27 L

- Remove the filler plug (1) from the hydraulic oil tank.
- Insert a clean funnel with a strainer into the filler plug opening.

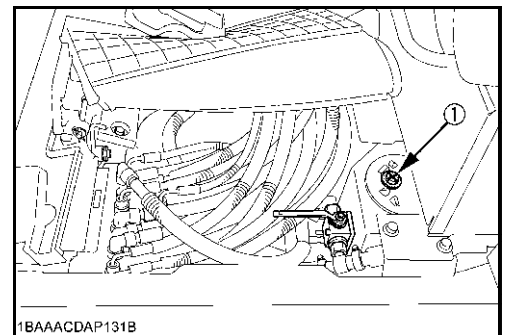

- Fill hydraulic oil to half way up the sight glass (1).
- Refit the plug of the hydraulic oil tank.
- Start the engine (page 67) and operate all control functions.
- Lower the front attachments and the dozer onto the ground (page 132).
- Stop the engine.
- Check the hydraulic oil level, add oil if necessary.
- Replace the bottom plate (1).

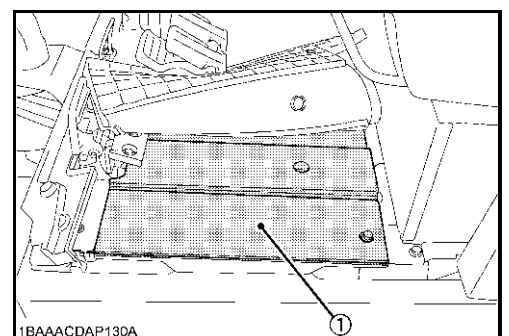
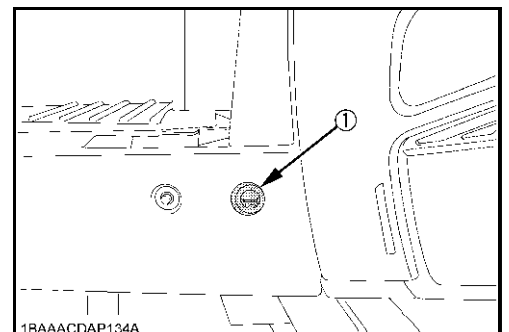

Battery service

Regular maintenance can extend the life cycle of the battery considerably.



When servicing a battery, always wear suitable protective gloves and eye protection.

Checking the battery

- Open the side cover (page 107).



Do not open maintenance-free batteries!

- Check battery (1) for tight fit, if necessary screw tight.



Be careful when cleaning the positive terminal - risk of short circuit! Do not use metal tools.

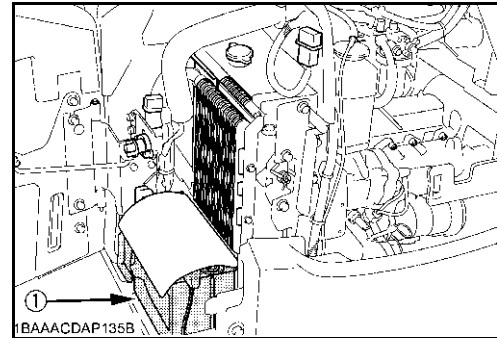

- Check battery poles for cleanness, if necessary clean and grease with petroleum jelly.
- Close the side cover.

Charging the battery



Battery acid is very caustic. Avoid contact with battery acid under all circumstances. If clothing, skin or eyes have come in contact with battery acid, rinse the affected parts immediately with water. If the eyes are affected, immediately seek medical attention! Neutralise spilled battery acid immediately.



When servicing a battery, always wear suitable protective gloves and eye protection.



Charge batteries only in sufficiently ventilated rooms. Smoking, uncovered lights or fire are not allowed in these rooms.



Explosive gas is created when charging batteries. Open flames can cause an explosion.



Remove the fill caps when charging batteries that are virtually empty. Leave the fill caps inside (not empty) batteries that are only charged for maintenance purposes, the fill caps can stay in the batteries.



The battery can only be charged if the starter switch is in the STOP position and the key removed.

- Make the battery accessible.

Maintenance

- Check the electrolyte level in the battery, adding distilled water if required.



When disconnecting and connecting the battery, always observe the specified order → risk of short circuit.

- Remove the negative terminal cover and take off the cable clamp. Put the clamp to the side so that contact with the negative terminal is excluded.
- Remove the positive terminal cover.
- Connect the battery charger to the battery according to the instructions of the charger manufacturer. Choose the normal (gentle) charging method.
- Clean the battery after charging and replenish the electrolyte, if necessary.
- Check the acid density with a hydrometer. The acid density should be between 1.24 and 1.28 kg/L. If the acid density differs considerably among the individual cells of a battery, the battery probably has a defect. Check the affected battery with a battery tester and contact trained personnel.

Installing/uninstalling and replacing the battery



When disconnecting and connecting the battery, always observe the specified order → risk of short circuit.

- Make the battery accessible.
- Remove the negative terminal cover and take off the cable clamp. Put the clamp to the side so that contact with the negative terminal is excluded.
- Remove the plus terminal cover and take off the cable clamp. Put the clamp to the side so that contact with the positive terminal is excluded.
- Remove the battery retainer and lift the battery out of the swivel frame.



When replacing the battery, always install a battery of the same type with the same power rating and the same dimensions.

- Before installation, cover the battery terminals and cable clamps with petroleum jelly.
- Install the battery in the swivel frame and fasten it with the battery retainer. Check the battery for tightness → do not operate the excavator with a loose battery.
- Connect the positive cable clamp to the positive terminal (+) of the battery, install the positive terminal cover.
- Connect the negative terminal (-) of the battery, install the negative terminal cover.

Lubrication

The following describes all lubricating tasks which should be performed with the superstructure.

Greasing the swivel gear

- Fill grease through the grease nipple (1) with a grease gun.



Grease at each 90° position of the swivel gear. Fill a total of approx. 50 g of grease (approx. 20 shots with the grease gun). Refer to the "Recommended lubricants" section (page 145).



When moving the swivel frame, make sure no person or material is in the swivel area. Turn the starter switch to the STOP position and remove the key before the next greasing procedure.

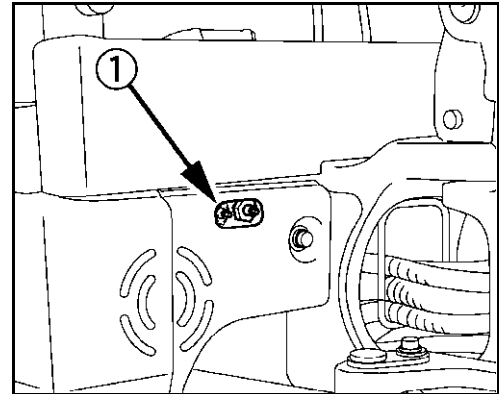

- Operate the excavator and swivel the swivel frame by 90° several times. After greasing, swivel the swivel frame 360° several times to distribute the grease evenly.

Greasing the pitch bearing

- Fill grease through the grease nipple (1) with a grease gun.



Grease at each 90° position of the pitch bearing. Using the grease gun, apply 5 shots at every position. Refer to the "Recommended lubricants" section (page 145).



When moving the swivel frame, make sure no person or material is in the swivel area. Turn the starter switch to the STOP position and remove the key before the next greasing procedure.

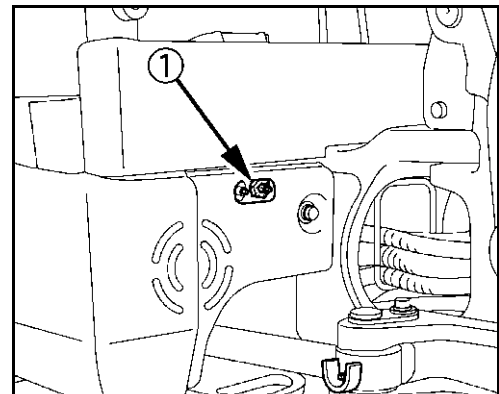

- Operate the excavator and swivel the swivel frame by 90° several times. After greasing, swivel the swivel frame 360° several times to distribute the grease evenly.

Greasing the swing bracket

- Lubricate both greasing points (see figure to the right) – see the "Recommended lubricants" section (page 145) – by injecting grease until fresh grease emerges.



Wipe emerged grease off immediately and store dirty cleaning cloths in the containers provided for disposal.

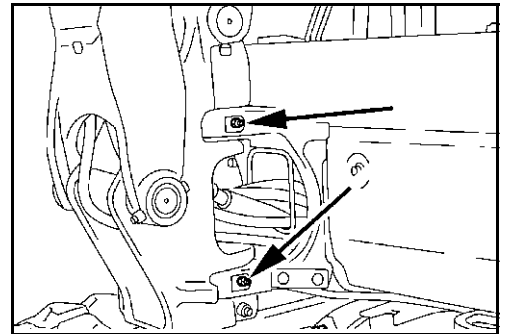

Other greasing points

- Start the engine (page 67).
- Position the boom, arm, and dozer as shown in the figure. Stop the engine, remove the key. Refer to the "Operating the controls during excavation work" section) (page 77).

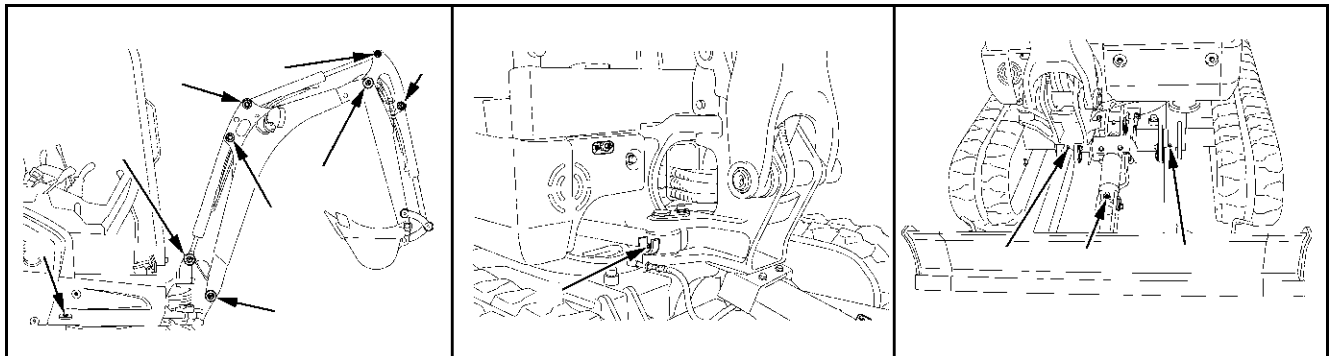

- Lubricate all greasing points with grease – see the "Recommended lubricants" section (page 145) – until fresh grease emerges.



Wipe emerged grease off immediately and store dirty cleaning cloths in the containers provided for disposal.

Checking and tensioning the crawler tension



If the crawlers are too tight, wear is increased.



If the crawlers are too loose, wear is increased and the crawlers may come off.

When parking an excavator with rubber crawlers, ensure that the seam (∞) is on top half way between the two sliders (see figure/1, "Checking the crawler tension", page 138).

- Clean all parts of the running gear, paying particular attention to stones between the crawler and sprocket or idler. Clean the area of the crawler tensioning cylinder.
- Swivel the swivel frame 90° to the direction of travel as shown in the figure.
- Lower the front attachments on the ground and raise the excavator about 200 mm off the ground on one side.

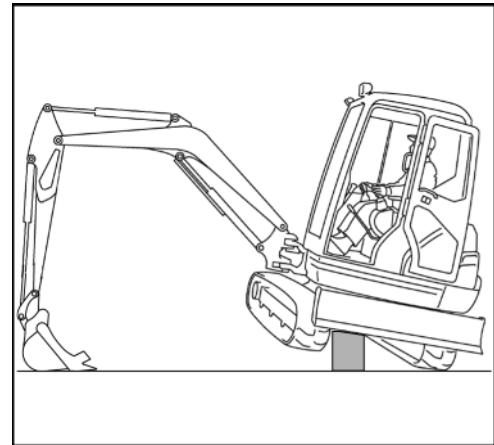

Have a guide supervise the procedure.



Support the excavator with appropriate backing material, observing the vehicle weight.

Checking the crawler tension

- The crawler seam (1) is half way between the idler and sprocket.
- Check the crawler sag as shown in the figure.

Crawler sag "A" 10-15 mm

- If the crawler sag is more than 25 mm, adjust the crawler.
- If necessary, tighten or loosen the crawler.
- Start the engine and rotate the lifted crawler briefly.

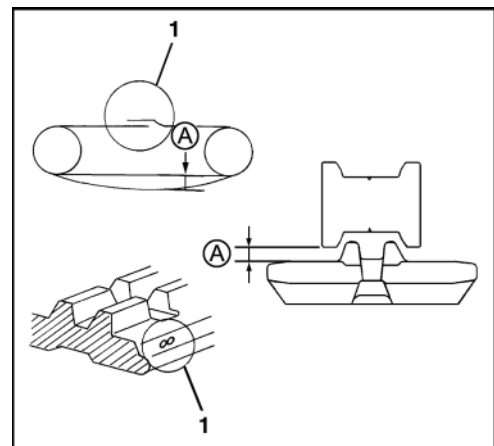

Caution: The area around the rotating crawler must be free of persons. Turn the starter switch to the STOP position after turning and remove the key.

- Recheck the crawler tension, readjusting it if necessary.
- Perform the procedures on the second crawler.

Adjusting the crawler tension

Tightening the crawlers

- Position the grease gun (2) on the grease nipple (1).
- Pump the grease gun until the specified crawler tension is obtained.

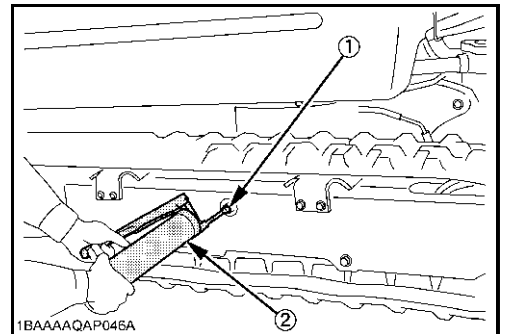

Loosening the crawlers

- Cautiously unscrew the pressure valve and loosen the crawler.



Grease could squirt out from the cylinder opening.

- Screw in the pressure valve and torque to 100-110 Nm.
- Tighten the crawler.

Replace the drive unit oil



Only change the oil when the drive unit is warm to the hand; if not, drive the excavator warm.

- Park the excavator on level ground so that the drain plug (figure below, position 2) is positioned at the bottom.
- Place a catch tray with a minimum capacity of 2 L under the drain plug.
- Remove the drain plug and let the oil drain completely. Install the drain plug with a new sealing ring on it.
- Unscrew the filler plug (1).
- Fill oil as specified in the "Recommended lubricants" section (page 145). The oil level is the lower edge of the thread.

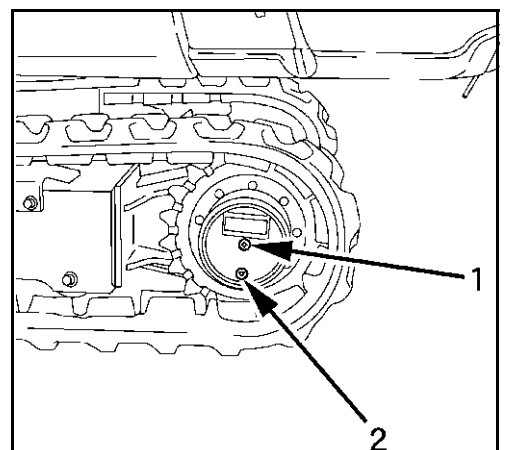

Capacities: 0.33 L

- Provide filler plug with new oil ring and screw in.
- Perform the same service on the second drive unit.

Check, clean and replace the fresh air filter



If the excavator is used in especially dusty surroundings, the fresh air filters must be checked more often.

- Open the side cover (page 107).
- Pull safety pin (1) at the cover plate (2).
- Pull assembly pin (3) out of the cover plate.
- Slide up cover plate with the assembly pin and take from cladding together with the fresh air filter.

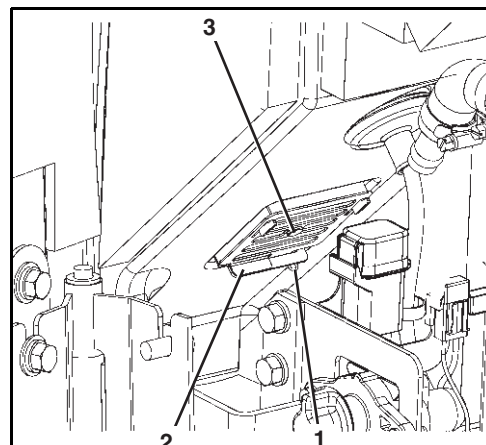

Checking

- Check fresh air filter for soiling and damage. If there is too much soiling or damage, the fresh air filter must be replaced.

Cleaning



Clean only with filtered air at max. 2 bar pressure.



Always wear eye protection when working with compressed air.

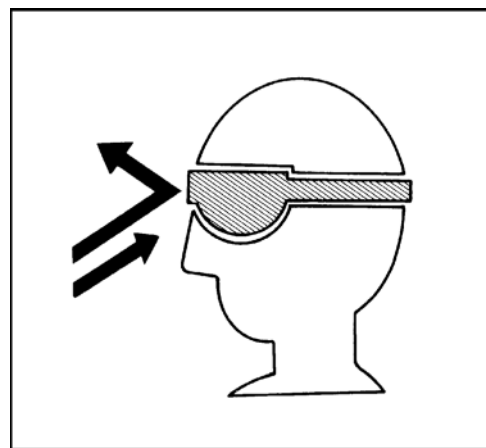

- Clean the filter (1) with compressed air in direction "A", opposite the normal direction of flow.



Take care not to damage the filter when installing it. When using a damaged filter, dirt will get into the heater assembly and lead to considerable damage there.

- Insert fresh air filter.
- Insert safety pin.
- Close the side cover (page 107).

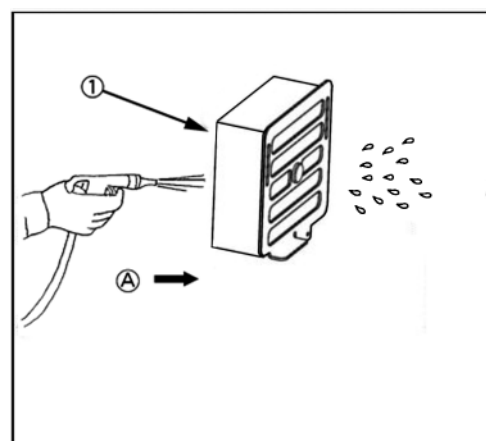

Checking the pipes and hoses of the heating system



Carry out the inspection while the engine is cold.

- Open the engine compartment cover (page 106).
- Open the side cover (page 107).
- All conduits and hose lines of the heater must be checked for state (cracks, bulging, hardening) and tight fit. If there are any defects found, consult your KUBOTA dealer. Only trained staff may work on the heater.
- Close the engine compartment and side cover.

Changing the Line Filter



The replacement procedures are explained with the LH control lever as an example; the RH control lever filter replacement should be performed in the same manner.

- Release the pilot circuit pressure.
- Raise the LH control console (1).
- Remove the lower trim panels.
- Remove the hydraulic line (white).
- Unscrew the line filter (2).
- Screw in a new filter.
- Reconnect the hydraulic line.
- Reinstall the trim panels.
- Change the RH control lever line filter.

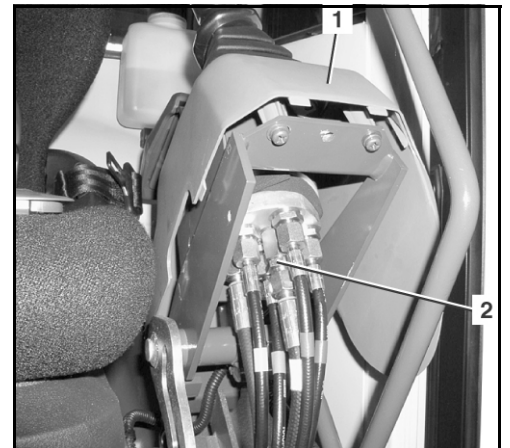

Changing the auxiliary valve filter

- Release the pilot circuit pressure.
- Remove the floor mat.
- Remove the right hand bottom plate (1).
- Remove the hydraulic line (2).
- Unscrew the line filter (3).
- Screw in a new filter.
- Reinstall the hydraulic line.
- Replace the right hand bottom plate.
- Replace the floor mat.

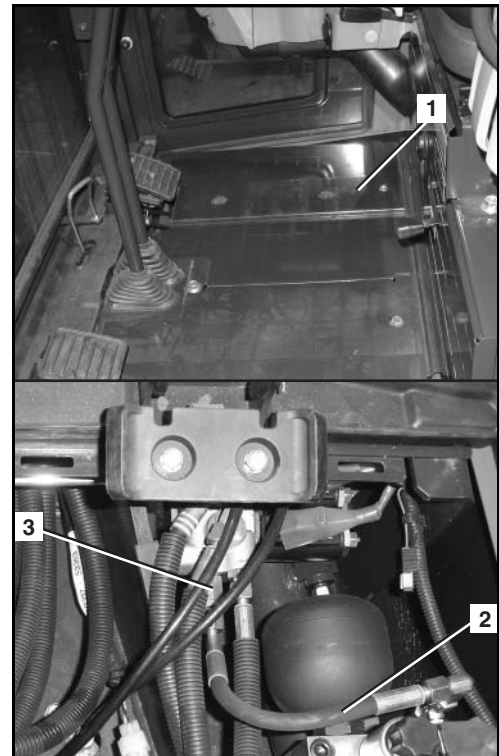

Checking the bolted joints

The table below contains the torques for nuts and bolts. These may only be tightened with a torque wrench. Missing torques can be requested from KUBOTA.

Tightening torque for screws

Nm (kgf•m)

	4 T (4.6)	7 T (8.8)	9 T (9.8-10.9)
M 6	7.8~9.3 (0.8~0.95)	9.8~11.3 (1.0~1.15)	12.3~14.2 (1.25~1.45)
M 8	17.7~20.6 (1.8~2.1)	23.5~27.5 (2.4~2.8)	29.4~34.3 (3.0~3.5)
M 10	39.2~45.1 (4.0~4.6)	48.1~55.9 (4.9~5.7)	60.8~70.6 (6.2~7.2)
M 12	62.8~72.6 (6.4~7.4)	77.5~90.2 (7.9~9.2)	103.0~117.7 (10.5~12.0)
M 14	107.9~125.5 (11.0~12.8)	123.6~147.1 (12.6~15.0)	166.7~196.1 (17.0~20.0)
M 16	166.7~191.2 (17.0~19.5)	196.1~225.6 (20.0~23.0)	259.9~304.0 (26.5~31.0)
M 20	333.4~392.3 (34.0~40.0)	367.7~431.5 (37.5~44.0)	519.8~568.8 (53.0~58.0)

Note: Use screws 9 T for canopy assembly, but tighten with torque indicated for screws 7 T.



The maximum torque of the plastic trim bolted connections between the operator's place and the engine compartment may not exceed 21 Nm. When tightening the screws with a torque higher than 21 Nm, the plastic trim helicoil inserts will be loosened or destroyed.

Tightening torque for hose clamps

Size	Code #	Hydraulic oil	Water	Air
10-16	69741-7287-0	5.4 Nm	3.0 Nm	2.0 Nm
13-20	69481-1116-0	5.4 Nm	3.0 Nm	2.0 Nm
16-25	69741-7281-0	5.4 Nm	3.0 Nm	2.0 Nm
22-32	69741-7284-0	5.4 Nm	3.0 Nm	2.0 Nm
25-40	69741-7282-0	5.4 Nm	3.0 Nm	2.0 Nm
40-60	69481-1518-0	5.4 Nm	3.0 Nm	2.0 Nm
32-50	69741-7283-0	5.4 Nm	3.0 Nm	2.0 Nm
50-70	69741-7285-0	5.4 Nm	3.0 Nm	2.0 Nm

Tightening torque for hydraulic hoses

Wrench size	Torque in Nm	Hose size	Thread
14	15-20	DN 4-1/8"	M12x1.5
17	15-20	DN 6-1/4"	M14x1.5
19	30-35	DN 8-5/16"	M16x1.5
22	40-45	DN 10-3/8"	M18x1.5
27	50-55	DN 13-1/2"	M22x1.5

Are also valid for adaptor with premounted nut.

Tightening torque for hydraulic pipes

Wrench size	Torque in Nm	Pipe size	Thread
17	30-35	6x1	M12x1.5
17	30-35	8x1	M14x1.5
19	40-45	10x1.5	M16x1.5
22	60-65	12x1.5	M18x1.5
27	75-80	15x1.5	M22x1.5
30	90-100	16x2	M24x1.5
32	110-120	18x2	M26x1.5
36	130-140	22x2	M30x2
41	140-160	25x2.5	M36x2
27	60-65	15x1.5	M22x1.5 for ED-2 only

Tightening torque for hydraulic adapters

Thread	Wrench size	Torque in Nm	Pipe size	Thread
1/8"	14	15-20	4x1	M10x1.0
1/8"	17	25-35	6x1	M12x1.5
1/4"	19	34-45	8x1	M14x1.5
1/4"	19-22	40-55	10x1.5	M16x1.5
3/8"	22-24	45-65	12x1.5	M18x1.5
1/2"	27	70-80	15x1.5	M22x1.5
1/2"	27	80-90	16x2	M24x1.5
3/4"	32	100-120	18x2	M26x1.5
1"	36	120-140	22x2	M30x2

Recommended lubricants



- The excavator is shipped with Shell Tellus S2M46 hydraulic oil!
- If bio oil is used, please contact your KUBOTA dealer.
- Use only API CF or API CI-4 grade engine oil. Do not use different grades, such as CF-4, CG-4 or CH-4.
- For the drive units use gear oil SAE 90 (API, CLA/GL5) in all seasons.
- The use of diesel fuel with a sulphur content of less than 0.10 % (1000 ppm) is strongly recommended.
- When diesel fuel with a high sulphur content [between 0.50 % (5000 ppm) and 1.0 % (10000 ppm)] is used, the engine oil and engine oil filter must be replaced at shorter intervals (roughly half as long).
- Never use diesel fuel with a sulphur content exceeding 1.0 % (10000 ppm).
- Diesel fuels complying with the current EN 590 or ASTM D975 are recommended.
EN: European standard
ASTM: American Society for Testing and Materials

	Range of use	Viscosity	Shell	Mobil	Exxon	MIL-Standard
1*	In winter or at low temperatures	SAE 10W	Shell Rotella T10W	Mobil Delvac 1310	XD-3 10W	MIL-L-2104C MIL-L-2104D
			Shell Rimula 10W		XD-3 Extra 10W	
		SAE 20W	Shell Rotella T20W-2	Mobil Delvac 1320	XD-3 20W-20	
			Shell Rimula 20W-2		XD-3 Extra 20W-20	
	In summer or at high ambient temperatures	SAE 30	Shell Rotella T30	Mobil Delvac 1330	XD-3 30	
			Shell Rimula 30		XD-3 Extra 30	
	SAE 40	Shell Rotella T40	Mobil Delvac 1340	XD-3 40		
		Shell Rimula 40		XD-3 Extra 40		
All-weather engine oil	Multi-grade oil	Shell Rotella T15W		XD-3 15W-40 XD-3 Extra 15W-40		
2*	In winter or at low temperatures	SAE 75	Shell Oil S 8643	Mobilube HD80W-90		MIL-L-2105C
			Shell Spirax HD80W		Mobilube HD80W-90	
	In summer or at high ambient temperatures	SAE 90	Shell Spirax HD90	Mobilube 46		MIL-L-2105
				Mobilube HD80W-90		MIL-L-2105C
		SAE 140	Shell Spirax HD140	Mobilube HD85W-140 Mobilube HD80W-140		MIL-L-2105C
All-weather gear oil	Multi-grade oil	Shell Spirax HD80W Shell Spirax HD85W	Mobilube HD80W-90	GX80W-90	MIL-L-2105C	
3*	In winter or at low temperatures	ISO 32	Shell Tellus S2M32	Mobil DTE-Oil 13	NUTO H32	
		ISO 46	Shell Tellus S2M46	Mobil DTE-Oil 15	NUTO H46	
	In summer or at high ambient temperatures	ISO 68	Shell Tellus S2M68	Mobil DTE-Oil 16	NUTO H68	
Grease		Shell Alvania EP2	Mobilux EP2	BEACON Q2		
Fuel	Summer diesel (ASTM D975/EN 590)					
Fuel below -5 °C	Diesel fuel for cold weather operation					
Antifreeze for the cooling system	G048	Antifreeze, free from nitrate, phosphate and amine according to the MB specification 325.0				
Special grease for use during the first 50 hours of operation	NLGI-1	WEICON ANTI-SEIZE				

- 1* Engine oil
- 2* Gear oil
- 3* Hydraulic oil

Excavator repairs

Repairs on the excavator may only be carried out by trained personnel.

If repairs are carried out on supporting parts, for example welding on frame parts, the work must be checked by an expert.

After repairs the excavator may only be taken into operation if its proper operation has been determined. For this check particular attention must be paid to the repaired parts and the safety devices.

Safety inspection

All safety inspections are based on the national worker's protection regulations, safety regulations and technical specifications applicable to the country where the machine is deployed.

The owner (operator) (page 13) should arrange for the safety inspections to be performed at specified intervals according to national rules and regulations.

Due to his training and experience, the skilled person must have sufficient knowledge of excavators and be familiar with the applicable national worker's protection regulations, safety regulations and the generally accepted technical rules so that they can assess the safe condition of the excavator.

The expert must keep his appraisal and evaluation neutral and must not be influenced by personal, economic or company interests. The inspection is a visual and functional check of all components for condition and completeness and of the effectiveness of the safety devices.

The performance of the inspection must be documented as an inspection report containing at least the following information:

- Date and scope of the inspection indicating all pending checks,
- Result of the inspection with a report of the determined faults,
- Assessment in respect to starting or continuing operation,
- Information on necessary follow-up inspections and
- Name, address and signature of the inspector.

The owner/employer (company) is responsible for the observance of the inspection intervals. The acknowledgement and the elimination of the determined faults must be confirmed by the owner/employer in writing, along with the date, in the inspection report.

The inspection report must be kept on file at least until the next inspection.

Taking out of service and storage

If the excavator is taken out of service for up to six months, the measures before, during and after taking out of service must be carried out as described below. If the vehicle is to be taken out of service for a period of over six months, contact the manufacturer for additional measures.

Safety rules for taking out of service and storage

The general safety rules (page 13), the safety rules for operation (page 57) and the safety rules for maintenance (page 117) apply.

When taking the excavator out of service, secure it against unauthorised use.

Storage conditions

The storage place must have a sufficient bearing capacity for the weight of the excavator.

The storage place must be frost-free, dry and well ventilated.

Measures before taking out of service

- Clean and dry the excavator thoroughly (page 123).
- Check the hydraulic oil level, add hydraulic oil if necessary (page 132).
- Change the engine oil and oil filter (page 126).
- Drive the excavator to the storage place.
- Remove the battery (page 135) and store it in a dry and frost-free room. If necessary, connect it to a trickle charger.
- Grease the swivel gear (page 136).
- Grease the pitch bearing (page 136).
- Grease all other greasing points (page 137).
- Grease the swing bracket (page 137).
- Grease the bucket bolt and bucket linkage bolt (page 62).
- Check the antifreeze content of the coolant, add coolant if necessary (page 123).
- Grease the hydraulic cylinder piston rods.

Measures during taking out of service

- Charge the battery regularly (page 134).

Start-up after taking out of service

- If necessary, clean the excavator thoroughly (page 123).
- Check the hydraulic oil for condensate water. Replace the oil if necessary (page 132).
- Remove the grease from the piston rods of the hydraulic cylinders.
- Install the battery (page 135).
- Check the safety devices for proper operation.
- Carry out the pre-operational services (page 60). If defects are detected during start-up, repair the defects before proceeding.
- If the safety inspection is due while the vehicle has been taken out of service, the inspection must be performed before start-up.
- Start the engine (page 67). Run the excavator at idle and check all functions.

Lifting capacity of the excavator

Constructive calculation of lifting capacity

- The lifting capacity of the excavator is based on ISO 10567 and does not exceed 75 % of the static tipping load or 87 % of the hydraulic lifting capacity of the machine.
- The lifting capacity is measured at the front pin part of the arm with the arm fully extended. The arm is fully in the dump position. The boom cylinder is the operating cylinder.

- The lifting conditions are:

1. Swivel up to 360°

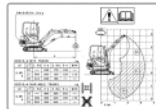

2. Over front end, dozer down



- As well as the lifting conditions, the length of the arm also affects the permitted lifting capacities and the stability of the machine. Compare the dimensions of the machine arm with the details given in the lifting capacity tables, in order to use the correct lifting capacity table for your machine.



Dimensions for the arm, see table "Design of arm" in the section "Dimensions" (page 36).

Lifting attachment

- The machine may not be deployed for lifting operation unless there is a pipe safety valve installed on the boom cylinder and on the arm cylinder according to EN 474-5. An additional pipe safety valve in accordance with EN 474-1 must be installed before using the dozer for lifting operation support.
- When the overload warning function is enabled, the machine may be used for lifting operation only. For more information, see chapter Accessories, section KUBOTA Pipe safety valve (page 160).
- The lifting attachment is to be attached to the implement or to other parts of the excavator in such a manner as to exclude the possibility of the lifting rope accidentally unhooking.
- Attachment to the implement or the equipment must be such as to guarantee the optimum field of vision between the operator and the guide [the person who fastens the lifting rope to the lifting attachment].
- The lifting attachment is to be positioned so that the lifting rope is not deflected from its vertical direction of tension by other parts of the machine.
- The lifting attachment must be formed and positioned in such a manner as to exclude the possibility of the lifting rope accidentally slipping.
- Care must be taken when positioning the lifting attachment that there is no risk of restriction (e.g. becoming caught on something) during normal operation of the excavator or when working on any particular object.
- Load suspensions (e.g. hooks) may only be welded on by suitably qualified personnel. For this type of work, please contact your KUBOTA dealer.
- At every point of the implement or the boom, the lifting attachment must withstand a load of two-and-a-half-times its rated lifting load.

Lifting capacity of the excavator

Load suspension device

Assumed is a load suspension device with all the characteristics listed below.

- The system must withstand a load two-and-a-half-times its rated lifting load, irrespective of the point at which that load is applied.
- The system must be designed in such a way as to practically exclude any objects which have been lifted falling from the lifting attachment, for example by means of a protective attachment designed for this purpose.
- The system must not allow the lifting attachment to slip from the implement to be lifted.



Do not lift loads which exceed the values indicated in the lifting capacity tables.



Always observe the maximum permissible lifting capacity of the hoisting gear (e.g. load hooks). The lifting of loads over the maximum permissible lifting capacity is not allowed.



The values given in the tables apply only to level and hard grounds. When working on soft ground, the machine can tip over easily, as the load is concentrated on one side only and the track or the dozer can dig into the ground.



The values given in the tables apply only for loads without bucket. If a bucket is used, the weight of the bucket must be subtracted from the values in the tables. The weight of mounted accessories (e.g. clamp kit, quick release coupling, etc.) must be subtracted from the lifting capacity.



It is not allowed to swing the boom during lifting operation. The whole machine could tilt!

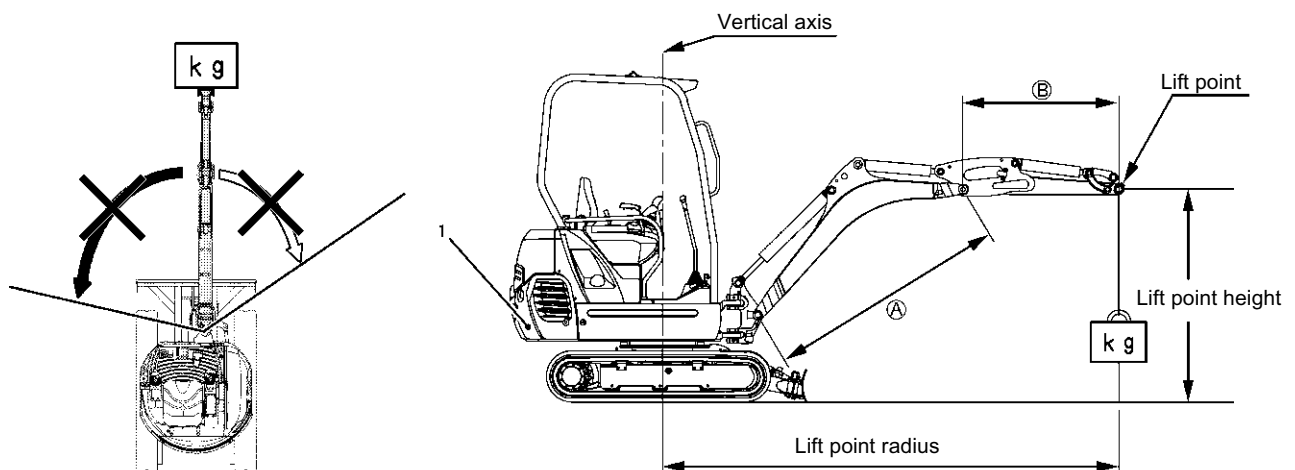

		Counterweight (1)	(A)	(B)
KX015-4	Canopy	60 kg	1.69 m	0.95 m
	Cab	10 kg		
KX016-4	Canopy	60 kg	1.69 m	0.95 m
	Cab	10 kg		
KX018-4	Canopy/Cab	60 kg	1.69 m	1.09 m
KX019-4 SF	Canopy/Cab	90 kg	1.69 m	1.09 m
KX019-4	Canopy/Cab	90 kg	1.81 m	1.19 m

Max. lifting load during swivel operation is 360°

KX015-4, KX016-4 (cab) / arm 950 mm

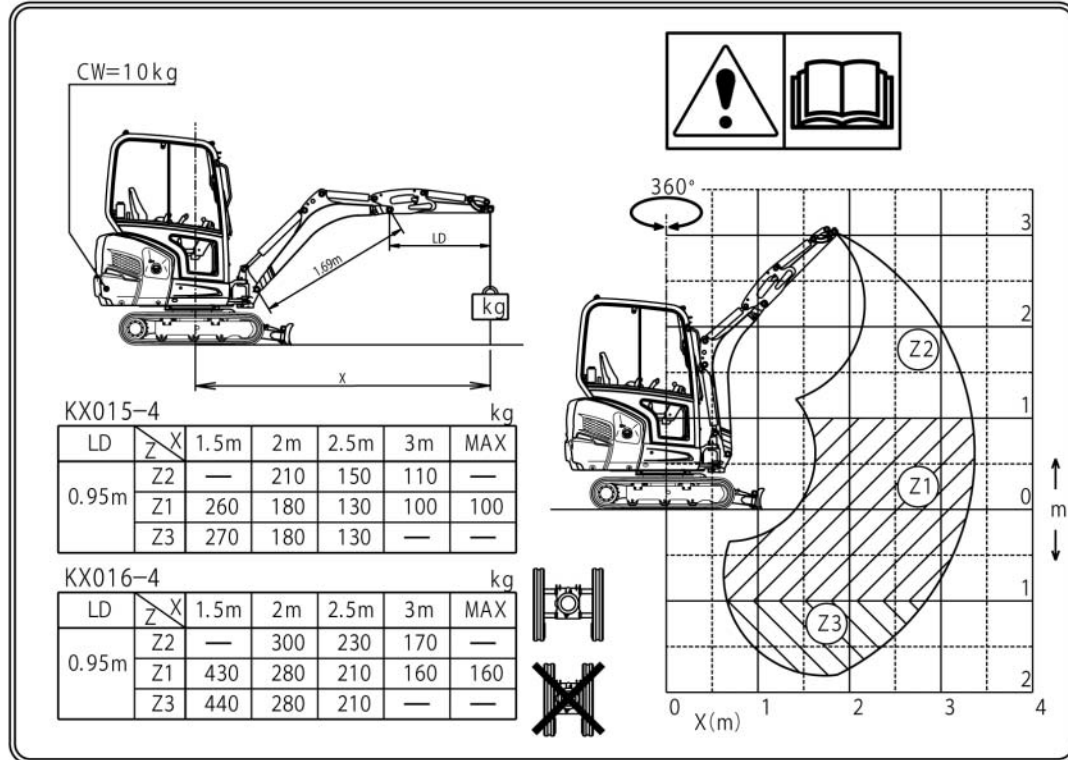

KX018-4, KX019-4 (cab) / arm 1090 mm and arm 1190 mm

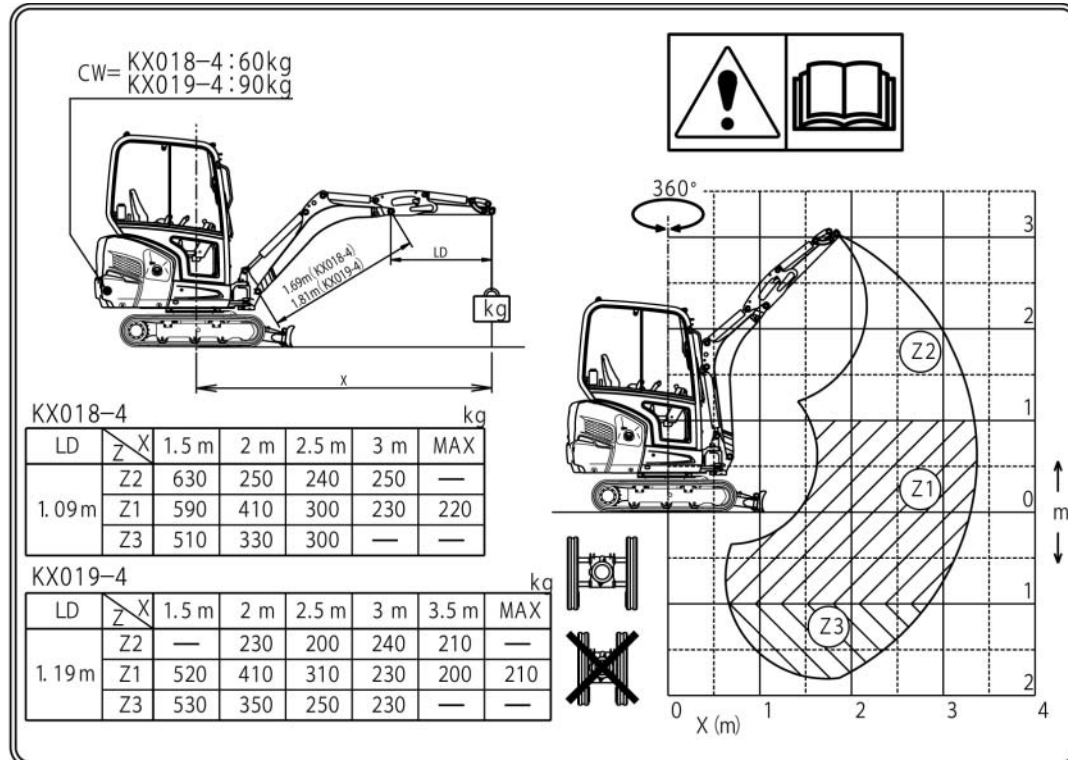

Lifting capacity of the excavator

KX019-4 SF (cab) / arm 1090 mm

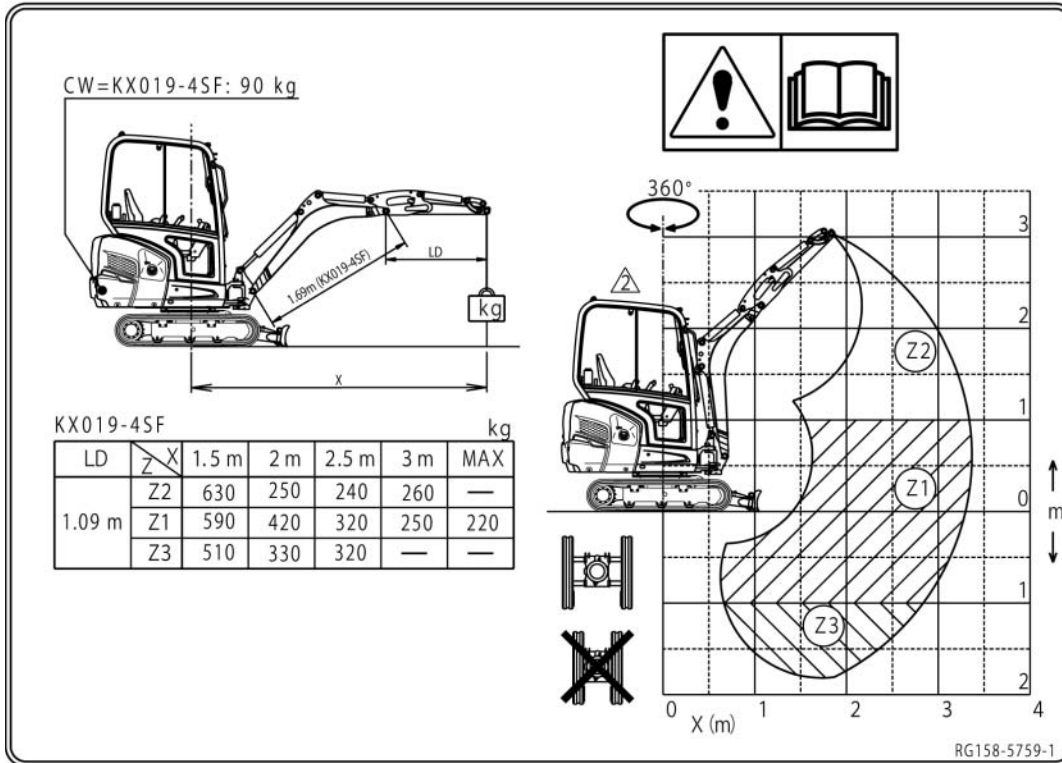

KX015-4, KX016-4 (canopy) / arm 950 mm

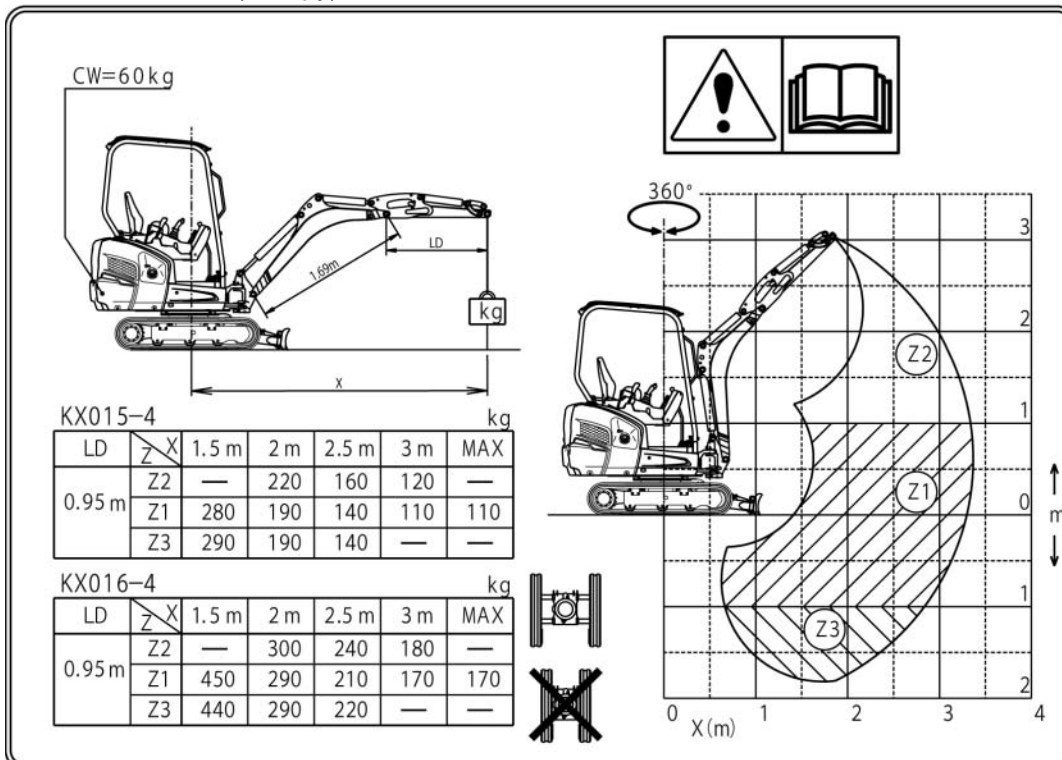

KX018-4, KX019-4 (canopy) / arm 1090 mm and arm 1190 mm

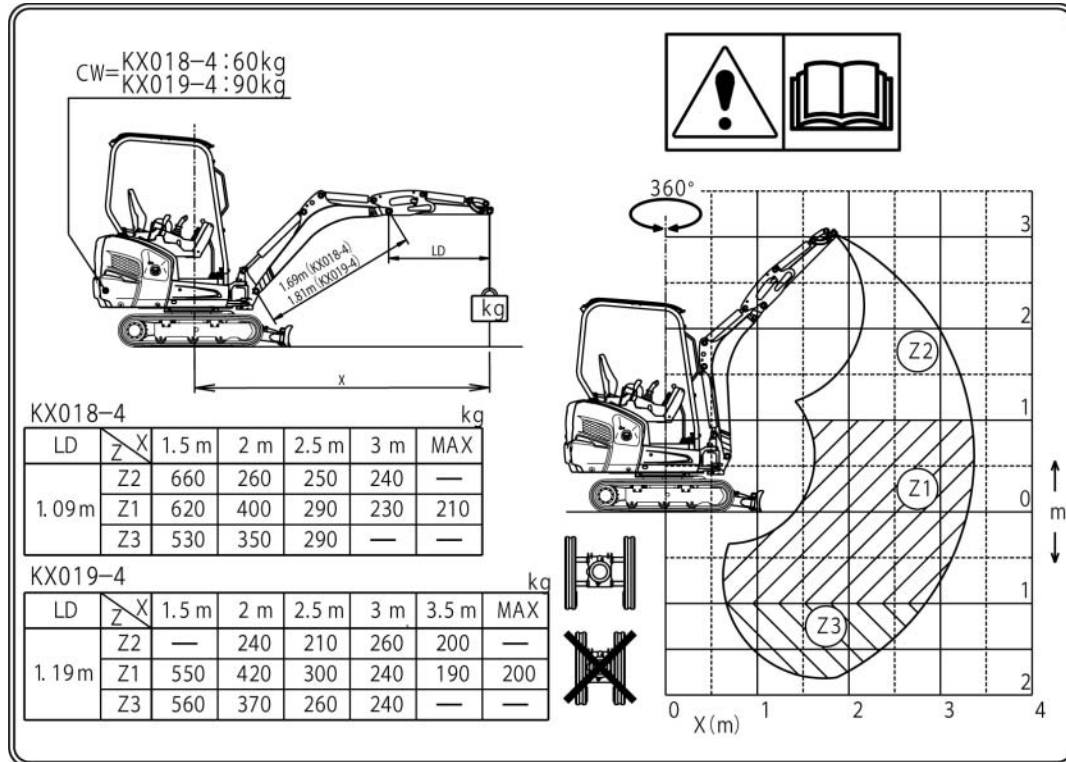

KX019-4 SF (canopy) / arm 1090 mm

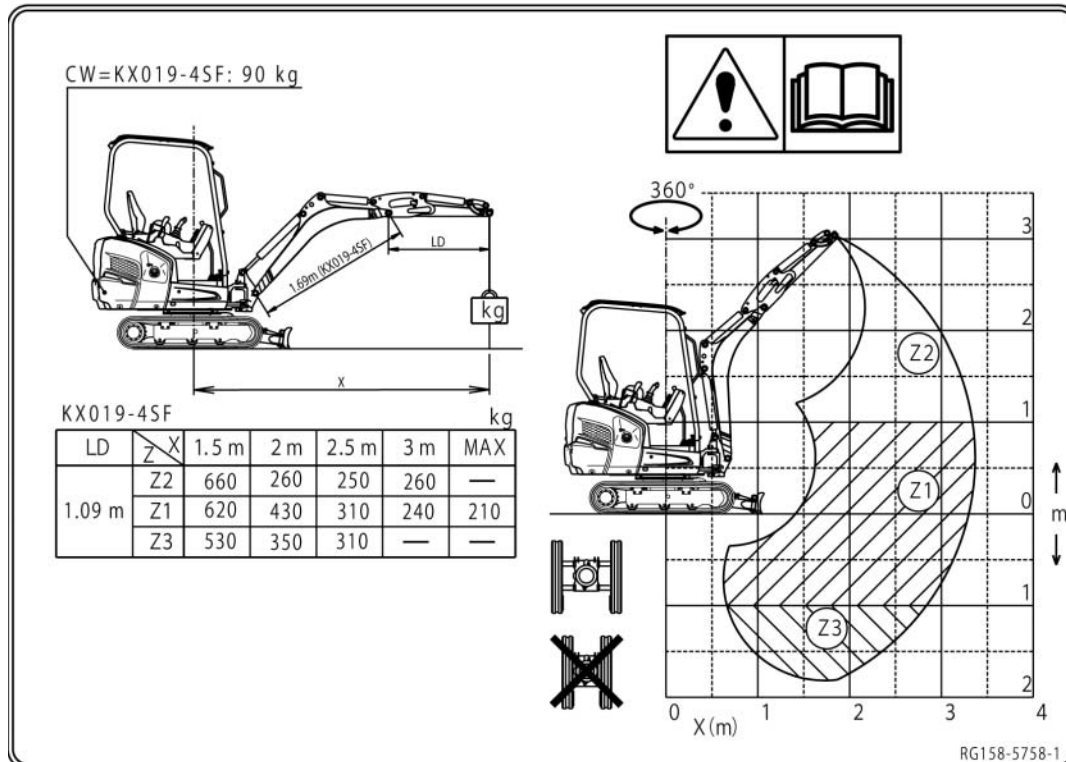

RG158-5758-1

Lifting capacity of the excavator

Lifting capacity over front end, dozer down

MODEL	KX015-4	SPECIFICATION	CANOPY VERSION
	KBM		ARM 950 mm

LIFT POINT HEIGHT [mm]	Lift point radius (mm)										kN (t)	
			Mini-mum	1500	2000	2500	3000	Maxi-mum				
GL	4000											
	3500											
	3000											
	2500											
	2000							2.6 (0.27)				
	1500						2.9 (0.30)	3.0 (0.31)	2.8 (0.29)			
	1000						4.5 (0.46)	3.5 (0.36)	2.9 (0.30)	2.7 (0.28)		
	500						5.4 (0.55)	3.8 (0.39)	2.9 (0.30)			
	0					4.7 (0.48)	5.3 (0.54)	3.8 (0.39)	2.8 (0.29)			
	-500				5.3 (0.54)	7.0 (0.71)	4.8 (0.49)	3.4 (0.35)				
	-1000				8.5 (0.87)	5.9 (0.60)	4.0 (0.41)	2.8 (0.29)				
	-1500					4.3 (0.44)	2.8 (0.29)					
	-2000											
-2500												

Lifting capacity over front end, dozer down

MODEL	KX015-4	SPECIFICATION	CAB VERSION
	KBM		ARM 950 mm

LIFT POINT HEIGHT [mm]	Lift point radius (mm)										kN (t)	
			Mini-mum	1500	2000	2500	3000	Maxi-mum				
GL	4000											
	3500											
	3000											
	2500											
	2000							2.6 (0.27)				
	1500						2.9 (0.30)	3.0 (0.31)	2.8 (0.29)			
	1000						4.5 (0.46)	3.5 (0.36)	2.9 (0.30)	2.7 (0.28)		
	500						5.4 (0.55)	3.8 (0.39)	2.9 (0.30)			
	0					4.7 (0.48)	5.3 (0.54)	3.8 (0.39)	2.8 (0.29)			
	-500				5.3 (0.54)	7.0 (0.71)	4.8 (0.49)	3.4 (0.35)				
	-1000				8.5 (0.87)	5.9 (0.60)	4.0 (0.41)	2.8 (0.29)				
	-1500					4.3 (0.44)	2.8 (0.29)					
	-2000											
-2500												

Please observe the model name on the type plate (page 41).

Lifting capacity over front end, dozer down

MODEL	KX016-4	SPECIFICATION	CANOPY VERSION
	KBM	STANDARD TRACK WIDTH	ARM 950 mm

kN (t)

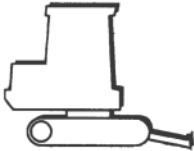
LIFT POINT HEIGHT [mm]	Lift point radius (mm)								Maximum							
	Minimum	1500	2000	2500	3000											
4000																
3500																
3000																
2500																
2000						2.6 (0.27)										
1500						2.9 (0.30)	3.0 (0.31)	2.8 (0.29)								
1000					4.5 (0.46)	3.5 (0.36)	2.9 (0.30)	2.7 (0.28)								
500					5.4 (0.55)	3.8 (0.39)	2.9 (0.30)									
GL 0					4.7 (0.48)	5.3 (0.54)	3.8 (0.39)	2.8 (0.29)								
-500			5.3 (0.54)	7.0 (0.71)	4.8 (0.49)	3.4 (0.35)										
-1000			8.5 (0.87)	5.9 (0.60)	4.0 (0.41)	2.8 (0.29)										
-1500				4.3 (0.44)	2.8 (0.29)											
-2000																
-2500																

Lifting capacity over front end, dozer down

MODEL	KX016-4	SPECIFICATION	CAB VERSION
	KBM	STANDARD TRACK WIDTH	ARM 950 mm

kN (t)

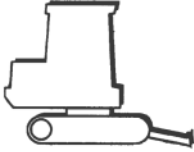
LIFT POINT HEIGHT [mm]	Lift point radius (mm)								Maximum							
	Minimum	1500	2000	2500	3000											
4000																
3500																
3000																
2500																
2000						2.6 (0.27)										
1500						2.9 (0.30)	3.0 (0.31)	2.8 (0.29)								
1000					4.5 (0.46)	3.5 (0.36)	2.9 (0.30)	2.7 (0.28)								
500					5.4 (0.55)	3.8 (0.39)	2.9 (0.30)									
GL 0					4.7 (0.48)	5.3 (0.54)	3.8 (0.39)	2.8 (0.29)								
-500			5.3 (0.54)	7.0 (0.71)	4.8 (0.49)	3.4 (0.35)										
-1000			8.5 (0.87)	5.9 (0.60)	4.0 (0.41)	2.8 (0.29)										
-1500				4.3 (0.44)	2.8 (0.29)											
-2000																
-2500																

Please observe the model name on the type plate (page 41).

Lifting capacity of the excavator

Lifting capacity over front end, dozer down

MODEL	KX018-4	SPECIFICATION	CANOPY VERSION
	KBM	STANDARD TRACK WIDTH	ARM 1090 mm

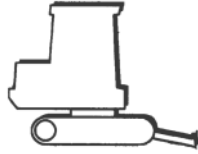
LIFT POINT HEIGHT [mm]	Lift point radius (mm)								kN (t)		
	Minimum	1500	2000	2500	3000	Maximum					
4000											
3500											
3000											
2500					2.6 (0.27)						
2000					2.5 (0.25)						
1500				2.5 (0.26)	2.8 (0.29)	2.8 (0.29)					
1000			6.5 (0.66)	4.3 (0.44)	3.5 (0.36)	3.0 (0.31)	2.7 (0.28)				
500					5.6 (0.57)	4.0 (0.41)	3.1 (0.32)				
0				6.1 (0.62)	5.8 (0.59)	4.1 (0.42)	3.1 (0.32)				
-500			5.9 (0.60)	7.9 (0.81)	5.3 (0.54)	3.8 (0.39)	2.8 (0.29)				
-1000			9.1 (0.93)	6.8 (0.69)	4.5 (0.46)	3.2 (0.33)					
-1500		11.4 (1.16)	5.2 (0.53)	3.4 (0.35)							
-2000											
-2500											

Lifting capacity over front end, dozer down

MODEL	KX018-4	SPECIFICATION	CAB VERSION
	KBM	STANDARD TRACK WIDTH	ARM 1090 mm

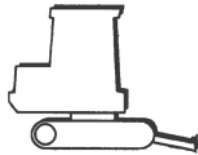
LIFT POINT HEIGHT [mm]	Lift point radius (mm)								kN (t)		
	Minimum	1500	2000	2500	3000	Maximum					
4000											
3500											
3000											
2500					2.5 (0.26)						
2000					2.4 (0.24)						
1500				2.5 (0.25)	2.7 (0.28)	2.7 (0.28)					
1000			6.2 (0.63)	4.1 (0.42)	3.3 (0.34)	2.9 (0.30)	2.6 (0.27)				
500					5.3 (0.54)	3.8 (0.39)	3.0 (0.31)				
0				5.8 (0.59)	5.5 (0.56)	3.9 (0.40)	2.9 (0.30)				
-500			5.6 (0.57)	7.6 (0.78)	5.1 (0.52)	3.6 (0.37)	2.6 (0.27)				
-1000			8.7 (0.89)	6.5 (0.66)	4.3 (0.44)	3.1 (0.32)					
-1500		10.9 (1.11)	5.0 (0.51)	3.2 (0.33)							
-2000											
-2500											

Please observe the model name on the type plate (page 41).

Lifting capacity over front end, dozer down

MODEL	KX019-4	SPECIFICATION	CANOPY VERSION, UNLADEN WEIGHT 1680 kg
	KBM	STANDARD TRACK WIDTH	ARM 1190 mm

kN (t)

LIFT POINT HEIGHT [mm]	Lift point radius (mm)											
			Mini-mum	1500	2000	2500	3000	3500	Maxi-mum			
4000												
3500												
3000												
2500						2.1 (0.21)						
2000						2.2 (0.22)	2.5 (0.26)					
1500					2.4 (0.24)	2.6 (0.27)	2.6 (0.27)					
1000					4.2 (0.43)	3.3 (0.34)	2.9 (0.30)	2.5 (0.26)	2.5 (0.26)			
500					5.5 (0.56)	3.9 (0.40)	3.0 (0.31)	2.5 (0.25)				
0				5.4 (0.55)	5.7 (0.58)	4.0 (0.41)	3.0 (0.31)	2.4 (0.24)				
-500			5.3 (0.54)	7.7 (0.79)	5.2 (0.53)	3.8 (0.39)	2.8 (0.29)					
-1000			7.8 (0.80)	6.8 (0.69)	4.5 (0.46)	3.3 (0.34)	2.4 (0.24)					
-1500			11.0 (1.12)	5.5 (0.56)	3.6 (0.37)	2.5 (0.26)						
-2000												
-2500												

Lifting capacity over front end, dozer down

MODEL	KX019-4	SPECIFICATION	CAB VERSION, UNLADEN WEIGHT 1780 kg
	KBM	STANDARD TRACK WIDTH	ARM 1190 mm

kN (t)

LIFT POINT HEIGHT [mm]	Lift point radius (mm)											
			Mini-mum	1500	2000	2500	3000	3500	Maxi-mum			
4000												
3500												
3000												
2500						2.0 (0.20)						
2000						2.1 (0.21)	2.4 (0.24)					
1500					2.3 (0.23)	2.5 (0.26)	2.5 (0.26)					
1000					4.0 (0.41)	3.2 (0.33)	2.7 (0.28)	2.4 (0.24)	2.4 (0.24)			
500					5.2 (0.53)	3.7 (0.38)	2.9 (0.30)	2.4 (0.24)				
0				5.1 (0.52)	5.4 (0.55)	3.8 (0.39)	2.9 (0.30)	2.3 (0.23)				
-500			5.0 (0.51)	7.4 (0.75)	5.0 (0.51)	3.6 (0.37)	2.7 (0.28)					
-1000			7.5 (0.76)	6.5 (0.66)	4.3 (0.44)	3.1 (0.32)	2.3 (0.23)					
-1500			10.5 (1.07)	5.2 (0.53)	3.4 (0.35)	2.5 (0.25)						
-2000												
-2500												

Please observe the model name on the type plate (page 41).

Lifting capacity of the excavator

Lifting capacity over front end, dozer down

MODEL	KX019-4SF	SPECIFICATION	CANOPY VERSION, UNLADEN WEIGHT 1675 kg
	KBM	STANDARD TRACK WIDTH	ARM 1090 mm

LIFT POINT HEIGHT [mm]	Lift point radius (mm)										kN (t)		
			Minimum	1500	2000	2500	3000	3500	Maximum				
GL	4000												
	3500												
	3000												
	2500						2.6 (0.27)						
	2000						2.5 (0.25)						
	1500					2.5 (0.26)	2.8 (0.29)	2.8 (0.29)					
	1000				6.5 (0.66)	4.3 (0.44)	3.5 (0.36)	3.0 (0.31)	2.5 (0.26)				
	500					5.6 (0.57)	4.0 (0.41)	3.1 (0.32)					
	0				6.1 (0.62)	5.8 (0.59)	4.1 (0.42)	3.1 (0.32)					
	-500			5.9 (0.60)	7.9 (0.81)	5.3 (0.54)	3.8 (0.39)	2.8 (0.29)					
	-1000			9.1 (0.93)	6.8 (0.69)	4.5 (0.46)	3.2 (0.33)						
	-1500			11.4 (1.16)	5.2 (0.53)	3.4 (0.35)							
	-2000												
-2500													

Lifting capacity over front end, dozer down

MODEL	KX019-4 SF	SPECIFICATION	CAB VERSION, UNLADEN WEIGHT 1775 kg
	KBM	STANDARD TRACK WIDTH	ARM 1090 mm

LIFT POINT HEIGHT [mm]	Lift point radius (mm)										kN (t)		
			Minimum	1500	2000	2500	3000	3500	Maximum				
GL	4000												
	3500												
	3000												
	2500						2.5 (0.26)						
	2000						2.4 (0.24)						
	1500					2.5 (0.25)	2.7 (0.28)	2.7 (0.28)					
	1000				6.2 (0.63)	4.1 (0.42)	3.3 (0.34)	2.9 (0.30)	2.5 (0.25)				
	500					5.3 (0.54)	3.8 (0.39)	3.0 (0.31)					
	0				5.8 (0.59)	5.5 (0.56)	3.9 (0.40)	2.9 (0.30)					
	-500			5.6 (0.57)	7.6 (0.78)	5.1 (0.52)	3.6 (0.37)	2.6 (0.27)					
	-1000			8.7 (0.89)	6.5 (0.66)	4.3 (0.44)	3.1 (0.32)						
	-1500			10.9 (1.11)	5.0 (0.51)	3.2 (0.33)							
	-2000												
-2500													

Please observe the model name on the type plate (page 41).

Accessories

The accessories approved for this excavator by the respective countries are described in the following segments. For further accessories, please contact your KUBOTA dealer or authorized retailer.



Accessories from other manufacturers may only be fitted after prior written approval from KUBOTA. Also see the "Approved use" section (page 15).

KUBOTA Rotary beacon

An optional rotary beacon (1) is available as an accessory. The beacon is mounted at the rear end of the canopy and/or cab roof with a clip-on pedestal (2).

The rotary beacon is switched on and off with the rotary beacon switch. See the "Right control console" section (page 46) for details.

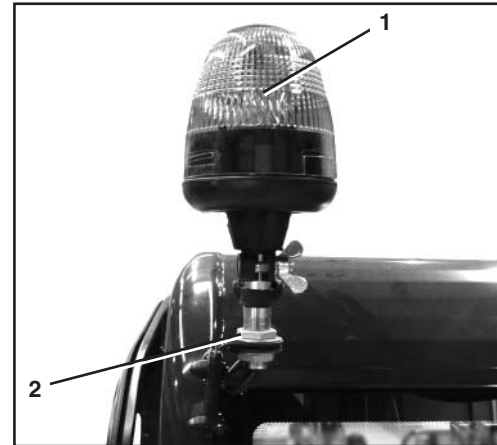

KUBOTA Pipe safety valve

The pipe safety valve prevents the load from suddenly lowering during lifting operation in case a pipe or hose bursts.

The pipe safety valve is attached directly to the hydraulic port of the boom cylinder (2), arm cylinder (1) or dozer cylinder (3).

Excavators that will be used in the lifting operation, must be equipped with at least a pipe safety valve on the boom and arm, together with an overload warning function according to EN 474-5. An additional pipe safety valve in accordance with EN 474-1 must be installed before using the dozer for lifting operation support.

To equip the excavator for the lifting operation, contact your KUBOTA specialist dealer.

The pipe safety valve is adjusted in the factory on the particular excavator.

Manipulating the pipe safety valve will void the warranty.

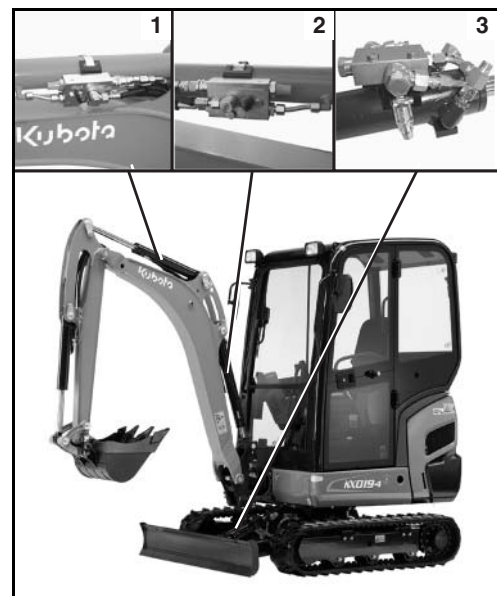

Any manipulation can result in substantial personal injuries, even death, and is therefore strictly forbidden.

The manipulation and repair of the pipe safety valves is forbidden. They may only be replaced by your KUBOTA dealer as a kit.

Accessories

Note on use

- Check the pipe safety valve lead seal before using the excavator. Do not carry out any excavating work if the lead seal is missing and/or the pipe safety valve is damaged.
- It is not allowed to swing the boom during lifting operation.
-

KUBOTA Overload warning function

An overload warning function informs the operator immediately if there is an overload. The warning system is controlled by the pressure switch at the pipe safety valve. The load is measured by the pressure at the base of the cylinder. Any overpressure triggers the warning device.

The warning device is activated with the warning device rocker switch (1). In the event of an overload, an acoustic signal sounds and the warning light (2) flashes.

Excavators that will be used in the lifting operation, must be equipped with at least a pipe safety valve on the boom and arm, together with an overload warning function according to EN 474-5. An additional pipe safety valve in accordance with EN 474-1 must be installed before using the dozer for lifting operation support.

To equip the excavator for the lifting operation, contact your KUBOTA specialist dealer.

When changing from rubber crawlers to steel crawlers, or from steel crawlers to rubber crawlers, or when modifying the length of the arm, please contact your KUBOTA dealer.

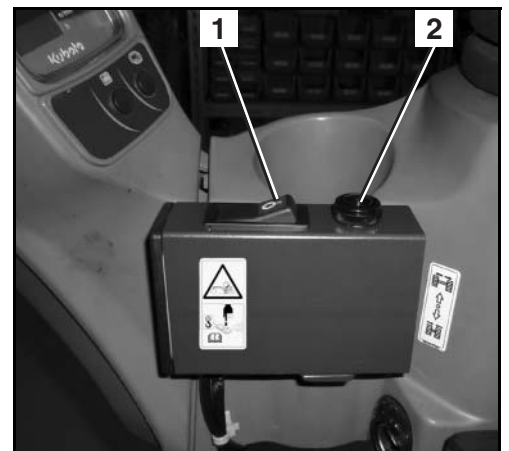

The overload warning function must be enabled during any lifting operation to prevent personal injuries and damage to equipment.

KUBOTA Gravel guard

The gravel guard is a protective grid which protects the operator against objects falling down or being thrown up.

The gravel guard is bolted onto the mounting points (see arrows) at the canopy or the cabin.

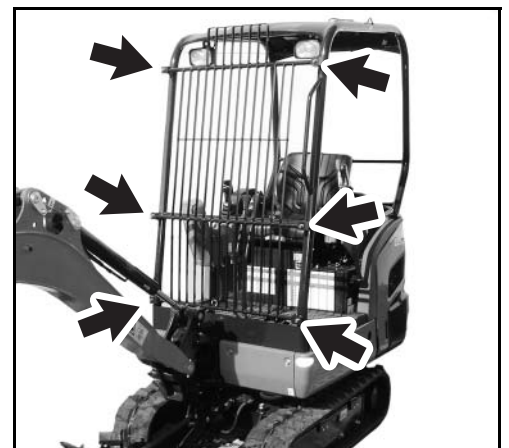

KUBOTA Quick coupling systems and equipments

The quick coupling system is designed to be mounted with pins at the arm and the bucket linkage. It is designed to receive KUBOTA bucket accessories only.

The related operating instructions are attached to the excavator's operating instructions.

For further information, please contact your KUBOTA dealer or authorized retailer.



The size, weight and arm bracket of the excavator are important factors in the selection of attachments. These factors must be made known to the attachment manufacturer when ordering attachments, and be observed by the operator when operating the excavator. Various attachments are nevertheless of limited use only.

KUBOTA Bucket accessories

For further bucket accessories, please contact your KUBOTA dealer or authorized retailer.

KUBOTA Foot pedal kit

The foot pedal kit (1) allows the operator to foot-control the drive levers (2). The functions of the left and/or right foot pedal correspond to the left and/or right drive levers (page 45).



To operate the foot pedals, tilt the pedal extensions (3) to the back. After use, or for maximum freedom of movement in the foot area, tilt the pedal extensions to the front.

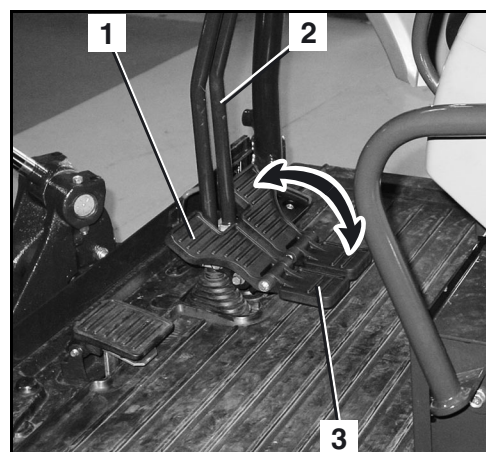

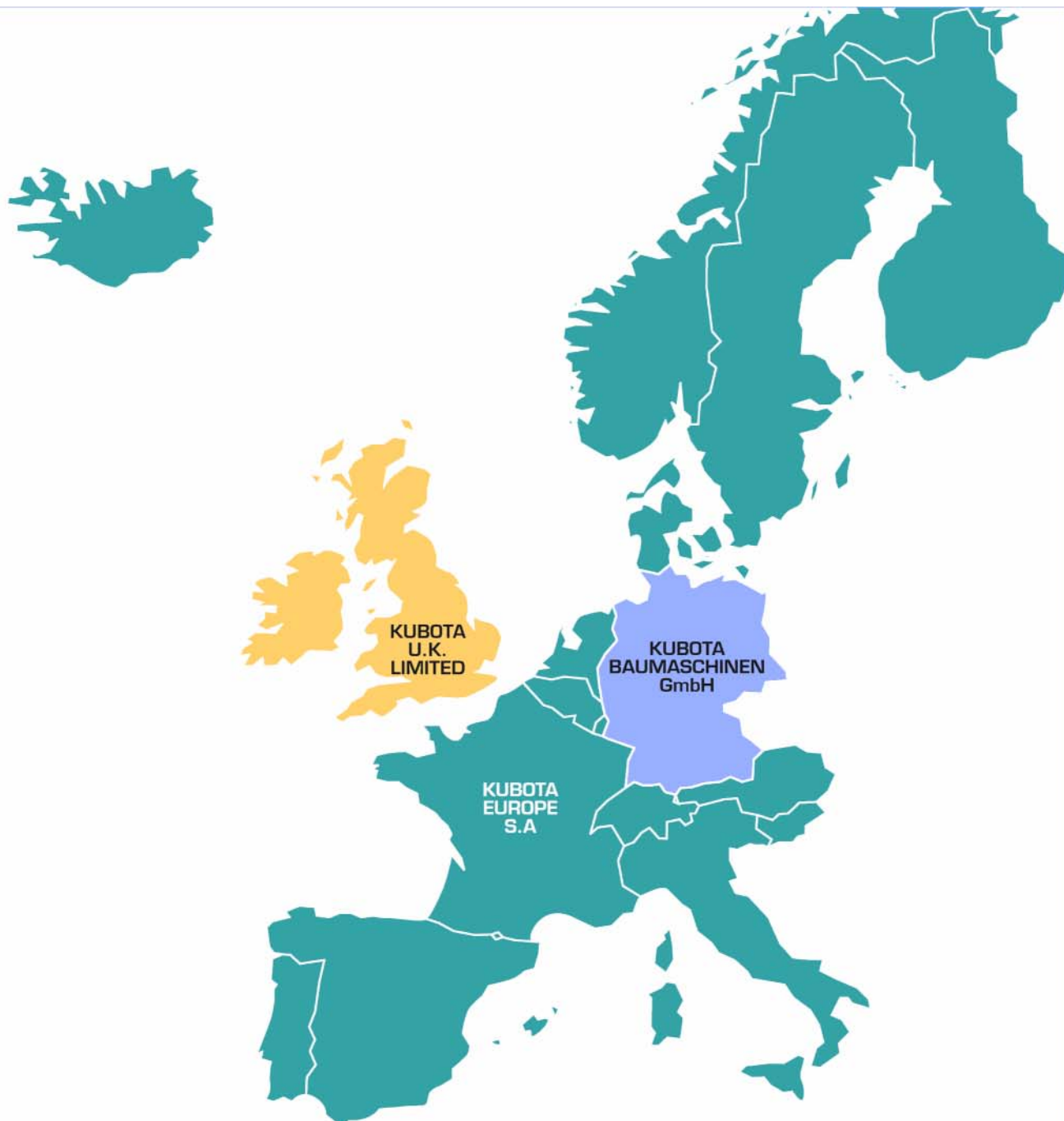

KUBOTA EUROPE S.A.

19-25, rue Jules Verne - BP 50088, Z.I.
95101 Argenteuil Cedex France
Tel. +33 (0)1 34 26 34 34 - Fax. +33 (0)1 34 26 34 21
www.kubota.fr

KUBOTA BAUMASCHINEN GmbH

Steinhauser Straße 100
66482 Zweibrücken
Tel. : +49 (0)6332 48 70 - Fax : +49 (0)6332 48 71 01
www.kubota-baumaschinen.de

KUBOTA U.K. LIMITED

Dormer Road, Thame Oxfordshire, OX9 3UN
Phone : +44 (0)184 421 4500 - Fax : +44 (0)184 421 6685
www.kubota.co.uk