

Operation and Maintenance Manual

71H Pipelayer for D6N LGP

S/N 043050040021- UP (Sideboom)

**TO BE USED WITH CATERPILLAR
D6N LGP OEM SC600100-UP TRACTOR OPERATION AND MAINTENANCE MANUALS**

**VANGUARD EQUIPMENT, INC.
15627 EAST PINE ST
TULSA, OKLAHOMA
74116, USA**

: 918.437.1796

: 918.437.1794

Table of Contents

FOREWORD	1
LITERATURE INFORMATION	1
MACHINE DESCRIPTION	1
SAFETY	1
OPERATION	1
MAINTENANCE	2
MAINTENANCE INTERVALS	2
MACHINE CAPACITY	2
SAFETY SECTION	3
SAFETY MESSAGES – 71H PIPELAYER.....	3
<i>Do Not Operate (1)</i>	5
<i>Tipover Hazard (2)</i>	5
<i>Free Fall Active - Do Not Operate (3)</i>	6
<i>Counterweight Lock Lever Thrown or Flying Objects – Full Body Exposure (4)</i>	6
<i>Counterweight Crushing Hazard (5)</i>	7
<i>Counterweight Crushing Hazard (6)</i>	7
<i>Hydraulic Accumulator (7, 8)</i>	8
<i>Electrical Power Lines (9)</i>	9
<i>Boom Stop Operation and Adjustment - Do Not Operate (10)</i>	9
<i>Not a Tow Point (11)</i>	10
BEFORE OPERATION	10
VISIBILITY INFORMATION.....	10
OPERATION	11
<i>Machine Operating Temperature Range</i>	11
<i>Machine Operation</i>	11
<i>Lifting Capacities</i>	12
<i>Limitations on Lifting Loads That Exceed the Working Range</i>	12
<i>Electrical Power Lines</i>	13
<i>Parking</i>	13
<i>Slope Operation</i>	14
<i>Equipment Lowering with Engine Stopped</i>	15
<i>Sound Information and Vibration Information</i>	15
<i>Sound Level Information</i>	15
<i>"The European Union Physical Agents (Vibration) Directive 2002/44/EC"</i>	15
<i>Guards</i>	15
PRODUCT INFORMATION SECTION.....	16
GENERAL INFORMATION	16
<i>Components</i>	16
<i>Specifications</i>	17
<i>Intended Use</i>	17
<i>Restrictions to Application and Configuration</i>	17
LIFTING CAPACITIES	18
OPERATION SECTION	19
BEFORE OPERATION	19
<i>Mounting and Dismounting</i>	19
<i>Daily Inspection</i>	20
<i>Daily Checks</i>	21
TRACTOR OPERATION	21
<i>Hydraulic Oil Temperature</i>	21
PIPELAYER OPERATION	22
<i>Speed/Lockout Control Lever(1)</i>	22
<i>Speed/Lockout Control Lock (2)</i>	23
<i>Hook Control (3)</i>	23
<i>Accumulator - Relieving Charge</i>	24
<i>Boom Control (4)</i>	24
<i>Boom Stop Valve</i>	24
<i>Counterweight Control (5)</i>	24

Counterweight Control-Lockout Lever (6).....	24
Throttle control switch & Operator Heater switch (7).....	25
Horn location moved (8).....	25
Counterweight Lock Lever.....	25
Equipment Lowering with Engine Stopped.....	27
Machine Warm-Up.....	28
TRANSPORTATION INFORMATION.....	29
Shipping the Machine.....	29
Lifting and Tying Down the Machine.....	30
TOWING INFORMATION.....	31
REMOVAL OF THE BOOM.....	32
MAINTENANCE AND LUBRICATION SECTION.....	34
LUBRICANT VISCOSITIES - GENERAL.....	34
SELECTING THE VISCOSITY.....	34
<i>Lubricant Viscosities for Ambient Temperatures.....</i>	35
LUBRICANT CAPACITIES (REFILL).....	35
S-O-S INFORMATION.....	36
MAINTENANCE INTERVAL SCHEDULE (MIS).....	36
SERVICE INTERVALS.....	36
WHEN REQUIRED.....	36
<i>Every 10 Service Hours or Daily.....</i>	36
<i>Every 50 Service Hours or Weekly.....</i>	36
<i>Every 500 Service Hours.....</i>	37
<i>Every 500 Service Hours or 3 Months.....</i>	37
<i>Every 1000 Service Hours or 6 Months.....</i>	37
<i>Every 2000 Service Hours or 1 Year.....</i>	37
ACCUMULATOR.....	37
BOOM STOP VALVE OPERATION AND ADJUSTMENT.....	39
BOOM LINE – INSTALL.....	40
BOOM PIVOT PINS – LUBRICATE.....	42
COUNTERWEIGHT CYLINDER BEARINGS – LUBRICATE.....	42
COUNTERWEIGHT HINGE PINS - LUBRICATE.....	44
FAIRLEAD SHEAVE – LUBRICATE.....	45
HOOK AND WIRE CABLE – INSPECT.....	45
<i>Inspect the Hook.....</i>	45
<i>Inspect Wire Cable - Boom and Hook lines.....</i>	46
HOOK LOAD LINE – INSTALL.....	47
HOOK WINCH: FREEFALL, BRAKE, GEARBOX OIL - CHANGE.....	50
BOOM WINCH: FREEFALL, BRAKE, GEARBOX OIL - CHANGE.....	51
HYDRAULIC SYSTEM OIL - CHANGE.....	52
HYDRAULIC SYSTEM OIL FILTER - REPLACE.....	56
HYDRAULIC SYSTEM OIL LEVEL – CHECK.....	57
HYDRAULIC SYSTEM OIL SAMPLING.....	58
OIL FILTER INSPECTION.....	58
SHEAVE BLOCK BEARING - LUBRICATE.....	59
TRACTOR MAINTENANCE.....	60
APPENDIX - TERMINATOR INSTRUCTIONS.....	61

Foreword

Literature Information

This manual should be stored in the operator's compartment in the literature holder or seat back literature storage area.

This manual contains safety information, operation instructions, transportation information, lubrication information and maintenance information.

The information contained in this manual is limited to the pipelayer components and specific modifications made to the tractor unit, refer to the CATERPILLAR Tractor Operation and Maintenance Manual for complete information regarding the tractor unit.

Some photographs or illustrations in this publication show details or attachments that can be different from your machine. Guards and covers might have been removed for illustrative purposes.

Continuing improvement and advancement of product design might have caused changes to your machine which are not included in this publication. The latest version of this publication is available for download from the internet at vanguardequip.com. Read, study and keep this manual with the machine.

Whenever a question arises regarding your machine, or this publication, please consult Vanguard Equipment for the latest available information.

Machine Description

The sideboom equipment is attached to a Caterpillar D6N LGP tractor. The primary use of this machine is for petroleum-product pipeline-construction in the 16" to 24" (405 to 610 mm) pipeline range.

The operator should read, understand, and follow both the tractor and the pipelayer operating and maintenance instructions. The operator must comply with all pipelayer procedures, regulations, and safety precautions.

This equipment is to be operated by qualified personnel only.

This equipment is to be serviced and maintained by qualified personnel only.

The daily service/inspection procedure should be performed before start-up.

Operate all pipelayer controls with no load, until familiar with machine operation.

Note: Refer to the Caterpillar operation manual for detailed information on the specific operation of the tractor unit.

Safety

The safety section lists basic safety precautions. In addition, this section identifies the text and locations of warning signs and labels used on the machine.

Read and understand the basic precautions listed in the safety section before operating or performing lubrication, maintenance and repair on this machine.

NOTICE

Other safety precautions related to the operation of the tractor also apply.
Refer to CATERPILLAR Tractor Operation and Maintenance manual, Safety Section.

Operation

The operation section is a reference for the new operator and a refresher for the experienced operator. This section includes a discussion of gauges, switches, pipelayer controls, transportation and towing information.

Photographs and illustrations guide the operator through correct procedures of checking, starting, operating and stopping the machine.

Operating techniques outlined in this publication are basic. Skill and techniques develop as the operator gains knowledge of the machine and its capabilities.

Maintenance

The maintenance section is a guide to equipment care. The Maintenance Interval Schedule (MIS) lists the items to be maintained at a specific service interval. Items without specific intervals are listed under the "When Required" service interval. The Maintenance Interval Schedule lists the page number for the step-by-step instructions required to accomplish the scheduled maintenance. Use the Maintenance Interval Schedule as an index or "one safe source" for all maintenance procedures.

Maintenance Intervals

Use the service hour meter to determine servicing intervals. Calendar intervals shown (daily, weekly, monthly, etc.) can be used instead of service hour meter intervals if they provide more convenient servicing schedules and approximate the indicated service hour meter reading. Recommended service should always be performed at the interval that occurs first. Under extremely severe, dusty or wet operating conditions, more frequent lubrication than is specified in the maintenance intervals chart might be necessary. Perform service on items at multiples of the original requirement. For example, at every 500 service hours or 3 months, also service those items listed under every 250 service hours or monthly and every 10 service hours or daily.

Machine Capacity

Additional attachments or modifications may exceed machine design capacity which can adversely affect performance characteristics. Included would be stability and system certifications such as brakes, steering, and rollover protective structures (ROPS). Contact your Caterpillar dealer for further information.

Safety Section

Certain conditions and precautions are peculiar to pipelaying operations. The following represents the minimum considerations for safe operations.

NOTICE

Other safety precautions related to the operation of the tractor also apply.
Refer to CATERPILLAR Tractor Operation and Maintenance manual, Safety Section.

Safety Messages – 71H Pipelayer

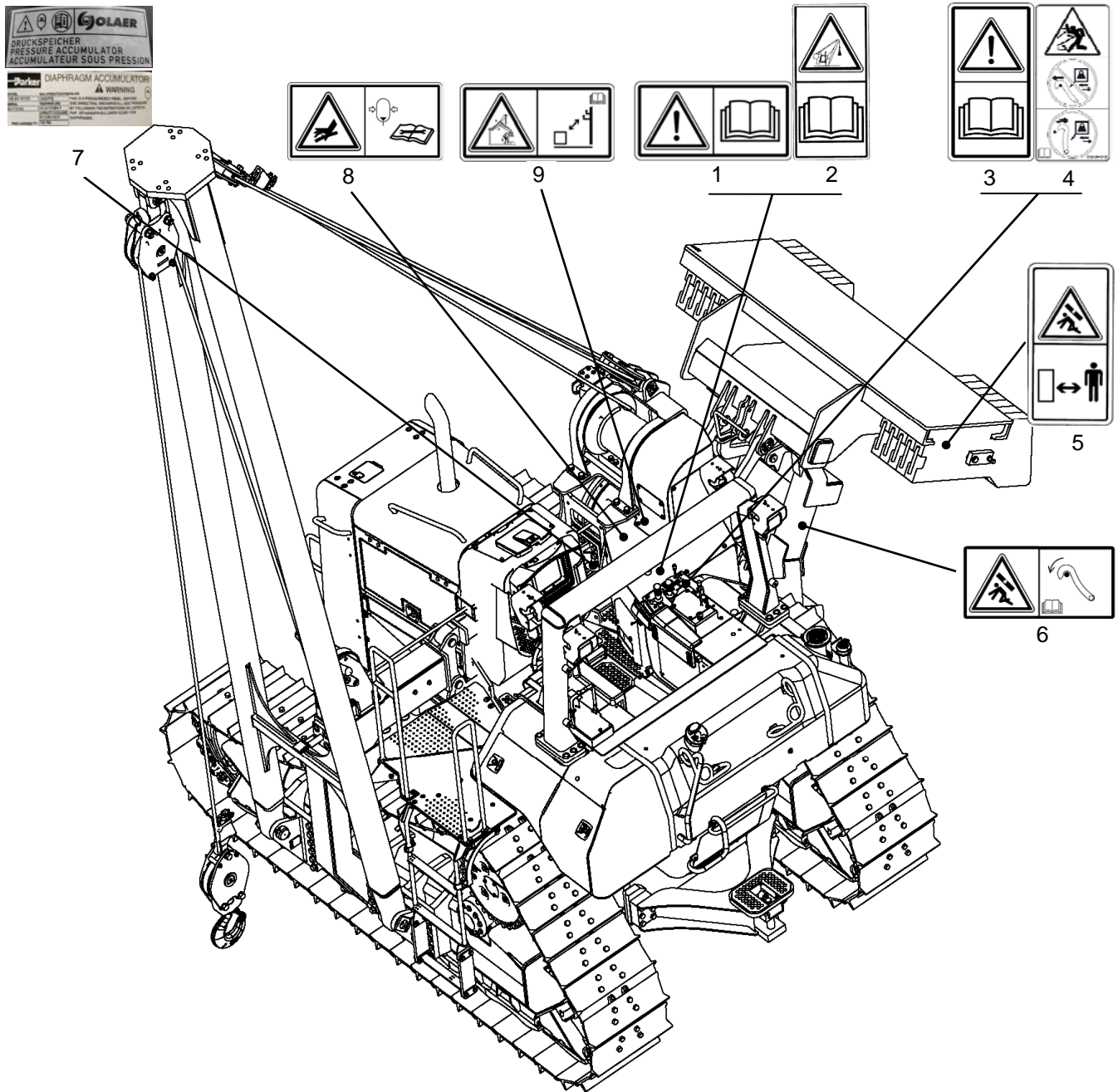

Figure 1: Safety Messages 71H Pipelayer

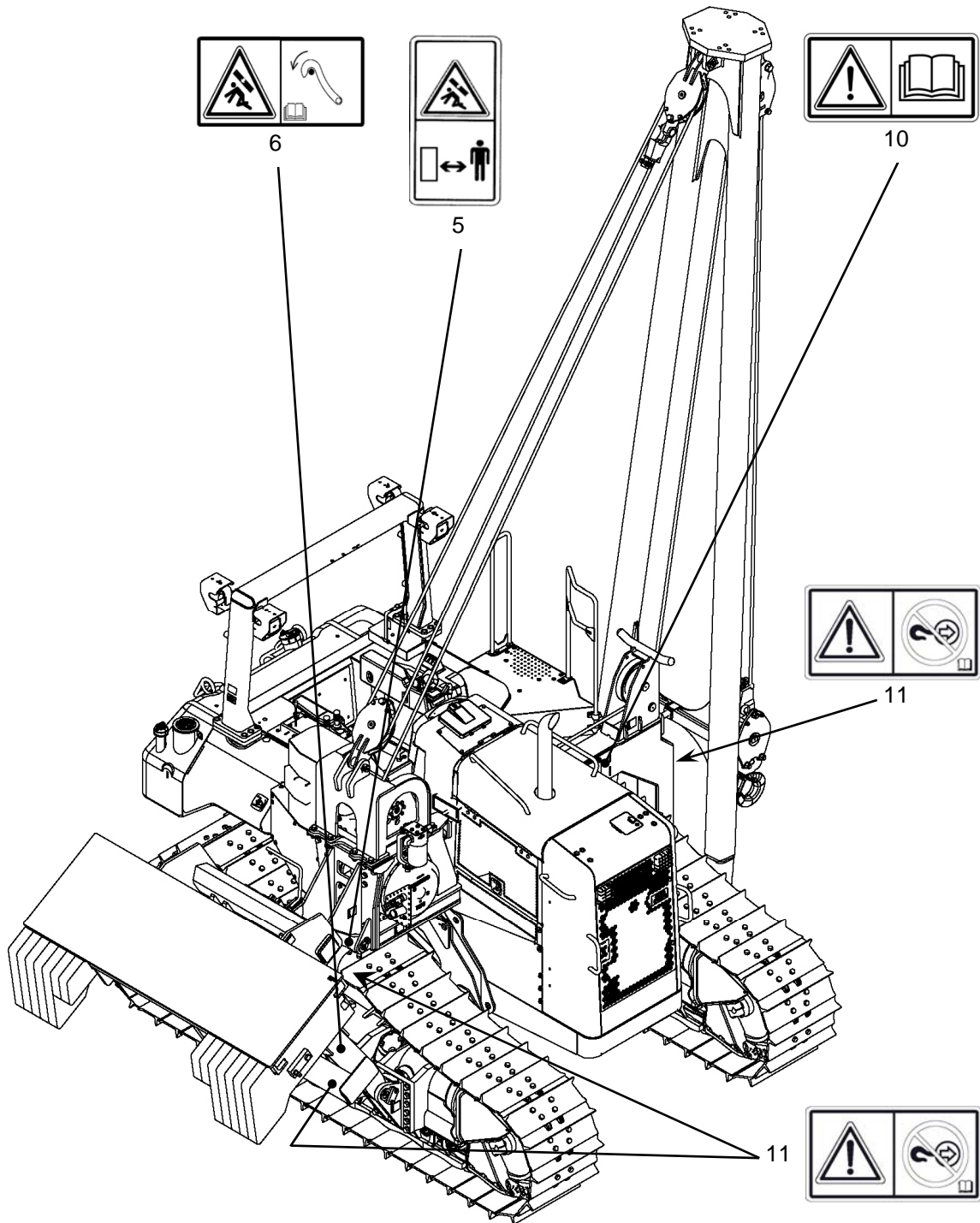

Figure 2: Safety Messages 71H Pipelayer

There are several specific safety messages on this machine. The exact location of the hazards and the description of the hazards are reviewed in this section. Please become familiarized with all safety messages.

Make sure that all of the safety messages are legible. Clean the safety messages or replace the safety messages if you cannot read the words. Replace the illustrations if the illustrations are not visible. When you clean the safety messages, use a cloth, water, and soap. Do not use solvent, gasoline, or other harsh chemicals to clean the safety messages. Solvents, gasoline, or harsh chemicals could loosen the adhesive that secures the safety messages. Loose adhesive will allow the safety message to fall. Do not use pressure washers to clean the warning signs.

Replace any safety message that is damaged or missing. If a safety message is attached to a part of the machine that is replaced, install a safety message on the replacement part.

Do Not Operate (1)



Do not operate or work on this machine unless you have read and understand the instructions and warnings in the Operation and Maintenance Manuals. Failure to follow the instructions or heed the warnings could result in injury or death. Contact your dealer for replacement manuals. Proper care is your responsibility.

Safety message (1) is located on the outside of the right hand operator console arm rest, in front of the pipelayer controls.



Figure 3: Do not operate (1)

Tipover Hazard (2)



The machine may tip and personal injury may occur if the maximum load capacities are exceeded. Load capacities assume that the machine is stationary on a level concrete surface with the counterweight extended. Lift capacities will decrease on slopes or soft ground. See Operation and Maintenance Manual "Lifting Capacities".

Safety message (2) is located on the right hand side, on the upper winch guarding, facing rear.

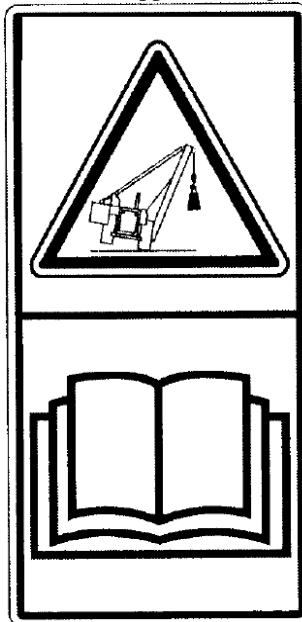

Figure 4: Tipover Warning (2)

Free Fall Active - Do Not Operate (3)



Dropping load hazard! The free fall control remains live for several hours after the engine has been stopped. Operation of the free fall control could cause a sudden uncontrolled drop of any supported load. Do not operate the free fall control when personnel are near a suspended load, even with the engine stopped. See Operation and Maintenance Manual "Pipelayer Operation" for complete description of control operation.

Safety message (3) is located on the right side, on the pipelayer control box.

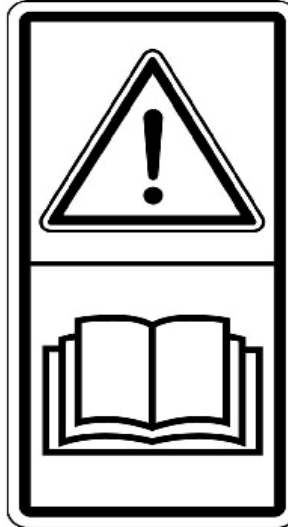

Figure 5: Free fall active warning (3)

Counterweight Lock Lever Thrown or Flying Objects – Full Body Exposure (4)



Thrown or flying objects - full body exposure! Do not operate counterweight while the counterweight lock lever is engaged. Retracting the counterweight while the lock lever is engaged could cause serious equipment damage, personnel injury, or even death. Ensure the counterweight lock lever is fully disengaged before retracting the counterweight.

Safety message (4) located on the right side, near the counterweight control.



Figure 6: Thrown or flying objects - counterweight lock lever instruction (4)

Counterweight Crushing Hazard (5)



Crushing Hazard! Be sure no one is under or near the counterweight before lowering the counterweight. When the counterweight is in the fully extended position for servicing the machine, secure the extended counterweight with the counterweight lock lever. Use the counterweight lock lever to avoid possible personnel injury or death from crushing. Keep all personnel away from the counterweight when lowering the counterweight to avoid possible personnel injury or death.

Safety message (5) is located on the front and rear sides of the counterweight frame, and on the front and rear counterweight arms.



Figure 7: Counterweight crushing hazard and pinch point (5)

Counterweight Crushing Hazard (6)



Crushing Hazard! When the counterweight is in the fully extended position for servicing the machine, secure the extended counterweight with the counterweight lock lever. Use the counterweight lock lever to avoid possible personnel injury or death from crushing.

Use the lock to secure the counterweight when the machine is serviced. Refer to Operation and Maintenance Manual, "Counterweight Lock Lever" for details.

Safety message (6) is located on the front and rear sides of the Counterweight arm.



Figure 8: Counterweight crushing hazard, use lock lever (6)

Hydraulic Accumulator (7, 8)



High Pressure Cylinder: Rapid discharging from disconnecting or disassembly or failure to follow the instructions and warnings could cause an explosion, resulting in possible injury or death. Do not expose to fire. Do not weld. Do not drill. Do not remove any hydraulic system lines, taps or parts until pressure has been relieved. Relieve pressure before discharging. See Operation and Maintenance Manual "Accumulator" for charging and discharging. See your Dealer for tools and detailed information. Precharge only with dry nitrogen gas.

Safety message (7) is attached to the hydraulic accumulator. The hydraulic accumulator is located on the right side of the operator seat, on the winch base to the left of the hook winch.



Figure 9: Hydraulic accumulator (7)

Safety message (8) is located outside of the right hand operator console arm rest, in front of the pipelayer controls.

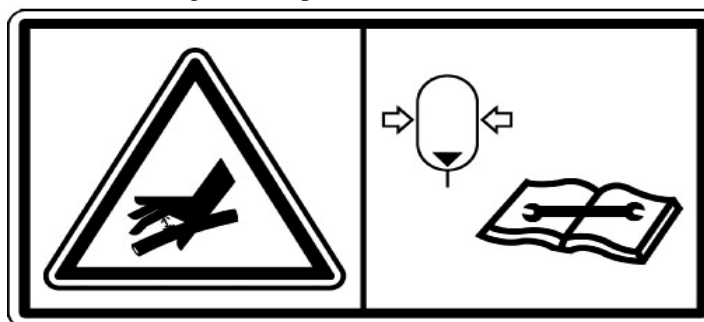

Figure 10: System equipped with an accumulator (8)

Electrical Power Lines (9)



Electrocution Hazard! Keep the machine and attachments a safe distance from electrical power. Stay clear 3 M (10 ft) plus twice the line insulator length. Read and understand the instructions and warnings in the Operation and Maintenance Manual. Failure to follow the instructions and warnings will cause serious injury or death.

Safety message (9) is located on the right hand side, on the upper winch guarding, facing left.

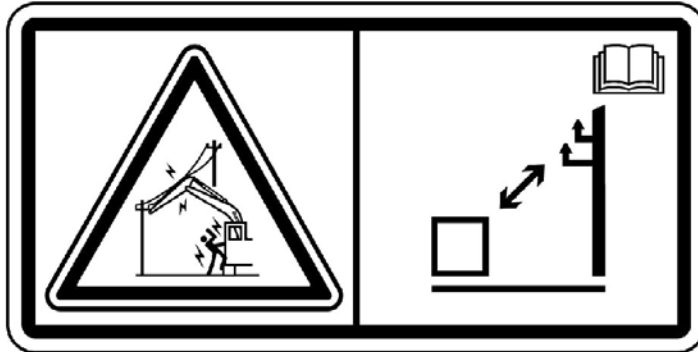

Figure 11: Electrical power lines (9)

Boom Stop Operation and Adjustment - Do Not Operate (10)



The Boom Stop system stops the boom winch from hauling-in when the boom is vertical, preventing overloading of key machine components. Defeating the boom stop valve could result in serious equipment damage, personnel injury, or even death. The boom stop function must be check and verified daily, Do not Operate until it has been checked and properly adjusted. See the Operation and Maintenance Manual "Boom Stop Valve".

Safety message (10) is located on the left hand frame at the front, on the boom stop valve access panel.



Figure 12: Boom stop valve (10)

Not a Tow Point (11)



Equipment Damage Hazard! Do not use pipelayer structures or components for towing purposes of any kind. Only used designated tractor tow points for towing purposes. Refer to Operation and Maintenance Manual, "Towing Information" for details. Failure to follow the instructions and warnings could result in structural damage which cause serious injury or death.

Safety message (11) is located on the left side of the Left Hand Frame, on the front side of the Right Hand Frame, and on the lower cross-tube of the Counterweight swing frame..



Figure 13: Counterweight crushing hazard, use lock lever (6)

Before Operation

Clear all personnel from the machine and from the area.

Remove all obstacles from the path of the machine. Beware of hazards such as wires, ditches, etc.

Make sure that the machine horn, the backup alarm (if equipped) and all other warning devices are working properly.

Reference: Refer to Operation and Maintenance Manual, "Daily Inspection" in this manual and in the Tractor's manual.

Fasten the seat belt securely.

Visibility Information

Before starting the machine, the operator shall perform a walk-around inspection in order to ensure that there are no hazards around the machine.

While the machine is in operation, the operator should constantly survey the area around the machine. The operator needs to identify potential hazards as a hazard becomes visible around the machine.

Your machine may be equipped with mirrors or other visual aids. An example of a visual aid is Closed Circuit Television (CCTV). The operator should ensure that the visual aids are in proper working condition and that the visual aids are clean. Adjust the visual aids for the best visibility of all areas around the machine. Refer to the specific tractor Operation and Maintenance Manual.

It may not be possible to provide direct visibility on large machines to all areas around the machine. Appropriate job site organization is required in order to minimize hazards that are caused by restricted visibility. Job site organization is a collection of rules and procedures that coordinates machines and people that work together in the same area.

The operator is required to survey his/her field of vision when operating the machine.

Both the right-hand overhead mirror, and the right-hand side view mirror shall be adjusted so that a person walking 1m (3 ft 3 in) to the right of the machine, can be seen in a length of at least 200mm (7.9 in) either directly or indirectly all the way down the side of the machine.

The left-hand side view mirrors shall be adjusted so the operator is comfortable with his/her vision to the rear of the machine.

Examples of job site organization include the following:

- Safety instructions
- Controlled patterns of machine movement
- Controlled patterns of vehicle movement
- Restricted areas
- Operator training
- Warning symbols or warning signs on machines or on vehicles
- A system of communication
- Communication between workers and operators prior to approaching the machine

Operation

Machine Operating Temperature Range

The standard pipelayer component configuration is intended for use within an ambient temperature range of -40 °C (-40 °F) to 50 °C (122 °F). Special configurations for different ambient temperatures may be available. Consult your dealer for additional information. Refer to the specific tractor Operation and Maintenance manual for standard tractor capabilities.

Machine Operation

Only operate the machine while you are in a seat. The seat belt must be fastened while you operate the machine. Only operate the controls while the engine is running.

Before you move the machine, make sure that no one will be endangered.

Check for proper operation of all controls and protective devices while you operate the machine slowly in an open area. Do not allow riders on the machine unless the machine has the following equipment:

- additional seat
- additional seat belt

Report any needed repairs that were noted during operation.

Do not go close to the edge of a cliff, an excavation, or an overhang.

If the machine begins to sideslip, turn the machine downhill.

Be careful to avoid any condition which could cause the machine to tip. The machine can tip when you work on hills, banks and slopes. Also, the machine can tip when you cross ditches, ridges or other obstacles.

Whenever it is possible, operate the machine up the slopes and down the slopes. Avoid operating the machine across the slope, when possible.

Keep the machine under control. Do not overload the machine beyond capacity.

Be sure that the towing eyes and towing devices are adequate.

Towing eyes and towing devices should only be used to recover the machine.

Connect trailing equipment to a drawbar or to a hitch only.

When you maneuver the machine to connect equipment, be sure that there are no personnel between the machine and the trailing equipment. Block the hitch of the trailing equipment in order to align the equipment with the drawbar.

Never straddle a wire cable or allow other personnel to straddle a wire cable.

Know the maximum dimensions of your machine.

Lifting Capacities

Maintain control of the machine. Do not overload the machine beyond the machine capacity. Ensure that the correct load chart is referenced. Loads must be within the capabilities of the machine. Lifting capacity decreases as the load is moved further from the machine.

Use lifting slings that are approved and use lifting slings that are load tested. Also, all wire ropes or chains must be properly maintained. The wire ropes and chains must meet local regulations. You must know the load carrying capacity of these devices and you must know the correct use of these devices.

Wire rope limitations, soil conditions, and slope of terrain reduce actual capacity. All lifts must be made with the load line vertical, and the boom centerline directed toward the load.

To prevent cable from slipping off the drum, a minimum of five full-wraps of cable must remain on the winch drum at maximum working extension of the hook or boom.

Limitations on Lifting Loads That Exceed the Working Range

Do not load the boom beyond the maximum load capacity. See Operation and Maintenance Manual, "Lifting Capacities" for the load capacity of the boom.

When the load capacity is exceeded, refer to "American National Standards ANSI/ASME B30.14", or to ISO 8813.

Also, follow the procedures that are listed below:

- Inspect the wire cable for defects prior to the lift operation
- Inspect the wire cable for defects after the lift operation
- Do not exceed the load capacity of the boom
- The load must be handled safely in order to minimize tipping effects
- The lift operation and the inspections must be made under controlled conditions by a competent, authorized person

Electrical Power Lines



Serious injury or death by electrocution can result if the machine or attachments are not kept the proper distance from electrical power lines.

Use the following chart, and refer to ANSI/ASME B30.14-3.4.2 in order to determine the safe distance from high voltage wires during these conditions:

- machine operation
- machine transportation

When Operating Near High Voltage Power Lines	
Normal Voltage (Phase to Phase)	Minimum Clearance Required
0 Volts to 50 kVolts	3.05 Meters (10 Feet)
Over 50 kVolts to 200 kVolts	4.60 Meters (15 Feet)
Over 200 kVolts to 350 kVolts	6.10 Meters (20 Feet)
Over 350 kVolts to 500 kVolts	7.62 Meters (25 Feet)
Over 500 kVolts to 750 kVolts	10.67 Meters (35 Feet)
Over 750 kVolts to 1000 kVolts	13.72 Meters (45 Feet)
While in Transit Near High Voltage Power Lines	
Normal Voltage (Phase to Phase)	Minimum Clearance Required
0 Volts to 0.75 kVolts	1.22 Meters (4 Feet)
Over 0.75 kVolts to 50 kVolts	1.83 Meters (6 Feet)
Over 50 kVolts to 345 kVolts	3.05 Meters (10 Feet)
Over 345 kVolts to 750 kVolts	6.10 Meters (20 Feet)
Over 750 kVolts to 1000 kVolts	7.62 Meters (25 Feet)

Table 1: Power lines, minimum clearance

Parking

Park on a level surface. If you must park on a grade, use blocks to prevent the machine from rolling.

Apply the service brake in order to stop the machine. Move the transmission control lever to NEUTRAL position and move the engine speed switch to the LOW IDLE position. Engage the parking brake.

Lower any load to the ground and fully retract the counterweight.

Refer to the tractor's operation and maintenance manual for the specific procedures regarding engine shut down and/or other implement attachments.

Slope Operation

Machines that are operating safely in various applications depend on these criteria: the machine model, configuration, machine maintenance, operating speed of the machine, conditions of the terrain, fluid levels. The most important criteria are the skill and judgment of the operator.

A well trained operator that follows the instructions in the Operation and Maintenance Manual has the greatest impact on stability. Operator training provides a person with the following abilities: observation of working and environmental conditions, feel for the machine, identification of potential hazards, and operating the machine safely by making appropriate decisions.

When you work on side hills and when you work on slopes, consider the following important points:

Speed of travel - At higher speeds, forces of inertia tend to make the machine less stable.

Roughness of terrain or surface - The machine may be less stable with uneven terrain.

Direction of travel - Avoid operating the machine across the slope. When possible, operate the machine up the slopes and operate the machine down the slopes. Place the heaviest end of the machine uphill when you are working on an incline.

Mounted equipment - Balance of the machine may be impeded by the following components: equipment that is mounted on the machine, machine configuration, weights, and counterweights.

Nature of surface - Ground that has been newly filled with earth may collapse from the weight of the machine.

Surface material - Rocks and moisture of the surface material may drastically affect the machine's traction and machine's stability. Rocky surfaces may promote side slipping of the machine.

Slippage due to excessive loads - This may cause downhill tracks or downhill tires to dig into the ground, which will increase the angle of the machine.

Width of tracks - Narrower tracks further increase the digging into the ground which causes the machine to be less stable.

Implements attached to the drawbar - This may decrease the weight on the uphill tracks. The decreased weight will cause the machine to be less stable.

Height of the working load of the machine -When the working loads are in higher positions, the stability of the machine is reduced.

Operated equipment - Be aware of performance features of the equipment in operation and the effects on machine stability.

Operating techniques - Keep all attachments or pulled loads low to the ground for optimum stability.

Machine systems have limitations on slopes -Slopes can affect the proper function and operation of the various machine systems. These machine systems are needed for machine control on slopes.

Note: Safe operation on steep slopes may require special machine maintenance. Excellent skill of the operator and proper equipment for specific applications are also required. Consult the Operation and Maintenance Manual sections for the proper fluid level requirements and intended machine use.

Note: Refer to the tractor's operation and maintenance manual for further specific requirements for safe operation on steep slopes.

Equipment Lowering with Engine Stopped

Before lowering any equipment with the engine stopped, clear the area around the equipment of all personnel. The procedure will cause immediate, rapid lowering of the load. Wear appropriate personal protective equipment and follow the established procedure in the Operation and Maintenance Manual, "Equipment Lowering with Engine Stopped" in the Operation Section of the manual.

Sound Information and Vibration Information

Sound Level Information

Hearing protection may be needed when the machine is operated with an open operator station and an open cab for extended periods or in a noisy environment. Hearing protection may be needed when the machine is operated with a cab that is not properly maintained, or when the doors and windows are open for extended periods or in a noisy environment.

"The European Union Physical Agents (Vibration) Directive 2002/44/EC"

Refer to the tractor operation and maintenance manual "The European Union Physical Agents (Vibration) Directive 2002/44/EC " for complete information, noting that the Information Concerning Whole Body Vibration Level will not be greater than the typical operating activity values given for dozing.

Guards

There are different types of guards that are used to protect the operator.

A daily inspection of the guards is required in order to check for structures that are bent, cracked or loose. Never operate a machine with a damaged structure.

The operator becomes exposed to a hazardous situation if the machine is used improperly or if poor operating techniques are used. This situation can occur even though a machine is equipped with inappropriate protective guard. Follow the established operating procedures that are recommended for your machine.

Product Information Section

General Information

Components

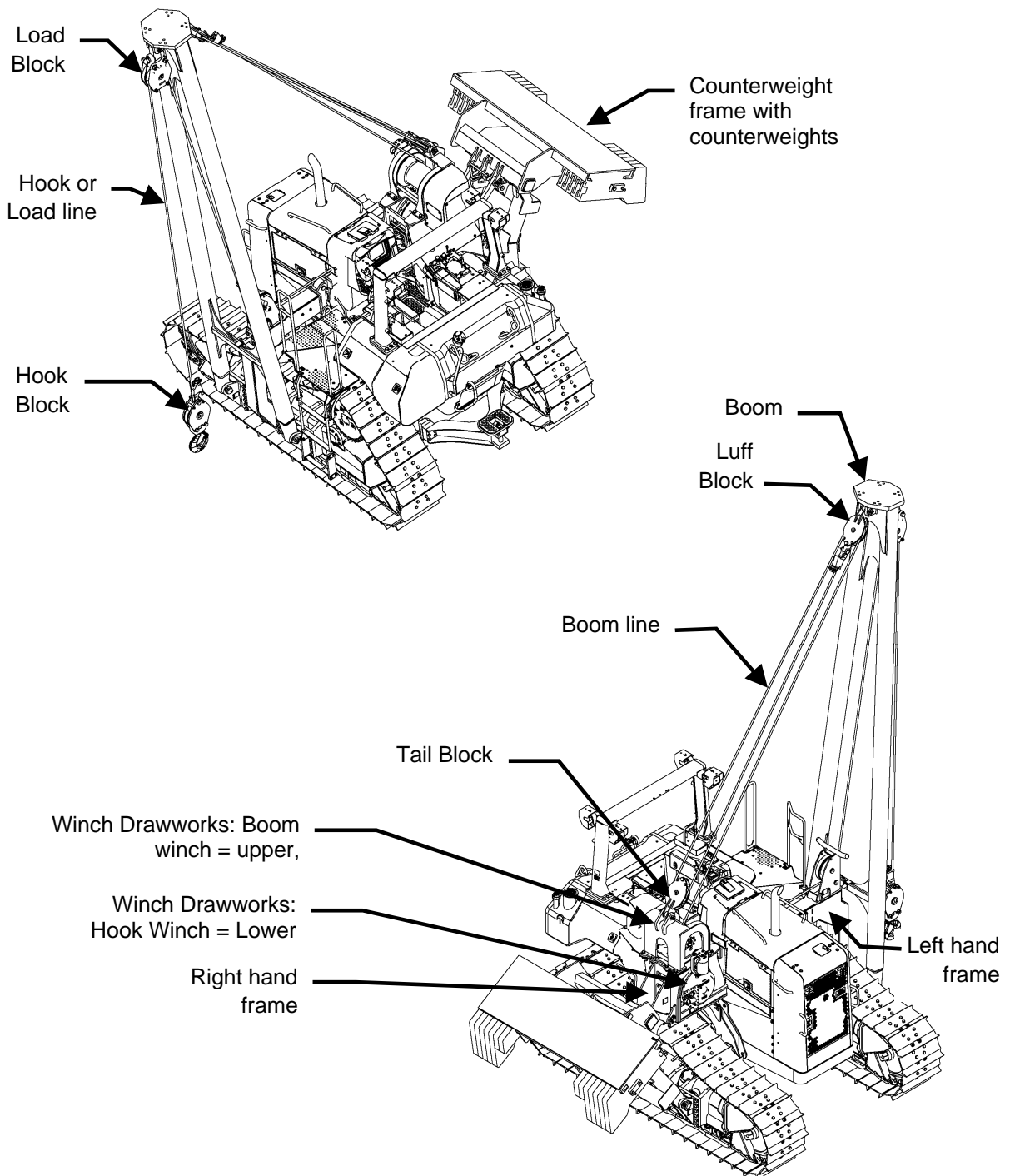

Figure 14: Component identification

Specifications

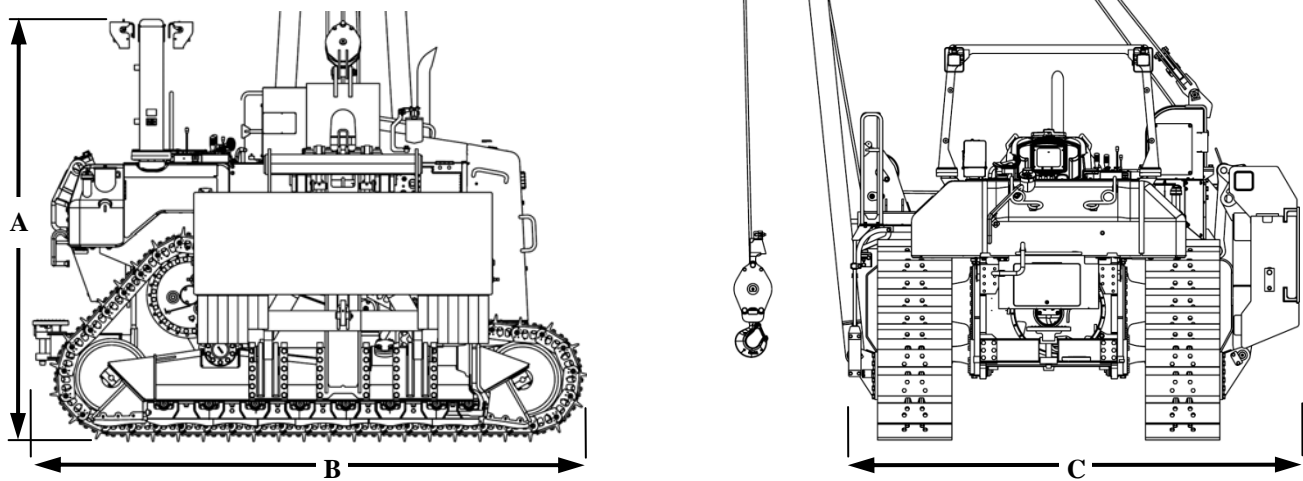

Figure 15: Standard shipping specifications, height and width

71H Pipelayer	
Operating weight of the standard machine¹	21 727 kg (47,900 lb)
Shipping weight of the standard machine²	20 452 kg (45,090 lb)
Weight of the 6.1 m (20 ft) boom	965 kg (2127 lb)
Weight of the boom sheave blocks, the load blocks, and pins	204 kg (450 lb)
Height of the machine without the boom (A)	3200mm (126 in)
Length of the machine (B)	4146 mm (163.2in)
Width of the machine without the boom (C)	3658 mm (144 in)
Height of the machine with the 20 ft boom (per ISO 8813, 1.25 m overhang)	6910mm (272 in)
Ground clearance from ground face of shoe (per SAE)	507 mm (20 in)

Table 2: Specifications

Intended Use

This machine is a Pipelayer that is described in ISO 6165:2012. The machine is intended to perform the following functions: lift, handle, and lay down pipe with a side mounted boom.

Restrictions to Application and Configuration

Maximum approved operating weight is 22 200kg (48,840lb).

The maximum lift capacity per ISO 8813:1992, is 27215 kg (60,000 lb).

The maximum fore and aft slope is 45 degrees or a 100 percent grade for the proper lubrication of the pipelayer components.

Refer to the tractor operation and maintenance manual for additional restrictions.

¹Operating Weight: Includes lubricants, coolant, 100% fuel, hydraulic controls and fluids, backup alarm, seat belt, 600 mm (23.6 in) single grouser shoes, drawbar, counterweight, boom and pulley blocks and cable, and operator.

²Shipping Weight: Includes lubricants, coolant, 10% fuel, hydraulic controls and fluids, backup alarm, seat belt, 600 mm (23.6 in) single grouser shoes, drawbar, counterweight, pulley blocks, and cables.

Lifting Capacities



The machine may tip and personal injury may occur if the maximum load capacities are exceeded. Load capacities assume that the machine is stationary on a level concrete surface with the counterweight extended. Lift capacities will decrease on slopes or soft ground.

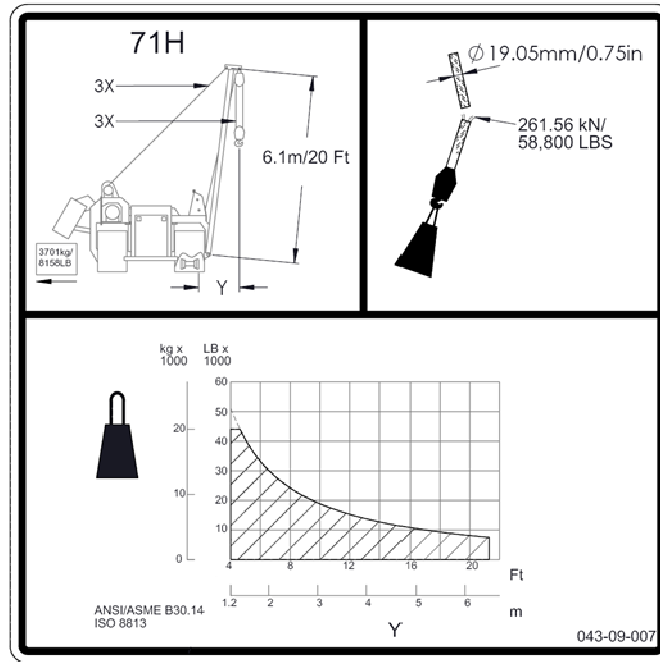

Figure 16: Lifting capacities

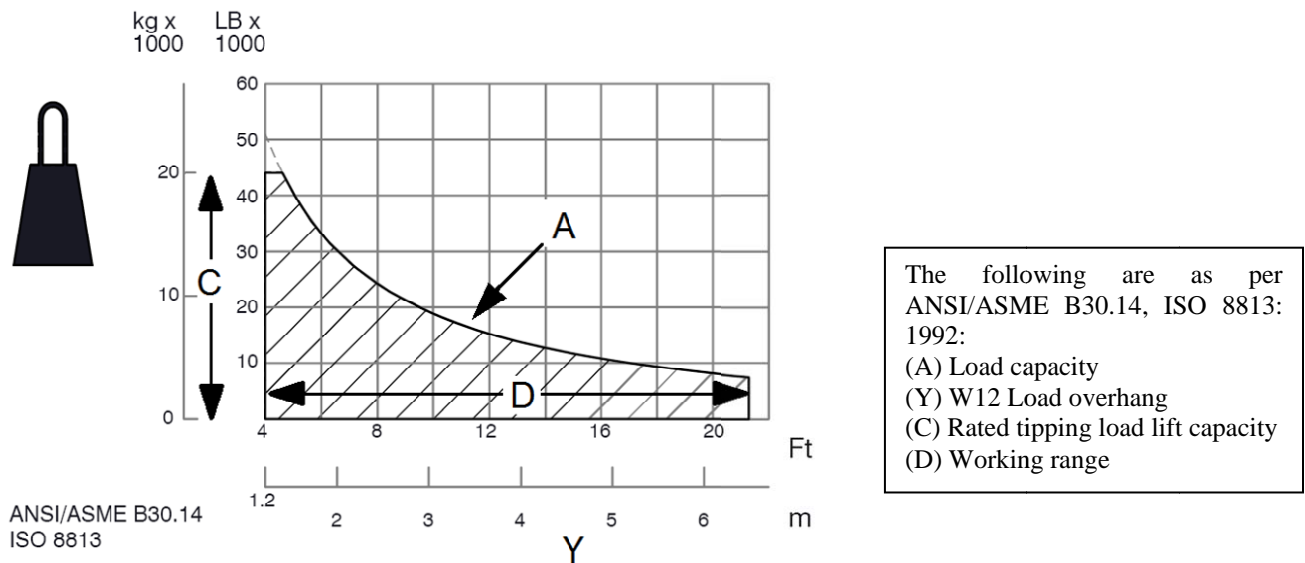

Figure 17: Lift capacity chart

NOTE: Do not exceed the lifting capacity that is shown in the chart in illustration above.

The lift capacity chart is located on the right hand winch-guarding to the front of the controls. The lift capacities are based on a stationary machine with the following specifications:

71H Pipelayer	
Wire rope diameter	19.05 mm (0.75 inch)
Minimum breaking strength of the wire rope	261.56 kN (58,800 lb)
3 part load line	
3 part boom line	
Mass of the extended counterweight	3,701 kg (8,158 lb)
Standard boom length	6.1 m (20 ft)
Total operating weight of the machine³	21 727 kg (47,900 lb)

Table 3: Stationary specifications

If the lift capacity chart indicates that the lift operation is within the capability of the machine, attempt to perform the operation but proceed with care. Remember that the load may weigh more than the estimate for the load. The lift capacity chart is for estimating the lift operation only.

NOTICE

Installation of additional equipment or other options may reduce the tipping characteristics of the machine below those indicated in the chart. Use additional care when working with installed attachments.

Operation Section

Before Operation

Mounting and Dismounting



Figure 18: Mounting and dismounting machine

Use steps and handholds whenever you mount the machine. Use steps and handholds whenever you dismount the machine. Before you mount the machine, clean the step and the handholds. Inspect the step and handholds. Make all necessary repairs.

Face the machine whenever you mount the machine and whenever you dismount the machine. Maintain a three-point contact with the step and with handholds.

Note: Three-point contact can be two feet and one hand. Three-point contact can also be one foot and two hands.

Do not mount a moving machine. Do not dismount a moving machine. Never jump off the machine. Do not try to mount the machine when you carry tools or supplies. Do not try to dismount the machine when you are carrying tools or supplies. Use a hand line to pull equipment onto the platform. Do not use any controls as handholds when you enter the operator compartment or when you exit the operator compartment.

³Operating Weight: Includes lubricants, coolant, 100% fuel, hydraulic controls and fluids, backup alarm, seat belt, 600 mm (23.6 in) single grouser shoes, drawbar, counterweight, boom and pulley blocks and cable, and operator.

Daily Inspection

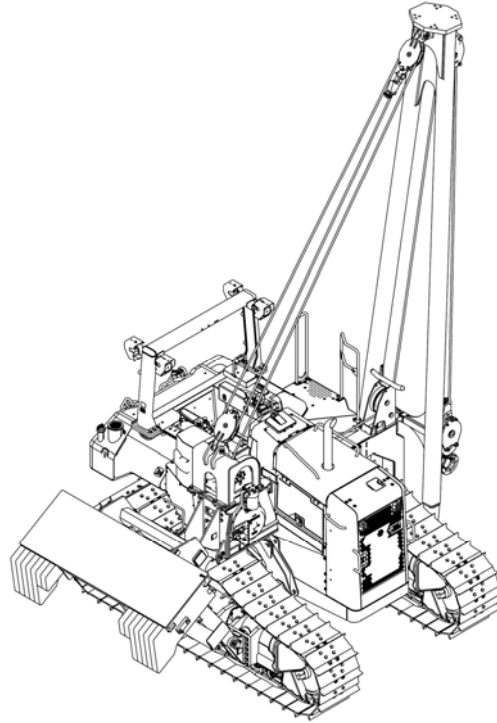

Figure 19: Daily inspection walk around

For maximum service life of the machine, perform a daily walk-around inspection.

Note: Watch closely for leaks. If leaking is observed, find the source of the leak and correct the leak. If leaking is suspected or leaking is observed, check the fluid levels more frequently.

Inspect the machine for the following items:

- Inspect the hydraulic system for leaks. Repair any hydraulic system leaks. Inspect the hoses, the seals, and the flanges.
- Inspect the winch final drive for leaks. Repair any final drive leaks.
- Inspect covers and the guards for damage, for loose bolts, and for missing bolts.
- Inspect the condition of the steps and of the handholds. Inspect the steps and the handholds for cleanliness. If necessary, repair the steps or clean the steps.
- Inspect the operator compartment for cleanliness. Remove any trash buildup and any dirt buildup.
- Inspect mirrors and make sure they are in good condition and replace if broken.

Note: Refer to the tractor operation manual for detailed information on the specific daily inspection of the tractor unit.

NOTICE

Accumulated grease and oil on a machine is a fire hazard.

Remove debris with steam cleaning or high pressure water, at the specified interval in the Maintenance Interval Schedule or each time any significant quantity of oil is spilled on the machine.

Daily Checks

After you inspect the machine, perform the daily maintenance that is listed in the maintenance interval schedule. Perform the daily maintenance before you mount the machine in order to operate the machine.

Refer to Operation and Maintenance Manual, "Maintenance Interval Schedule" for the correct procedures for the following checks:

- "Boom Pivot Pins - Lubricate"
- "Cooling System Coolant Level - Check"
- "Counterweight Cylinder Bearings - Lubricate"
- "Counterweight Hinge Pins - Lubricate"
- "Fairlead Sheave - Lubricate"
- "Hook and Wire Cable Inspect"
- "Hydraulic System Oil Level - Check"
- "Sheave Block Bearings - Lubricate"
- "Boom Stop Valve - Check operation"

Note: Refer to the tractor operation manual for detailed information on the specific daily checks of the tractor unit.

Tractor Operation

Refer to the tractor operation and maintenance manual for the specific procedures regarding complete Tractor Operation.

Hydraulic Oil Temperature

Refer to the tractor operation and maintenance manual "Gauges" for the specific procedures regarding hydraulic oil temperature indication and operating temperature.

Pipelayer Operation

Speed/Lockout Control Lever(1)

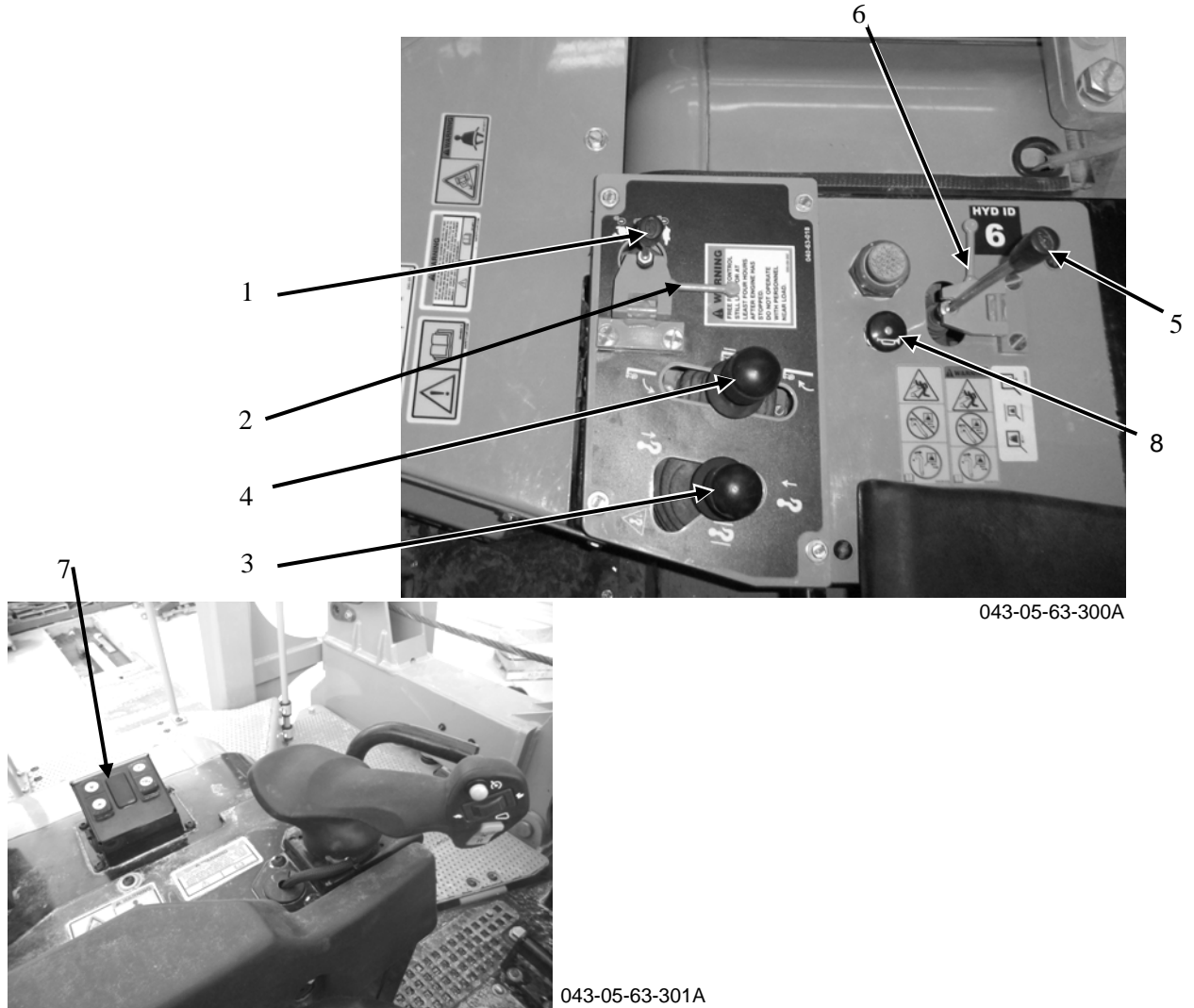

Figure 20: Controls for pipelayer

The speed/lockout control lever has three positions that controls the speed range of the hook winch and prevents accidental actuation of the pipelayer-controls while not in use.



HIGH SPEED MODE—WINCH CONTROLS UNLOCKED: Push the speed/lockout control lever forward for the hook winch at high speed range, the maximum hook winch pull is reduced; the boom winch speed is unaffected.



LOCKED MODE—WINCH AND CONTROLS LOCKED: To prevent accidental actuation of the hook and boom winch controls while not in use, move the speed/lockout control lever to the centre position and flip the speed/lockout control lock to engage the lever (2) and lock it in position. In this mode, the hook and boom winch controls do not function. **Always** place the speed/lockout control lever in the LOCKED MODE **and** engage the speed/lockout control lock whenever the machine is left unattended, or when inadvertent control operation could result in a dangerous situation arising.



LOW SPEED MODE—WINCH CONTROLS UNLOCKED: Pull the speed/lockout control lever back for the hook winch low speed range, maximum hook winch pull is available; the boom winch speed unaffected.

Speed/Lockout Control Lock (2)

Use the speed/lockout control lock lever (2) to lock the speed/lockout control lever (1) in the LOCKED MODE position.

Move the boom control lever to HOLD position. Move the hook control lever to HOLD position. Move the speed/lockout control lever to the centre position. Flip the speed/lockout control lever over the control lever in order to lock the lever in the LOCKED MODE position. This locks the boom controls and the hook controls in HOLD in order to prevent accidental boom movement or hook movement.

Flip speed/lockout control lock away from the speed/lockout control lever in order to allow actuation of the speed/lockout control lever. Move the speed/lockout control lever to the desired speed range in order to operate the winches.

Always move the speed/lockout control lever to the "LOCKED" position before shutting off the engine or immediately after the engine quits running to prevent unintentional load release or--after the engine is restarted-- unintentional drawworks operation.

Hook Control (3)



HOLD: The lever self centres to this position whenever it is released. In this position, the load winch brake will set, and the hook will stop and remain at the position it is in.



Component failure! Re-engaging the free fall while the load is dropping causes shock loads which could cause component structural failure, resulting in possible personnel injury or death.



(Emergency Lower) Free Fall- Move the hook control lever to this position to lower the load fast in an emergency. The load winch's free fall brake will release, and the hook will move down under the weight of the load. Upon activating the free fall function the load will drop and must be allowed to fall to its end travel without re-engagement. The lever will return to the "HOLD" position when released, the load winch's free fall brake will set.

NOTICE

The Free Fall is used for a full release of a suspended load up to the maximum lift capacity of the hook winch. Upon activating the free fall function the load will drop and must be allowed to fall to its end travel without re-engagement.

NOTE: Free Fall is only available in pipelayer HIGH or LOW SPEED mode—Winch Controls Unlocked.



LOWER: Move the lever to this position to lower the hook with controlled winch power. The further the lever is pushed away from HOLD, the faster the hook will lower. The closer the lever is toward HOLD, the slower the hook will lower. When the lever is released, it will return to the HOLD position, the winch brake will set, and the hook will stop and remain at the position it is in. Hook winch line speed varies with engine throttle setting. Hook control is smoothest at engine speeds faster than idle.





RAISE: Move the lever to this position to raise the hook. The further the lever is pulled away from "HOLD", the faster the hook will raise. The closer the lever is toward "HOLD", the slower the hook will raise. When the lever is released, it will return to the "HOLD" position and the hook will stop and remain at the position it is in. Hook winch line speed varies with engine throttle setting. Hook control is smoothest at engine speeds faster than idle.

NOTE: The hydraulic pilot system and some machine controls, namely the hook Free Fall, are "LIVE" for as long as the accumulator holds a charge, even if the engine is not running. This pressure charge will take approximately four hours or more to bleed off. Refer to the operation and maintenance manual "Free Fall Active" for dropping load hazard warning. Refer to the operation and maintenance manual "Accumulator - Relieving Charge" to bleed off the residual pressure if required and when safe to do so.

Accumulator - Relieving Charge

To relieve the accumulator charge, with no load on the hook and the engine stopped, move the *hook control* lever from "HOLD" to "RAISE" 10 times.

Boom Control (4)

- A)  **HOLD:** The lever self centres to this position whenever it is released. In this position, the boom winch brake will set, and the boom will stop and remain at the position it is in.
- B)  **LOWER:** Move the lever to this position to lower the boom. The further the lever is pushed away from HOLD, the faster the boom will lower. The closer the lever is toward HOLD, the slower the boom will lower. When the lever is released, it will return to the HOLD position, and the boom will stop and remain at the position it is in. Boom winch line speed varies with engine throttle setting. Boom control is smoothest at engine speeds faster than idle.
- C)  **RAISE:** Move the lever to this position to raise the boom. The further the lever is pulled away from HOLD, the faster the boom will raise. The closer the lever is toward HOLD, the slower the boom will raise. When the lever is released, it will return to the HOLD position, and the boom will stop and remain at the position it is in. Boom winch line speed varies with engine throttle setting. Boom control is smoothest at engine speeds faster than idle.

Boom Stop Valve

The Boom Stop valve is a safety device that is intended to automatically stop the boom winch from hauling-in when the boom is vertical, preventing overloading of key machine components. Refer to the Operation and Maintenance manual, Boom Stop Valve Adjustment, for correct operation and adjustment. Check its function daily.

Counterweight Control (5)

NOTICE

In order to prevent machine damage, check to make sure the counterweight lock lever is not locked in the extended position before you operate this control lever. Refer to Operation and Maintenance manual, "Safety Section".



Hold - When the operator releases the counterweight control from any position, the control will return to the HOLD and the counterweight will remain in position.



Out - Move the counterweight control to this position in order to move the counterweight outward. When the counterweight control is released, the returns to the HOLD position and the counterweight will remain in position.

Refer to the Operation and Maintenance Manual, "Counterweight Lock Lever" for the procedure to mechanically lock the counterweight in the fully extended position when you service the machine.



In - Move the counterweight control lever to this position in order to move the counterweight inward. When you release the counterweight control lever the lever returns to the HOLD position and the counterweight will remain in position.

Counterweight Control-Lockout Lever (6)

Use the counterweight control-lockout lever (6) to lock the counterweight control (5) in the HOLD position in order to avoid accidental actuation of the counterweight. Move the counterweight control (5) to the HOLD position. Flip the counterweight control-lockout lever (6) forward in order to lock the counterweight control (5) in the HOLD position.

Flip the lock lever (6) to the rear position in order to allow actuation of the counterweight control.

Throttle control switch & Operator Heater switch (7)

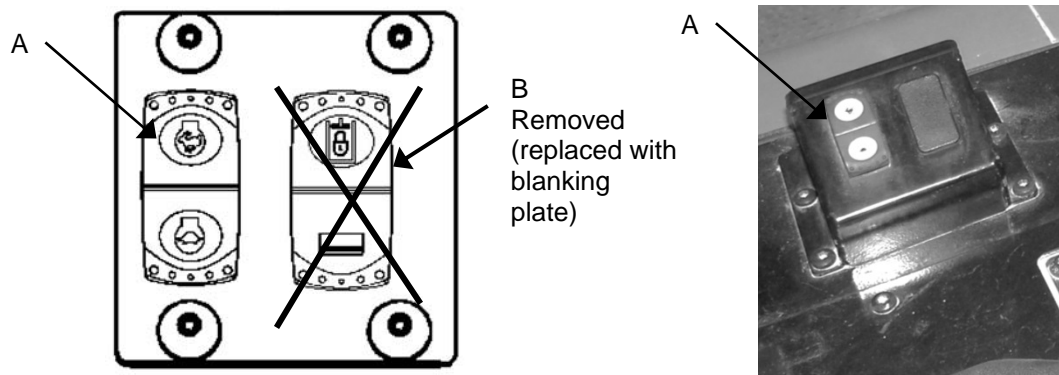

043-05-63-002A

Figure 21: Control Switches

- A. Throttle Control Switch, Refer to tractor's operation and maintenance manual for correct operation
- B. Hydraulic lockout switch—Removed [use Speed/Lockout Control Lock (2) and Counterweight Control-Lockout Lever (6)]

Horn location moved (8)

NOTE: New location of this tractor's control, refer to the tractors operation and maintenance manual for correct operation.

Counterweight Lock Lever



Crushing Hazard! When the counterweight is in the fully extended position for servicing the machine, secure the extended counterweight with the counterweight lock lever. Use the counterweight lock lever to avoid possible personnel injury or death from crushing.

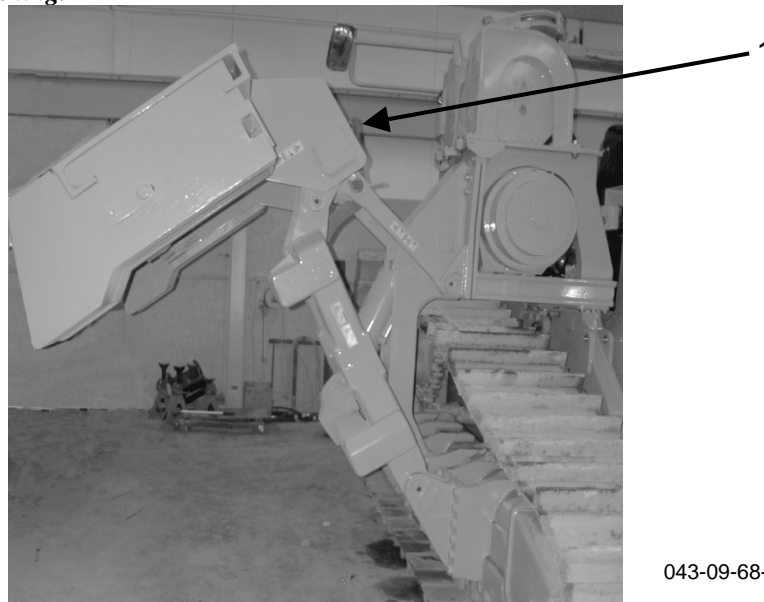

043-09-68-001

Figure 22: Counterweight Lock Lever (1) locked in the extended position, viewed from front

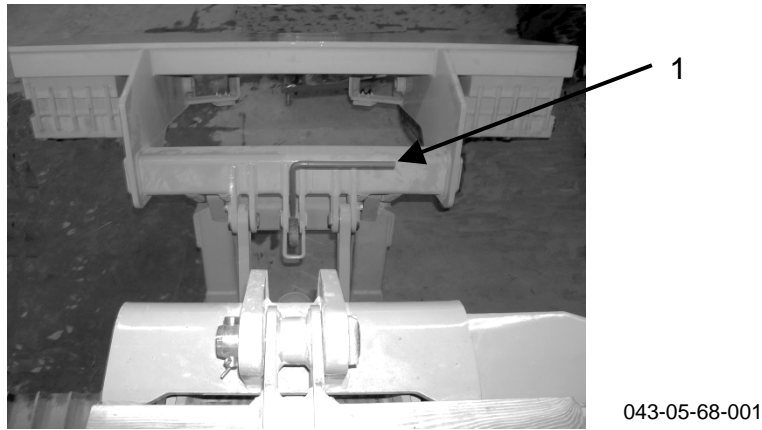

Figure 23: Counterweight Lock Lever (1), locked in the extended position, side view (1)

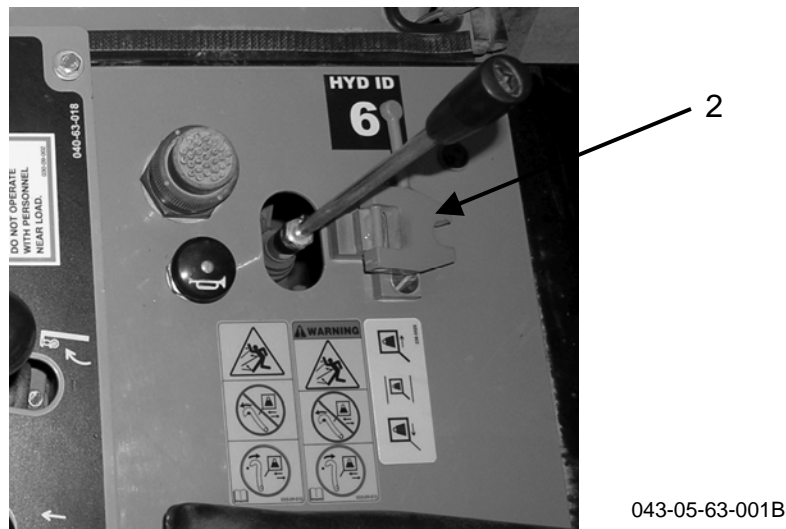

Figure 24: Counterweight control-lockout(2), open position

NOTICE

When you engage the locking device for the counterweight or when you disengage the locking device for the counterweight use the Counterweight Control-Lockout lever for the counterweight controls. Lock the counterweight controls in HOLD in order to avoid the inadvertent movement of the counterweight. Refer to the topic "Counterweight Control-Lockout Lever" in the Operation and Maintenance Manual, "Operator Controls".

Lock the counterweight control-lockout (2) in the operator station when you service the machine.

Lock the counterweight when you service the machine.

Locked - Extend counterweight cylinders to maximum length Engage the lock lever (1).

Slowly retract the counterweight slightly until there is pressure on the lock lever (1). Do not continue to retract the counterweight against the lock lever once the lock lever is engaged. Refer to Operation and Maintenance manual, Safety Section "Counterweight Lock Lever Thrown or Flying Objects – Full Body Exposure".

Unlocked -Unlock the counterweight control-lockout (2) in the operator station. Extend counterweight cylinders to maximum length. Disengage the lock lever (1). Retract the counterweight.

The locking mechanism will hold the counterweight in position in the event of a hydraulic failure.

Equipment Lowering with Engine Stopped

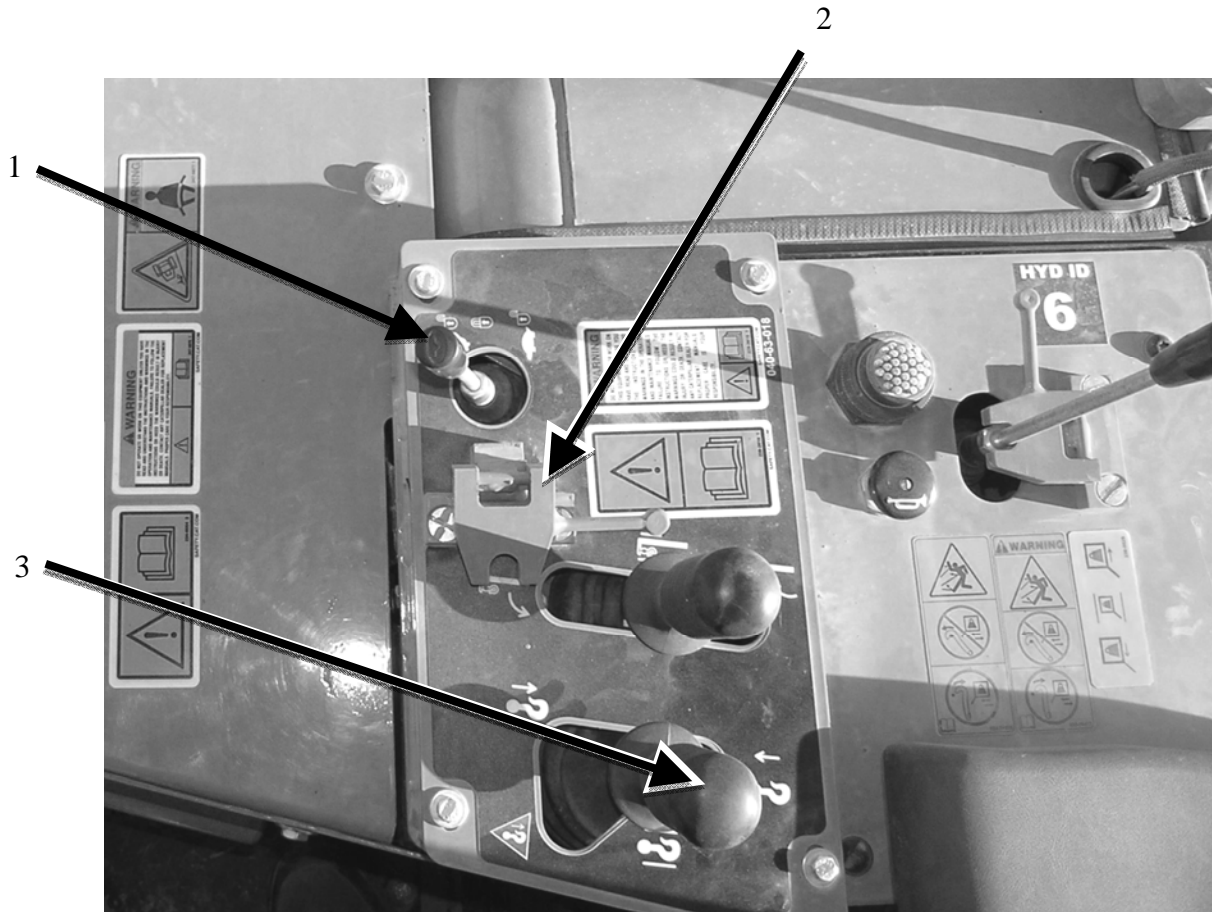

043-05-63-302A

Figure 25: Controls for Equipment lowering with engine stopped

NOTICE

Before lowering any equipment with the engine stopped, clear the area around the equipment of all personnel. The procedure will cause immediate, rapid lowering of the load. Refer to Operation and Maintenance Manual, "Hook Control" for complete control function description.

If the machine does not have engine power, in order to lower the equipment follow these steps:

- Unlock the Speed/Lockout Control Lock (2) and move the Speed/Lockout Control Lever (1) HIGH SPEED MODE—WINCH CONTROLS UNLOCKED



- Move the hook control (3) to  (Emergency Lower) Free Fall.
- If the accumulator still has residual pressure reserve, it will provide pilot pressure that will allow the hook to be immediately lowered fast under the weight of the load.

Note: Pilot pressure bleeds off quickly in LOW SPEED, so switch to HIGH SPEED as soon as possible after an engine shutdown to conserve the pressure reserve in the accumulator.

- Do not release the hook control to re-engage the Free Fall until the load is completely lowered.
- Refer to the Testing and Adjusting manual for pressure charging procedures if there is insufficient pressure reserve in the accumulator.

Machine Warm-Up

NOTICE

Refer to the tractor operation and maintenance manual for additional requirements and information on Engine and Machine Warm-Up.

The hydraulic oil will warm up faster, if the counterweight is fully retracted and the counterweight control lever is held in the IN () position. With the counterweight fully retracted, hold the counterweight control lever in the IN position for short periods of 10 seconds or less. This action will allow the hydraulic oil to reach the counterweight retract relief pressure, which causes the hydraulic oil to warm up more rapidly.

Once the hydraulic oil is sufficiently warm, set the engine idle to LOW. Set the winch mode selector to LOW SPEED MODE--WINCH CONTROLS UNLOCKED ().

Cycle all controls in order to allow warm hydraulic oil to circulate through the hydraulic system and through all hydraulic lines:

Slowly cycle the hook winch up and down several times (5 - 10).

Set the engine idle to HIGH idle (full throttle).

Set the winch mode selector to LOW SPEED MODE--WINCH CONTROLS UNLOCKED ().

Slowly cycle the hook up and down 2 - 3 times.

Rapidly cycle the hook up and down several.

Set the engine idle to LOW.

Slowly raise the boom up, stopping the boom at the 1.25 m (4 ft) overhang.

Slowly cycle the boom fully down and then up, stopping the boom at the 1.25 m (4 ft) overhang. Do not allow the boom to contact the boom kickout rod or the left-hand frame. Repeat this 2 - 3 times.

Set the engine idle to HIGH idle (full throttle).

Slowly cycle the boom fully down and then up, stopping the boom at the 1.25 m (4 ft) overhang. Do not contact the left-hand frame or the boom kickout rod. Repeat this 2 - 3 times.

Rapidly cycle the boom down, and then up stopping the boom at the 1.25 m (4 ft) overhang. Do not contact the left-hand frame or the boom kickout rod.

Verify the function of the Boom Stop Valve as per the "Boom Stop Valve Adjustment" section in this manual.

Transportation Information

Shipping the Machine

Investigate the travel route for overpass clearances. Make sure that there is adequate clearance for the machine that is being transported.

Remove ice, snow, or other slippery material from the loading dock and from the truck bed before loading. Removing ice, snow, or other slippery material will prevent slippage while you load the machine. Removing ice, snow, or other slippery material will prevent the machine from slipping in transit.

NOTICE

Obey all state and local laws governing the weight, width, and length of a load. Observe all regulations governing wide loads.

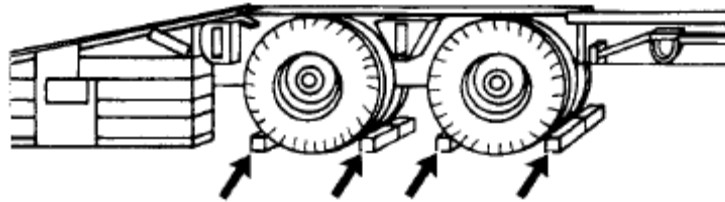

1. Place blocks under the trailer wheels or under the rail car wheels before loading, as shown.
2. Move the transmission control lever to the NEUTRAL position.
3. Engage the parking brake switch.
4. Stop the engine.
5. Turn the start switch key to the OFF position. Remove the key and lock the parking brake switch.
6. Turn the battery disconnect switch to the OFF position. Remove the key.
7. Attach any vandalism protection and lock the access covers.
8. Install the tie-downs at several locations and chock the tracks in the front and in the rear.
9. Cover the opening for the engine exhaust in order to prevent rotation of the turbocharger that is caused by the force of the wind.

NOTICE

Rotation of the turbocharger without engine operation can result in damage to the turbocharger. Cover the exhaust opening or secure the rain cap in order to prevent the turbocharger from wind milling in transit. Refer to the tractor operation and maintenance manual for additional requirements and information.

Lifting and Tying Down the Machine



Improper lifting and improper tie-downs can allow the load to shift or fail and cause injury or damage. Use only properly rated cables and slings with lift and tie down points provided.

Follow the instructions in Operation and Maintenance Manual, “Lifting and Tying Down the Machine” for the proper technique for securing the machine. Refer to Operation and Maintenance Manual, “Specifications” for specific pipelayer weight information.

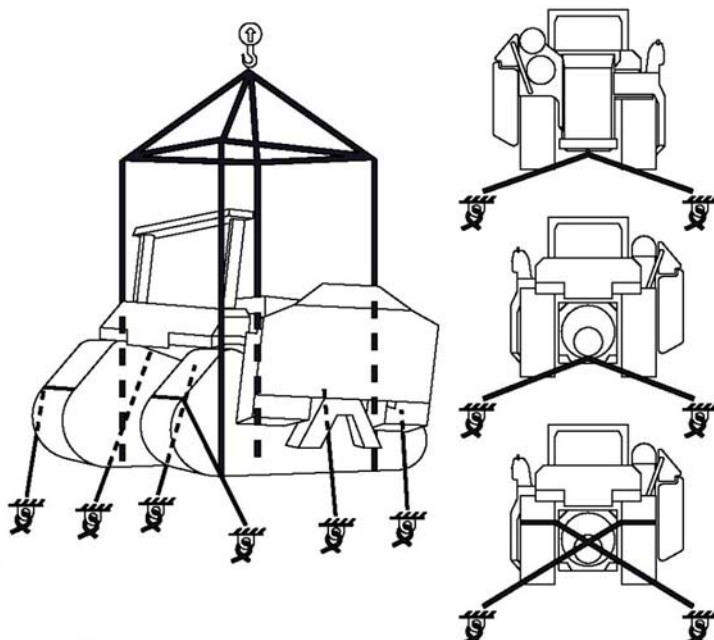

An image of a standard equipped pipelayer is shown for example only.

NOTICE

Improper lifting or tie-downs can allow load to shift and can cause injury and damage.

Refer to the tractor’s *Operation and Maintenance Manual* for correct lifting and tying down procedures, including precautions and for locations of tie-downs.

Towing Information

Refer to the tractor's *Operation and Maintenance Manual* for correct towing procedures.



Personal injury or death could result when towing a disabled machine incorrectly. Block the machine to prevent movement before releasing the brakes. The machine can roll free if it is not blocked. Refer to the tractor's operation and maintenance manual for complete detailed towing instructions.



Personal injury or death can result from worn wire rope cable. Worn or frayed cable could break causing injury. Check the wire rope cable. If cable is worn or is frayed install a new cable.

NOTICE

DO NOT connect to any part of the pipelayer structures or components for towing purposes of any kind.

DO NOT connect to any front mounted attachments for towing purposes of any kind, unless the attachment is specifically intended for towing purposes.

DO NOT connect to any rear mounted attachments for towing purposes of any kind, unless the attachment is specifically intended for towing purposes.

Refer to the tractor's *Operation and Maintenance Manual* for correct towing procedures.

Removal of the Boom

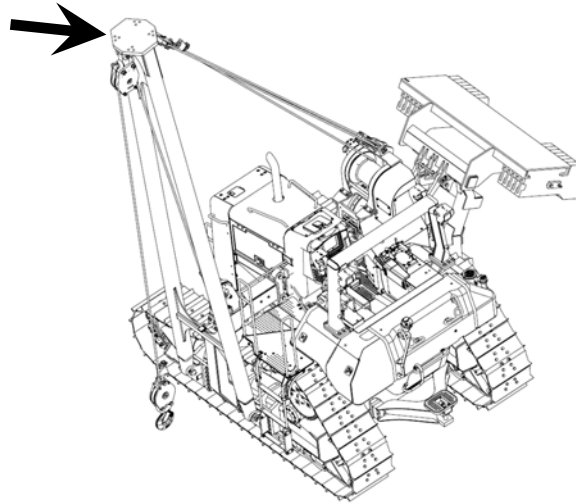

Figure 26: Removal of the boom

1. Lower the boom enough to remove the load blocks and the sheave block.

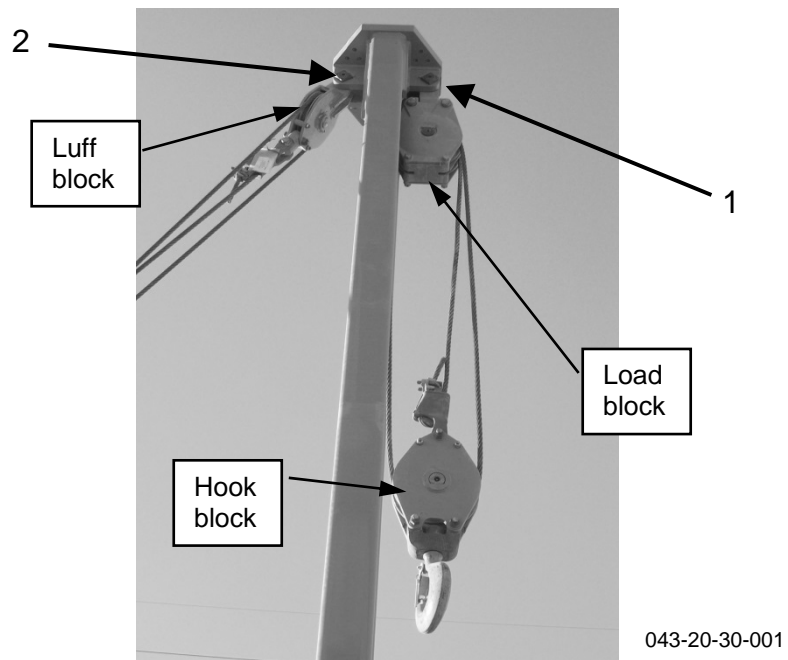

Figure 27: Removal of boom, steps 1, 2

2. Remove cotter pin, the retainer, and pin (1). Lower the load block and the hook block to the ground.

The approximate weight of the load block is 87 kg (192 lb). The approximate weight of the hook block is 73 kg (160 lb). The combined weight of the load block and the hook block is approximately 160 kg (352 lb).

3. Replace the pin (1) in the boom.

- Place the load block and the hook block in the front-mounted rigging tray, and secure the blocks to the tray for transportation.

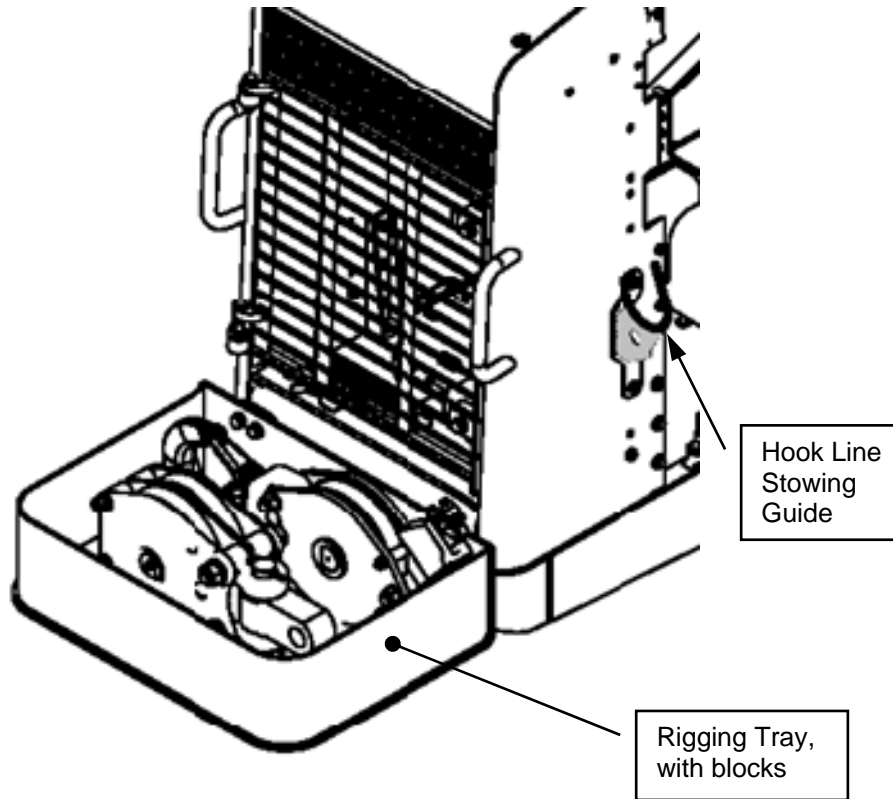

Figure 28: Secure Load and Hook Blocks for Transport

- Draw in the excess hook cable in order to pull the sheave blocks to the machine. Use the Hook Line Stowing Guide to keep the line clear of the tracks. DO NOT over tighten the cables.
- Lower the boom to the horizontal position onto wood blocks that are sufficient to support the boom.
- Remove the cotter pin, the retainer, and pin (2). The approximate weight of the luff block is 39 kg (85 lb).
- Replace the pin and the retainer (2) in the boom.
- Move the luff block clear of the boom and area; it will be secured after the boom has been removed.

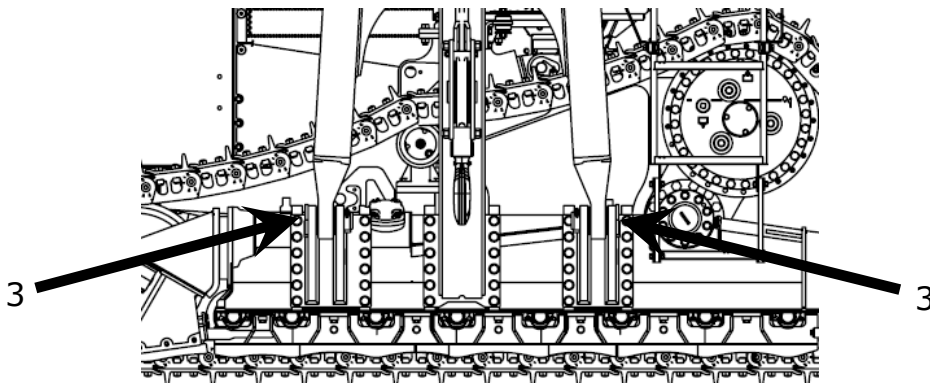

Figure 29: Location of pins for removal of boom

- Fasten an appropriate lifting device to the boom. The approximate weight of the boom is 965 kg (2127 lb).

11. Remove the cotter pins, the retainers, and the pins (3) from both sides of the support.
12. Remove the boom from the machine. Replace the pins (3) in the support.
13. Draw in the excess line for the boom in order to pull the luff block to the machine, ensuring not to over tighten the cables to avoid causing kinks.

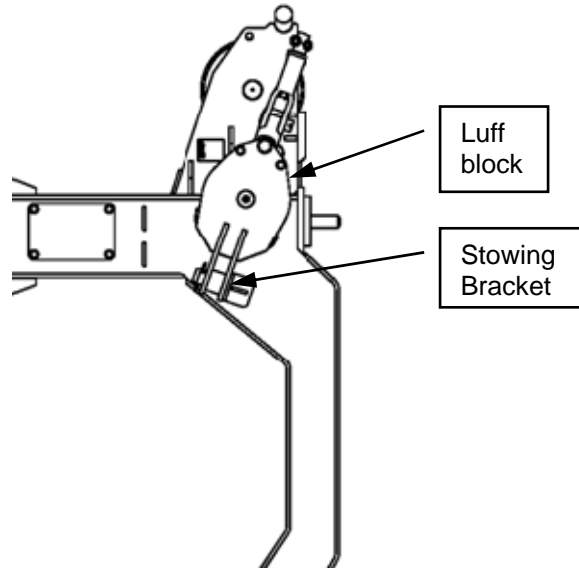

Figure 30: Secure Luff Block for Transport

14. Secure the Luff Block to the stowing bracket on the left hand frame, and retain with a Ø3/8" x 4" long cotter pin all blocks to the machine when transporting.

NOTICE

DO NOT over tighten lines. DO NOT kink or flatten lines.

Maintenance and Lubrication Section

Lubricant Viscosities - General

- Follow tractor manufacture's maintenance and lubrication instructions for tractor service as required.
- Follow tractor and/or winch manufacture's lubrication instructions for the pipelayer hydraulic system.

Selecting the Viscosity

The proper oil viscosity grade is determined by the minimum outside temperature. This is the temperature when the machine is started and when the machine is operated. In order to determine the proper oil viscosity grade, refer to the "Min" column in the table. This information reflects the coldest ambient temperature condition for starting a cold machine and for operating a cold machine. Refer to the "Max" column in the table in order to select the oil viscosity grade for operating the machine at the highest temperature that is anticipated. Use the highest oil viscosity that is allowed for the ambient temperature when you start the machine.

Machines that are operated continuously should use oils that have the higher oil viscosity in the final drives and in the differentials. The oils that have the higher oil viscosity will maintain the highest possible oil film thickness. Consult your dealer if additional information is needed.

Lubricant Viscosities for Ambient Temperatures

Lubricant Viscosities for Ambient Temperatures						
Compartment or System	Oil Type and Classification	Oil Viscosities	°C		°F	
			Min	Max	Min	Max
Hydraulic System	Refer to Tractor Operation and Maintenance Manual					
Winch Gearbox and Hook Winch Freefall	Mobil Delvac Synthetic Gear Oil	75W-90	-40	50	-40	122
	CAT Arctic GO	75W-90	-40	40	-40	104
Winch Brake	Cat HYDO Advanced 10	SAE 10W	-20	40	-4	104
	Cat HYDO Advanced 30	SAE 30	0	50	32	122
	Cat BIO HYDO Advanced	“ISO 46” Multi-Grade	-30	45	-22	113
	Cat DEO-ULS Cold Weather	SAE 0W-40	-40	40	-40	104
	Cat TDTO Cold Weather	SAE 0W-20	-40	40	-40	104
	Cat MTO	SAE10W-30	-20	40	-4	104
	Cat TDTO-TMS	Multi-Grade	-15	50	5	122

Table 4: Lubricant viscosities for ambient temperature

Lubricant Capacities (Refill)

NOTICE

Use only none EP-Oil in the winch brake housing. Do not use Gear Oil in the brake housing.

NOTICE

Do not use Cat GO (Gear Oil) or commercial gear oil in the machine compartments unless specifically recommended by Caterpillar. The gear oil can cause seals to fail. The seals can also leak. The gear oil may not be compatible with friction materials. The oil can reduce the efficiency of the transmission and the brake performance. Refer to the Tractor Operation and Maintenance Manual for complete details.

APPROXIMATE LUBRICANT REFILL CAPACITIES			
Compartment or System	Liters	US gal	Imperial gallon
Hydraulic Oil (Tank only)	29.5	7.79	6.48
Hydraulic Oil (System)	41.5	11	9.13
Hook Winch Freefall	4	1.05 (4.2 Quarts)	0.87
Hook Winch Brake	0.24	0.06 (0.25 Quart)	0.05
Hook Winch Gearbox	1.9	0.5 (2 Quarts)	0.42
Boom Winch Brake	0.24	0.06 (0.25 Quart)	0.05
Boom Winch Gearbox	0.95	0.25 (1 Quart)	0.21

Table 5: Lubricant refill capacities

S-O-S Information

S O S Services is a highly recommended process for Caterpillar customers to use in order to minimize owning and operating cost. Customers provide oil samples, coolant samples, and other machine information. The dealer uses the data in order to provide the customer with recommendations for management of the equipment. In addition, S O S Services can help determine the cause of an existing product problem. Refer to Caterpillar Special Publication, SEBU6250, "Caterpillar Machine Fluid Recommendations" for detailed information concerning S O S Services.

Refer to the Operation and Maintenance Manual, "Maintenance Interval Schedule" for a specific sampling location and a service hour maintenance interval.

Consult your dealer for complete information and assistance in establishing an S-O-S program for your equipment.

Maintenance Interval Schedule (MIS)

Ensure that all safety information, warnings, and instructions are read and understood before any operation or any maintenance procedures are performed. The user is responsible for the performance of maintenance, including all adjustments, the use of proper lubricants, fluids, filters, and the replacement of components due to normal wear and aging. Failure to adhere to proper maintenance intervals and procedures may result in diminished performance of the product and/or accelerated wear of components. Use mileage, fuel consumption, service hours, or calendar time, WHICH EVER OCCURS FIRST, in order to determine the maintenance intervals. Products that operate in severe operating conditions may require more frequent maintenance.

Service Intervals

Note: Before each consecutive interval is performed, all maintenance from the previous interval must be performed. Perform the following servicing at EVERY interval they occur; for example, the 10 hour and 50 hour service are also performed at the 200 hour interval, etc.

When Required

- Boom Line – Install
- Hook Load Line – Install

Every 10 Service Hours or Daily

- Controls for proper operation of boom and hook – Check
- Boom Stop operation – Check, adjust if required
- Boom Pivot Pins – Lubricate
- Counterweight Cylinder Bearings – Lubricate
- Counterweight Hinge Pins – Lubricate
- Fairlead Sheave – Lubricate
- Hook and Wire Cable (Boom and Hook lines) – Inspect
- Hydraulic System Oil Level – Check
- Hoses and fittings for leaks – Check
- Sheave Block Bearings – Lubricate
- Pipelayer structures and components for loose bolts, cracks, damage, etc. – Inspect
- Inspect the hook for any distortion, bends, twists, etc. Inspect the hook for any wear, cracks, nicks, or gouges. Refer to American National Standard Institute ANSI/ASME B30.14, or ISO 8813.
- Blocks, and yokes for wear or damage – Inspect
- Ensure that area between tractor tracks and pipelayer-structures are free from dirt, debris, ice, snow, etc. – Inspect
- Hook Winch check – refer to Winch OEM Service Manual in the appendices of this manual
- Boom Winch check – refer to Winch OEM Service Manual in the appendices of this manual

Every 50 Service Hours or Weekly

- Thoroughly check Boom Stop system operation and adjustment, lubricate boom stop valve roller and actuator.
- Lightly lubricate wire rope with recommended engine or hydraulic oil.
- Hook Winch: Freefall, Brake, Gearbox oil level – Check
- Boom Winch: Brake, Gearbox oil level – Check
- Hook Winch check – refer to Winch OEM Service Manual in the appendices of this manual
- Boom Winch check – refer to Winch OEM Service Manual in the appendices of this manual

Every 500 Service Hours

- Hydraulic System Oil Sample - Obtain

Every 500 Service Hours or 3 Months

- Hydraulic System Oil Filter – Replace
- Hydraulic System Case Drain Filter - Replace

Every 1000 Service Hours or 6 Months

- Hook Winch: Freefall, Brake, Gearbox Oil– Change
- Boom Winch: Brake, Gearbox Oil– Change

Every 2000 Service Hours or 1 Year

- Hydraulic System Oil - Change

Accumulator



This system contains high pressure gas. Failure to follow the instructions and warnings could cause an explosion, resulting in possible injury or death. Do not expose to fire. Do not weld. Do not drill. Do not remove any hydraulic system lines, taps or parts until pressure has been relieved. Relieve pressure before discharging. See Operation and Maintenance Manual "Accumulator - Relieving Charge". See Operation and Maintenance Manual "Accumulator" for charging and discharging. See your Dealer for tools and detailed information.

Accumulator must be charged with dry nitrogen (N₂) gas by qualified personnel only. Gas pressure varies the temperature. The accumulator must be at the same temperature as the surrounding air before being checked or charged. Charge the accumulator according to the precharge table below, see the figure below. NOTE: The precharge value on the accumulator label is for an ambient temperature of 20°C (68°F).

Instructions continued on next page.

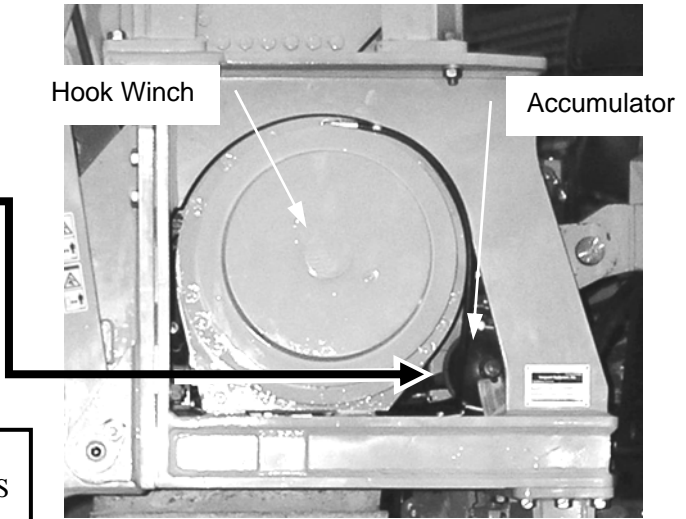
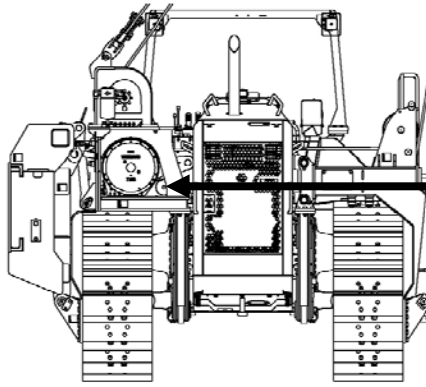

043-05-60-001A

ACCUMULATOR PRECHARGE PRESSURE VARIES WITH SURROUNDING AIR TEMPERATURE

Temperature	Precharge Pressure
-30°C (-22°F)	4517 kPa (655 psi)
-25°C (-13°F)	4610 kPa (670 psi)
-20°C (-4°F)	4705 kPa (680 psi)
-15°C (5°F)	4795kPa (695 psi)
-10°C (14°F)	4890kPa (710 psi)
-5°C (14°F)	4980kPa (720 psi)
0°C (32°F)	5075kPa (735 psi)
5°C (41°F)	5170kPa (750 psi)
10°C (50°F)	5260kPa (765 psi)
15°C (59°F)	5355kPa (775 psi)
20°C (68°F)	5445kPa (790 psi)
25°C (77°F)	5540kPa (805 psi)
30°C (86°F)	5630kPa (815 psi)
35°C (95°F)	5725kPa (830 psi)
40°C (104°F)	5820kPa (845 psi)
45°C (113°F)	5910kPa (857 psi)
50°C (122°F)	6005kPa (870 psi)

Accumulator must be charged with dry nitrogen (N₂) gas by qualified personnel only.

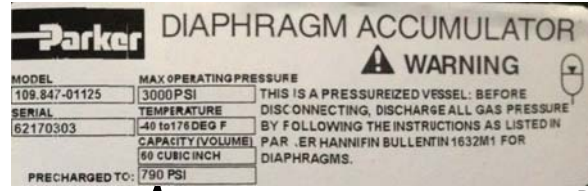

043-09-60-300B

PRECHARGE on label is for 20°C

Figure 31: The hydraulic accumulator is located on the right side of the operator seat, on the winch base to the left of the hook winch.

Boom Stop Valve Operation and Adjustment

⚠ WARNING

The Boom Stop system stops the boom winch from hauling-in when the boom is vertical, preventing overloading of key machine components. Incorrectly adjusting, or defeating the boom stop valve could result in serious equipment damage, personal injury, or even death. Its operation must be checked and verified daily.

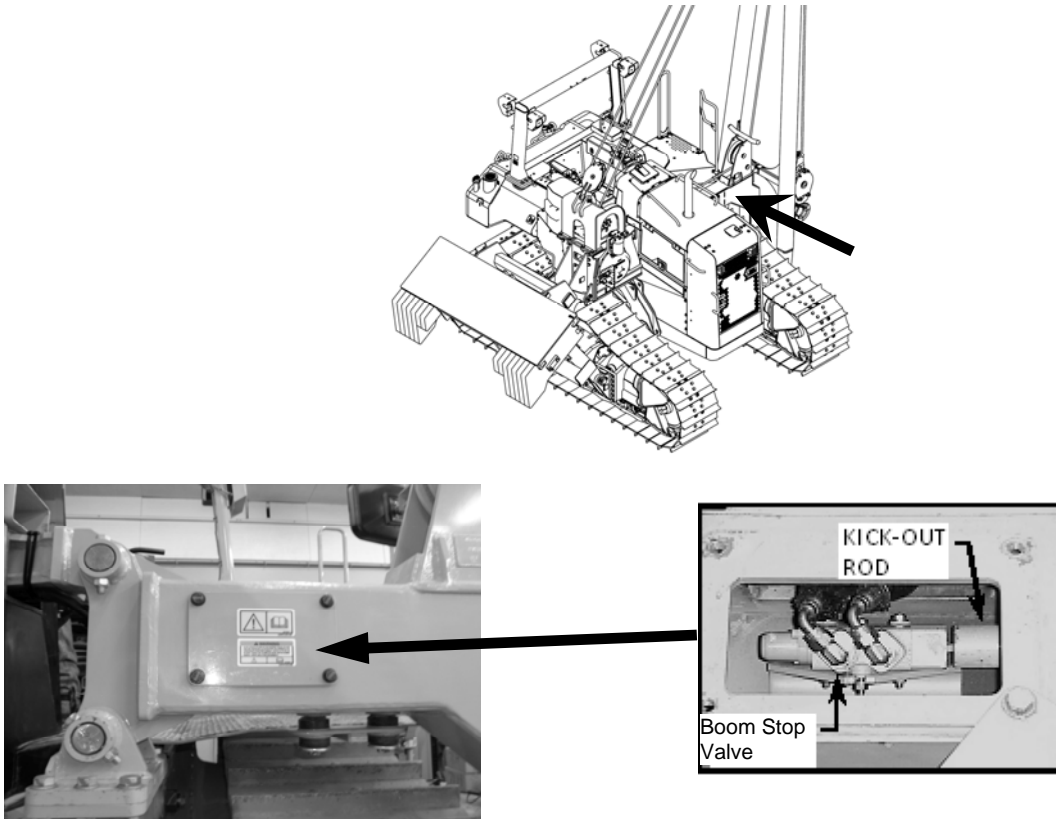

043-09-12-001

Figure 32: Boom stop valve located behind access cover in Left Hand tower.

- To check the operation, boom in slowly taking care not to over tension the boom lines when the boom goes vertical. When the boom is vertical, the boom winch should stop. No increase in tension should occur once the boom comes into contact with the left hand tower. If the boom winch does not stop and continues to increase the cable tension, STOP the operation at once and lower the boom to release the tension. Adjust the boom stop valve as set out below.
- Raise the boom vertical so that it is **JUST** in contact with the tower; the boom kick-out rod is fully retracted into the tower. Do not over tighten the lines to the point that the boom or structures are overly stressed.
- Remove the boom stop valve access panel from the tower.
- Loosen the boom stop valve nuts.
- Move the valve so that it just contacts the boom kick-out rod.
- Move the valve an additional 10 mm (3/8-in) towards the boom so that the valve's piston is fully depressed.
- Tighten the valve in position with the valve nuts.
- Test the boom stop valve to see that it works properly. Lower the boom until the boom stop valve piston is free from the kick-out rod.
- Replace the boom stop valve access panel from the tower.
- Boom in slowly taking care not to over tension the boom lines when the boom goes vertical. When the boom is vertical, the kick-out rod will move the boom stop valve piston in 9.5 mm (3/8 in), and the boom winch should stop with the boom vertical. No increase in tension should occur once the boom comes into contact with the left hand tower, readjust the boom stop valve as required.

Boom Line – Install



Do not operate or work on this equipment unless you have read and understand the instructions and warnings in the Operation and Maintenance Manual. Failure to follow the instructions or heed the warnings could result in injury or death. Contact your dealer or Vanguard Equipment or visit our website at vanguardequip.com for replacement manuals. Proper care is your responsibility.



Personal injury or death can result from worn wire rope cable. Worn or frayed cable could break causing injury. Check the wire rope cable. If cable is worn or is frayed install new cable. Wear gloves when handling the wire rope cable. Proper care is your responsibility.

NOTICE

Make sure that the construction of the wire rope is 6x25 IWRC XIPS (Independent Wire Rope Core, eXtra Improved Plow Steel) conforming to ISO 2408. Also, the established grade of the wire rope is the improved plow bolt (steel), 26670 kg (58,800lb) minimum breaking strength.

SPECIFICATIONS (WIRE ROPE)		
Boom Line Cable		
Boom Length	Diameter of Cable	Length of Cable
6.1m (20 ft)	19.05 mm (0.75 inch)	41.1 m (135 ft)

Table 6: Boom line wire rope specifications

1. Lower the boom to the ground and support the boom.

Note: The loaded force in the winch drum must be neutralized before removing the wire rope from a loaded drum.

2. Remove the anchor for the wire rope from the drum for the boom. Remove the old wire rope.
3. Unroll the new wire rope from the spool.

Note: Weld the cable ends in order to prevent fraying.

NOTICE

Unroll all of the cable from the spool. Lay the wire rope on a flat surface. Never lift the wire rope off the spool in coils.

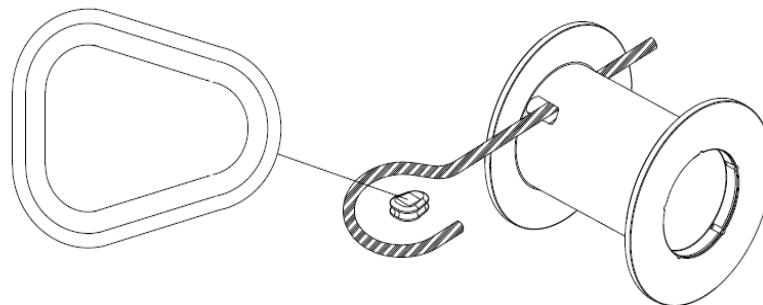
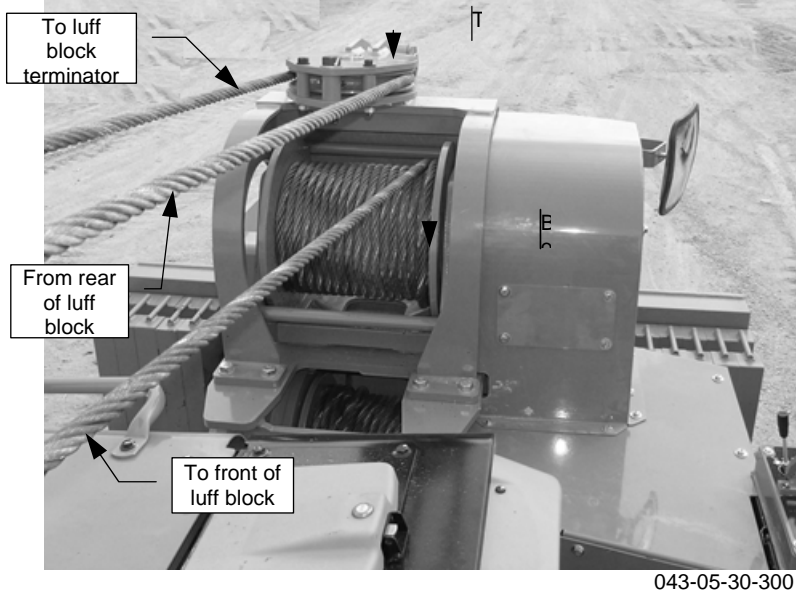

Figure 33: Installing boom line, cable anchor assembly

4. Install the cable into the small slot and through the larger slot in the drum for the boom.
 - a. Start with inserting the cable anchor into the longer slot as far as allowed.

- b. Make a loop with the end of the wire rope and insert the end into the slot past the cable anchor.
- c. Pull the wire rope until the wire rope and anchor assembly are securely seated inside the slot.

5. Wind one half of the wire rope on the drum. Wind the wire rope evenly across the drum.



043-05-30-300

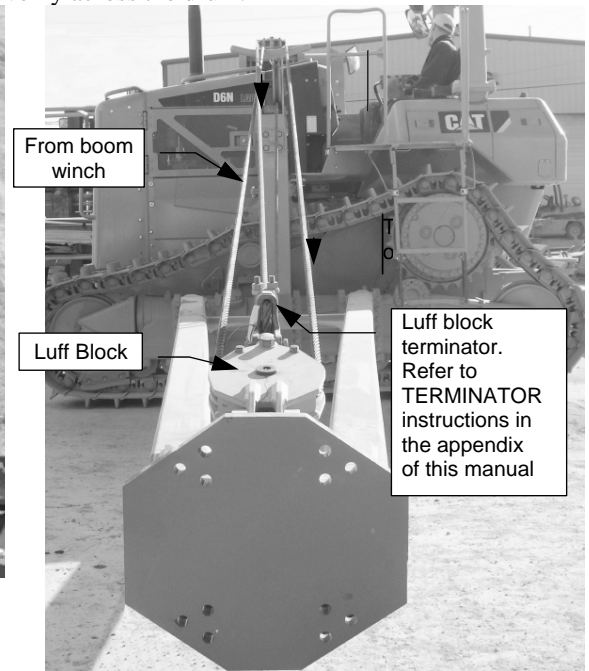

043-05-30-001

Figure 34: Installing boom line

- 6. Install the wire rope from the boom winch to front of the luff block. Install the wire rope from the front of the machine toward the rear of the machine.
- 7. Secure the line to the line terminator on the Luff block, as per Terminator instructions outlined in the **Appendix**.

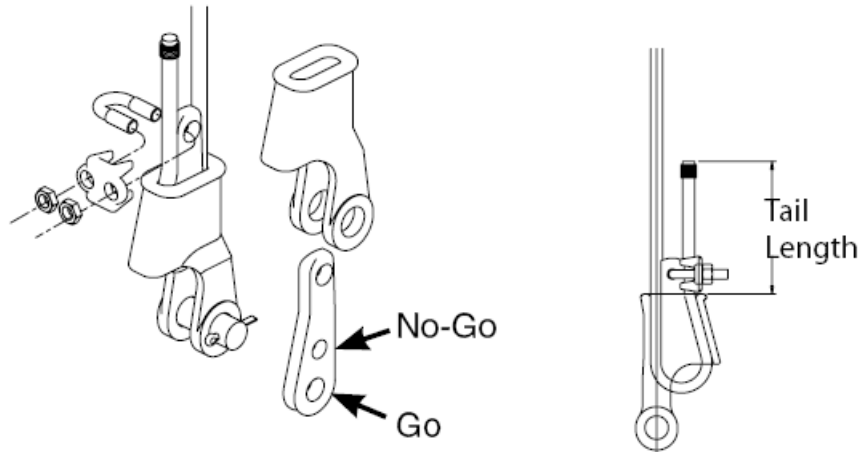

NOTE: Do not clamp the loaded end of the wire rope and the tail end of the wire rope together. Refer to TERMINATOR instructions in the appendix of this manual.

- 8. Apply a test first load in order to seat wedge.

Boom Pivot Pins – Lubricate

The grease fittings for lubricating the boom pivot pins are located on the left side of the machine.

There is one grease fitting for each pin. The grease fittings are located on the end of the pin on the outside face of the boom.

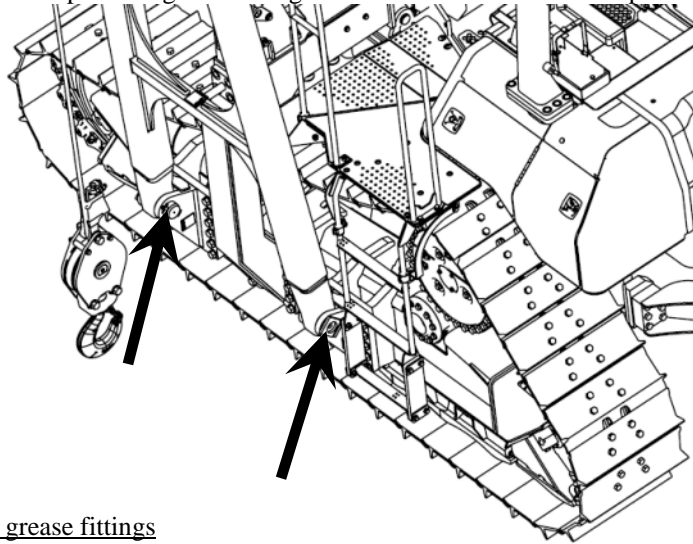

Figure 35: Boom pivot pins, grease fittings

Lubricate the boom pivot pins through the two fittings.

Counterweight Cylinder Bearings – Lubricate

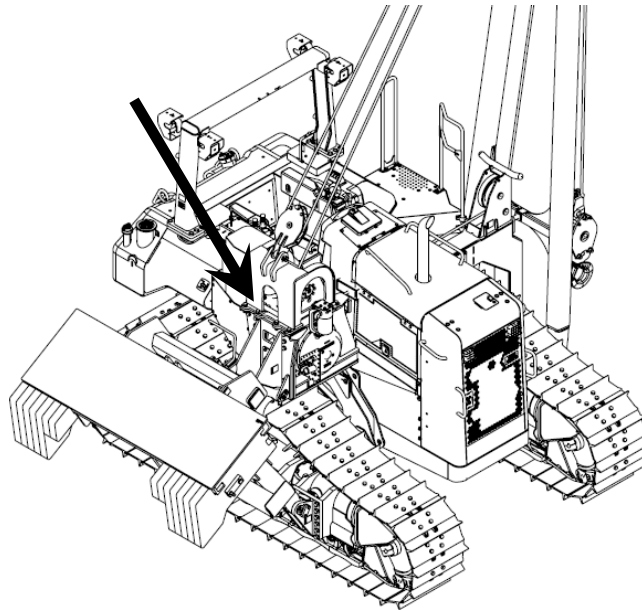
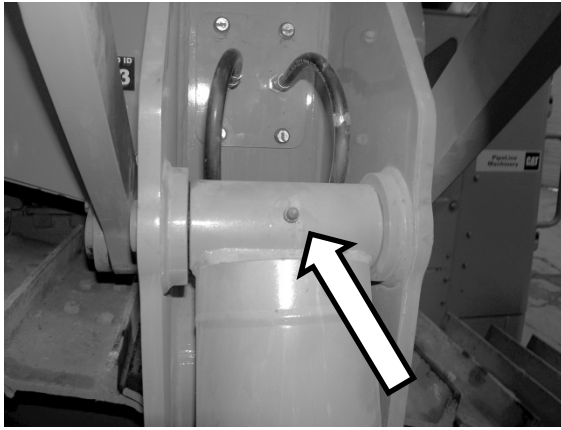
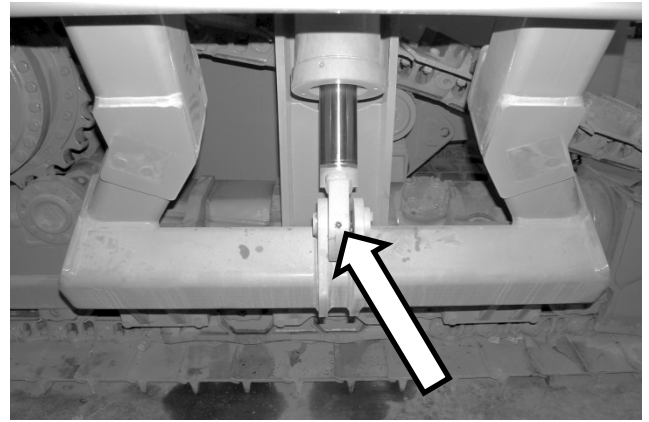

Figure 36: Counterweight cylinder bearings fittings location



043-60-68-001



043-60-68-002

Figure 37: Counterweight cylinder bearings location

There are two grease fittings for the counterweight cylinder.

1. Extend the counterweight and lock the counterweight into position.

Refer to the Operation and Maintenance Manual, “Counterweight Lock Lever” for the proper procedure to lock the counterweight into position.

2. Lubricate the upper grease fitting that is located in the head end of the cylinder.
3. Lubricate the grease fitting that is located in the rod end of the cylinder.
4. Follow the procedure to unlock the counterweight and retract the counterweight.
5. Follow the procedure to unlock the counterweight and retract the counterweight.

Counterweight Hinge Pins - Lubricate

⚠ WARNING

Use a stable work platform placed in a secure location when lubricating the counterweight hinge pins. If a secure location is not available, use the appropriate safety equipment to prevent falling off of the machine. Failure to work from a secure location may result in injury or death from a slip or a fall.

Lubricate the eight pins through the grease fittings. There are four grease fittings that face toward the front of the machine and there are four grease fittings that face toward the rear of the machine.

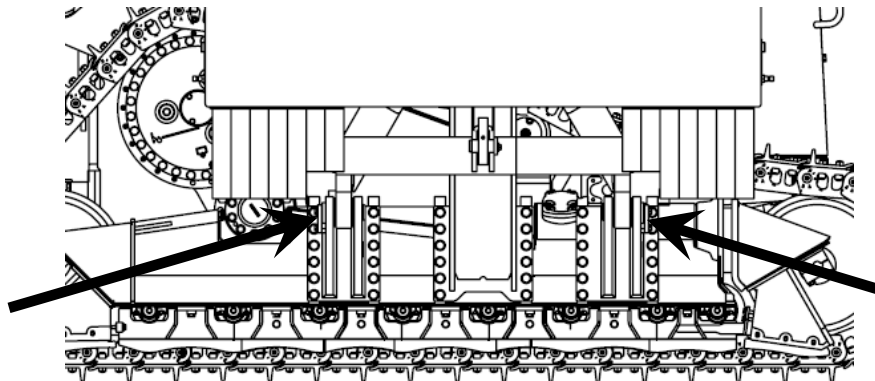

Figure 38: Counterweight hinge pins located right side of machine

Note: If the counterweight is fully extended, install the counterweight lock lever in order to lubricate the counterweight hinge pins. Refer to Operation and Maintenance Manual, “Counterweight Lock Lever” for more details.

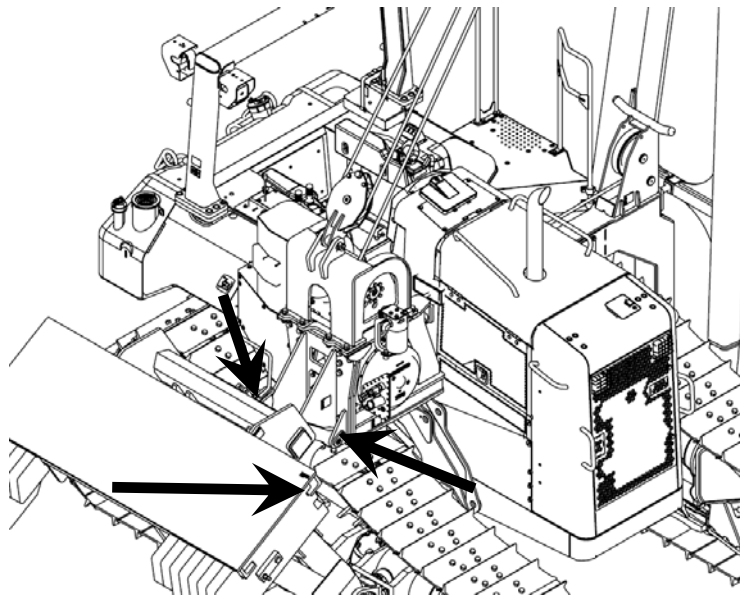

Figure 39: Counterweight hinge pins lubrication points

Fairlead Sheave – Lubricate



Figure 40: Fairlead sheave lubrication points

Lubricate one fitting in the lower pin (1) and lubricate one fitting in the upper sheave (2).

Hook and Wire Cable – Inspect

Inspect the Hook

Inspect the hook frequently. The inspections should include observation of the hook during operation of the hook. A designated person determines if the conditions that are found during the inspections constitute a hazard. The designated person will determine if a more detailed inspection is required.

- Inspect the hook for any distortion such as bends in the hook or twists in the hook.
- Inspect the hook for any wear.
- Inspect the hook for cracks, nicks, or gouges.
- If a latch is provided, inspect the latch. Make sure that the latch engages properly. Inspect the latch for any damage. Make sure that the latch is not malfunctioning.
- Inspect the hook assembly and the means for securing the hook assembly.
- For additional information on the proper maintenance and on the proper inspection of hooks, refer to "American National Standard Institute ANSI/ASME B30.14" or ISO 8813.

Inspect Wire Cable - Boom and Hook lines

Make a visual inspection of all running cables that are in continuous use. Make the inspection of the running cables on a daily basis before the machine is placed in operation. Inspect all of the cables on a monthly basis.

All inspections shall be performed by a designated person. Keep a dated report of the condition of the cable on file in a location that is available to designated personnel. Perform a close inspection of the sections of the cable that are normally hidden during the visual inspection and the maintenance inspection. (This includes the sections of the cable that pass over the sheaves.) These points are the sections of the cable that are most likely to fail.

Note any deterioration that results in a notable loss of the original strength. (See the conditions that are described below.) Determine if further use of the cable will constitute a hazard.

Inspect the cable on a daily basis for the following conditions:

- Inspect the cable for a reduction in the diameter of the cable below the nominal diameter. A loss of support in the cored wire of the cable may be caused by internal corrosion, external corrosion, or wear of the outside wires.
- Inspect the cable for broken outside wires. Check for the degree of distribution of the broken outside wires. Check for the concentration of outside broken wires.
- Inspect the cable for worn outside wires.
- Inspect the cable for corroded wires and for broken wires at the connection on the wire cable end.
- Inspect the cable end for connections that are corroded, cracked, bent, worn, or improperly installed.
- Inspect the cable for sections that are crushed or kinked and for any loose wire strands.

Excessive wear or broken wires may occur in sections of the cable that are in contact with saddles, equalizer sheaves, or other sheaves. Excessive wear or broken wires can also occur when cable travel is limited. Take care to inspect the ropes at these locations.

When a machine is shutdown for a month or more, inspect all of the cables thoroughly. When a side boom machine has been in storage for a month or more inspect all of the cables thoroughly. The inspection should be completed before the machine is returned to operation.

The inspection should be for all types of deterioration. The inspection should be performed by a designated person or by an authorized person. The authorized person's approval is required for further use of the cable.

A dated report on the condition of the cable should be kept on file.

Take care in the inspection of cable that is resistant to rotation.

Any new poured socket or swaged socket assembly that is used as a standing cable (guy) shall be proof tested. Test the cable to the lift capacity of the side boom machine or to the manufacturer's recommendation.

Never give the cable a rating that is greater than 50 percent of the wire rope's nominal strength or of the structural strand's nominal strength.

Note: For additional information on the proper maintenance and on inspection of the cable, refer to "American National Standards Institute ANSI/ASME B30.14" or ISO 8813.

Hook Load Line – Install



Do not operate or work on this equipment unless you have read and understand the instructions and warnings in the Operation and maintenance Manual. Failure to follow the instructions or heed the warnings could result in injury or death. Proper care is your responsibility.



Personal injury or death can result from worn wire rope cable. Worn or frayed cable could break causing injury. Check the wire rope cable. If cable is worn or is frayed install new cable. Wear gloves when handling the wire rope cable.

NOTICE

Make sure that the construction of the wire rope is 6x25 IWRC XIPS (Independent Wire Rope Core, eXtra Improved Plow Steel) conforming to ISO 2408. Also, the established grade of the wire rope is the improved plow bolt (steel), 26670 kg (58,800 lb) minimum breaking strength.

SPECIFICATIONS (WIRE ROPE) Hook Load Line Cable		
Boom Length	Diameter	Length
6.1 m (20 ft)	19.05 mm (0.75 inch)	45.7 m (150 ft)

Table 7: Hook load line wire rope specifications

1. Lower the boom to the horizontal position.
2. Remove the anchor for the wire rope from the drum for the hook. Remove the old wire rope.
3. Unroll the new wire rope from the spool.

Note: Weld the cable ends in order to prevent fraying.

NOTICE

Unroll all of the cable from the spool. Lay the wire rope on a flat surface. Never lift the wire rope off the spool in coils.

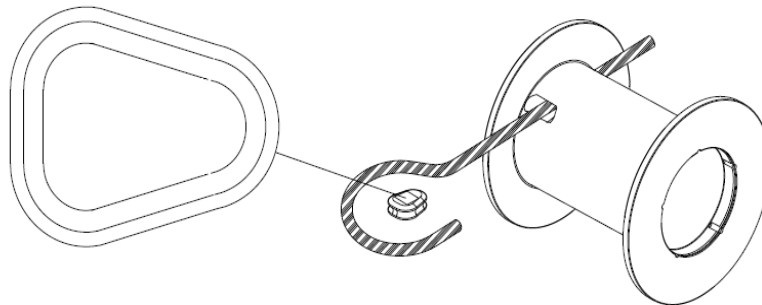

Figure 41: Installing hook load line, cable anchor assembly

4. Install the cable into the small slot and through the larger slot in the drum for the boom.
 - a. Start with inserting the cable anchor into the longer slot as far as allowed.
 - b. Make a loop with the end of the wire rope and insert the end into the slot past the cable anchor.
 - c. Pull the wire rope until the wire rope and anchor assembly are securely seated inside the slot.
5. Wind one half of the wire rope on the drum. Wind the wire rope evenly across the drum.
6. Install the hook load line from the winch drum onto the sheave blocks per the figure below:

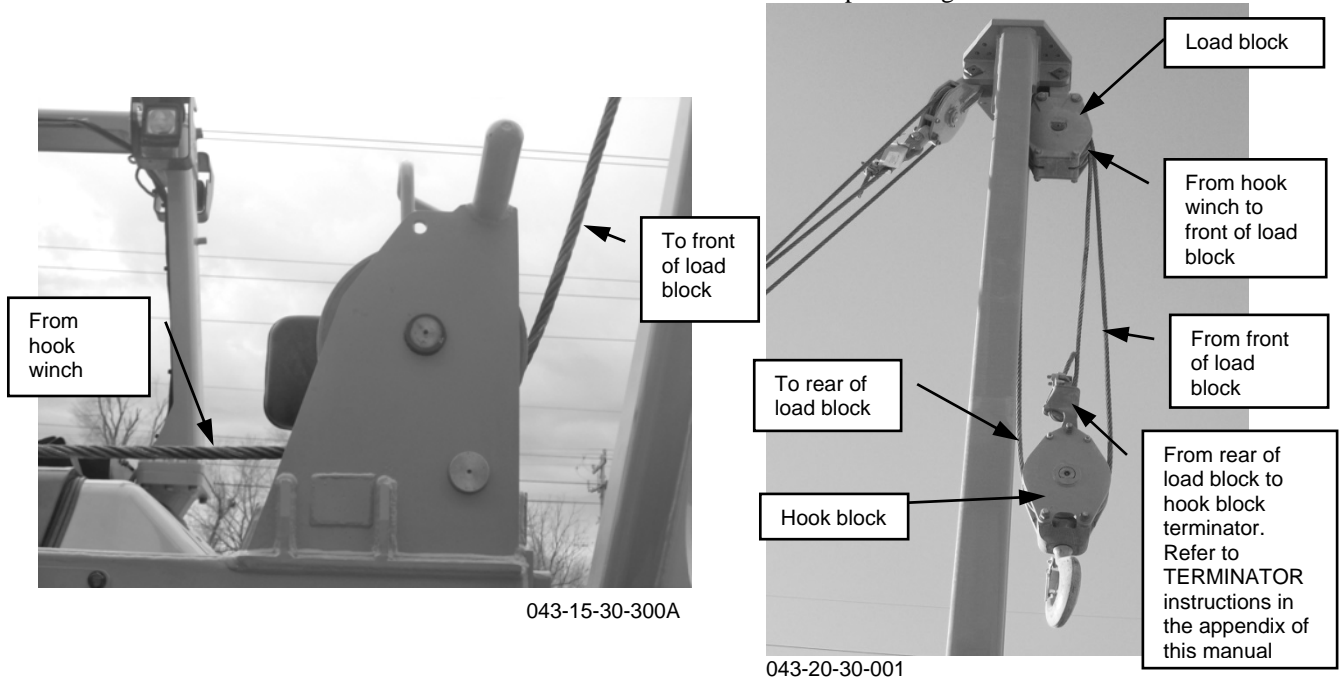
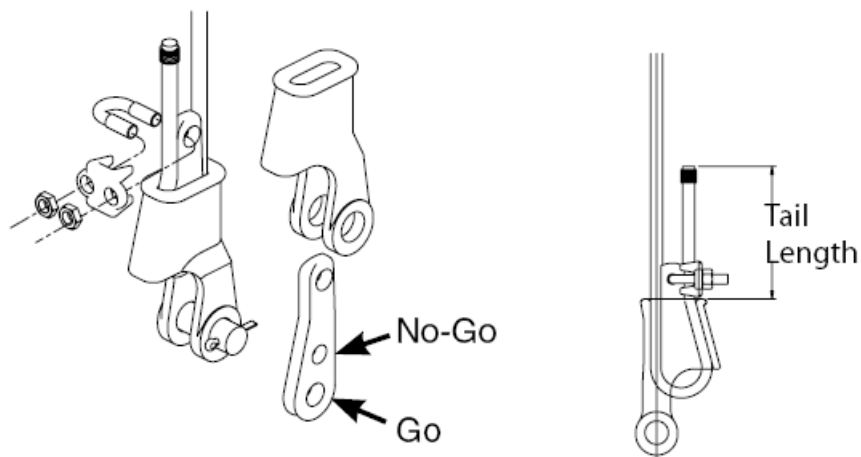

Figure 42: Installing hook load line

7. Secure the line to the line terminator on the Luff block, as per Terminator instructions outlined in the **Appendix**.



NOTE: Do not clamp the loaded end of the wire rope and the tail end of the wire rope together. Refer to TERMINATOR instructions in the appendix of this manual.

8. Apply a test first load in order to seat wedge.

THIS PAGE INTENTIONALLY LEFT BLANK

Hook Winch: Freefall, Brake, Gearbox oil - Change

WARNING

Do not use EP type gear lubes in the brake section of this winch. EP lubes may prevent the brake-clutch from locking up, which, in turn causes the load to fall, resulting in property damage, personal injury, or death.

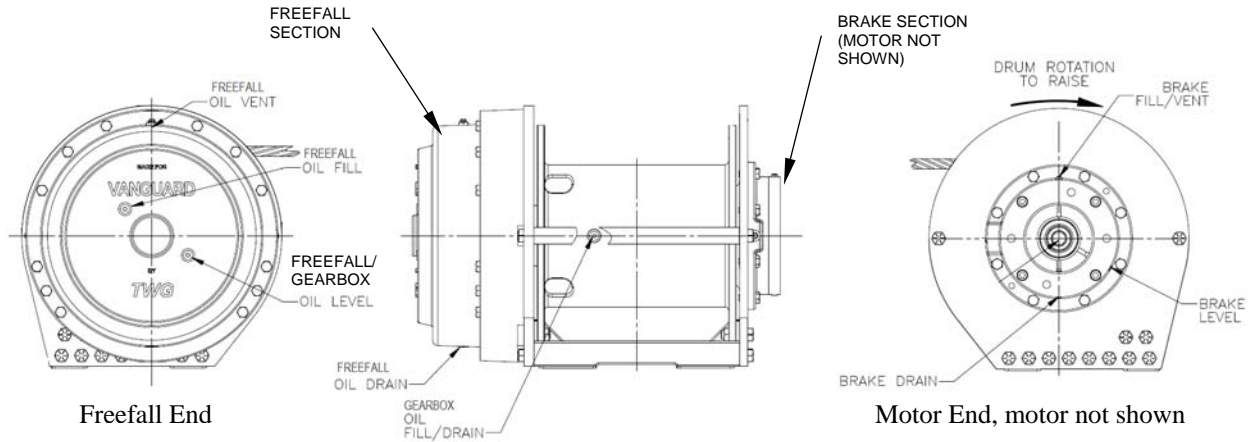

Figure 43: Hook Winch oil change Ports

FREEFALL/GEARBOX oil change:

- Drain the fluid from the FREEFALL section. Remove the freefall drain plug "FREEFALL DRAIN" (SAE # 6) at the bottom of the FREEFALL housing section.
- Drain the oil into a suitable container.
- After the fluid has drained, replace the plug "FREEFALL DRAIN".
- Examine the oil for significant signs of metallic particles and/or burning. Significant signs of particles/burning could indicate that additional winch servicing is required.
- Dispose of the used oil in a proper manner.
- Drain the fluid from the GEARBOX section. Rotate the winch drum so that the fill/drain plug "GEARBOX FILL/DRAIN" (SAE #6) is at the bottom. Remove the plug.
- Drain the oil into a suitable container.
- After the fluid is drained, Rotate the drum so that the "GEARBOX FILL/DRAIN" is now at the top.
- Examine the oil for significant signs of metallic particles and/or burning. Significant signs of particles/burning could indicate that additional winch servicing is required.
- Remove the "FREEFALL FILL" plug (SAE # 6).
- Add the correct quantity and type of gearbox/freefall oil through the "FREEFALL FILL", see the Lubricant Viscosities and Lubricant Capacities sections in this manual for recommended oil type and grade for your application.
- Reinstall the "FREEFALL FILL" plug.
- Add the correct quantity and type of gearbox/freefall oil, through the "GEARBOX FILL/DRAIN", see the Lubricant Viscosities and Lubricant Capacities sections in this manual for recommended oil type and grade for your application.
- Reinstall the "GEARBOX FILL/DRAIN" plug.

FREEFALL/GEARBOX oil level:

- The "FREEFALL/GEARBOX LEVEL" plug on the freefall housing serves to monitor the oil level for both the drum and freefall cavities. The cavities are drained and filled separately due to the rate at which fluid traverses the sections, however they are not separate and can be monitored from the same "FREEFALL/GEARBOX LEVEL" port.
- The oil level should be just below the "FREEFALL/GEARBOX LEVEL" port.
- If the oil level drops frequently or oil leakage is detected during an inspection, maintenance should be performed to correct any problems.

BRAKE oil change:

- Drain the brake section by removing the drain plug "BRAKE DRAIN" under the motor along with the vent "BRAKE FILL/VENT" above the motor.
- Drain the oil into a suitable container.
- Reinstall the drain plug "BRAKE DRAIN".
- Inspect the oil for signs of metallic particles and/or burning. Significant signs of particles/burning could indicate that additional winch servicing is required.
- Add the correct quantity of non-EP oil, see the Lubricant Capacities section in this manual for recommended oil type and grade for your application.
- Reinstall the vent "BRAKE FILL/VENT".

BRAKE oil level:

- Monitor the brake oil level at the "BRAKE LEVEL" port. The oil level should be just below the port.
- If the oil level drops frequently or oil leakage is detected during an inspection, maintenance should be performed to correct any problems.

Boom Winch: Freefall, Brake, Gearbox oil - Change



Do not use EP type gear lubes in the brake section of this winch. EP lubes may prevent the brake-clutch from locking up, which, in turn causes the load to fall, resulting in property damage, personal injury, or death.

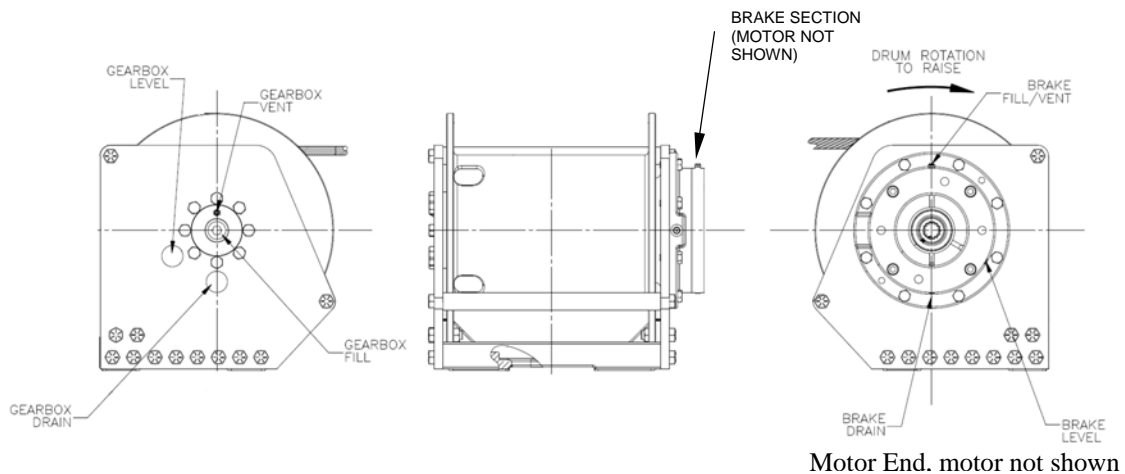

Figure 44: Hook Winch oil change Ports

GEARBOX oil change:

- Gearbox oil is drained by first removing the drain plug by rotating the drum so that the plug is visible through the lower hole in the side plate "GEARBOX DRAIN".
- Screw in a piece of 1" pipe to allow the oil to drain, and then with a hex wrench remove the drain plug located inside of the 1" pipe.
- Drain the oil into a suitable container.
- Examine the used oil for signs of significant metal deposits and then dispose of it in a proper manner.
- Remove the 1" pipe. Rotate the drum so that the port is visible through the upper hole in the side plate "GEARBOX LEVEL".
- With a hex wrench, remove the fill plug located in the center of the output shaft "GEARBOX FILL".
- Install a 1" pipe with elbow through the hole in the output shaft "GEARBOX FILL".
- Add the correct quantity and type of oil to the gearbox, see the Lubricant Capacities section in this manual for recommended oil type and grade for your application.
- Remove the pipe and elbow then replace all plugs "GEARBOX FILL" and "GEARBOX LEVEL".

GEARBOX oil level:

- Monitor the gearbox oil level at the "GEARBOX LEVEL" port. The oil level should be just below the port.
- If the oil level drops frequently or oil leakage is detected during an inspection, maintenance should be performed to correct any problems.

BRAKE oil change:

- Drain the brake section by removing the drain plug "BRAKE DRAIN" under the motor along with the vent "BRAKE FILL/VENT" above the motor.
- Drain the oil into a suitable container.
- Inspect the oil for signs of metallic particles and/or burning and reinstall the drain plug "BRAKE DRAIN".
- Add the correct quantity of non-EP oil, see the Lubricant Capacities section in this manual for recommended oil type and grade for your application.
- Reinstall the vent "BRAKE FILL/VENT".

BRAKE oil level:

- Monitor the brake oil level at the "BRAKE LEVEL" port. The oil level should be just below the port.
- If the oil level drops frequently or oil leakage is detected during an inspection, maintenance should be performed to correct any problems.

Hydraulic System Oil - Change

Refer to the specific tractor Operation and Maintenance Manual "Hydraulic System Oil - Change" for complete requirements and procedures.



At operating temperature, the hydraulic tank is hot and under pressure. Hot oil and components can cause personal injury. Do not allow hot oil or components to contact skin. Remove the filler cap only when the engine is stopped, and the filler cap is cool enough to touch with your bare hand. Remove the filler cap slowly in order to relieve pressure.

NOTICE

Care must be taken to ensure that fluids are contained during performance of inspection, maintenance, testing, adjusting and repair of the product. Be prepared to collect the fluid with suitable containers before opening any compartment or disassembling and component containing fluids.

Dispose of all fluids according to local regulations and mandates.

Operate the machine in order to warm the oil.

Fully retract the counterweight

Park the machine on level ground. Engage the parking brake and stop the engine.

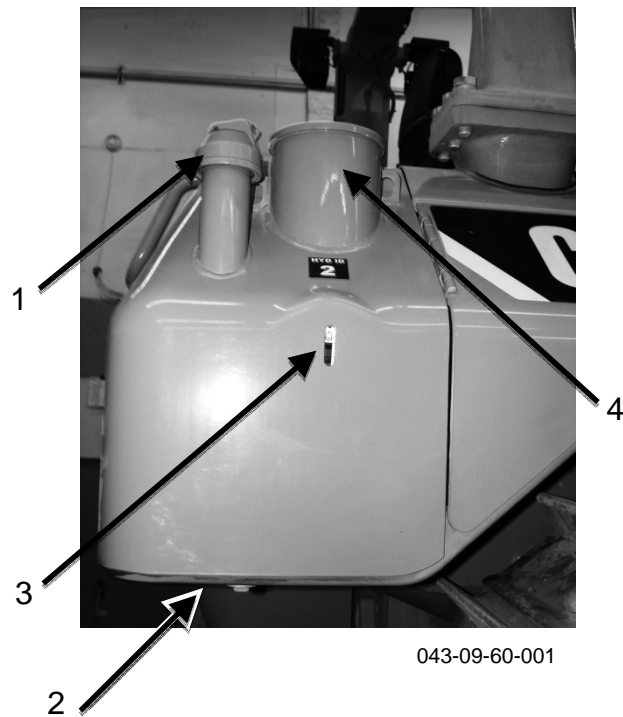

Figure 45: Hydraulic tank filler cap

Remove the hydraulic tank filler cap (1) slowly in order to relieve any pressure.

1. Wash the filler strainer and the filler cap in a clean nonflammable solvent.
2. Remove oil drain plug (2).
3. Attach a hose to a 1 inch NPT pipe nipple. This 1 inch NPT pipe nipple should have a length of 100 mm (4 inch).
4. Install the pipe nipple into the drain plug opening.
5. Rotate the pipe nipple clockwise in order to open the internal drain valve. Allow the oil to drain into a suitable container.
6. Remove the pipe nipple. The valve for the hydraulic tank will close.
7. Clean drain plug (2) and install drain plug (2). Tighten drain plug (2) to a torque of 68 ± 7 Nm (50 ± 5 lbft).
8. See the Operation and Maintenance Manual, Maintenance and Lubrication section, "Hydraulic System Oil Filter – Replace". Change the hydraulic system filter (4).



043-05-60-002

5

Right hand rear
fender door

Figure 46: Winch Drains and Case Drain Filter

9. See the Operation and Maintenance Manual, Maintenance and Lubrication section, “Hydraulic System Case Drain Filter – Replace”. Change the hydraulic system case drain filter (5).
10. Install the filler strainer.
11. See the Operation and Maintenance Manual, “Lubricant Capacities (Refill) in order to determine the amount of hydraulic oil that is needed to fill the hydraulic oil tank. Fill the hydraulic oil tank.
12. Inspect the filler cap gasket. Install a new gasket if damage or wear is evident. Install the filler cap.
13. Start the engine. Run the engine for a few minutes. Check for leaks.

14. Flush the boom stop PX line at the main control manifold "PX" connection (8), slowly raise the boom winch up. Do not allow the boom (if installed) to contact the boom kickout rod or the left-hand frame. Lower the boom if required. Continue to cycle the boom winch up until the old oil in the lines is fully flushed out with new oil. Tighten the PX connection (6).

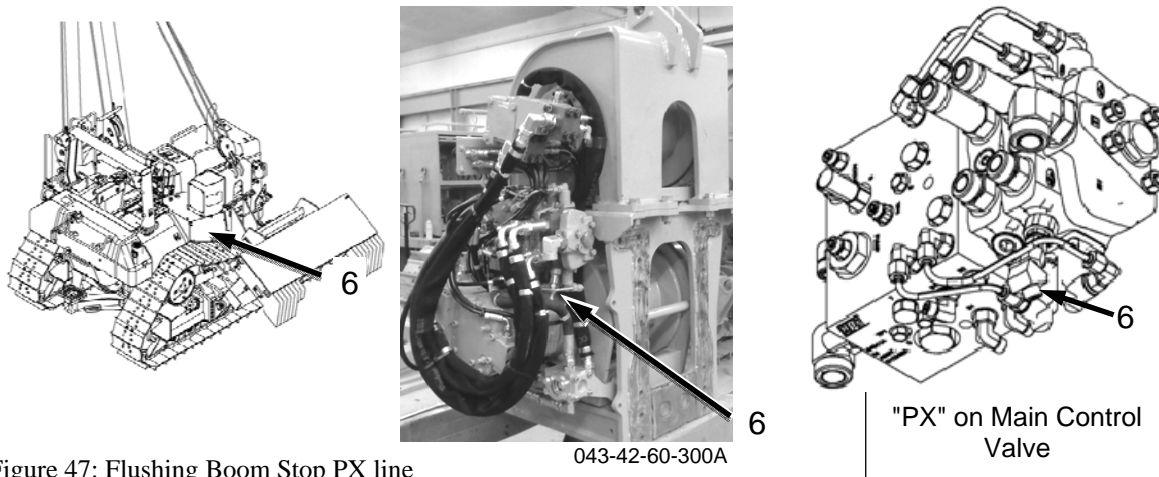

Figure 47: Flushing Boom Stop PX line

15. Flush the boom stop drain line connection (8) at the return manifold. Manually actuate the boom stop valve (9) while slowly raising the boom winch, the winch should not turn. Flush the boom stop drain line until the old oil in the lines is fully flushed out with new oil. Tighten the boom stop drain line connection (8).

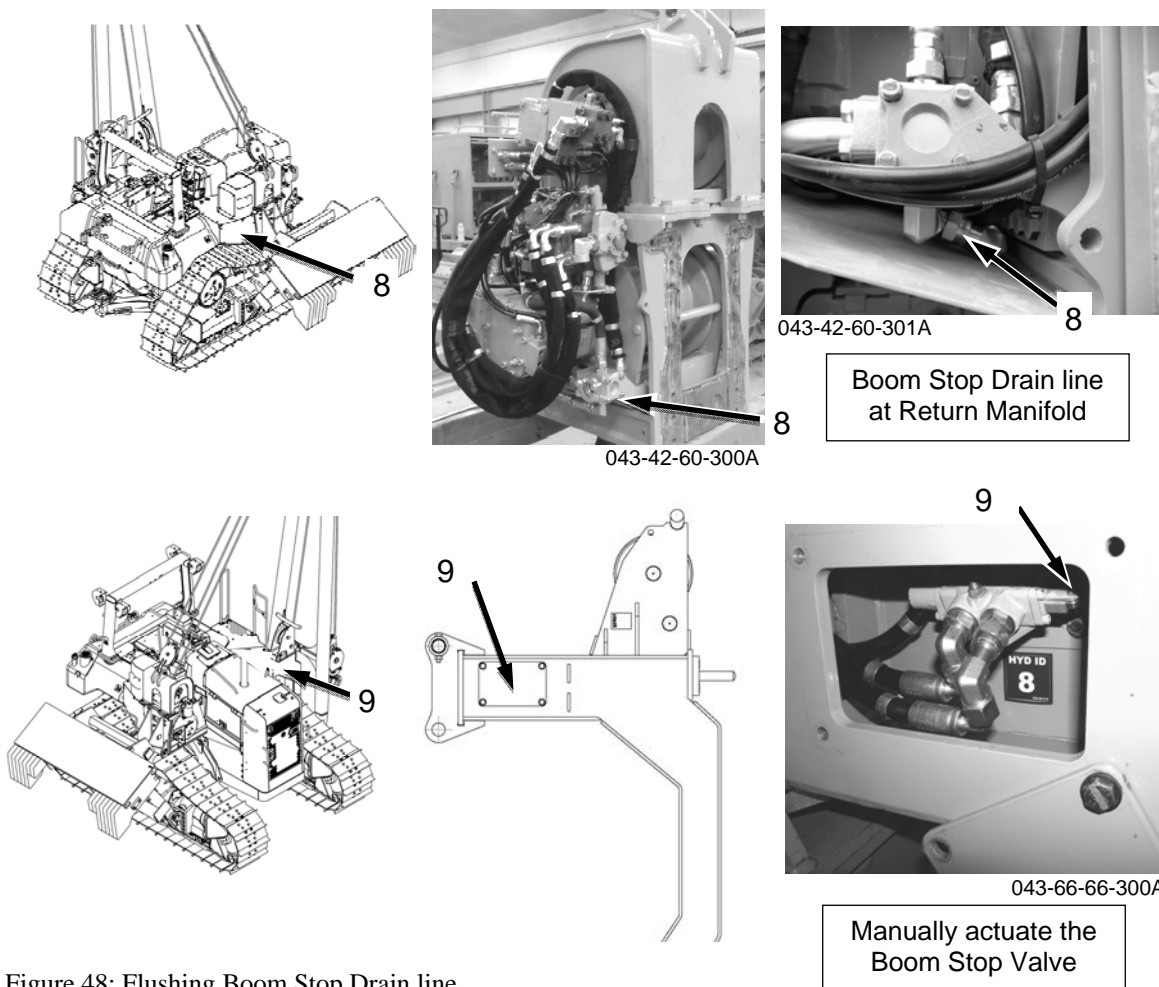

Figure 48: Flushing Boom Stop Drain line

16. Maintain the oil level to the "FULL" mark in sight gauge (3). Add oil, if necessary. Stop the engine.

Hydraulic System Oil Filter - Replace

⚠ WARNING

At operating temperature, the hydraulic tank is hot and under pressure. Hot oil and components can cause personal injury. Do not allow hot oil or components to contact skin. Remove the filler cap only when the engine is stopped, and the filler cap is cool enough to touch with your bare hand. Remove the filler cap slowly in order to relieve pressure.

1. Slowly remove the hydraulic tank filler cap (3) in order to relieve the system pressure.
2. Open the access door that is located on the right side of the machine next to the filler cap.

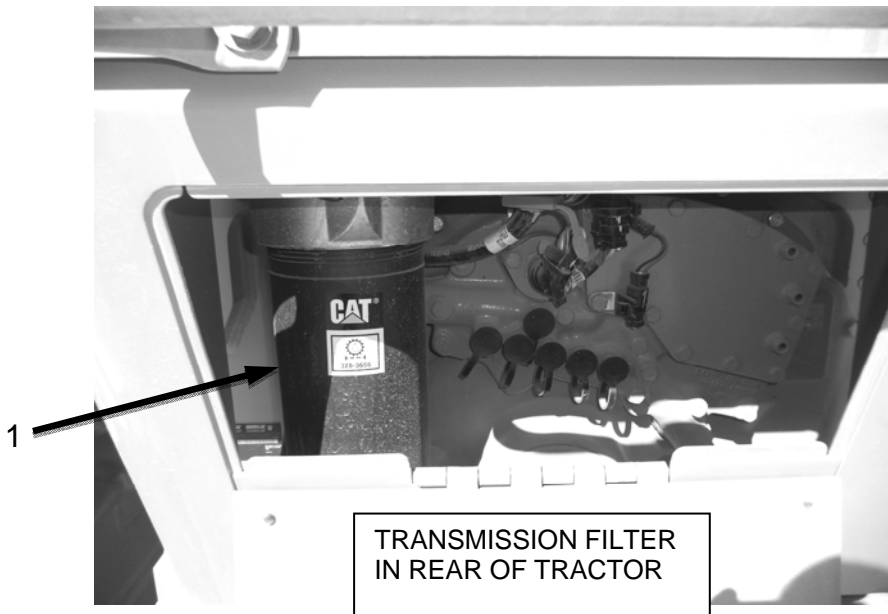

Figure 49: Filter locations

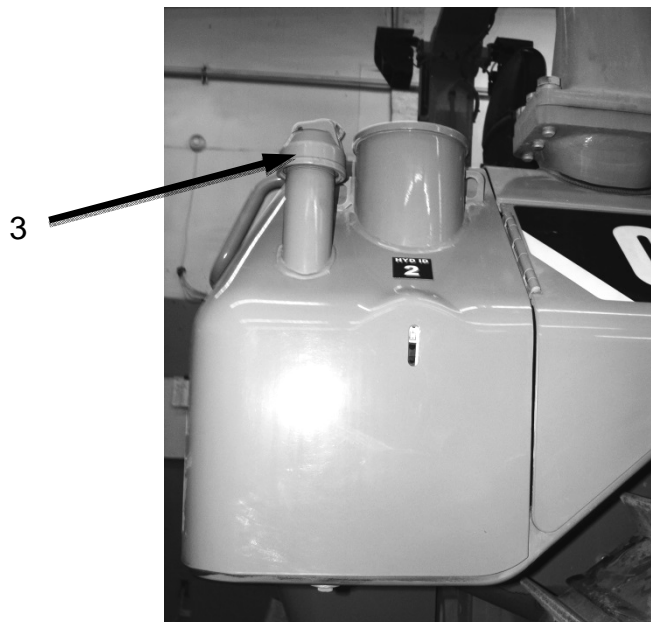
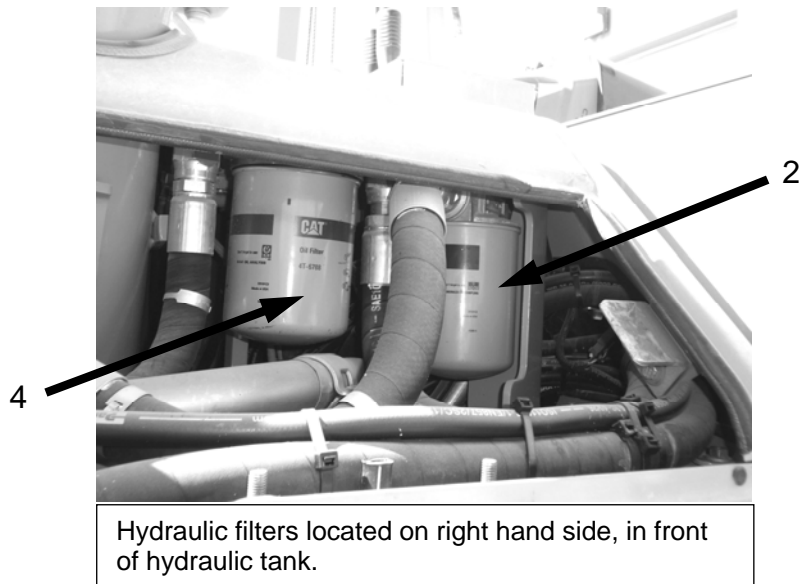

Figure 50: Filter locations



043-05-60-002

Figure 51: Filter location

- (1) Transmission oil filter
- (2) Hydraulic system filter
- (3) Hydraulic Tank filler cap
- (4) Case drain filter pipelayer

3. Remove filter (1, 2, and 4).

Note: Remove case drain hydraulic filter (1). Discard the used filter. Remove the hydraulic system filter (2). Discard used filter. Replace both of the filters at the same time.

4. Inspect the seal on the filter housings for filter (1,2, and 4). If the seals are damaged or worn, install new seals. Install a new filter element into the filter housing for (1, 2,and 4).

Hydraulic System Oil Level – Check



At operating temperature, the hydraulic tank is hot and under pressure. Hot oil and components can cause personal injury. Do not allow hot oil or components to contact skin. Remove the filler cap only when the engine is stopped, and the filler cap is cool enough to touch with your bare hand. Remove the filler cap slowly in order to relieve pressure.

The hydraulic tank is on the right rear corner of the machine.

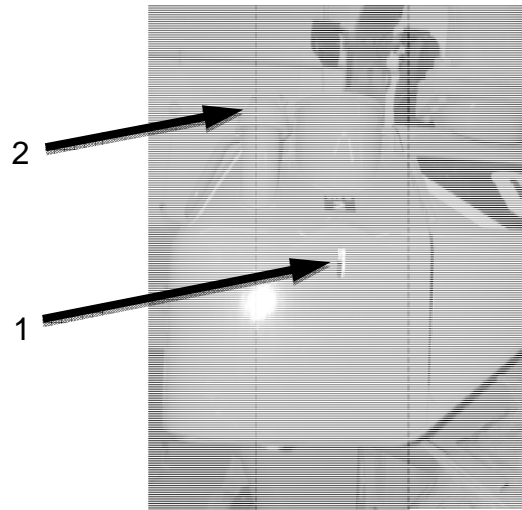

043-05-60-004

Figure 52: Hydraulic Tank

1. The counterweight should be fully retracted when you check the oil level.
2. Maintain the oil level to the “FULL” mark in sight gauge (1).
3. If the hydraulic system requires additional hydraulic oil, remove filler cap (2) and add oil. Clean filler cap (2) and install filler cap (2).

Hydraulic System Oil Sampling

Refer to the tractor’s operation and maintenance manual for the specific procedures regarding Hydraulic System Sampling.

Oil Filter Inspection

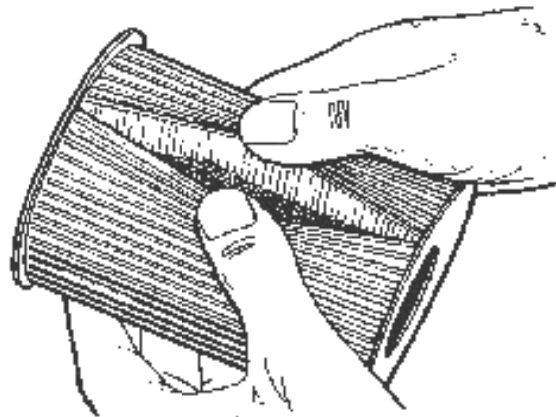

Figure 53: Oil filter.

Use a Filter Cutter - CAT# 4C-5084, or similar to cut the filter element open. Spread apart the pleats and inspect the element for metal and other debris. An excessive amount of debris in the filter element can indicate a possible failure.

If metals are found in the filter element, a magnet can be used to differentiate between ferrous metals and nonferrous metals. Ferrous metals would indicate wear on steel parts and on cast iron parts. Non ferrous metals would indicate wear of the brass or aluminum part of the hydraulics such as main bearings, pump sleeves, etc.

Small amounts of debris may be found in the filter element. This could be caused by friction and normal wear. Consult your Caterpillar dealer in order to arrange for further analysis if an excessive amount of debris is found.

Using an oil filter element that is not recommended by Caterpillar could result in severe damage. This could result in larger particles in unfiltered oil. These particles could enter the system and cause damage.

Sheave Block Bearing - Lubricate

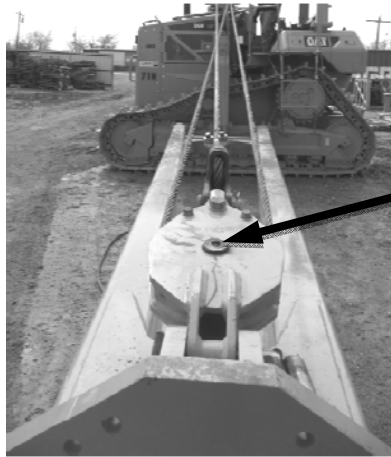

043-20-30-003

Figure 54: Rigging Grease Nipples

Lubricate (1) in the luff block.

Lubricate fitting in the pins for boom luff block (2) and load block (3).

Lubricate pin (4) in load sheave block and the pin (5) in the hook sheave block.

Lubricate pins (6) & (7) on tail block.



043-20-30-002

Figure 55: Rigging Grease Nipples – Tail Block

Tractor Maintenance

Refer to the tractor's operation and maintenance manual for the specific procedures regarding complete Tractor Maintenance.

Appendix - Terminator Instructions

TERMINATOR™ WARNINGS AND APPLICATION INSTRUCTIONS

Extended Wedge Socket Assembly U.S. Patent No. 5,553,360 and Canada Patent No. 2,217,004

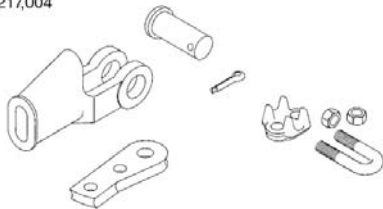

S-421T / US-422T
"TERMINATOR"™

NOTE: The design of the basket for the S-421T 1-1/4" TERMINATOR™ Wedge Socket does not allow proper fit to the old style Crosby S-421W wedge (see Fig. 1). **Do not assemble or use.**

The design of the basket for each US-422T TERMINATOR™ Wedge Socket does not allow proper fit to the old style UWO-422 wedge (See Fig. 1). **Do not assemble or use.**

All S-421T and US-422T TERMINATOR™ baskets are marked with a capital "T" or TERMINATOR™.

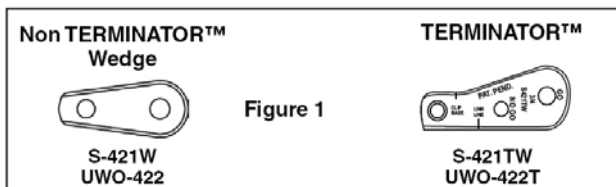

QUIC-CHECK® "Go" and "No-Go" features cast into wedge. The proper size wire rope is determined when the following criteria are met:

1. The wire rope shall pass thru the "Go" hole in the wedge.
2. The wire rope shall NOT pass thru the "No-Go" hole in the wedge.



Important Safety Information – Read and Follow Inspection/Maintenance Safety

- Always inspect socket, wedge and pin before using.
- Do not use part showing cracks.
- Do not use modified or substitute parts.
- Repair minor nicks or gouges to socket or pin by lightly grinding until surfaces are smooth. Do not reduce original dimension more than 10%. Do not repair by welding.
- Inspect permanent assemblies annually, or more often in severe operating conditions.
- Do not mix and match wedges or pins between models or sizes.
- Always select the proper wedge and socket for the wire rope size.

Assembly Safety

- Use only with standard 6 to 8 strand wire rope of designated size. For intermediate size rope, use next larger size socket. For example: When using 9/16" diameter wire rope use a 5/8" size Wedge Socket Assembly. Welding of the tail on standard wire rope is not recommended. Seizing of the tail is preferred following the recommended practices of the wire rope manufacturer. The tail length of the dead end should be a minimum of 6 rope diameters but not less than 6" (See Figure 2).
- **To use with Rotation Resistant wire rope** (special wire rope constructions with 8 or more outer strands) ensure that the dead end is welded, brazed or seized before inserting the wire rope into the wedge socket to prevent core slippage or loss of rope lay. Seizing of the tail is preferred following the recommended practices of the wire rope manufacturer. The tail length of the dead end should be a minimum of 20 rope diameters but not less than 6" (See Figure 2).
- Properly match socket, wedge and clip (See Table 1) to wire rope size.

- Align live end of rope, with center line of pin.(See Figure 2)
- Secure dead end section of rope. (See Figure 2)
- Tighten nuts on clip to recommended torque. (See Table 1)
- Do not attach dead end to live end or install wedge backwards (See Fig. 3).
- Use a hammer to seat Wedge and Rope as deep into socket as possible before applying first load.

WARNING

- **Loads may slip or fall if the Wedge Socket is not properly installed.**
- **Load misapplied in direct contact with the wedge can dislodge the wedge and cause loss of load.**
- **A falling load can seriously injure or kill.**
- **Read and understand these instructions before installing the Wedge Socket.**
- **Do not side load the Wedge Socket.**
- **Apply first load to fully seat the Wedge and Wire Rope in the socket. This load should be of equal or greater weight than loads expected in use.**
- **Do not interchange wedges between S-421T and US422T or between sizes.**
- **Do not assemble an old style 1-1/4" (30-32mm)S-421W wedge into an S-421T 1-1/4" (30-32mm) TERMINATOR™ basket.**
- **Do not assemble an old style UWO-422 wedge into a US-422T TERMINATOR™ basket.**

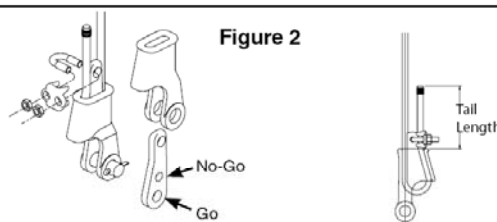

*Tail Length	
Standard 6 to 8 Strand Wire Rope	Rotation Resistant Wire Rope
A minimum of 6 rope diameters, but not less than 6"	A minimum of 20 rope diameters, but not less than 6"

TABLE 1								
Rope Size (in.)	3/8	1/2	5/8	3/4	7/8	1	1-1/8	1-1/4
Clip Size (in.)	3/8	1/2	5/8	3/4	7/8	1	1-1/8	1-1/4
* Torque Ft./lbs.	45	65	95	130	225	225	225	360

* The tightening torque values shown are based upon the threads being clean, dry, and free of lubrication.

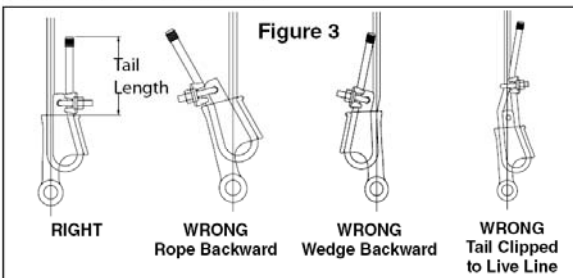

Operating Safety

- Apply first load to fully seat the Wedge and Wire Rope in the socket. This load should be of equal or greater weight than loads expected in use.
- Efficiency rating of the Wedge Socket termination is based upon the catalog breaking strength of Wire Rope. The efficiency of a properly assembled Wedge Socket is 80%.
- During use, do not strike the dead end section or wedge with any other elements of the rigging (Called two blocking).
- Do not allow a direct load to contact the wedge.

