

# **BOMAG**

**FAYAT GROUP**

## **Operating Instruction Maintenance Instruction**

*Original Operating Instructions*

### **BMP 8500**

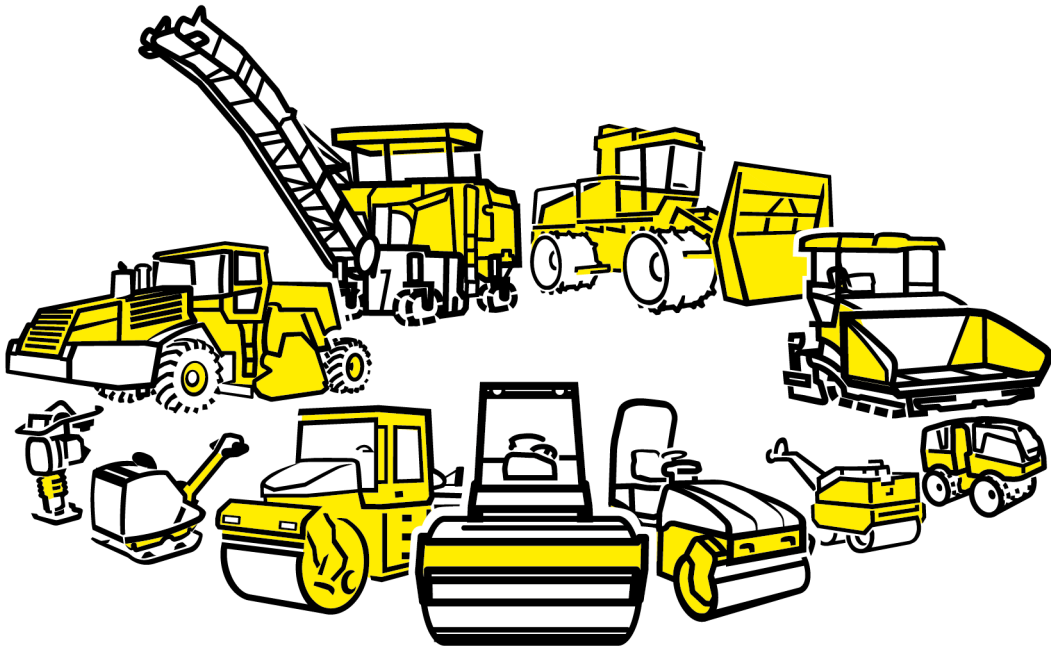

S/N 101 720 13 1001>

---

## **Multi-purpose compactor**

---

 **WARNING:** Breathing diesel engine exhaust exposes you to chemicals known to the State of California to cause cancer and birth defects or other reproductive harm.

- Always start and operate the engine in a well-ventilated area.
- If in an enclosed area, vent the exhaust to the outside.
- Do not modify or tamper with the exhaust system.
- Do not idle the engine except as necessary.

For more information go to [www.P65warnings.ca.gov/diesel](http://www.P65warnings.ca.gov/diesel).

 **WARNING:** Crude oil, gasoline, diesel fuel and other petroleum products can expose you to chemicals including toluene and benzene, which are known to the State of California to cause cancer and birth defects or other reproductive harm.

These exposures can occur in and around oil fields, refineries, chemical plants, transport and storage operations such as pipelines, marine terminals, tank trucks and other facilities and equipment.

For more information go to [www.P65Warnings.ca.gov/petroleum](http://www.P65Warnings.ca.gov/petroleum).

## Table of contents

<b>1</b>	<b>Introduction</b> .....	<b>9</b>
	<b>1.1 Foreword</b> .....	<b>10</b>
	<b>1.2 Machine type plate and engine type plate</b> .....	<b>12</b>
<b>2</b>	<b>Technical data</b> .....	<b>13</b>
	<b>2.1 Noise data</b> .....	<b>17</b>
<b>3</b>	<b>Concerning your safety</b> .....	<b>19</b>
	<b>3.1 Basic prerequisites</b> .....	<b>20</b>
	3.1.1 General.....	20
	3.1.2 Explanation of signal words used:.....	20
	3.1.3 Personal protective equipment.....	21
	3.1.4 Intended use.....	22
	3.1.5 Improper use.....	23
	3.1.6 Estimated service life of the machine.....	23
	<b>3.2 Definition of responsible persons</b> .....	<b>24</b>
	3.2.1 Operating company.....	24
	3.2.2 Expert / qualified person.....	24
	3.2.3 Driver / operator.....	24
	<b>3.3 Basic safety regulations for safe operation</b> .....	<b>26</b>
	3.3.1 Remaining dangers, remaining risks.....	26
	3.3.2 Regular safety inspections.....	26
	3.3.3 Modifications and alterations to the machine.....	26
	3.3.4 Damage, defects, misuse of safety devices.....	26
	<b>3.4 Handling fuels and lubricants</b> .....	<b>27</b>
	3.4.1 Preliminary remarks.....	27
	3.4.2 Safety regulations and environmental protection regulations for handling diesel fuel.....	28
	3.4.3 Safety regulations and environmental protection regulations for handling oil.....	29
	3.4.4 Safety regulations and environmental protection regulations for handling hydraulic oil.....	30
	3.4.5 Safety regulations and environmental protection regulations for handling coolants.....	31
	3.4.6 Safety regulations and environmental protection regulations for handling battery acid.....	32
	<b>3.5 Loading/transporting the machine</b> .....	<b>33</b>
	<b>3.6 Start-up procedure</b> .....	<b>34</b>
	3.6.1 Prior to start-up.....	34
	3.6.2 Starting the engine.....	34
	3.6.3 Starting the engine with jump leads.....	35
	<b>3.7 Operation with radio remote control</b> .....	<b>36</b>
	<b>3.8 Driving the machine; working operation</b> .....	<b>37</b>
	3.8.1 Persons in the danger zone.....	37
	3.8.2 Driving the machine.....	37
	3.8.3 Driving up and down slopes.....	37
	3.8.4 Cross slope.....	37
	3.8.5 Working with vibration.....	38
	3.8.6 Parking the machine.....	38
	<b>3.9 Refuelling</b> .....	<b>39</b>
	<b>3.10 Emergency procedures</b> .....	<b>40</b>

## Table of contents

3.10.1	Actuating the emergency stop switch.....	40
3.10.2	Disconnecting the battery.....	40
3.10.3	Recovering the machine.....	40
<b>3.11</b>	<b>Maintenance work.....</b>	<b>41</b>
3.11.1	Preliminary remarks.....	41
3.11.2	Working on hydraulic lines.....	41
3.11.3	Working on the engine.....	41
3.11.4	Maintenance work on electric components and battery.....	42
3.11.5	Cleaning work.....	42
3.11.6	Measures for longer shut-down periods.....	42
3.11.7	After maintenance work.....	43
<b>3.12</b>	<b>Repair.....</b>	<b>44</b>
<b>3.13</b>	<b>Signage.....</b>	<b>45</b>
<b>4</b>	<b>Indicators and control elements.....</b>	<b>53</b>
4.1	<b>ECONOMIZER display.....</b>	<b>54</b>
4.2	<b>Operating mode toggle switch.....</b>	<b>55</b>
4.3	<b>Display module.....</b>	<b>56</b>
4.4	<b>Main battery switch.....</b>	<b>57</b>
4.5	<b>Remote control.....</b>	<b>58</b>
4.5.1	Steering lever.....	58
4.5.2	Vibration pre-selection toggle switch.....	59
4.5.3	Toggle switch for travel ranges.....	59
4.5.4	Engine speed toggle switch.....	59
4.5.5	Travel lever.....	60
4.5.6	Starter switch.....	60
4.5.7	Start button.....	60
4.5.8	Vibration toggle switch.....	61
4.5.9	Emergency stop switch.....	61
4.5.10	Button for warning horn.....	61
4.5.11	Radio operation control light.....	62
<b>5</b>	<b>Checks prior to start up.....</b>	<b>63</b>
5.1	<b>Notes on safety.....</b>	<b>64</b>
5.2	<b>Visual inspections and function tests.....</b>	<b>65</b>
5.3	<b>Checking the engine oil level.....</b>	<b>66</b>
5.4	<b>Checking the fuel level; topping up fuel.....</b>	<b>67</b>
5.5	<b>Checking the hydraulic oil level.....</b>	<b>68</b>
5.6	<b>Checking the coolant level.....</b>	<b>69</b>
5.7	<b>Checking the rubber buffers.....</b>	<b>70</b>
<b>6</b>	<b>Operation.....</b>	<b>71</b>
6.1	<b>Preliminary remarks.....</b>	<b>72</b>
6.1.1	BOSS safety system.....	73
6.1.2	Notes on radio operation.....	74
6.2	<b>Start-up procedure.....</b>	<b>76</b>
6.2.1	Preparing the remote control.....	76
6.2.2	Checking the remote control.....	77
6.2.3	Checking the BOSS safety system.....	81



6.2.4	Starting the engine.....	83
<b>6.3</b>	<b>Travel operation.....</b>	<b>85</b>
6.3.1	Preliminary remarks and safety notes.....	85
6.3.2	Driving the machine.....	86
<b>6.4</b>	<b>Working with vibration.....</b>	<b>88</b>
6.4.1	Preliminary remarks and safety notes.....	88
6.4.2	Vibration in automatic mode.....	88
6.4.3	Manual vibration.....	90
<b>6.5</b>	<b>ECONOMIZER.....</b>	<b>92</b>
<b>6.6</b>	<b>Parking the machine in secured condition.....</b>	<b>93</b>
<b>6.7</b>	<b>Remote control battery (radio operation).....</b>	<b>95</b>
6.7.1	Changing the battery.....	95
6.7.2	Charging the power pack in the machine.....	96
6.7.3	Charging the power pack with the external battery charger.....	97
<b>7</b>	<b>Loading / transporting the machine.....</b>	<b>99</b>
7.1	Preparation for transport.....	100
7.2	Loading the machine.....	101
7.3	Lashing the machine to the transport vehicle.....	102
7.4	Loading by crane.....	103
7.5	After transport.....	104
<b>8</b>	<b>Maintenance.....</b>	<b>105</b>
8.1	Preliminary remarks and safety notes.....	106
8.2	Preparations/concluding work.....	107
8.2.1	Opening the protection hoods.....	107
8.2.2	Engaging/releasing the articulation lock.....	107
8.3	Fuels and lubricants.....	109
8.3.1	Engine oil.....	109
8.3.2	Fuel.....	110
8.3.3	Coolant.....	111
8.3.4	Oil for exciter shaft housing.....	112
8.3.5	Hydraulic oil.....	112
8.4	List of fuels and lubricants.....	113
8.5	Running-in instructions.....	114
8.5.1	General.....	114
8.5.2	After 50 operating hours.....	114
8.5.3	After 250 operating hours.....	114
8.6	Maintenance Table.....	115
8.7	Weekly.....	116
8.7.1	Air filter maintenance.....	116
8.7.2	Checking and cleaning the water separator.....	119
8.8	Every 250 operating hours/annually.....	120
8.8.1	Change engine oil and oil filter cartridge.....	120
8.8.2	Checking, tensioning the V-belt.....	121
8.8.3	Replacing the air filter.....	122
8.8.4	Check the air intake lines.....	123
8.8.5	Changing the oil in the exciter housing.....	124

## Table of contents

8.8.6	Replacing the fuel filter; bleeding the fuel system.....	126
8.8.7	Draining the fuel tank sludge.....	128
8.8.8	Checking radiator hoses and hose clamps.....	128
8.8.9	Servicing the battery; checking the main battery shutoff.....	129
<b>8.9</b>	<b>Every 500 operating hours.....</b>	<b>131</b>
8.9.1	Replacing the V-belt.....	131
<b>8.10</b>	<b>Every 1000 operating hours.....</b>	<b>132</b>
8.10.1	Adjusting the valve clearance.....	132
<b>8.11</b>	<b>Every 2000 operating hours.....</b>	<b>135</b>
8.11.1	Changing the hydraulic oil and filter.....	135
8.11.2	Changing the coolant.....	137
8.11.3	Replacing hoses.....	139
8.11.4	Check the injection valves.....	139
<b>8.12</b>	<b>Every 3000 operating hours.....</b>	<b>140</b>
8.12.1	Checking the fuel injection pump.....	140
<b>8.13</b>	<b>As required.....</b>	<b>141</b>
8.13.1	Checking/adjusting the scrapers.....	141
8.13.2	Cleaning the radiator module.....	141
8.13.3	Cleaning the machine.....	142
8.13.4	Checking the central screw of the drive hub.....	143
8.13.5	Cleaning the drum drive / drums.....	144
8.13.6	Measures prior to extended shut-down period.....	146
<b>9</b>	<b>Setting up / refitting.....</b>	<b>149</b>
<b>9.1</b>	<b>Drum extension.....</b>	<b>150</b>
9.1.1	Preliminary remarks and safety notes.....	150
9.1.2	Removing the drum extension.....	150
9.1.3	Attaching the drum extension.....	151
<b>9.2</b>	<b>Teaching the BOSS safety field system.....</b>	<b>152</b>
<b>10</b>	<b>Troubleshooting.....</b>	<b>155</b>
<b>10.1</b>	<b>Starting the engine with jump leads.....</b>	<b>156</b>
<b>10.2</b>	<b>Switching off the machine manually.....</b>	<b>157</b>
<b>10.3</b>	<b>Decrease in the hydraulic oil level.....</b>	<b>159</b>
<b>10.4</b>	<b>Fuse assignment.....</b>	<b>161</b>
10.4.1	Notes on safety.....	161
10.4.2	Fuse box.....	161
10.4.3	Main fuse.....	162
<b>10.5</b>	<b>Engine faults.....</b>	<b>163</b>
<b>10.6</b>	<b>Remote control faults (cable operation).....</b>	<b>165</b>
<b>10.7</b>	<b>Remote control faults (radio operation).....</b>	<b>167</b>
<b>10.8</b>	<b>Faults in BOSS safety system.....</b>	<b>169</b>
<b>10.9</b>	<b>Trouble shooting ECONOMIZER.....</b>	<b>170</b>
<b>10.10</b>	<b>Fault code display.....</b>	<b>171</b>
<b>10.11</b>	<b>Entering input codes via the display unit.....</b>	<b>172</b>
<b>11</b>	<b>Disposal.....</b>	<b>175</b>
<b>11.1</b>	<b>Final shut-down of machine.....</b>	<b>176</b>

**12 Appendix..... 177**  
**12.1 List of fault codes..... 178**  
**12.2 Input codes for BLM control..... 189**





### 1.1 Foreword

**BOMAG manufactures machines for earth, asphalt and refuse compaction, stabilizers/recyclers as well as planers and pavers.**

**BOMAG's vast experience in connection with state-of-the-art production and testing methods, such as lifetime tests of all important components and highest quality demands guarantee maximum reliability of your machine.**

These operating and maintenance instructions are part of your machine.

They provide necessary information to operate your machine safely and properly.

They also contain information on required operating, maintenance and repair measures.

Carefully read the operating and maintenance instructions before taking your machine into operation.

Please observe the safety regulations strictly and follow all instructions to ensure safe operation.

If you are not yet acquainted with the controls and indicating elements on this machine, you should thoroughly read the corresponding chapter ↪ *Chapter 4 'Indicators and control elements' on page 53.*

The description of the individual operating steps including the notes on safety to be followed can be found in chapter "Operation" ↪ *Chapter 6 'Operation' on page 71.*

Before every start up, carry out all required visual inspections and function tests ↪ *Chapter 5 'Checks prior to start up' on page 63.*

Ensure the compliance with the specified operating, maintenance and repair measures to maintain the functional safety of your machine.

A description of all necessary maintenance work, maintenance intervals as well as information on fuels and lubricants can be found in the chapter "Maintenance" ↪ *Chapter 8 'Maintenance' on page 105.*

Do not service or repair your machine by yourself to avoid harming persons or damaging material or environment.

The machine must only be serviced and repaired by qualified and authorized personnel.

Contact our Customer Service to carry out the required maintenance work or necessary repairs.

In case of operating errors, inadequate maintenance or the use of unapproved fuels and lubricants all warranty claims will become null and void.

For your own personal safety you should only use original parts from BOMAG.

For your machine we offer service kits to make maintenance easier.

In the course of technical development we reserve the right for technical modifications without prior notification.

These operating and maintenance instructions are also available in other languages.

Apart from that, you can also order the spare parts catalogue against the serial number of your machine.

The above notes do not constitute an extension of the warranty and liability conditions specified in the general sales and delivery conditions of BOMAG GmbH.

We wish you successful work with your BOMAG machine.

**1.2 Machine type plate and engine type plate**

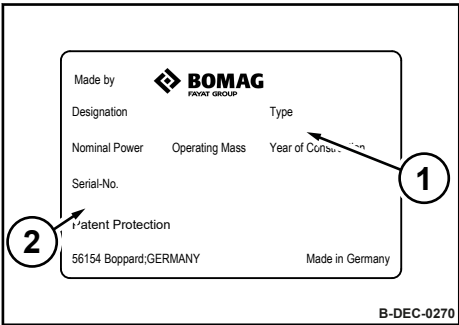

*Fig. 1: Machine type plate (example)*

<b>Please enter here:</b>	
Machine type (1):	
Serial number (2):	

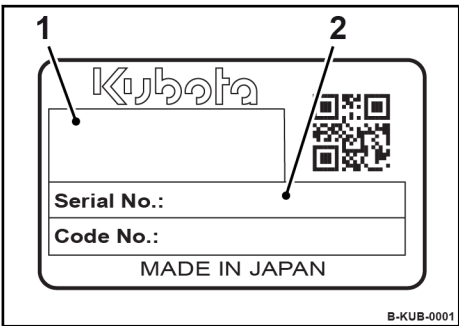

*Fig. 2: Engine type plate (example)*

<b>Please enter here:</b>	
Engine type (Fig. 1)	
Engine number (2):	





## Technical data

### Dimensions

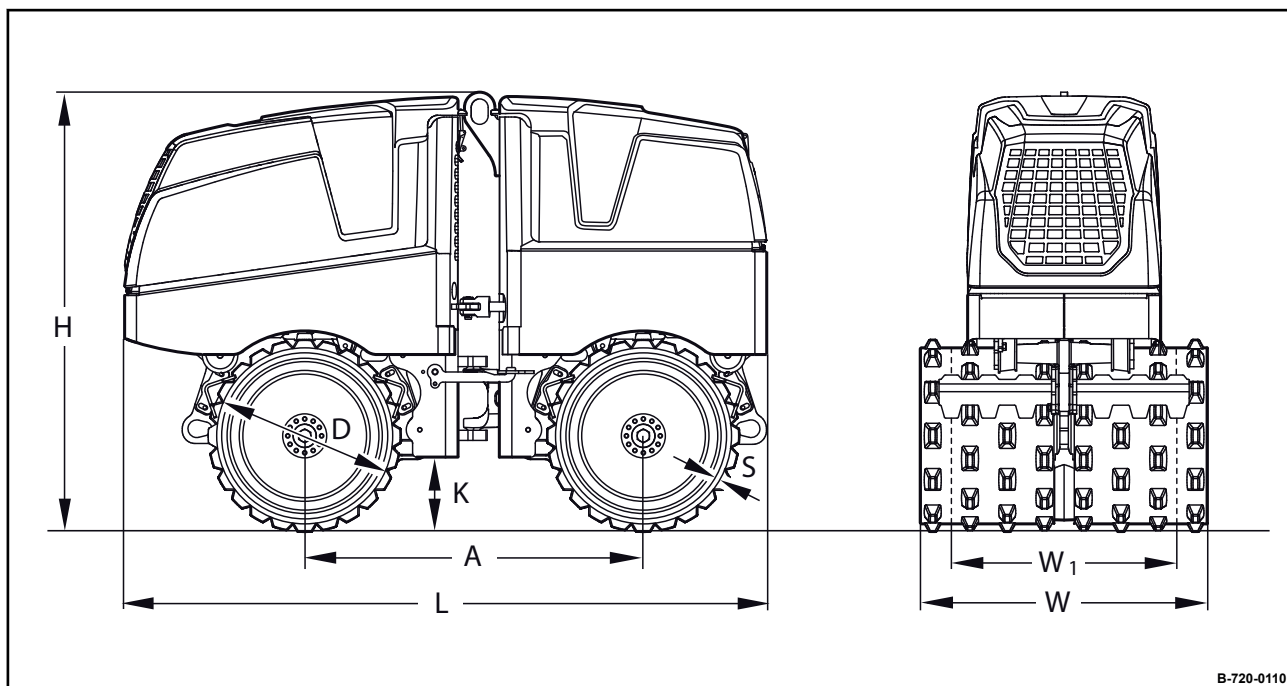

B-720-0110

Fig. 3

A	D	H	K	L	S	W	W <sub>1</sub>
1000	520	1275	197	1897	16	850	610
(39)	(20.5)	(50)	(7.8)	(75)	(0.6)	(33.5)	(24)

Dimensions in millimetres  
(Dimensions in inch)

Weights			
Operating weight (CECE)		1595	kg
		(3516)	(lbs)
Basic weight		1585	kg
		(3494)	(lbs)
Mean axle load (CECE)		798	kg
		(1759)	(lbs)
Drum extension (610/850 mm)		+ 48	kg
		(+ 106)	(lbs)

## Technical data

<b>Travel characteristics</b>		
Travel speed (1) forward/reverse	1.2 (0.7)	km/h (mph)
Travel speed (2) forward/reverse	2.8 (1.7)	km/h (mph)
Max. gradability without/with vibration (soil dependent)	55/45	%

<b>Drive</b>		
Engine manufacturer	Kubota	
Type	D1005	
Cooling	Water	
Number of cylinders	3	
Rated power ISO 3046	14.5	kW
Rated speed	2600	min <sup>-1</sup>
Drive system	hydrostatic	
Driven drum	4	

<b>Brakes</b>		
Service brake	hydrostatic	
Parking brake	hydro-mechanical	

<b>Steering</b>		
Type of steering	Articulated joint	
Steering operation	hydrostatic	

<b>Exciter system</b>		
Vibrating drum	front + rear	
Drive system	hydraulic	
Frequency	42 (2520)	Hz (vpm)
Amplitude 1/2	1.12/0.56 (0.044/0.022)	mm (in)
Centrifugal force 1/2	72/36 (16186/8093)	kN (lbf)

## Technical data

Filling capacities		
Fuel (diesel)	24 (6)	l (gal us)

Safety field system		
Size of the safety field in front of/behind the machine	1.2 (1.3)	m (yd)

Safety field control		
Voltage	8 to 30	V
Current consumption at 12 V	1.5	A
IP rating	IP 55	
Safety field frequency	125	kHz

Transponder in remote control		
Voltage (cable operation)	9 to 30	V
Voltage (battery operation)	3.6	V
Transmitting frequency range	868/916	MHz

Safety field antenna		
IP rating	IP 55	

Transmitter		
Frequency band	F-band	
Transmitting frequency range	868/916	MHz
Number of channels	1	
Current consumption	approx. 10	mA

Receiver		
Receiver frequency range	868/916	MHz

## Technical data – Noise data

Transmitter power pack		
Voltage	3.6	V
Capacity	1.2	Ah

Charger (optional equipment)		
Operating voltage	110/230	V (AC)
	12-24	V (DC)

### 2.1 Noise data

The following noise and vibration data were determined in accordance with the following guidelines under equipment specific conditions and by using harmonized standards:

- EU Machine Directive edition 2006/42/EU
- Noise Emission Directive 2000/14/EU, Noise Protection Directive 2003/10/EU

During operation these values may vary because of the prevailing operating conditions.

#### Sound pressure level at the operator's stand

$L_{pA} = 84$  dB(A), determined acc. to ISO 11201 and EN 500.



#### **WARNING!**

**Loss of hearing caused by too high noise burdens!**

- Wear your personal protective equipment (ear protection).

#### Guaranteed sound power level

$L_{WA} = 109$  dB(A), determined acc. to ISO 3744 and EN 500





### 3.1 Basic prerequisites

#### 3.1.1 General

This machine has been built in compliance with the latest technical standard and complies with the applicable regulations and technical rules.

However, dangers for persons and property may arise from this machine, if:

- it is used for purposes other than the ones it is intended for,
- it is operated by untrained personnel,
- it is changed or converted in an unprofessional way,
- the safety instructions are not observed.

Each person involved in the operation, maintenance and repair of the machine must therefore read and comply with these safety regulations. If necessary, the operating company must obtain the relevant signatures as confirmation.

Furthermore, the following obviously also applies:

- applicable accident prevention instructions,
- generally accepted safety and road traffic regulations,
- country/state specific safety regulations.

It is the duty of the operator to be acquainted with the safety regulations and to apply these accordingly. This also applies for local regulations and regulations concerning different types of handling activities. Should the recommendations in these instructions be different from the regulations valid in your country, you must comply with the safety regulations valid in your country.

#### 3.1.2 Explanation of signal words used:



##### **DANGER!**

##### **Danger to life if failing to comply!**

Sections marked accordingly indicate an extremely dangerous situation that could lead to fatal or severe injuries, if this warning is disregarded.



##### **WARNING!**

##### **Danger to life or danger of severe injuries if failing to comply!**

Sections marked accordingly indicate a dangerous situation that could lead to fatal or severe injuries, if this warning is disregarded.



## Concerning your safety – Basic prerequisites



### CAUTION!

#### Danger of injury if failing to comply!

Sections marked accordingly indicate a dangerous situation that could lead to fatal or severe injuries, if this warning is disregarded.



### NOTICE!

#### Danger of material damage if failing to comply!

Sections marked accordingly indicate possible dangers for machines or components.



*Sections marked accordingly indicate technical information or notes on using the machine or its components.*



### ENVIRONMENT!

#### Environmental damage if failing to comply!





Paragraphs marked accordingly indicate practices for safe and environment-friendly disposal of fuels and lubricants as well as replacement parts.

### 3.1.3 Personal protective equipment

Depending on the work to be carried out, personal protective equipment is required (to be provided by the operating company):

	Working clothes	Tight fitting working clothes with low tear resistance, tight sleeves and without any projecting parts protect against being caught by moving components.
	Safety shoes	To protect against heavy falling parts and slipping on slippery ground.
	Protective gloves	To protect the hands against excoriation, punctures or deep injuries, against irritating and caustic substances as well as against burns.

## Concerning your safety – Basic prerequisites

	Safety goggles	To protect the eyes against airborne particles and squirting fluids.
	Face protection	To protect the face against airborne particles and squirting fluids.
	Hard hat	To protect the head against falling parts and to protect against injuries.
	Hearing protection	To protect hearing against excessive noise.
	Respiratory protection	To protect respiratory tracts against substances or particles.

### 3.1.4 Intended use

This machine is only to be used for:

- Compaction of cohesive soils in trench construction
- Construction backfills
- Earthwork in sewer and pipeline construction
- Earthwork in railway and dam construction
- Earthwork in landfill construction
- Substructure and foundation works

The operator's position is behind the machine.

When operating the machine from the opposite side, there is a discrepancy between the actuation of the control devices for the travel movements and the respective control movement of the machine.

The remote control must be carried in front of the body, as intended.

### 3.1.5 Improper use

Dangers may arise with the machine if it is used other than for its intended purpose.

Any hazard caused by improper use is the sole responsibility of the operating company or driver/operator, the manufacturer cannot be held liable.

Examples of improper use are:

- Work with vibration on hard concrete, cured bitumen layers or extremely frozen ground
- Driving on liquid/soft concrete
- Driving on non-load-bearing subsoil or inadequate contact areas (danger of tilting)
- Using the machine for towing
- Operating the machine without visual contact

The transport of persons is prohibited.

Starting and operating the machine in explosive environments and in underground mining is prohibited.

### 3.1.6 Estimated service life of the machine

If the following general conditions are met, the estimated service life of the machine is usually in the range of several thousand operating hours:

- Regular safety inspections by an expert / qualified person
- Performance of the prescribed maintenance work within the specified time
- Immediate performance of necessary repair work
- Exclusive use of original spare parts

### 3.2 Definition of responsible persons

#### 3.2.1 Operating company

The operating company is the natural or juridical person who uses the machine or in who's name the machine is used.

The operating company must make sure that the machine is only used for the purpose it is intended for and in strict compliance with the safety regulations mentioned in these operating and maintenance instructions.

The operating company must determine and assess the danger in its company. It must then take appropriate action to ensure health and safety at work for its employees and point out any remaining dangers.

The operating company must determine whether there are special operational hazards such as a toxic atmosphere or limiting soil conditions. Such conditions require special, additional measures to remove or reduce the hazard.

The operating company must make sure that all users read and understand the information concerning safety.

The operating company is responsible for the planning and professional execution of regular safety inspections.

#### 3.2.2 Expert / qualified person

An expert / qualified person is a person who, based on his/her professional education and experience, has profound knowledge in the field of construction equipment and the machine in question in particular.

This person is acquainted with the applicable governmental industrial safety regulations, accident prevention instructions, guidelines and generally acknowledged technical rules and regulations (standards, directives, technical rules of other member states of the European Union or other contractual states concerning the agreement about the European Economic Area) in as far as is necessary to be able to judge the safe condition of this machine.

#### 3.2.3 Driver / operator

This machine must only be operated by trained, instructed persons entrusted by the operating company aged 18 or more.

Observe your local laws and regulations.

Rights, obligations and rules of conduct for driver or operator:

The driver or operator must:

- be instructed about his rights and obligations,
- wear protective equipment as appropriate for the application,
- have read and understood the operating instructions,

## Concerning your safety – Definition of responsible persons

- have made himself familiar with the operation of the machine,
- be physically and psychologically able to drive and operate the machine.

Persons under the influence of alcohol, medication or drugs are not allowed to operate, service or repair the machine.

Maintenance and repair work requires specific knowledge and must therefore only be performed by trained specialists.

### **3.3 Basic safety regulations for safe operation**

#### **3.3.1 Remaining dangers, remaining risks**

Despite careful work and compliance with standards and regulations it cannot be ruled out that further dangers may arise when working with and handling the machine.

Both the machine as well as all other system components comply with the currently valid safety regulations. Nevertheless, remaining risks cannot be ruled out completely, even when using the machine for the purpose it is intended for and following all information given in the operating instructions.

A remaining risk can also not be excluded beyond the actual danger zone of the machine. Persons remaining in this area must pay particular attention to the machine, so that they can react immediately in case of a possible malfunction, an incident or failure etc.

All persons remaining in the area of the machine must be informed about the dangers that arise from the operation of the machine.

#### **3.3.2 Regular safety inspections**

Have the machine inspected by an expert / qualified person as required for the conditions the machine is working under, but at least once every year.

#### **3.3.3 Modifications and alterations to the machine**

Unauthorized changes to the machine are prohibited for safety reasons.

Original parts and accessories have been specially designed for this machine.

We wish to make explicitly clear that we have not tested or approved any parts or accessories not supplied by us.

The installation and/or use of such products may have an adverse effect on the active and/or passive safety.

#### **3.3.4 Damage, defects, misuse of safety devices**

Machines which are not safe to operate or in traffic must be immediately taken out of service and shall not be used, until these deficiencies have been properly rectified.

Safety installations and switches must neither be removed nor must they be made ineffective.

### 3.4 Handling fuels and lubricants

#### 3.4.1 Preliminary remarks

The operating company must ensure that all professional users have read and follow the corresponding safety data sheets for the individual fuels and lubricants.

Safety data sheets provide valuable information about the following characteristics:

- name of substance
- possible dangers
- composition / information on constituents
- first-aid measures
- fire fighting measures
- measures in case of accidental release
- handling and storage
- limitation and monitoring of exposure / personal protective equipment
- physical and chemical properties
- stability and reactivity
- toxicological data
- environmental data
- notes on waste disposal
- information on transport
- legislation
- other data

### 3.4.2 Safety regulations and environmental protection regulations for handling diesel fuel

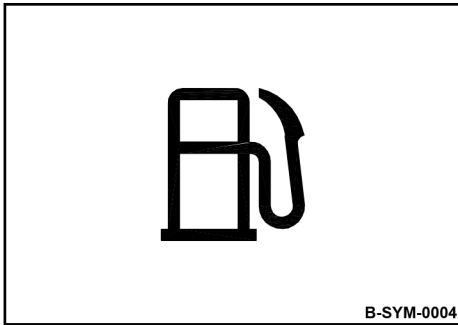

Fig. 4



#### **WARNING!**

##### **Danger of burning by ignited diesel fuel!**

- Do not allow diesel fuel to come into contact with hot components.
- Smoking and open fire is prohibited!
- Wear your personal protective equipment (protective gloves, protective clothing).



#### **CAUTION!**

##### **Health hazard caused by contact with diesel fuel!**

- Wear your personal protective equipment (protective gloves, protective clothing).
- Do not inhale any fuel fumes.
- Avoid contact.



#### **CAUTION!**

##### **Danger of slipping on spilled diesel fuel!**

- Immediately bind spilled diesel fuel with an oil-binding agent.



#### **ENVIRONMENT!**

##### **Diesel fuel is an environmentally hazardous substance!**

- Always keep diesel fuel in proper containers.
- Immediately bind spilled diesel fuel with an oil-binding agent and dispose of properly.
- Dispose of diesel fuel and fuel filters according to regulations.



### 3.4.3 Safety regulations and environmental protection regulations for handling oil

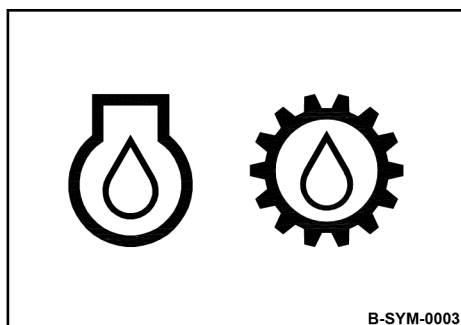

Fig. 5



#### **WARNING!**

##### **Danger of burning by ignited oil!**

- Do not allow oil to come into contact with hot components.
- Smoking and open fire is prohibited!
- Wear your personal protective equipment (protective gloves, protective clothing).



#### **CAUTION!**

##### **Health hazard caused by contact with oil!**

- Wear your personal protective equipment (protective gloves, protective clothing).
- Do not inhale any oil vapours.
- Avoid contact.



#### **CAUTION!**

##### **Danger of slipping on spilled oil!**

- Immediately bind spilled oil with an oil-binding agent.



#### **ENVIRONMENT!**

##### **Oil is an environmentally hazardous substance!**

- Always keep oil in proper containers.
- Immediately bind spilled oil with an oil-binding agent.
- Dispose of oil and oil filter according to regulations.

### 3.4.4 Safety regulations and environmental protection regulations for handling hydraulic oil

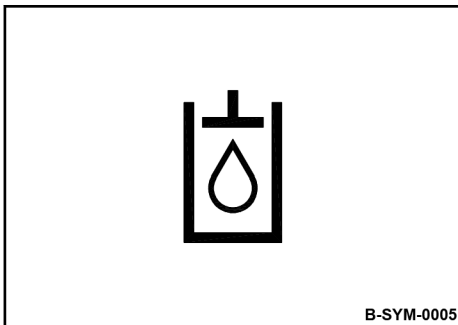

Fig. 6



#### **WARNING!**

##### **Danger of injury caused by escaping pressure fluid!**

- Always depressurize the hydraulic system before starting work in the hydraulic system.
- Wear your personal protective equipment (protective gloves, protective clothing, goggles).



*Should pressure fluid penetrate the skin, immediate medical help is required.*



#### **WARNING!**

##### **Danger of burning by ignited hydraulic oil!**

- Do not allow hydraulic oil to come into contact with hot components.
- Smoking and open fire is prohibited!
- Wear your personal protective equipment (protective gloves, protective clothing).



#### **CAUTION!**

##### **Health hazard caused by contact with hydraulic oil!**

- Wear your personal protective equipment (protective gloves, protective clothing).
- Do not inhale any oil vapours.
- Avoid contact.



#### **CAUTION!**

##### **Danger of slipping on spilled oil!**

- Immediately bind spilled oil with an oil-binding agent.



#### **ENVIRONMENT!**

##### **Oil is an environmentally hazardous substance!**

- Always keep oil in proper containers.
- Immediately bind spilled oil with an oil-binding agent.
- Dispose of oil and oil filter according to regulations.

### 3.4.5 Safety regulations and environmental protection regulations for handling coolants

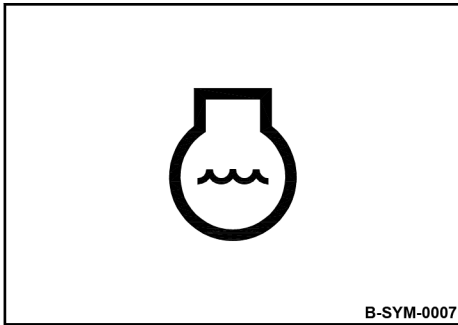

Fig. 7



#### **WARNING!**

##### **Danger of scalding by hot fluid!**

- Open the compensation tank only when the engine is cold.
- Wear your personal protective equipment (protective gloves, protective clothing, goggles).



#### **CAUTION!**

##### **Health hazard caused by contact with coolant and coolant additives!**

- Wear your personal protective equipment (protective gloves, protective clothing).
- Do not inhale any fumes.
- Avoid contact.



#### **CAUTION!**

##### **Danger of slipping on spilled coolant!**

- Immediately bind spilled coolant with an oil-binding agent.



#### **ENVIRONMENT!**

##### **Coolant is an environmentally hazardous substance!**

- Always keep coolant and coolant additives in proper containers.
- Immediately bind spilled coolant with an oil-binding agent and dispose of it according to regulations.
- Dispose of coolant according to regulations.

### 3.4.6 Safety regulations and environmental protection regulations for handling battery acid

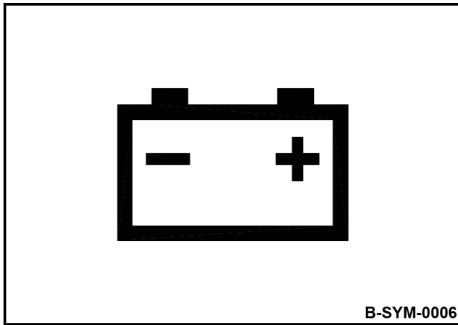

Fig. 8:



#### WARNING!

##### Danger of cauterization with acid!

- Wear your personal protective equipment (protective gloves, protective clothing, goggles).
- Do not allow clothes, skin or eyes to come into contact with acid.
- Rinse off spilled battery acid immediately with lots of water.



*Rinse acid off clothes, skin or eyes immediately with lots of clean water.*

*Immediately call for medical advice in case of cauterization.*



#### WARNING!

##### Danger of injury caused by exploding gas mixture!

- Remove the plugs before starting to recharge the battery.
- Ensure adequate ventilation.
- Smoking and open fire is prohibited!
- Do not lay any tools or other metal objects on the battery.
- Do not wear jewellery (watch, bracelets, etc.) when working on the battery.
- Wear your personal protective equipment (protective gloves, protective clothing, goggles).



#### ENVIRONMENT!

##### Battery acid is an environmentally hazardous substance!

- Dispose of battery and battery acid according to regulations.

### 3.5 Loading/transporting the machine

Use only stable loading ramps of sufficient load bearing capacity.

Loading ramps and transport vehicle must be free of grease, oil, snow and ice.

The ramp inclination must be less than the gradeability of the machine.

Make sure that persons are not endangered by the machine tipping or sliding.

Secure the machine with the articulation lock after driving it onto the transport vehicle or prior to lifting.

Do not use lifting points that are damaged or impaired in any way.

Always use appropriate lifting tackle at the lifting points.

Use lifting tackle only in the specified loading direction.

Lifting tackle must not be damaged by machine parts.

Secure the machine on the transport vehicle against rolling, slipping and turning over.

Loads may only be attached and hoisted by an expert/qualified person.

Only use lifting and lashing tackle with sufficient load bearing capacity for the weight to be loaded.

Fasten the lifting gear only at the specified lifting points.

Danger to the life of persons if they step or stand under a suspended load.

When lifting the machine, make sure the load does not move in an uncontrolled way. If necessary, hold the load steady with guide ropes.

After the transport loosen the articulation lock again, as otherwise the machine would not be steerable.

### 3.6 Start-up procedure

#### 3.6.1 Prior to start-up

Only use machines which have been serviced at regular intervals.

Become acquainted with the equipment, the indicators and control elements, the working principle of the machine and the working area.

Use your personal protective equipment (hard hat, safety boots, if necessary also goggles and ear protection).

Do not take any loose objects with you or fasten them to the machine.

Before start-up, check whether:

- persons or obstructions are beside or under the machine;
- the machine is free of oily and combustible materials;
- all protective devices are in place;
- all maintenance flaps and doors are closed and locked.

Before start-up, carry out all required visual inspections and function tests.

If the tests reveal damage or other defects, the machine must not be operated until these have been rectified.

Do not operate the machine with defective indicators and control elements.

#### 3.6.2 Starting the engine

Before starting and moving the machine, make sure that there is nobody in the danger zone.

The operator's position is behind the machine.

The machine must only be started and operated from the operator's position.

The remote control must be carried in front of the body, as intended.

To start, set all control levers to "neutral position".

Do not use any starting aids like start pilot or ether.

The machine must not be operated with damaged, missing or non-functional safety devices.

After starting, check all display instruments.

Do not inhale exhaust fumes, because they contain toxic substances, which could cause damage to health, unconsciousness or even death.

For operation in closed or partly closed rooms ensure adequate ventilation.

### 3.6.3 Starting the engine with jump leads

Connect positive with positive and negative with negative (ground cable) – always connect the ground strap last and disconnect it first! A wrong connection will cause severe damage in the electric system.

Do not start the engine by shorting the electric terminals on the starter motor, because the machine may start to drive immediately.

### 3.7 Operation with radio remote control

The machine must only be operated within the operator's field of vision.

In case of radio interferences, watch the fault code display and switch to cable remote control, if necessary.

Shut down defective radio remote controls immediately. Actuate the emergency stop. Disconnect the connecting cable on the receiver from the machine socket.

The radio remote control must only be repaired by the manufacturer or specialists authorised by the manufacturer.

The radio remote control must never be left unattended.

If several machines are in operation at the same time, the system numbers on the radio remote control and receiver must be compared before start-up to ensure another machine within range is not accidentally started up.



### 3.8 Driving the machine; working operation

#### 3.8.1 Persons in the danger zone

Before taking up work, also after breaks, you should always convince yourself that the danger zone is free of persons or obstructions, especially when driving in reverse.

Give warning signals, if necessary. Stop work immediately if persons remain in the danger zone, despite the warning.

#### 3.8.2 Driving the machine

Only drive on load-bearing surfaces.

In case of unusual noises and development of smoke perform troubleshooting to determine the cause and have the fault corrected.

Match the speed to the working conditions.

Always keep a safe distance to excavation pit borders, embankments and edges.

Refrain from any work that could adversely affect the stability of the machine.

#### 3.8.3 Driving up and down slopes

Do not drive on gradients or slopes exceeding the maximum gradeability of the machine ↪ *Chapter 2 'Technical data' on page 13.*

Drive extremely carefully on gradients and always directly up or down the slope.

Soil conditions and weather influences impair the gradeability of the machine.

Wet and loose soil considerably reduces traction of the machine on inclinations and slopes. Increased danger of accident!

#### 3.8.4 Cross slope

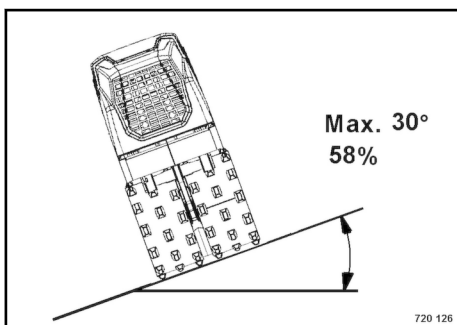

Fig. 9: Maximum cross slope

The tipping angle was measured on level, hard ground with the machine stopped and without steering.

The specified angle must not be exceeded.

With loose soil, acceleration/deceleration, running vibration, steering or attached accessories the tipping angle may be considerably lower.

Driving across slopes should therefore be strictly avoided, because of the high risk of tipping over and the related risk of severe or even fatal accidents.

### 3.8.5 Working with vibration

When compacting with vibration you must always check the effect of the vibration on nearby buildings and underground supply lines (gas, water, sewage, electric power). If necessary stop compacting with vibration.

Do not activate the vibration on hard (frozen, concrete) ground. Components may get damaged.

### 3.8.6 Parking the machine

Park the machine on horizontal, level, firm ground.

Before leaving the machine:

- shift all control levers to “neutral position”, “off” or “0”;
- switch off the engine and remove the ignition key;
- remove the main battery switch;
- secure the machine against unauthorised use.

Mark machines, which could be in the way, with a clearly visible sign.

When parking on ascents or descents use appropriate means to secure the machine against rolling.

### 3.9 Refuelling

Do not inhale any fuel fumes.

Refuel only with the engine shut down.

Do not refuel in closed rooms.

No open fire, do not smoke.

Static charges may be generated in the fuel as it passes through the filling system. The discharge of these charges in the presence of combustible vapours can cause fire or an explosion.

Ultra-low sulphur diesel fuel poses a higher risk of combustion caused by the static charging than diesel fuel with a higher sulphur content.

You should therefore always make sure that the filling system is properly grounded and that there is equipotential bonding to the machine. If necessary use a connecting cable between filling system and vehicle ground.

Monitor the entire refuelling process.

Do not spill any fuel. Collect leaking fuel, do not let it seep into the ground.

Wipe off spilled fuel. Keep dirt and water away from the fuel.

A leaking fuel tank can cause an explosion. Ensure tight fit of the fuel tank cover, if necessary replace immediately.

### 3.10 Emergency procedures

#### 3.10.1 Actuating the emergency stop switch

In events of emergency and in case of danger actuate the emergency stop switch immediately.

The machine is braked immediately; the engine is shut down.

Restart the machine only after the danger that caused the actuation of the emergency stop switch has been eliminated.

#### 3.10.2 Disconnecting the battery

In events of emergency, e.g. in case of a cable fire, disconnect the battery from the vehicle network.

Pull out the main battery switch or lift off the battery pole to do so.

#### 3.10.3 Recovering the machine

The machine can be recovered by lifting it out of the danger zone.

Loads may only be attached and hoisted by an expert/qualified person.

Before lifting the machine, lock it with the articulation lock.

Do not use lifting points that are damaged or impaired in any way.

Use only lifting and lashing tackle with sufficient load bearing capacity.

Fasten the lifting gear only at the specified lifting points.

Always use appropriate lifting and lashing tackle at the lifting points.

Use lifting tackle only in the specified loading direction.

Lifting tackle must not be damaged by machine parts.

Danger to the life of persons if they step or stand under a suspended load.

When lifting the machine, make sure the load does not move in an uncontrolled way. If necessary, hold the load steady with guide ropes.

### 3.11 Maintenance work

#### 3.11.1 Preliminary remarks

Always carry out the prescribed maintenance work and maintenance measures on time in order to maintain the safety, operational readiness and long service life of the machine.

The machine must only be serviced by qualified personnel authorised by the operating company.

#### 3.11.2 Working on hydraulic lines

Relieve hydraulic pressures before working on hydraulic lines. Hydraulic oil escaping under pressure can penetrate the skin and cause severe injury. Immediately call for medical assistance if injured by hydraulic oil.

Do not step in front of or behind the machine when performing adjustment work in the hydraulic system.

Do not change the setting of pressure relief valves.

Drain the hydraulic oil at operating temperature – danger of scalding!

Any hydraulic oil must be collected and disposed of in an environmentally friendly way.

Always collect and dispose of hydraulic oils separately.

Do not start the engine after draining off the hydraulic oil. Once all work is completed (with the system still depressurized!) check all connections and fittings for leaks.

Hydraulic hoses must be visually inspected at regular intervals.

Do not mix up hoses by mistake.

Only genuine replacement hydraulic hoses ensure that the correct hose type (pressure range) is used at the right location.

#### 3.11.3 Working on the engine

Do not work on the fuel system while the engine is running - danger to life due to high pressures!

Wait until the engine has stopped, then wait approx. another 15 minutes.

Keep out of the danger zone during the initial test run.

In case of leaks return to the workshop immediately.

Drain the engine oil at operating temperature – danger of scalding!

Wipe off spilled oil, collect leaking oil and dispose of it in an environmentally friendly way.

Store used filters and other oil contaminated materials in a separate, specially marked container and dispose of them in an environmentally friendly way.

The settings for idle speed and highest speed must not be changed, since this would affect the exhaust gas values and cause damage to engine and power train.

Engine and exhaust system work at high temperatures. Keep combustible materials away and do not touch any hot surfaces.

Check and change coolant only when the engine is cold. Collect coolant and dispose of it in an environmentally friendly way.

### 3.11.4 Maintenance work on electric components and battery

Before starting to work on electric parts of the machine disconnect the battery and cover it with insulating material.

Do not use fuses with higher ampere ratings and do not bridge fuses.

When working on the battery, smoking or open fire is prohibited!

Do not lay any tools or other metal objects on the battery.

Do not wear jewellery (watch, bracelets, etc.) when working on the battery.

The connection cables of the battery must not touch or rub against machine parts.

### 3.11.5 Cleaning work

Do not perform cleaning work while the motor is running.

Allow the engine to cool down before starting cleaning work on engine and exhaust system.

Never use gasoline or other easily inflammable substances for cleaning.

When cleaning with a high pressure cleaner, do not subject electrical parts and insulation material to the direct jet of water, or cover them beforehand.

Do not guide the water jet into the exhaust pipe and into the air filter.

### 3.11.6 Measures for longer shut-down periods

If the machine is taken out of operation for a longer period of time, various conditions must be met and maintenance work must be carried out both before and after shut-down ↪ *Chapter 8.13.6 'Measures prior to extended shut-down period' on page 146.*

It is not necessary to define a maximum storage period if these measures have been performed.

**3.11.7 After maintenance work**

Reassemble all guards and protective devices.

Close all maintenance flaps and maintenance doors again.

### 3.12 Repair

Identify a defective machine with a warning sign.

Only operate the machine after it has been repaired.

Repairs must only be performed by an expert/qualified person.

When replacing safety relevant components, only original spare parts must be used.



### 3.13 Signage

Keep stickers and signage in good and legible condition and comply with their meaning.

Replace damaged and illegible stickers or signage immediately.

# Concerning your safety – Signage

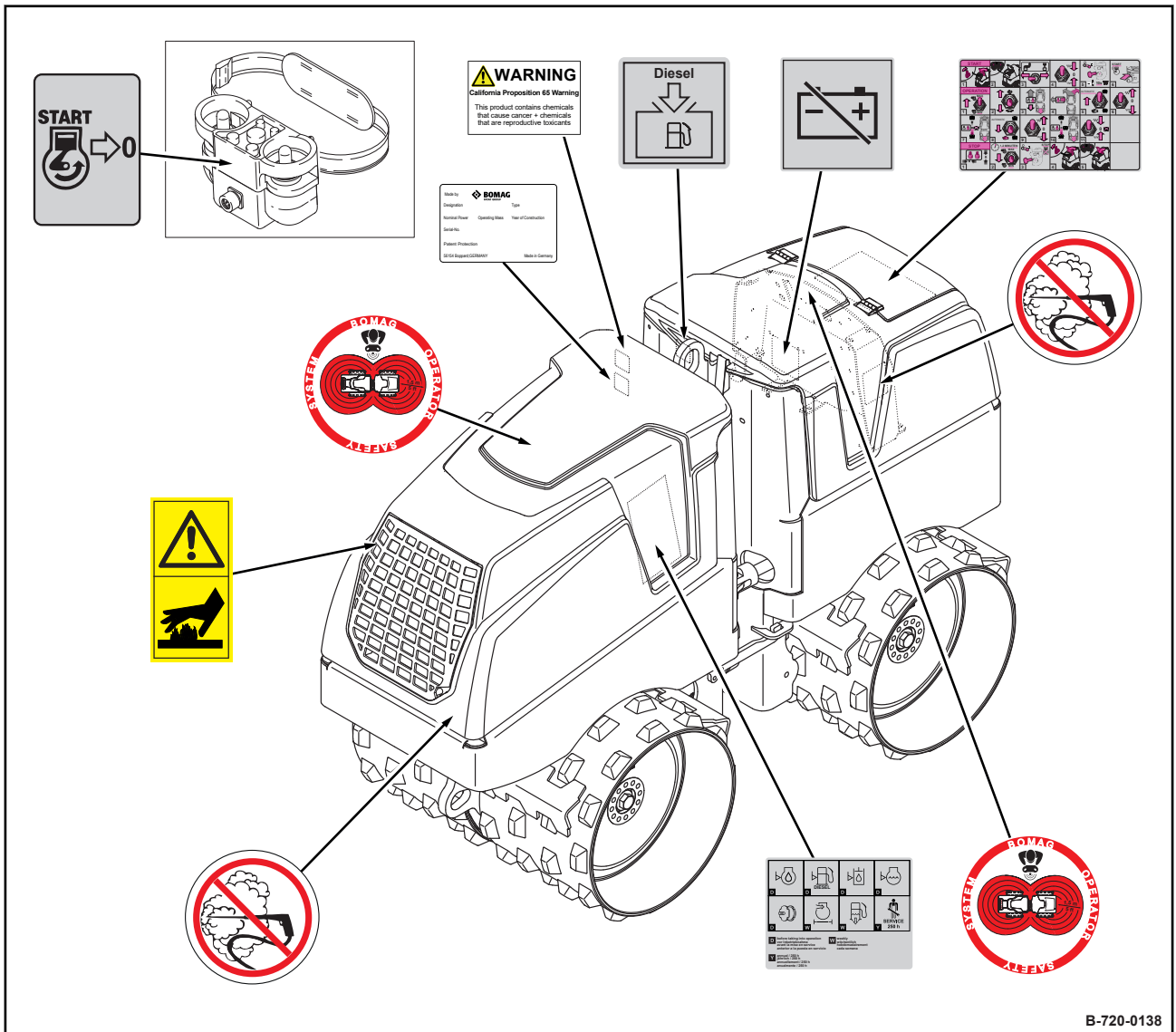

Fig. 10

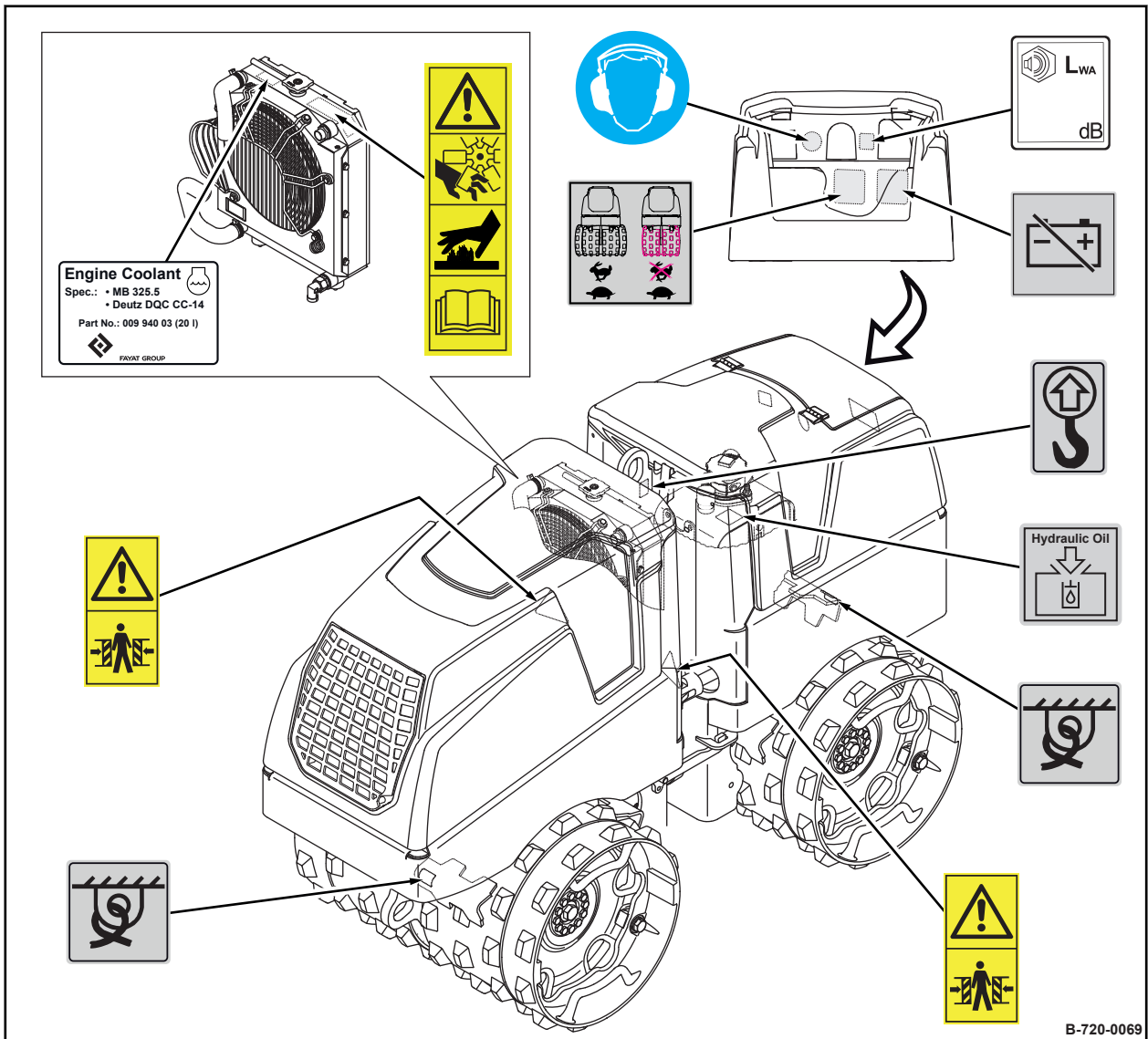

Fig. 11



Warning sticker - Danger of crushing

Fig. 12

## Concerning your safety – Signage



Warning sticker - Hot surface

Fig. 13

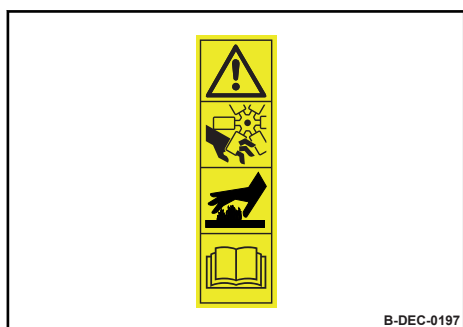

Warning sticker - Danger of being pulled in by cooling fan, and hot surface Follow operating instructions

Fig. 14



Warning sticker – California Proposition 65

Fig. 15



Prohibition sticker - High pressure cleaning

Fig. 16



Instruction sticker - Wear ear defenders

Fig. 17

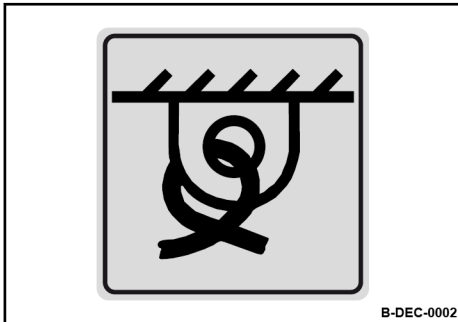

Information sticker - Lashing point

Fig. 18

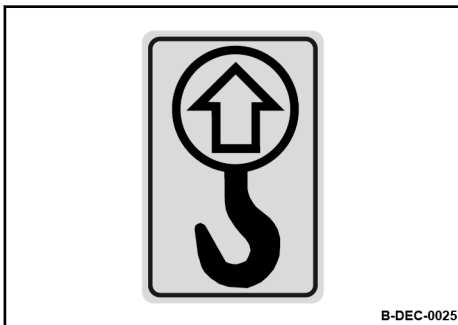

Information sticker - Lifting point

Fig. 19

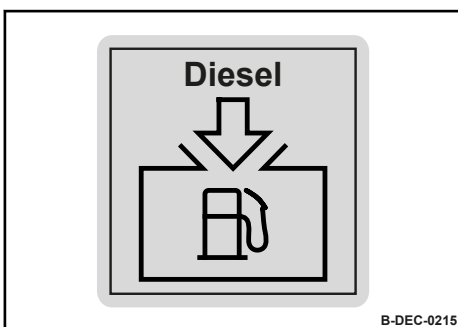

Information sticker - Filler opening for diesel

Fig. 20

## Concerning your safety – Signage

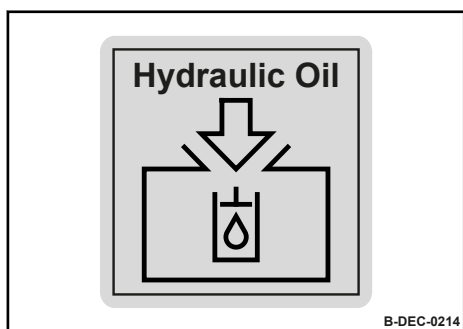

Information sticker - Filler opening for hydraulic oil

Fig. 21

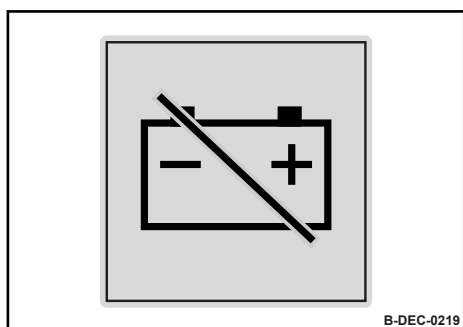

Information sticker - Disconnecting the battery

Fig. 22

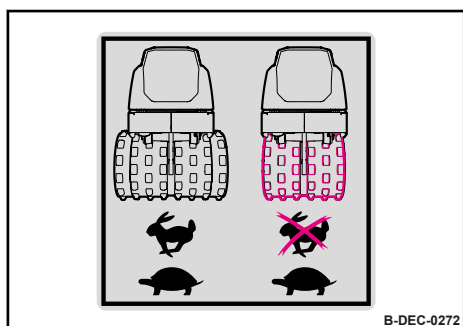

Information sticker - Low travel speed range

Fig. 23

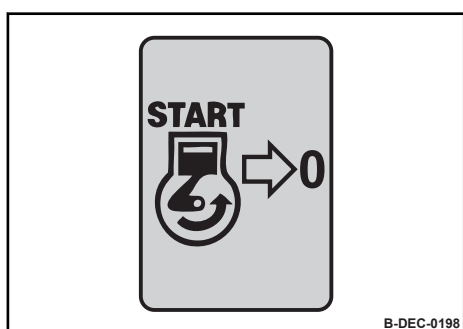

Information sticker - Engine start

Fig. 24

## Concerning your safety – Signage

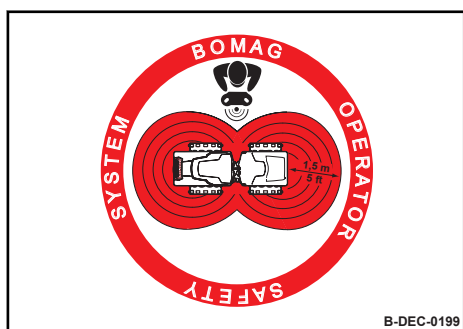

Information sticker - BOSS safety field

Fig. 25

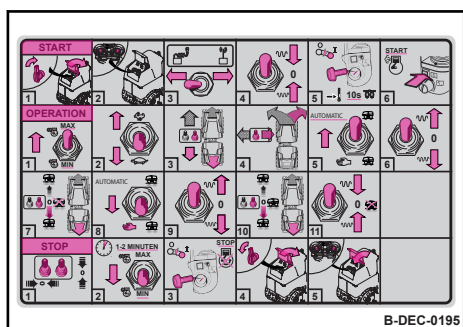

Brief operating guide

Fig. 26

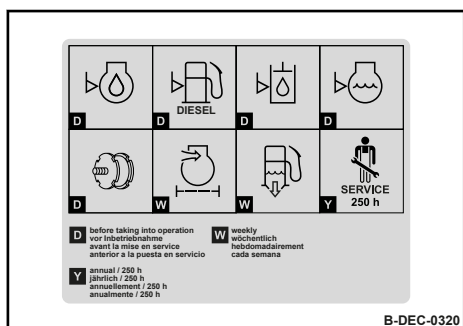

Maintenance sticker

Fig. 27

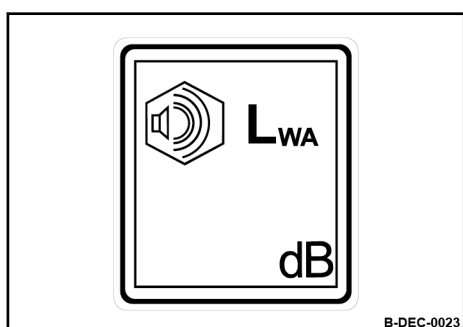

Information sticker - Guaranteed sound capacity level

Fig. 28

# Concerning your safety – Signage

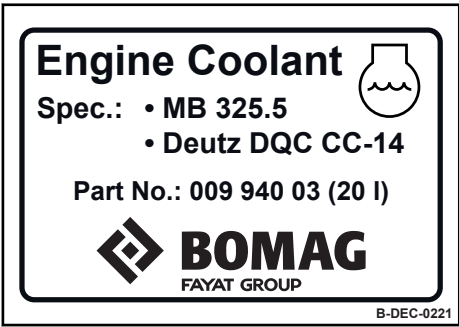

Information sticker - Coolant

Fig. 29

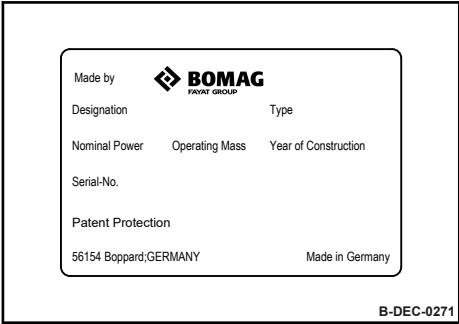

Machine type plate (example)

Fig. 30





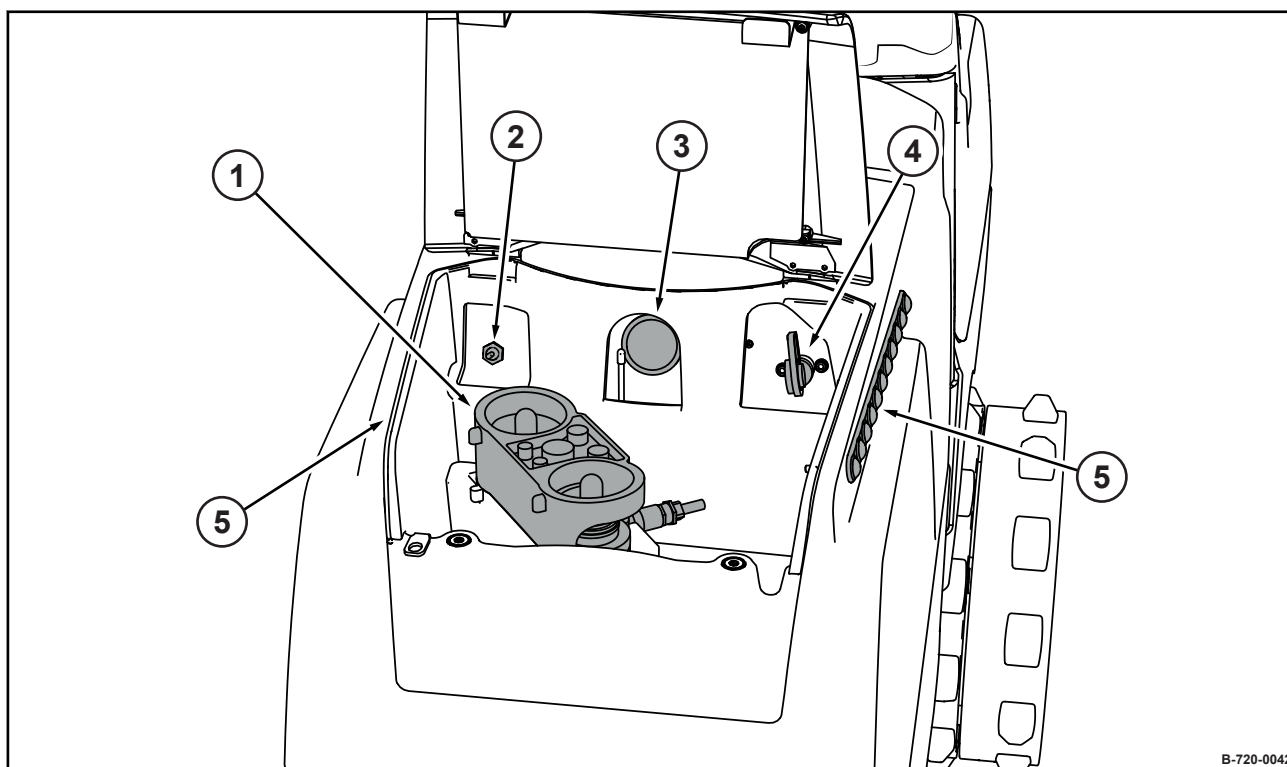

B-720-0042

Fig. 31

- 1 Remote control
- 2 Operating mode toggle switch
- 3 Display module
- 4 Main battery switch
- 5 ECONOMIZER display (optional equipment)

### 4.1 ECONOMIZER display

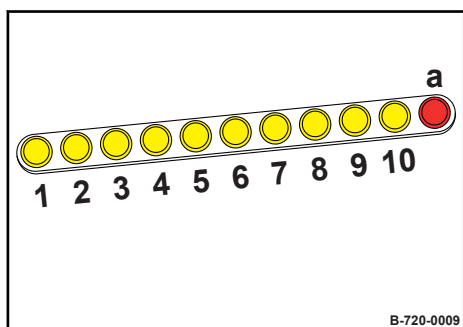

B-720-0009

Fig. 32

The ECONOMIZER indicates the compaction status of the subsoil.



Description of display options ↗ Chapter 6.5 'ECONOMIZER' on page 92.



Optional equipment

## 4.2 Operating mode toggle switch

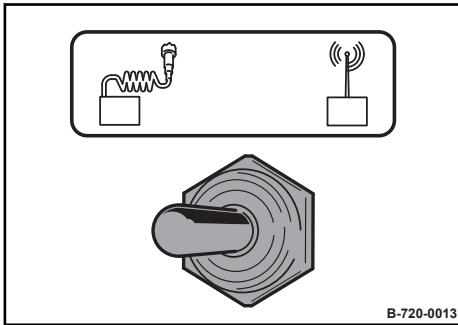

Position "left"

Cable operation

Position "right"

Radio operation

Fig. 33

## 4.3 Display module

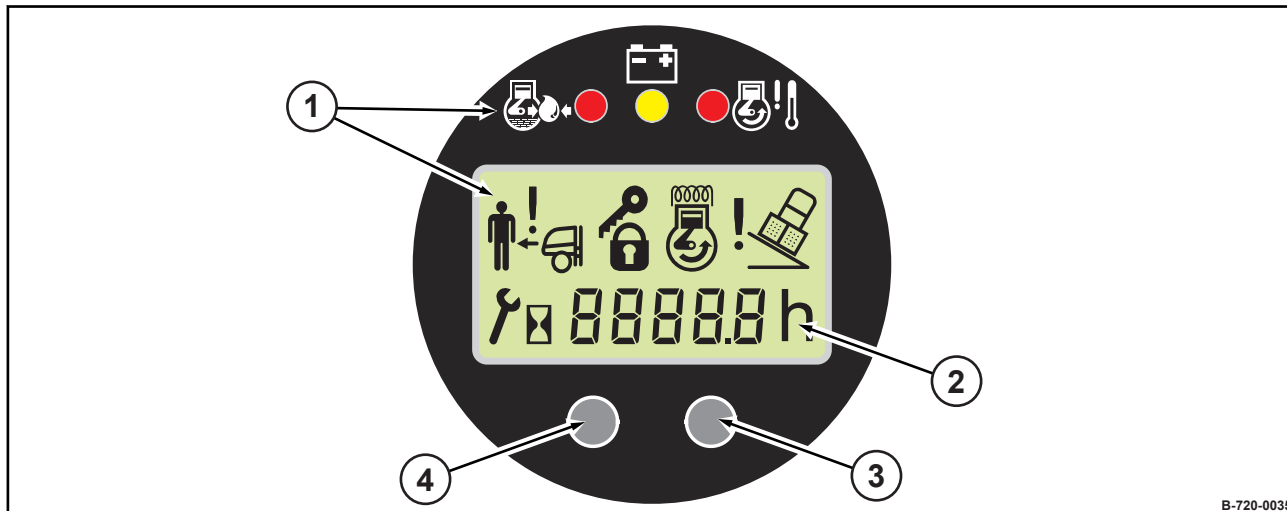

Fig. 34

- 1 Control and warning lights
- 2 Display field for operating hours and fault codes
- 3 Function key F2
- 4 Function key F1

### Control and warning lights

	Designation	Note
	Engine oil pressure warning light	Lights up if the engine oil pressure is too low. The engine is shut down after a short while. Check the engine oil level; if necessary, repair the engine.
	Charge control light	Lights up if the battery is not being charged. Check the V-belt drive, if necessary repair the generator.
	Coolant temperature warning light	Lights up if the coolant temperature is too high. Run the engine at idle speed or, if necessary, shut it down and clean the radiator; if necessary, repair the engine.
	Safety device warning light	Lights up when the operator with the remote control is within the safety field. The machine stops immediately. To continue leave the machine's safety field or move the machine in the opposite direction.
	Pre-heating control light	Lights up during pre-heating.
	Tipping angle warning light	Lights when the tipping angle of the machine has reached 45° in lateral direction or 60° in travel direction. The engine is shut down. To continue restart the engine and move the machine carefully out of the danger zone.

### 4.4 Main battery switch

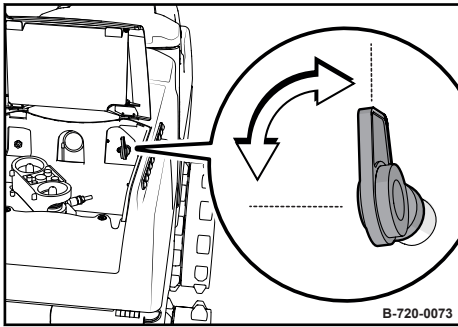
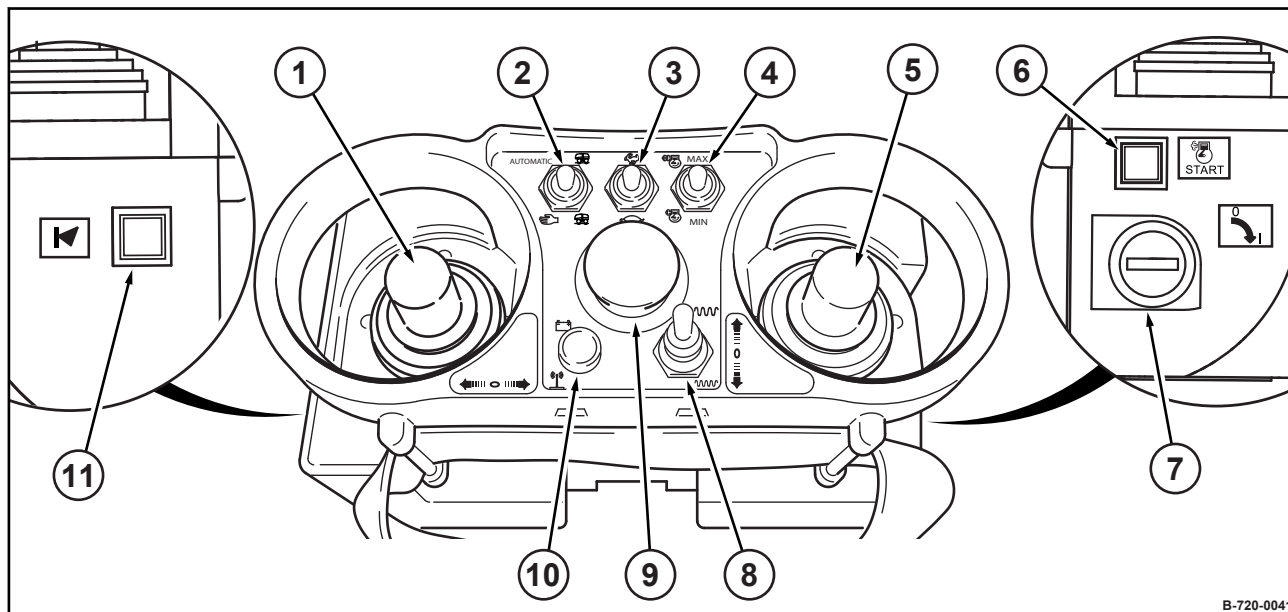

Fig. 35

Position "on"	Main battery switch locked Normal position, operation
Turn anticlockwise	Main battery switch can be pulled out Disconnects the batteries from the on-board electrics, e.g. to prevent unauthorised use  Individual control units may still be connected to the on-board electrics despite the main battery switch being pulled out

## 4.5 Remote control



B-720-0041

Fig. 36

- 1 Steering lever
- 2 Vibration pre-selection toggle switch
- 3 Toggle switch for travel ranges
- 4 Engine speed toggle switch
- 5 Travel lever
- 6 Start button
- 7 Starter switch
- 8 Vibration toggle switch
- 9 Emergency stop switch
- 10 Radio operation control light
- 11 Button for warning horn

### 4.5.1 Steering lever

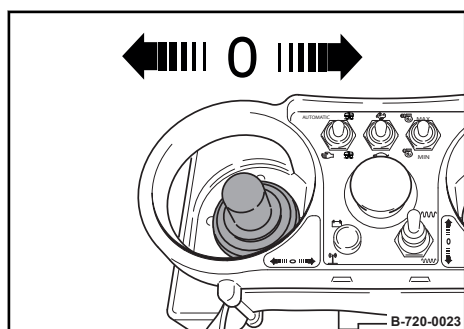

B-720-0023

Shift to the left	Machine steers to the left
Shift to the right	Machine steers to the right

Fig. 37

### 4.5.2 Vibration pre-selection toggle switch

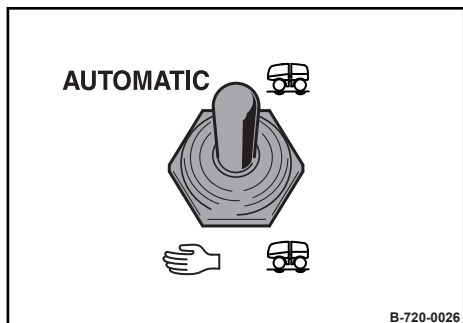

Fig. 38

Position "front"	Pre-selection "automatic" Vibration is automatically switched on or off when the travel speed exceeds or falls below a certain value.
Position "rear"	Pre-selection "manual" Vibration is switched on or off using the vibration toggle switch.

### 4.5.3 Toggle switch for travel ranges

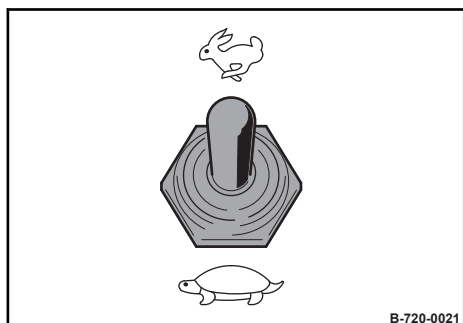

Fig. 39

Position "front"	Travel speed range 2
Position "rear"	Travel speed range 1

**i** *Vibration is automatically switched off in travel speed range 2.*

### 4.5.4 Engine speed toggle switch

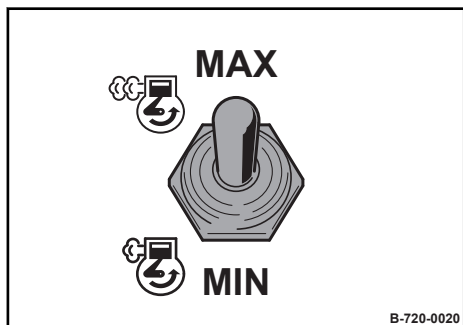

Fig. 40

Position "front"	Full load position
Position "rear"	Idle speed position

#### 4.5.5 Travel lever

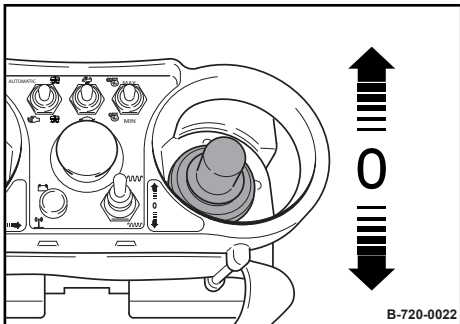

Fig. 41

Shift forward

Forward travel

Pull back

Backward travel

#### 4.5.6 Starter switch

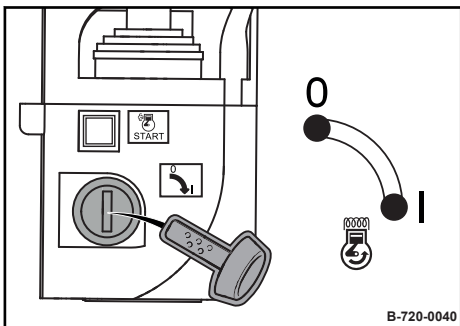

Fig. 42

Position "0"

Ignition off, key can be pulled out

Position "I"

Ignition on: charge control light and engine oil pressure warning light light up (test function).

At low temperatures, the preheating control light lights up on the display module.

#### 4.5.7 Start button

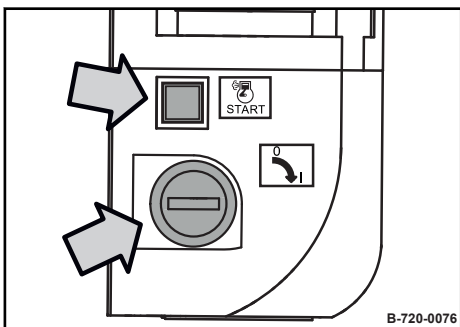

Fig. 43

Set the starter switch to position "I" and press it

The engine starts.



#### 4.5.8 Vibration toggle switch

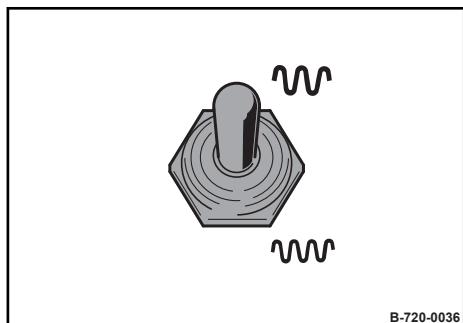

Position "front"	High amplitude
Position "middle"	Vibration off
Position "rear"	Low amplitude

Fig. 44

#### 4.5.9 Emergency stop switch

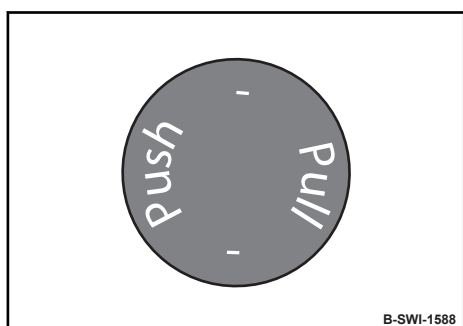

Press	In emergency situations and in case of danger, actuate the emergency stop switch immediately by pressing it down fully. It automatically locks in end position.  The machine will be braked immediately. The engine is shut down.
Switching off/ unlocking	Pull up the emergency stop switch as far as it will go.

Fig. 45

#### 4.5.10 Button for warning horn

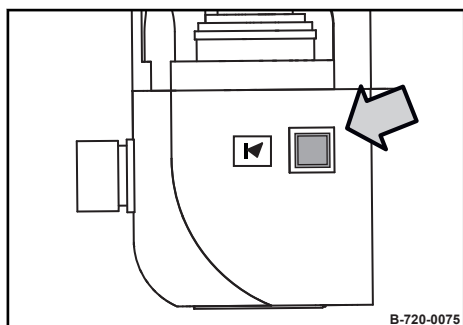

Press	Warning horn sounds
-------	---------------------

Fig. 46

4.5.11 Radio operation control light

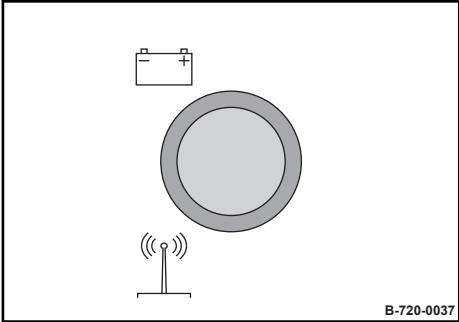



Fig. 47

	<p>Flashes green when the radio remote control is switched on</p>
	<p>Lights up red when the battery charge in the remote control drops too low.</p> <p>The machine is automatically switched off after 10 minutes if the battery is not charged or if it is replaced.</p> <p>A warning signal also sounds 1 minute prior to shutdown.</p> <p>Connect the remote control to the cable as soon as it lights up and switch the machine to cable operation (battery is charged) or replace the battery.</p>



### 5.1 Notes on safety

If the following tests reveal damages or other defects, the machine must not be operated, until these deficiencies have been corrected.

Do not operate the machine with defective indicators and control elements.

Safety installations must not be removed or made ineffective.

Do not change any fixed settings.



#### **WARNING!**

##### **Health hazard caused by fuels and lubricants!**

- Safety regulations and environmental protection regulations must be followed when handling fuels and lubricants ↪ *Chapter 3.4 'Handling fuels and lubricants' on page 27.*



#### **WARNING!**

##### **Danger of injury caused by rotating parts!**

- Before starting work on the machine make sure that the engine can not be started.

1. Park the machine safely ↪ *Chapter 6.6 'Parking the machine in secured condition' on page 93.*
2. Open the protective hoods and secure them.
3. Close the protective hoods after work is completed.

### 5.2 Visual inspections and function tests

1. Check the condition of the hydraulic oil tank and hydraulic lines and for leaks.
2. Check the condition of the fuel tank and fuel lines and for leaks.
3. Check the cooling system for contamination, damage and leaks.
4. Check the bolted connections are tight and secure.
5. Check the engine and exhaust system for leaks.
6. Check the belt drive for damage.
7. Check the machine and remote control for contamination and damage.

## Checks prior to start up – Checking the engine oil level

### 5.3 Checking the engine oil level

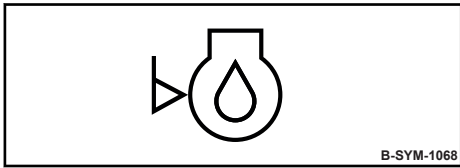

Fig. 48



#### NOTICE!

##### Danger of engine damage!

- If the engine is warm, shut it down and check the oil level after five minutes. With a cold engine the oil level can be checked immediately.
- Use only oil of the permitted specification  
↳ *Chapter 8.3.1 'Engine oil' on page 109.*

Protective equipment: ■ Working clothes  
■ Safety shoes  
■ Protective gloves

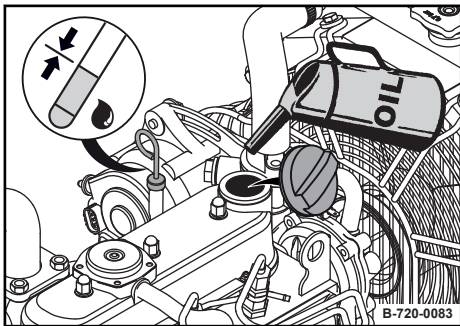

Fig. 49

1. Clean the area around the oil dipstick.
2. Pull the dipstick out, wipe it off with a lint-free, clean cloth and reinsert it to the end stop.
3. Pull the dipstick out again.  
⇒ The oil level must be between the "MIN" and "MAX" marks.
4. For topping up, clean the area around the filling port.
5. Unscrew the cap and fill with engine oil up to the "MAX" mark.
6. Insert the dipstick.
7. Close the cap.

### 5.4 Checking the fuel level; topping up fuel

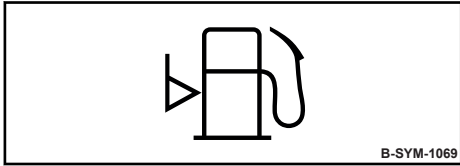

Fig. 50



#### NOTICE!

##### Danger of engine damage!

- Never run the fuel tank empty, as otherwise the fuel system needs to be bled.
- Monitor the entire refuelling process.
- Contaminated fuel can cause malfunction or even damage of the engine. If necessary, fill in fuel through a screen filter.
- Use only fuel of the permitted specification  
↳ Chapter 8.3.2 'Fuel' on page 110.

1. Check the filling level in the fuel tank.
2. Refuel, if required, after first shutting down the engine.

#### Refuelling

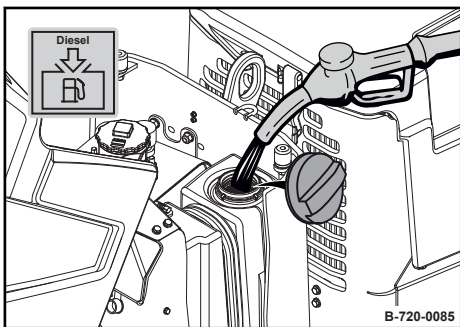

Fig. 51

Protective equipment: ■ Working clothes  
■ Safety shoes  
■ Protective gloves

1. Clean the area around the filling port.
2. Unscrew the cap and fill with fuel.
3. Close the cap.

### 5.5 Checking the hydraulic oil level

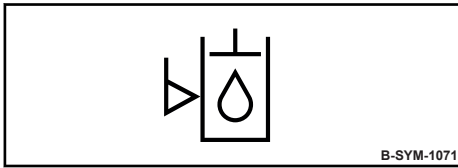

Fig. 52



#### NOTICE!

##### Components may get damaged!

- Check the hydraulic oil level at room temperature (approx. 20 °C (68 °F)).
- If, during the daily inspection of the oil level the hydraulic oil level is found to have dropped, check all lines, hoses and components for leaks.
- Use only oil of the permitted specification  
↳ Chapter 8.3.5 'Hydraulic oil' on page 112.

- Protective equipment:
- Working clothes
  - Safety shoes
  - Protective gloves

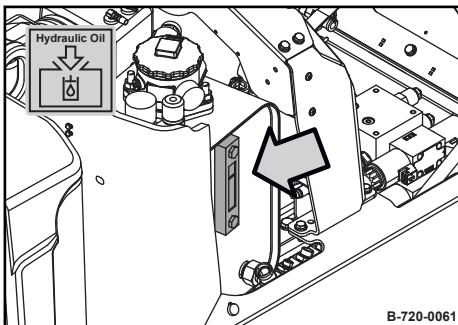

Fig. 53

1. Check the oil level in the inspection glass.

Normal level	Approx. 3 cm (1.2 in) below the top edge of the inspection glass
Minimum level	Approx. middle of inspection glass

2. If necessary, check the lines, hoses and units for leaks.



*In the event of an internal leakage in the hydraulic system, hydraulic oil might collect in the travel drive or exciter shaft housing.*

3. If necessary, check the travel drive or exciter shaft housing  
↳ Chapter 10 'Troubleshooting' on page 155.
4. For topping up, clean the area around the filling port.
5. Remove the cap and fill with hydraulic oil.
6. Close the cap.



### 5.6 Checking the coolant level

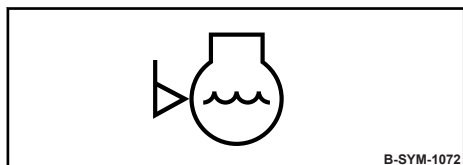

Fig. 54



#### NOTICE!

##### Danger of engine damage!

- If, during the daily inspection the coolant level is found to have dropped, check all lines, hoses and engine for leaks.
- Do not use radiator sealant to seal leaks.
- Use only coolant of the permitted specification  
↳ Chapter 8.3.3 'Coolant' on page 111.

Protective equipment:

- Working clothes
- Safety shoes
- Protective gloves
- Safety goggles

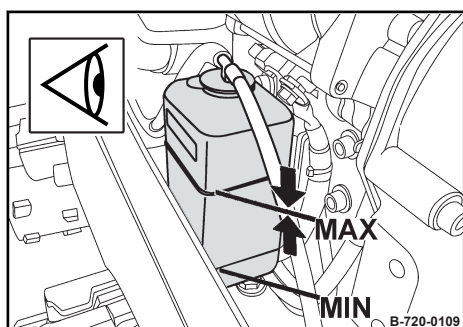

Fig. 55

1. Check the coolant level in the compensation tank.  
⇒ The coolant level must be between the "MIN" and "MAX" marks.



#### WARNING!

##### Danger of scalding by hot fluid!

- Open the compensation tank only when the engine is cold.
- Wear your personal protective equipment (protective gloves, protective clothing, goggles).

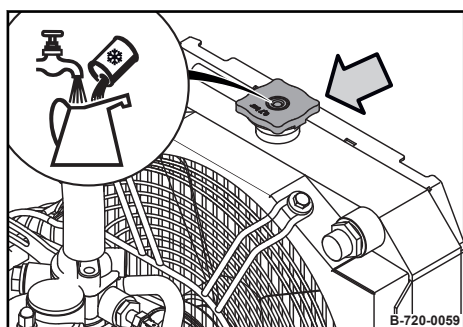

Fig. 56

2. For topping up, clean the area around the filling port.
3. Unscrew the cap and fill with coolant up to the "MAX" mark.
4. Close the cap.

### 5.7 Checking the rubber buffers

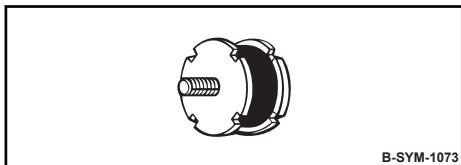

Fig. 57

Protective equipment: ■ Working clothes  
■ Safety shoes  
■ Protective gloves

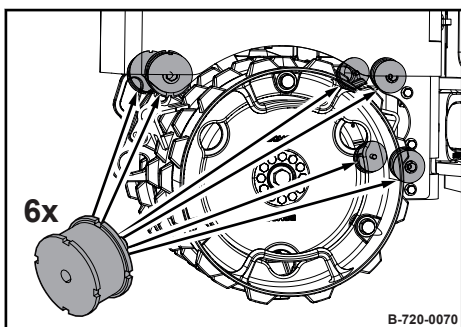

Fig. 58

1. Check the six rubber buffers on both the front and rear axle are tight and secure, and check for cracks and tears.
2. Replace damaged rubber buffers immediately.



### 6.1 Preliminary remarks

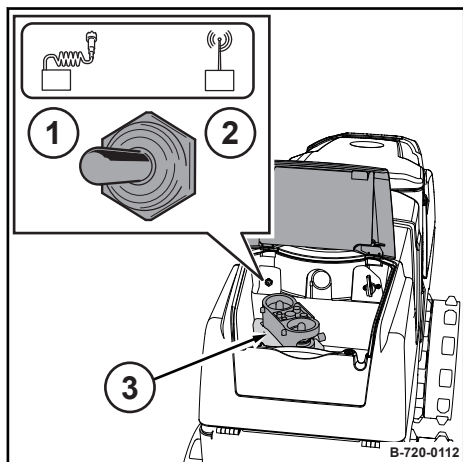

Fig. 59

The machine is operated by remote control (3).

Depending on how it is equipped, this may be in two operating modes:

- Cable operation (1)
- Radio operation (2)

In both operating modes, the remote control functions are the same.

However, for radio operation special operating instructions and performance tests have to be taken into account.

### 6.1.1 BOSS safety system



#### BOSS: BOMAG OPERATOR SAFETY SYSTEM

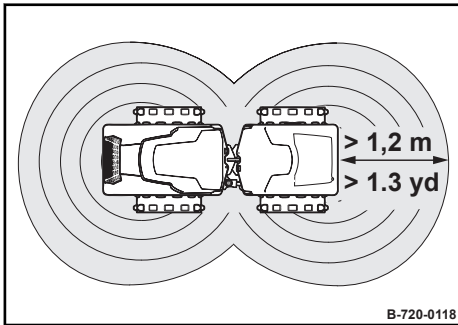

The BOSS safety system protects the operator in close proximity to the machine. For this purpose, the machine is surrounded by two spherical electromagnetic safety fields.

The safety fields only protect the operator with the remote control associated with the machine (same system numbers). Other persons or unrelated remote controls or objects in the danger zone are not protected.

Fig. 60

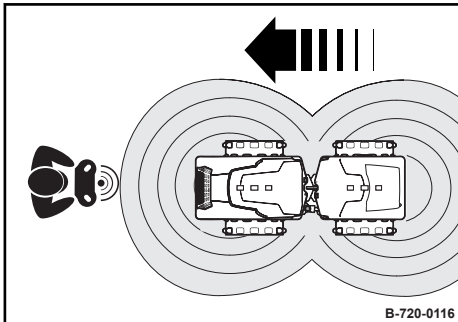

If the machine moves directly towards the operator, the machine stops immediately when the front protective field is entered. To continue driving, the safety field must be left or the machine moved in the opposite direction of travel.

Fig. 61

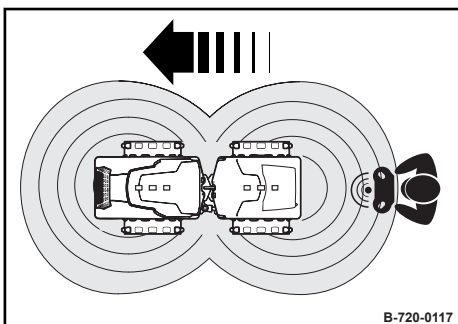

If the machine moves away from the operator, the operator can enter the rear safety field a short distance before the machine is stopped. To continue driving the safety field must be left.

Fig. 62

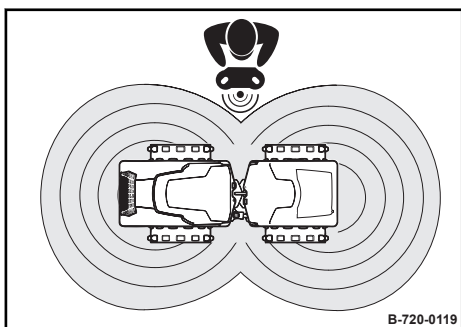

Fig. 63

If the operator is in the middle between the machine halves in both safety fields, both travel directions of the machine are blocked.

The operator must be familiar with the size of the safety fields and check the function of the safety device at each start-up ↪ *Chapter 6.2.3 'Checking the BOSS safety system' on page 81.*

### 6.1.2 Notes on radio operation

#### 6.1.2.1 Remote disconnection

The machine stops and the engine is shut down when the machine leaves the remote control range.

To continue travelling reduce the distance and restart the engine ↪ *Chapter 6.2.4 'Starting the engine' on page 83.*

#### 6.1.2.2 Radio interference

If the radio connection between the remote control and the machine is interrupted or disturbed for more than two seconds, the machine stops and the engine is switched off.

To continue travelling move into the radio transmission range of the machine and restart the engine ↪ *Chapter 6.2.4 'Starting the engine' on page 83.*

### 6.1.2.3 Decrease in battery voltage

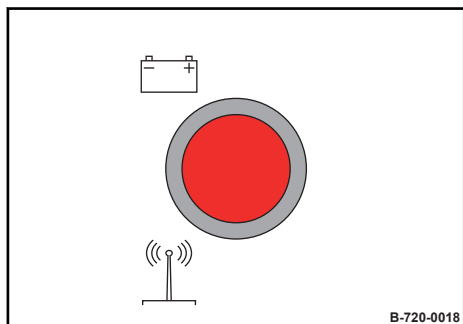

Fig. 64

If the battery voltage drops too much during operation, the radio operation control light goes red (approx. 10 minutes before the machine stops).

If the battery voltage drops further, the warning buzzer sounds additionally (approx. 1 minute before the machine stops).

If the remote control battery is empty, the machine stops and the engine is switched off.

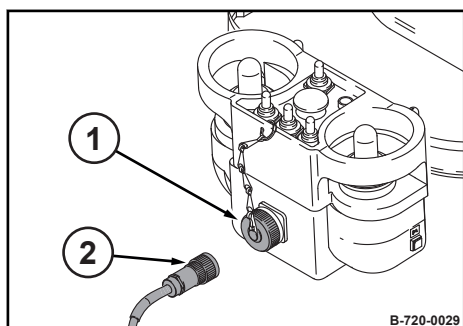

Fig. 65

1. When the control light lights up, drive the machine to a safe place and stop.
2. Remove the safety cap (1) and connect the cable (2) to the remote control.
  - ⇒ The battery starts charging.

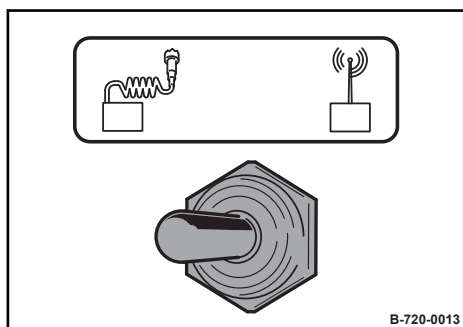

Fig. 66

3. Switch to cable operation with the toggle switch.
4. If the engine is off, restart the engine ↪ *Chapter 6.2.4 'Starting the engine' on page 83.*
5. Continue to operate the machine in cable mode.

### 6.2 Start-up procedure

#### 6.2.1 Preparing the remote control

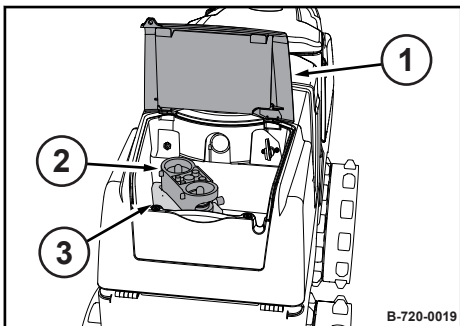

Fig. 67

1. Open the flap (1) and take the remote control (2) out of the holding fixture (3).

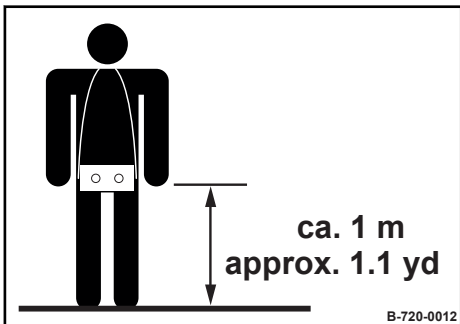

Fig. 68

2. Strap on the remote control and hold in front of your body.

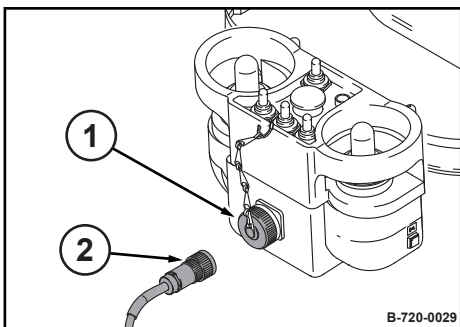

Fig. 69

3. During cable operation, remove the safety cap (1) and connect the cable (2) to the remote control.

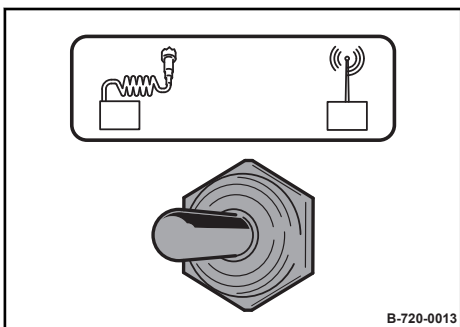

Fig. 70

4. Use the toggle switch to select the required operating mode.



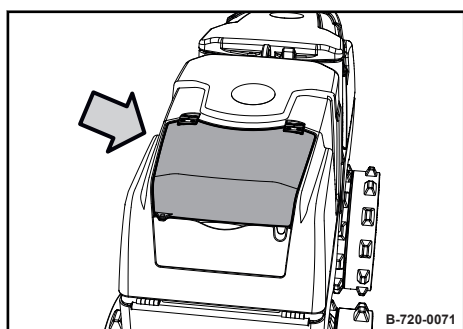

Fig. 71

5. Close the flap.

### 6.2.2 Checking the remote control

#### Preparations

- Protective equipment:
- Working clothes
  - Safety shoes
  - Protective gloves
  - Hearing protection

#### Prerequisites:

- Main battery switch is switched on
  - Emergency stop switch is unlocked
1. Prepare the remote control ↪ *Chapter 6.2.1 'Preparing the remote control' on page 76.*
  2. If several machines are used at the same time, compare the system numbers on the remote control and receiver.
    - ⇒ The system numbers on both devices must match.
  3. Exchange the remote control, if necessary.
  4. Switch the toggle switch for engine speed to "MIN" position.

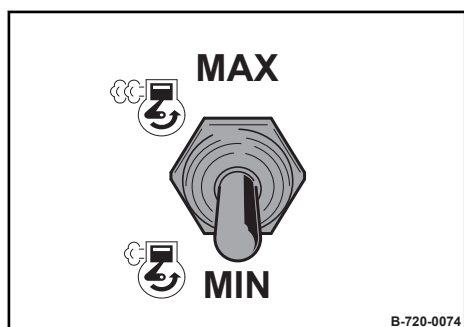

Fig. 72

## Operation – Start-up procedure

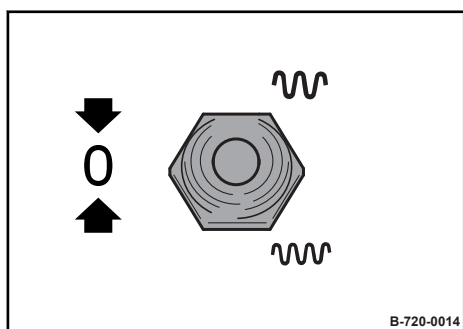

Fig. 73

5. Set the vibration toggle switch to "middle" position.

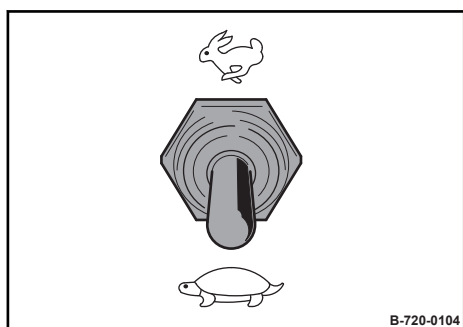

Fig. 74

6. Switch the toggle switch for travel speed ranges to the "rear" position.

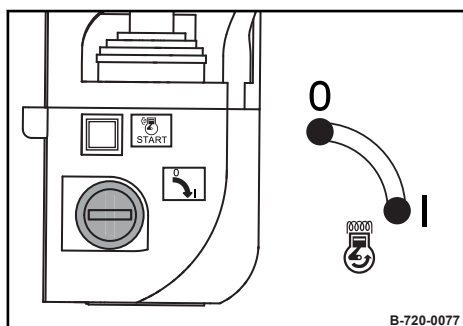

Fig. 75

7. Turn the ignition key to position "I".

### Checking the remote control

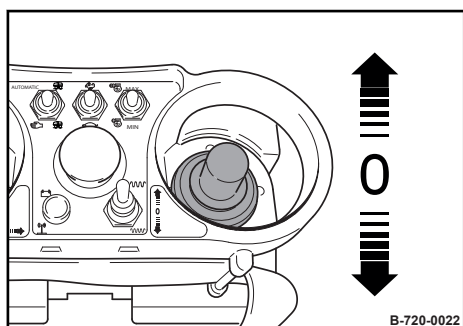

Fig. 76

1. Shift the travel lever forwards or backwards and hold in place.

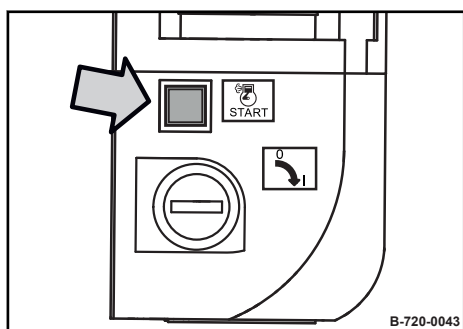

Fig. 77

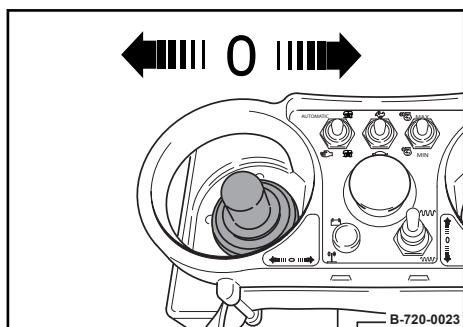

Fig. 78

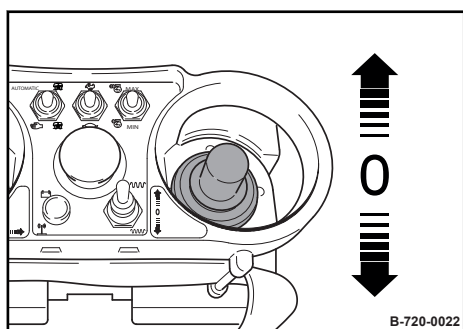

Fig. 79

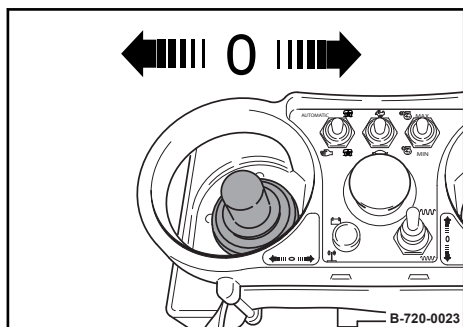

Fig. 80

2. Press the start button.  
⇒ The engine should not start.
3. Release the travel lever and check that it returns to the neutral position on its own.

**i** *The automatic return to neutral position can be impaired by dirt (e.g. mortar, concrete residues).*

4. If necessary, clean the travel lever with a clean cloth or brush.
5. Shift the steering lever to the left or right and hold in place.
6. Press the start button again.  
⇒ The engine should not start.
7. Release the steering lever and check that it returns to the neutral position on its own.

**i** *The automatic return to neutral position can be impaired by dirt (e.g. mortar, concrete residues).*

8. If necessary, clean the steering lever with a clean cloth or brush.
9. Start the engine.
10. Before starting to drive make sure that the driving area is absolutely safe.
11. Move the travel lever slowly forwards or backwards.  
⇒ Make sure the machine travels in the chosen direction.

12. Shift the steering lever to the left or right.  
⇒ Make sure the machine steers in the chosen direction.
13. Release the travel lever.  
⇒ Make sure the machine brakes until it comes to a standstill.

## Operation – Start-up procedure

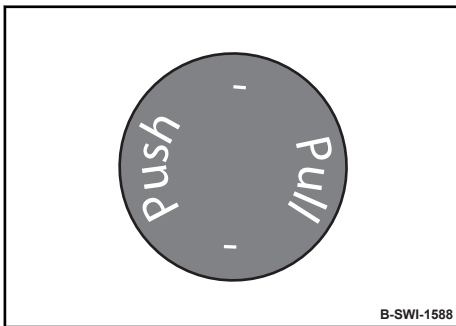

Fig. 81

14. Actuate the emergency stop switch.  
⇒ Make sure the machine stops and the engine is shut down.
15. If necessary, switch off the engine manually ↗ *Chapter 10.2 'Switching off the machine manually' on page 157.*
16. If this does not work correctly, shut down the remote control and notify our Customer Service Department.
17. Only operate the machine again after it has been repaired.

### 6.2.3 Checking the BOSS safety system

- Protective equipment:
- Working clothes
  - Safety shoes
  - Protective gloves
  - Hearing protection

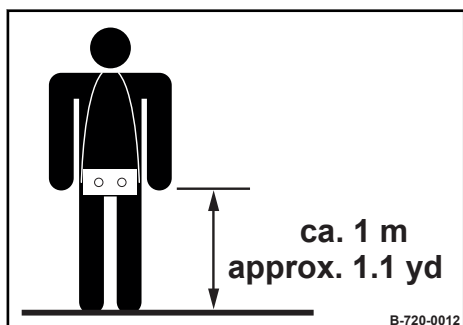

Fig. 82

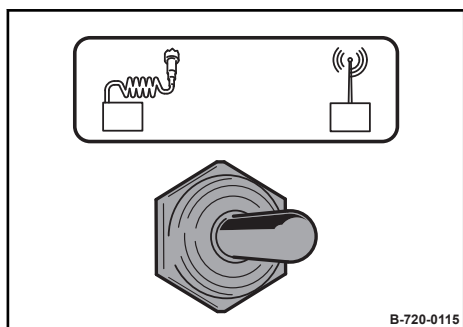

Fig. 83

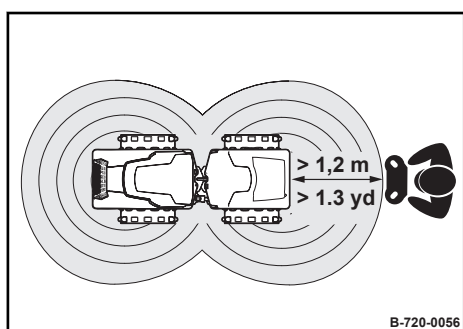

Fig. 84

1. Strap on the remote control and hold in front of your body.



*To check the safety device make sure the distance from the remote control to the floor is 1 m (1.1 yd).*

2. Turn the toggle switch for operating mode to the “right” position.
3. Start the engine ↪ *Chapter 6.2.4 ‘Starting the engine’ on page 83.*

4. Walk behind the machine with the remote control.
5. Let the machine travel towards you slowly until it stops.
6. Measure the distance between the machine and the remote control housing.

Nominal value	> 1.2 m (1.3 yd)
---------------	------------------

## Operation – Start-up procedure

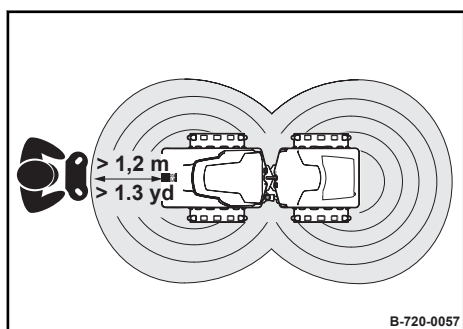

Fig. 85

7. Repeat the measurement of the safety field in front of the machine.
8. If the distance behind or in front of the machine is too small, check the safety device and have it repaired.

### 6.2.4 Starting the engine



#### WARNING!

Loss of hearing caused by too high noise burdens!

- Wear your personal protective equipment (ear protection).

- Protective equipment:
- Working clothes
  - Safety shoes
  - Protective gloves
  - Hearing protection

#### Prerequisites:

- Main battery switch is switched on
- The protective hoods and flap are closed and locked
- Emergency stop switch is unlocked
- The travel lever and steering lever are in neutral position

1. Switch the toggle switch for engine speed to "MIN" position.

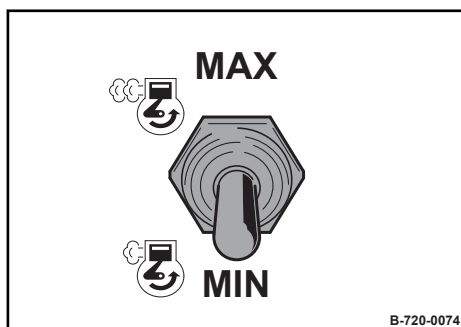

Fig. 86

2. Set the vibration toggle switch to "middle" position.

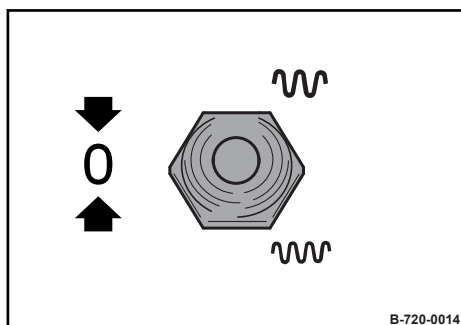

Fig. 87

## Operation – Start-up procedure

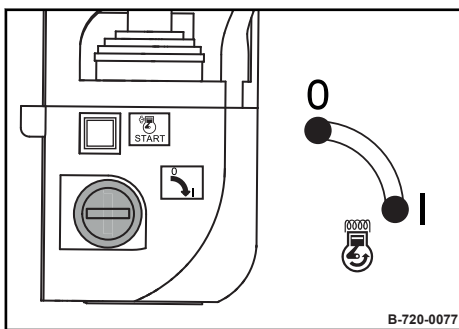

Fig. 88

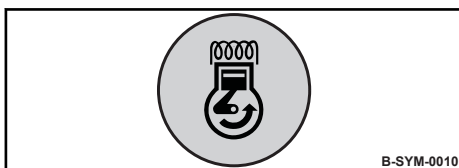

Fig. 89

3. Turn the ignition key to position "I".

⇒ The preheating control light on the display module lights up.

The machine type code is displayed on the display module screen for approx. 3 s.

The horn signal sounds on the machine as soon as the machine is ready for operation.

**i** *If the horn does not sound, the machine is faulty.*

Two buzzer signals sound on the remote control as soon as the remote control is ready for operation.

**i** *If the buzzer does not sound, there is a fault in the remote control or the battery is empty (for radio remote control).*

4. With cold outside temperatures, wait up to 10 seconds before starting (pre-warming).
5. Press the start button.

⇒ The starter cranks the engine.

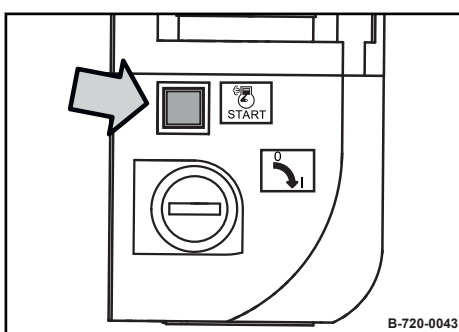

Fig. 90



### NOTICE!

#### Danger of engine damage!

- Warm up engine for a short while before starting work. Do not operate the engine immediately under full load.



## 6.3 Travel operation

### 6.3.1 Preliminary remarks and safety notes



**DANGER!**

**Danger to life caused by the machine turning over!**

- Never drive across a slope.
- Always drive straight up or down a slope.

Do not drive on gradients exceeding the maximum gradeability of the machine.

Soil conditions and weather influences impair the gradeability of the machine.

Wet and loose soil considerably reduces traction of the machine on inclinations and slopes. Greater danger of accident!

### 6.3.2 Driving the machine

- Protective equipment:
- Working clothes
  - Safety shoes
  - Protective gloves
  - Hearing protection

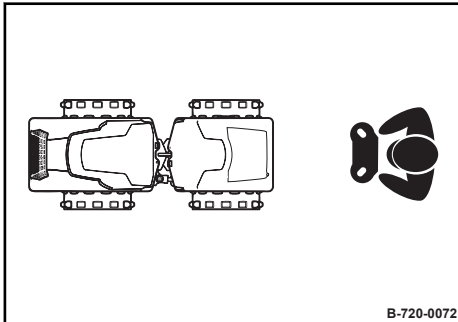

Fig. 91

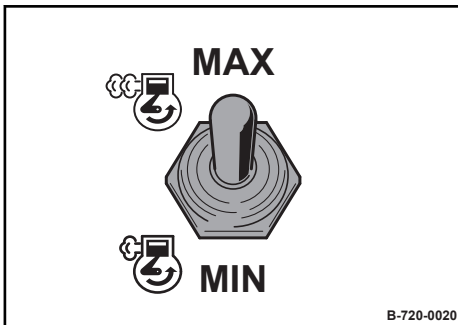

Fig. 92

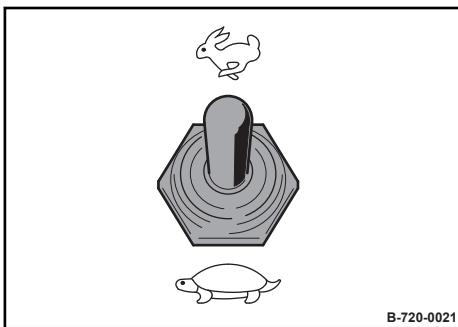

Fig. 93

1. Take your place as operator behind the machine.

2. Switch the toggle switch for engine speed to the "front" position.

- 3.



**WARNING!**

**Injury caused by the machine turning over!**

- Do not activate travel speed range 2 when operating without a drum extension.

Use the toggle switch for travel speed ranges to select the required travel speed range.

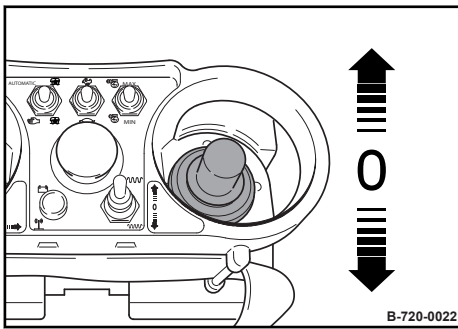

Fig. 94

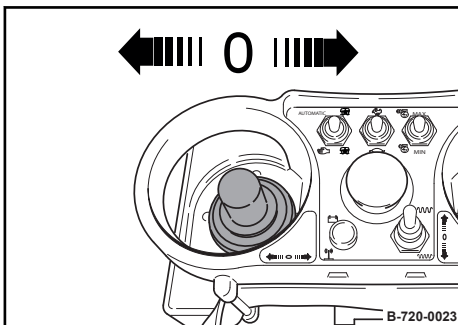

Fig. 95

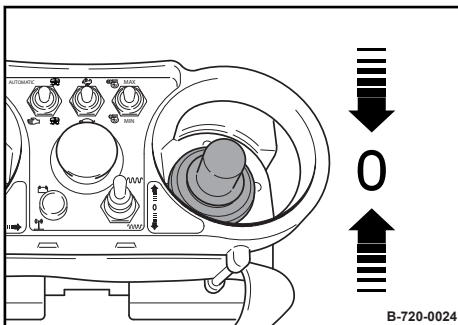

Fig. 96

4. Before starting to drive make sure that the driving area is absolutely safe.
5. Move the travel lever forwards or backwards.
  - ⇒ The machine travels in the required travel direction.
6. Shift the steering lever to the left or right.
  - ⇒ The machine steers in the corresponding direction.
7. Set the travel lever to “middle” position to stop the machine.
  - ⇒ The machine decelerates to a standstill.

### 6.4 Working with vibration

#### 6.4.1 Preliminary remarks and safety notes



##### **NOTICE!**

##### **Possible damage to neighbouring buildings!**

- When compacting with vibration you must always check the effect of the vibration on nearby buildings and underground supply lines (gas, water, sewage, electric power).
- If necessary stop compacting with vibration.



##### **NOTICE!**

##### **Components may get damaged!**

- Do not activate the vibration on hard (frozen, concrete) ground.

Vibration at standstill causes transverse marks:

- Switch the vibration on only after shifting the travel lever in the desired travel direction.
- Switch the vibration off before stopping the machine.

In automatic mode, vibration is automatically activated when the machine starts moving. When it stops, the vibration switches off automatically.

This avoids the formation of transverse marks caused by vibration with the machine at standstill.

#### 6.4.2 Vibration in automatic mode

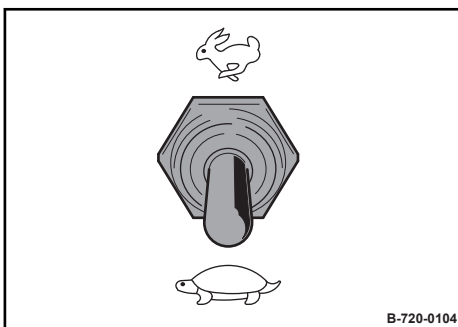
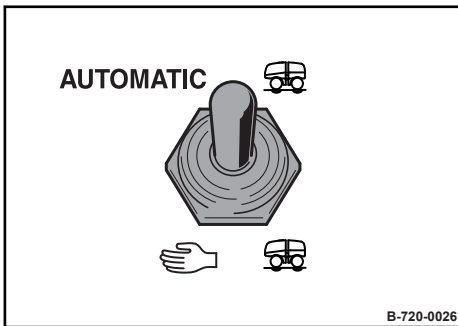

Fig. 97

1. Switch the toggle switch for travel speed ranges to the “rear” position.



B-720-0026

Fig. 98

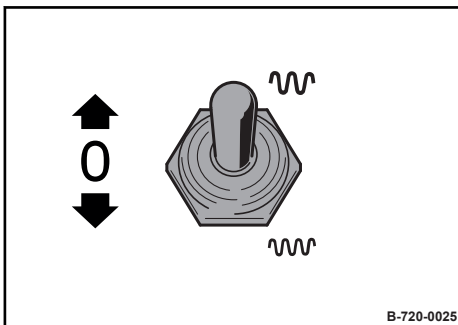

B-720-0025

Fig. 99

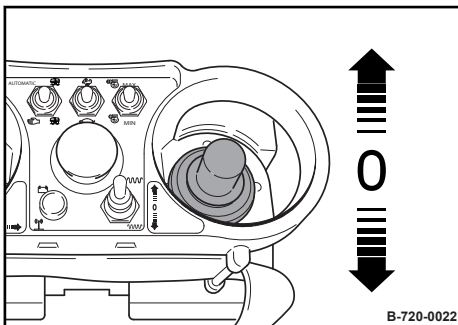

B-720-0022

Fig. 100

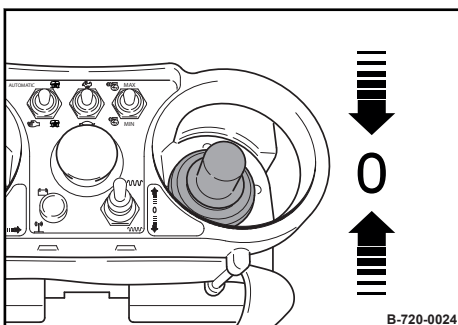

B-720-0024

Fig. 101

2. Switch the toggle switch for vibration pre-selection to the "front" position.
3. Use the toggle switch for vibration to pre-select the required amplitude.
4. Move the travel lever forwards or backwards.
  - ⇒ The machine travels in the required travel direction and the vibration is switched on.
5. To switch off vibration return the travel lever towards the "middle" position.
  - ⇒ The vibration is switched off and the machine brakes until it comes to a halt.

## Operation – Working with vibration

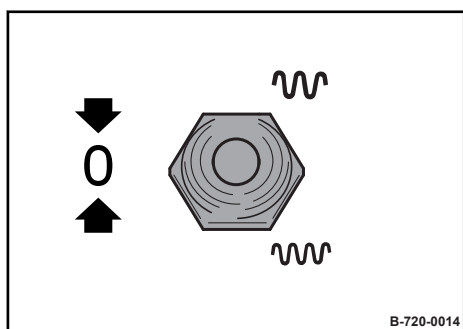

Fig. 102

6. After finishing work, switch the toggle switch for vibration to the “middle” position.

### 6.4.3 Manual vibration

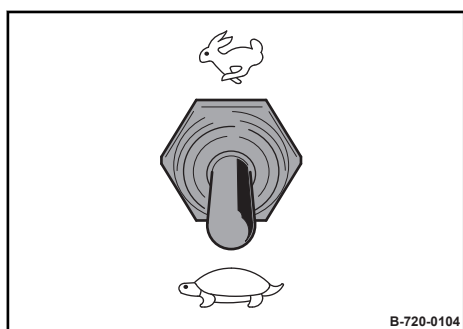

Fig. 103

1. Switch the toggle switch for travel speed ranges to the “rear” position.

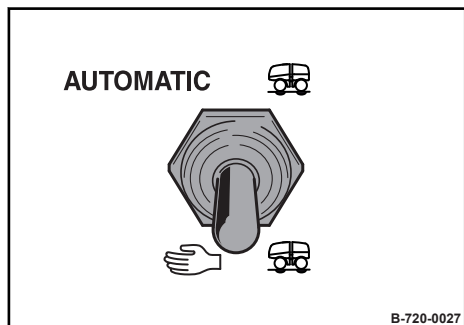

Fig. 104

2. Switch the toggle switch for vibration pre-selection to the “rear” position.

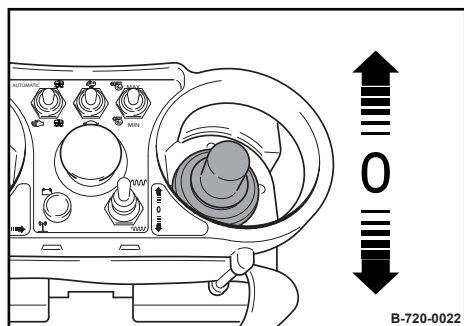

Fig. 105

3. Shift the travel lever slowly in the desired travel direction.

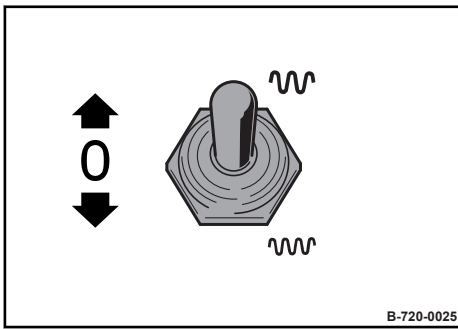

Fig. 106

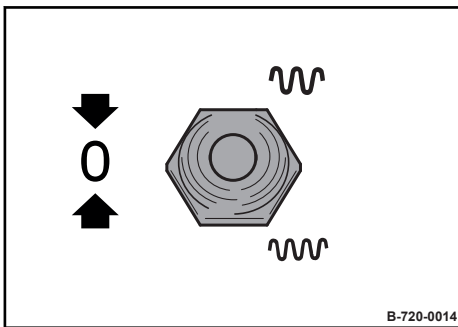

Fig. 107

4.



**NOTICE!**

**Vibration at standstill causes transverse marks!**

- Do not switch on vibration with the machine at standstill.

Use the toggle switch for vibration to switch on the vibration at the required amplitude.

5.

To switch vibration off switch the toggle switch for vibration to the "middle" position.

### 6.5 ECONOMIZER

The ECONOMIZER informs the driver about the compaction status of the subsoil and enables the detection and selected re-compaction of weak spots.

An acceleration transducer measures the reaction of the subsoil on the vibrating drum.

#### Start process

The ECONOMIZER is automatically started by switching the ignition on.

The ECONOMIZER first of all runs an LED-test. The LEDs light up one after the other, starting with LED (1). Once all LEDs are on, the display goes out again in single steps.

#### Measuring operation

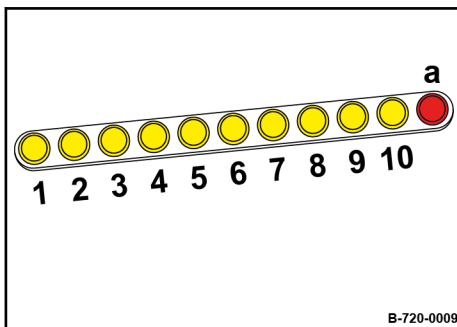

Fig. 108

With the vibration switched on, the measuring value is displayed by the LED-display (1-10).

If the displayed value does not increase any further with unchanged amplitude, no further compaction can be achieved with the chosen amplitude.

The maximum display value (10) is not always reached.



*Due to fluctuations in the measuring value, the displayed value can vary up/down during a pass.*

*The average of the display reading during the last pass is decisive.*

The status display (a):

- flashes if the drum is in jump operation.
- flashes or lights in case of malfunctions ↪ *Chapter 10.9 'Trouble shooting ECONOMIZER' on page 170.*

#### Comparability of measuring values

In order to achieve the desired compaction condition of the subsoil, one must always perform a suitable reference measurement before compaction is started.

The reference measurement is used to determine which display value of the ECONOMIZER corresponds with the measuring value for soil stiffness.

Display values measured with different amplitudes can only be compared with each other via a reference measurement.



### 6.6 Parking the machine in secured condition

1. Switch the vibration off.
2. Drive the machine onto level, firm ground.
3. Set the travel lever to “middle” position to stop the machine.

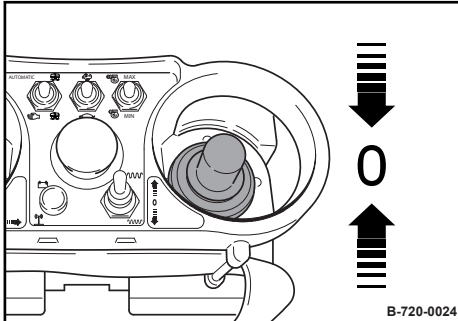

Fig. 109



#### NOTICE!

#### Danger of engine damage!

- Do not shut down the engine all of a sudden from full load speed, but let it idle for about two minutes.

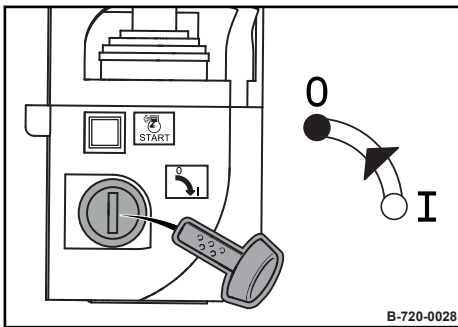

Fig. 110

4. Turn the ignition key to position “0” and pull it out.
5. Open the flap.

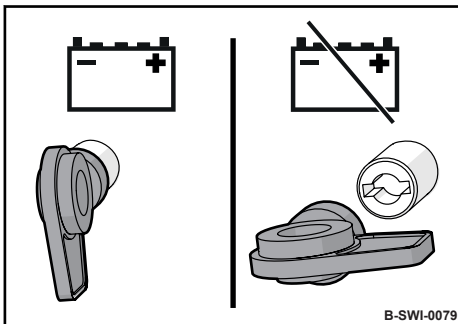

Fig. 111

6. Turn the main battery switch anticlockwise and pull it out.

## Operation – Parking the machine in secured condition

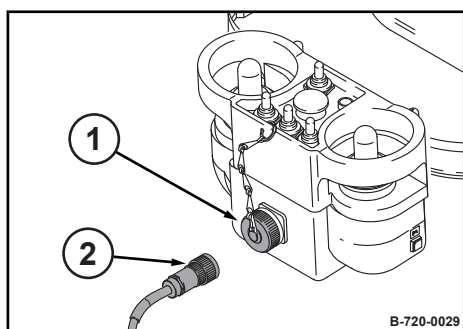

Fig. 112

1. During cable operation, remove the cable (2) and screw on the protective cap (1).

2.



### **NOTICE!**

**Remote control may be damaged by water ingress!**

- Do not clean the remote control with water jets.

After work, clean the remote control with a clean cloth or brush.

3. Place the remote control (2) in the holding fixture (3) and close the flap (1).

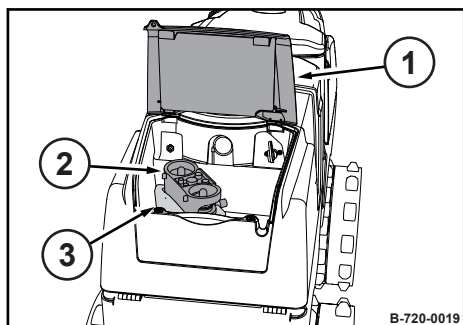

Fig. 113

### 6.7 Remote control battery (radio operation)

The remote control battery can be charged in different ways:

- Charge the battery in the machine via cable.
- Charge the battery in the external battery charger (*optional equipment*).

Battery recharging time is approx. 6 hours.

Remote control operating time with a full charge is approx. 60 hours.

#### 6.7.1 Changing the battery

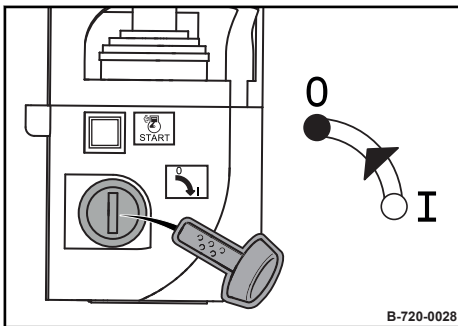

Fig. 114

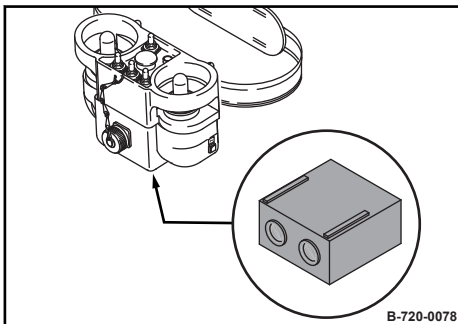

Fig. 115

1. Turn the ignition key to position "0" and pull it out.
2. Press the battery forwards to insert and downwards to remove it from the battery compartment.
3. Insert the replacement battery into the battery compartment and click into place.

### 6.7.2 Charging the power pack in the machine

1. Park the machine safely ↪ *Chapter 6.6 'Parking the machine in secured condition' on page 93.*
2. Switch on the main battery switch.

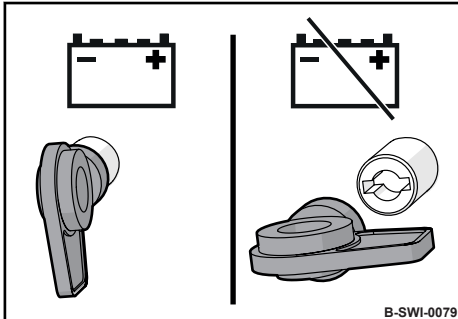

Fig. 116

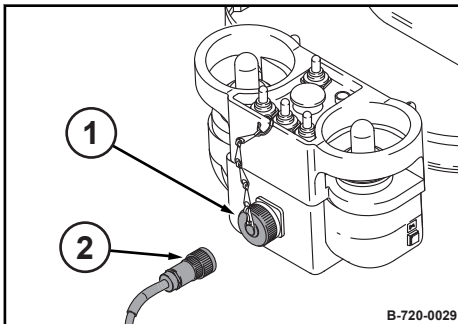

Fig. 117

3. Remove the safety cap (1) and connect the cable (2) to the remote control.  
⇒ The battery starts charging.

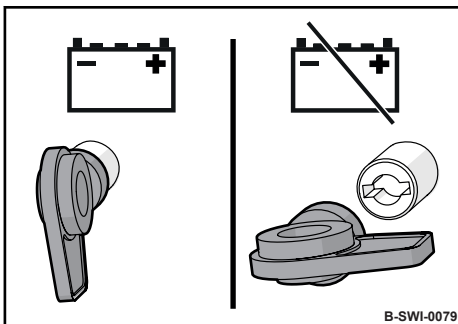

Fig. 118

4. Once the battery is charged, turn the main battery switch anticlockwise and pull it off.

### 6.7.3 Charging the power pack with the external battery charger

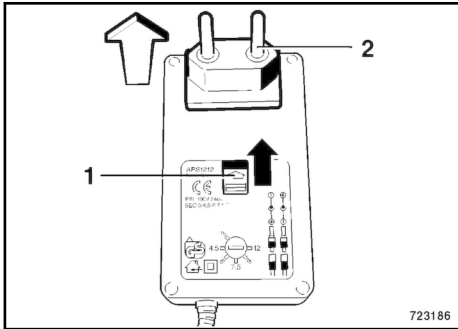

Fig. 119

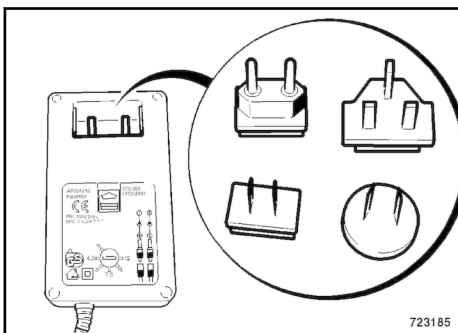

Fig. 120

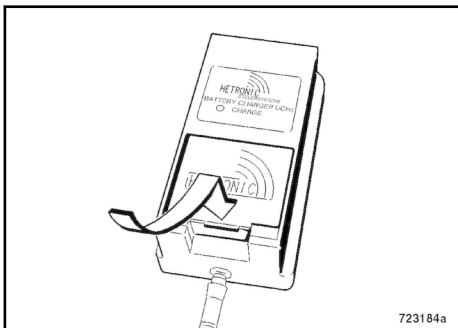

Fig. 121

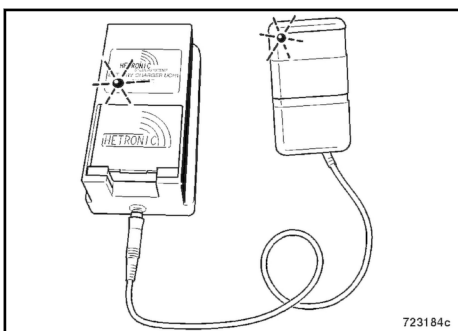

Fig. 122

1. Push the lock (1) on the mains unit of the battery charger forwards and pull the plug (2) upwards out of the mains unit.

2. Plug the country-specific plug onto the mains unit.

3. Remove the battery from the remote control and insert it in the charger.

4. Connect the battery charger mains unit to a power source.



*Make sure the two light emitting diodes on the charger and mains unit light up.*

- ⇒ The green LED on the charger flashes when the battery is charged.





### 7.1 Preparation for transport

1. Remove all loose objects from the machine or fasten them properly.
2. Close and lock all protective hoods and flaps.



## 7.2 Loading the machine

Use only stable loading ramps of sufficient load bearing capacity.

Loading ramps and transport vehicle must be free of grease, oil, snow and ice.

The ramp inclination must be less than the gradeability of the machine.

Make sure that any persons keep a safety distance of at least 2 metres while the machine is driven onto or down from the transport vehicle. The instructing person should not be inside the travel range of the machine.

### Centre-of-gravity position

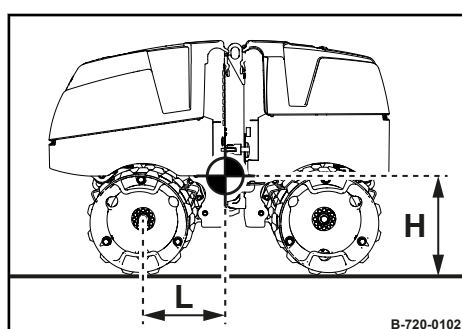

Fig. 123

Distance from middle of front drum	Height
475 mm	512 mm
18.7 in	20.2 in

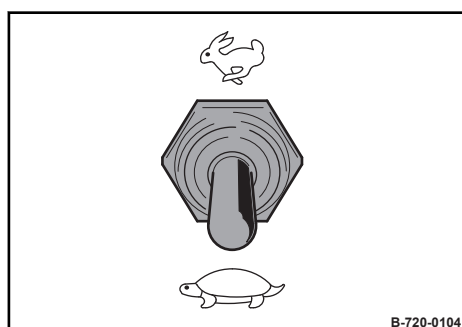

Fig. 124

1. Switch the toggle switch for travel speed ranges to the “rear” position.

2.



**DANGER!**

**Danger to life caused by the machine slipping or turning over!**

- Make sure that no persons are in the danger zone.

Drive the machine carefully onto the transport vehicle.

3. Observe the centre of gravity.
4. Switch off the engine and remove the ignition key.
5. Engage the articulation lock Chapter 8.2.2.1 ‘Engaging the articulation lock’ on page 107.

### **7.3 Lashing the machine to the transport vehicle**

Do not use lifting points that are damaged or impaired in any way.

Always use appropriate lifting and lashing tackle at the lifting points.

Use lifting tackle only in the specified loading direction.

Lifting tackle must not be damaged by machine parts.

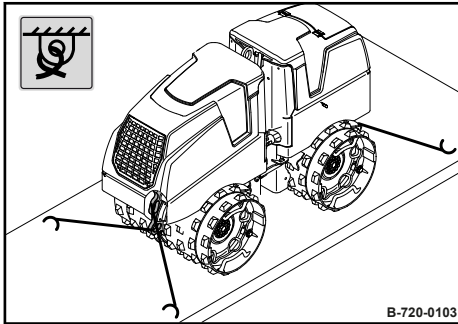

1. Fasten the lashing tackle at the marked lashing points.
2. Securely lash the machine to the transport vehicle using four lashing straps.

*Fig. 125*

### 7.4 Loading by crane

Loads must only be attached and hoisted by an expert / capable person.

Do not use damaged or in any other way impaired lashing points.

Use only lifting gear and lifting tackle with sufficient load bearing capacity for the weight to be loaded. Minimum load bearing capacity of lifting gear: see max. operating weight ↪ *Chapter 2 'Technical data' on page 13.*

Always use appropriate lifting and lashing means on the lifting and lashing points.

Use lifting and lashing gear only in the prescribed direction of load application.

Lifting tackle must not be damaged by machine components.

When lifting the machine avoid uncontrolled movements of the load. If necessary hold the load with guide ropes.

1. Switch off the engine and remove the ignition key.
2. Engage the articulation lock ↪ *Chapter 8.2.2.1 'Engaging the articulation lock' on page 107.*
3. Attach the lifting tackle to the central lifting point.
- 4.

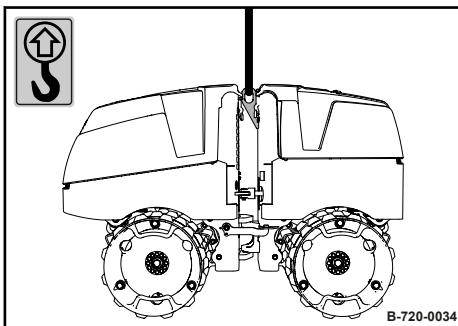

Fig. 126



#### **DANGER!**

**Danger to life caused by suspended loads!**

- Do not step or stand under suspended loads.

Lift the machine carefully and set down again at the intended location.

### 7.5 After transport

Use only stable loading ramps of sufficient load bearing capacity.

Loading ramps and transport vehicle must be free of grease, oil, snow and ice.

The ramp inclination must be less than the gradeability of the machine.

Make sure that any persons keep a safety distance of at least 2 metres while the machine is driven onto or down from the transport vehicle. The instructing person should not be inside the travel range of the machine.

1. Loosen the articulation lock ↪ *Chapter 8.2.2.2 'Disengaging the articulation lock' on page 108.*

2. Switch the toggle switch for travel speed ranges to the "rear" position.

3.



**DANGER!**

**Danger to life caused by the machine slipping or turning over!**

- Make sure that no persons are in the danger zone.

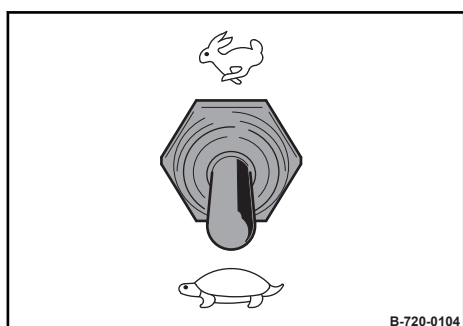

Fig. 127

Drive the machine carefully off the transport vehicle.



### 8.1 Preliminary remarks and safety notes



#### **DANGER!**

#### **Danger to life caused by an operationally unsafe machine!**

- The machine must only be serviced by qualified and authorized personnel.
- Follow the safety regulations for maintenance work ↪ *Chapter 3.11 'Maintenance work' on page 41.*



#### **WARNING!**

#### **Health hazard caused by fuels and lubricants!**

- Safety regulations and environmental protection regulations must be followed when handling fuels and lubricants ↪ *Chapter 3.4 'Handling fuels and lubricants' on page 27.*

Wear your personal protective equipment.

Do not touch hot components.

Park the machine on horizontal, level, firm ground.

Perform maintenance work only with the engine shut down.

Make sure that the engine cannot be accidentally started during maintenance work.

Thoroughly clean the machine and engine before starting maintenance work.

Depressurize hydraulic lines before working on them.

Always attach the articulation lock when working in the area of the articulated joint.

Do not leave any tools or other objects that could cause damage in or on the machine.

After maintenance work has been completed, dispose of fuels and lubricants, filters, sealing elements and cleaning cloths in line with environmental regulations.

After maintenance work is completed reinstall all protective devices.

Close all maintenance flaps and doors after maintenance work has been completed.



*The terms right/left are always in relation to the travel direction.*

### 8.2 Preparations/concluding work

Certain maintenance tasks require preparations and concluding activities.

This includes e.g. opening and closing maintenance flaps and maintenance doors as well as securing certain components.

After this work close all maintenance flaps and doors again and return all components to their operating condition.

#### 8.2.1 Opening the protection hoods

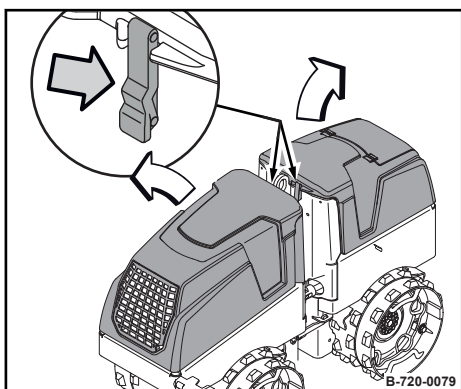

Fig. 128

1. Open the locks and fold the protective hoods forwards or backwards.



*The protective hoods are secured against unintentional tipping over by a safety strap and cannot be completely folded open.*

#### 8.2.2 Engaging/releasing the articulation lock

##### 8.2.2.1 Engaging the articulation lock



#### **WARNING!**

**Danger of crushing by the articulating machine!**

- Do not step into the articulation area of the machine while the engine is running.

1. Move the steering to middle position and stop the machine.
2. Switch off the engine and remove the ignition key.
3. Remove the locking bolt and swivel the articulation lock into the eyelet.
4. Let the locking bolt click into place.

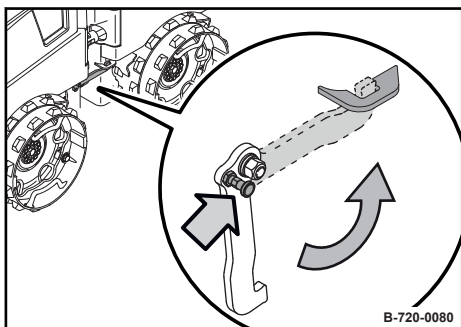

Fig. 129

### 8.2.2.2 Disengaging the articulation lock



#### **WARNING!**

**Danger of crushing by the articulating machine!**

- Do not step into the articulation area of the machine while the engine is running.

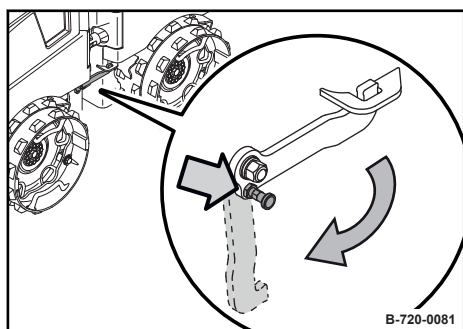

Fig. 130

1. Remove the locking bolt and the articulation lock from the eyelet and swivel back into place in the holding fixture.
2. Let the locking bolt click into place.



### 8.3 Fuels and lubricants

#### 8.3.1 Engine oil

##### 8.3.1.1 Oil quality

The following engine oil specifications are permitted:

- Engine oils according to API classification CF, CF-4, CG-4, CH-4 and CI-4

For operation of an engine with high sulphur fuels we recommend using an engine oil of API classification CF or higher with a total base number of at least 10.

Avoid mixing engine oils.

In North America, use only low-ash engine oils.

##### 8.3.1.2 Oil viscosity

Since engine oil changes its viscosity with the temperature, the ambient temperature at the operating location of the engine is of utmost importance when choosing the viscosity class (SAE-class).

The temperature data of the SAE-class always refer to fresh oils. In travel operation engine oil ages because of soot and fuel residues. This adversely affects the properties of the engine oil, especially under low ambient temperatures.

Optimal operating conditions can be achieved by using the following oil viscosity chart as a reference:

Ambient temperature	Oil viscosity
higher than 25 °C (77 °F)	SAE 30 SAE 10W-30 SAE 15W-40
-10 °C to 25 °C (14 °F to 77 °F)	SAE 10W-30 SAE 15W-40
below - 10 °C (14 °F)	SAE 10W-30

##### 8.3.1.3 Oil change intervals

If the oil change intervals are not reached over a period of one year, the oil change should be performed at least 1 x per year, irrespective of the operating hours reached.

If the sulphur content in the fuel is higher than 0.5 %, the oil change intervals must be halved.

### 8.3.2 Fuel

#### 8.3.2.1 Fuel quality

We recommend using a diesel fuel with a sulphur content of less than 0.1 %.

When using a diesel fuel with a high sulphur content of 0.5 % to 1.0 % the oil change intervals must be halved.

Fuels with a sulphur content of more than 1.0 % are not permitted.

In order to fulfil national emission regulations one must strictly use the legally required fuels (e.g. sulphur content).

For engines used in EPA areas, the use of diesel fuels with ultra-low sulphur content is mandatory (ASTM D975 Grade-No. 1-D S15 and 2-D S15).

*(EPA: United States Environmental Protection Agency)*

The recommended Cetan index number is 45. A Cetan index number higher than 50 should preferably be used, especially at ambient temperatures below -20 °C (-4 °F) and when working at altitudes of more than 1500 m (4921 ft).

The following fuel specifications are recommended:

- EN 590
- ASTM D975 Grade-No. 1-D and 2-D

#### 8.3.2.2 Winter fuel

For winter operation use only winter diesel fuel, to avoid clogging because of paraffin separation.

At very low temperatures disturbing paraffin separation can also be expected when using winter diesel fuel.

Diesel fuels suitable for temperatures down to -44 °C (-47 °F) are available for Arctic climates.



#### **NOTICE!**

##### **Danger of engine damage!**

- The admixture of petroleum and the addition of “flow enhancing additives” (fuel additives) is not permitted.

#### 8.3.2.3 Storage

Even traces of zinc, lead and copper can cause deposits in the injection nozzles, especially in modern Common-Rail injection systems.

Zinc and lead coatings in refuelling systems and fuel lines are not permitted.

Copper containing materials (copper lines, brass items) should be avoided, because they can cause catalytic reactions in the fuel with subsequent depositing in the injection system.

### 8.3.3 Coolant

Always use a mixture of anti-freeze agent and clean, dehardened water with a mixing ratio of 1:1.

Under particularly extreme temperature conditions you should consult our customer service concerning the anti-freeze agent to be used.

There are various types of anti-freeze agents available. For this engine you should use ethylene glycol.

Before filling in the coolant mixed with anti-freeze agent the radiator must be flushed with clean water. This procedure should be repeated two to three times to clean the inside of radiator and engine block.



#### **NOTICE!**

#### **Danger of engine damage!**

- Do not mix different coolants and additives of any other kind.

Mixing the coolant:

- Prepare a mixture of 50% anti-freeze agent and 50% low mineral, clean water.
- Stir well before filling it into the radiator.
- The method of mixing water and anti-freeze depends on the brand of the anti-freeze agent (see standard SAE J1034 and also standard SAE J814c).

Add anti-freeze agent:

- If the coolant level drops because of evaporation, only clean water is to be used for topping up.
- In case of leakages you must always fill in anti-freeze agents of the same brand and the same mixing ratio.

Do not use any radiator cleaning agent after the anti-freeze agent has been mixed in. The anti-freeze agent also contains a corrosion protection agent. If this mixes with cleaning agent it may cause the development of sludge, which could damage the cooling system.

Anti-freeze concentration	Freezing point
50 %	-37 °C (-35 °F)

### 8.3.4 Oil for exciter shaft housing

Use only engine oils according to the following specifications:

- API CI-4 or higher quality

Avoid mixing engine oils.



#### **NOTICE!**

##### **Components may get damaged!**

- Do not use low-ash engine oils for the exciter shaft housing.

### 8.3.5 Hydraulic oil

#### 8.3.5.1 Mineral oil based hydraulic oil

The hydraulic system is operated with hydraulic oil HV 46 (ISO) with a kinematic viscosity of 46 mm<sup>2</sup>/s at 40 °C (104 °F) and 8 mm<sup>2</sup>/s at 100 °C (212 °F).

When refilling or changing oil, use only hydraulic oil type HVLV according to DIN 51524, part 3, or hydraulic oil type HV according to ISO 6743/4.

The viscosity index must be at least 150 (observe information of manufacturer).

#### 8.3.5.2 Bio-degradable hydraulic oil

The hydraulic system can also be operated with a synthetic ester based biodegradable hydraulic oil.

The biodegradable hydraulic oil Panolin HLP Synth. 46 or Plantohyd 46 S meets all the requirements of a mineral oil based hydraulic oil according to DIN 51524.

In hydraulic systems filled with biodegradable hydraulic oil, always use the same oil to top up and do not mix oil types.

When changing from mineral oil based hydraulic oil to an ester based biologically degradable hydraulic oil, you should consult the lubrication oil service of the oil manufacturer, or our customer service for details.



#### **NOTICE!**

##### **Danger of damage to the hydraulic system!**

- After the changeover check the hydraulic oil filters increasingly for contamination.
- Have regular oil analyses performed regarding the water content and mineral oil.
- Replace the hydraulic oil filter at the latest after 500 operating hours.

## 8.4 List of fuels and lubricants

Assembly group	Fuel or lubricant		Spare parts number	Filling quantity
	Summer	Winter		Observe the level mark!
Engine oil	SAE 10W-40 Specification: ↗ <i>Chapter 8.3.1 'Engine oil' on page 109</i> In North America, use only low-ash engine oils!		009 920 06 20 l	4.7 l (1.2 gal us)
	SAE 10W-30			
	SAE 15W-40			
	SAE 30			
Fuel	Diesel	Winter diesel fuel		24 l (6 gal us)
	Specification: ↗ <i>Chapter 8.3.2 'Fuel' on page 110</i>			
Coolant	Mixture of water and anti-freeze agent Specification: ↗ <i>Chapter 8.3.3 'Coolant' on page 111</i>		009 940 03 20 l	4.0 l (1.1 gal us)
Hydraulic system	Hydraulic oil (ISO), HVLP 46 Specification: ↗ <i>Chapter 8.3.5.1 'Mineral oil based hydraulic oil' on page 112</i>		009 930 09 20 l	17 l (4.5 gal us)
	or ester based biodegradable hydraulic oil Specification: ↗ <i>Chapter 8.3.5.2 'Bio-degradable hydraulic oil' on page 112</i>			
Exciter shaft housing	Engine oil SAE 15W-40 Specification: ↗ <i>Chapter 8.3.4 'Oil for exciter shaft housing' on page 112</i>			2 x 1.7 l (0.5 gal us)

### 8.5 Running-in instructions

#### 8.5.1 General

The following maintenance work must be performed when running in new machines or overhauled engines.



#### **NOTICE!**

##### **Danger of engine damage!**

- Up to approx. 250 operating hours check the engine oil level twice every day.

Depending on the load the engine is subjected to, the oil consumption will drop to the normal level after approx. 100 to 250 operating hours.

#### 8.5.2 After 50 operating hours

1. Change the engine oil and oil filter cartridge ↪ *Chapter 8.8.1 'Change engine oil and oil filter cartridge' on page 120.*
2. Check the engine for leaks.
3. Tighten all bolted connections on air intake, exhaust, oil sump and engine mounts.
4. Retighten the bolted connections on the machine.
5. Check the central screw of the drive hubs; retighten if necessary ↪ *Chapter 8.13.4 'Checking the central screw of the drive hub' on page 143.*

#### 8.5.3 After 250 operating hours

1. Change the engine oil and oil filter cartridge ↪ *Chapter 8.8.1 'Change engine oil and oil filter cartridge' on page 120.*
2. Check the central screw of the drive hubs; retighten if necessary ↪ *Chapter 8.13.4 'Checking the central screw of the drive hub' on page 143.*

## 8.6 Maintenance Table

No.	Maintenance works	Page
<b>Weekly</b>		
8.7.1	<i>Air filter maintenance</i>	116
8.7.2	<i>Checking and cleaning the water separator</i>	119
<b>Every 250 operating hours/annually</b>		
8.8.1	<i>Change engine oil and oil filter cartridge</i>	120
8.8.2	<i>Checking, tensioning the V-belt</i>	121
8.8.3	<i>Replacing the air filter</i>	122
8.8.4	<i>Check the air intake lines</i>	123
8.8.5	<i>Changing the oil in the exciter housing</i>	124
8.8.6	<i>Replacing the fuel filter; bleeding the fuel system</i>	126
8.8.7	<i>Draining the fuel tank sludge</i>	128
8.8.8	<i>Checking radiator hoses and hose clamps</i>	128
8.8.9	<i>Servicing the battery; checking the main battery shutoff</i>	129
<b>Every 500 operating hours</b>		
8.9.1	<i>Replacing the V-belt</i>	131
<b>Every 1000 operating hours</b>		
8.10.1	<i>Adjusting the valve clearance</i>	132
<b>Every 2000 operating hours</b>		
8.11.1	<i>Changing the hydraulic oil and filter</i>	135
8.11.2	<i>Changing the coolant</i>	137
8.11.3	<i>Replacing hoses</i>	139
8.11.4	<i>Check the injection valves</i>	139
<b>Every 3000 operating hours</b>		
8.12.1	<i>Checking the fuel injection pump</i>	140
<b>As required</b>		
8.13.1	<i>Checking/adjusting the scrapers</i>	141
8.13.2	<i>Cleaning the radiator module</i>	141
8.13.3	<i>Cleaning the machine</i>	142
8.13.4	<i>Checking the central screw of the drive hub</i>	143
8.13.5	<i>Cleaning the drum drive / drums</i>	144
8.13.6	<i>Measures prior to extended shut-down period</i>	146

### 8.7 Weekly

#### 8.7.1 Air filter maintenance

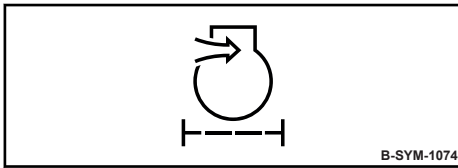

Fig. 131



#### NOTICE!

##### Danger of engine damage!

- Do not start the engine after having removed the air filter.
- If necessary, the air filter may be cleaned up to six times.
- Cleaning does not make sense if the air filter element is covered with a sooty deposit.
- Do not use gasoline or hot fluids to clean the filter element.
- After cleaning, the air filter must be inspected for damage using a torch.
- Do not continue to use a damaged air filter element. If in doubt use a new air filter.

Protective equipment: ■ Working clothes  
■ Safety shoes  
■ Protective gloves  
■ Safety goggles

1. Park the machine safely ↪ *Chapter 6.6 'Parking the machine in secured condition' on page 93.*
2. Allow the engine to cool down.
3. Check the air filter maintenance indicator.

#### Checking the maintenance indicator

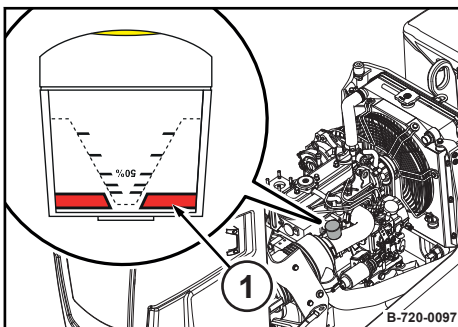

Fig. 132

If the yellow pin has reached the red area (1) service the air filter.



### Air filter maintenance

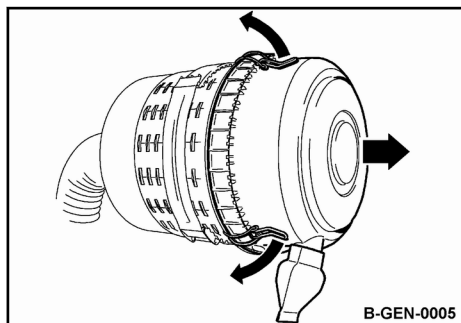

Fig. 133

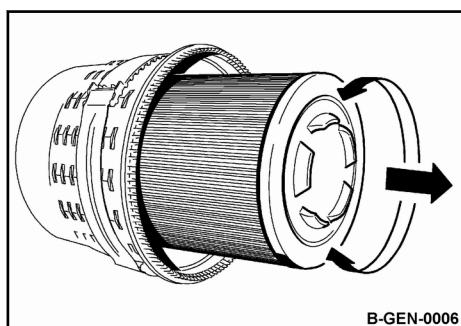

Fig. 134

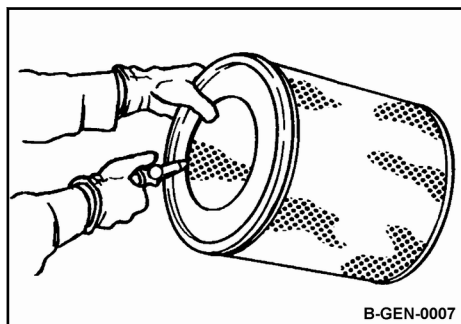

Fig. 135

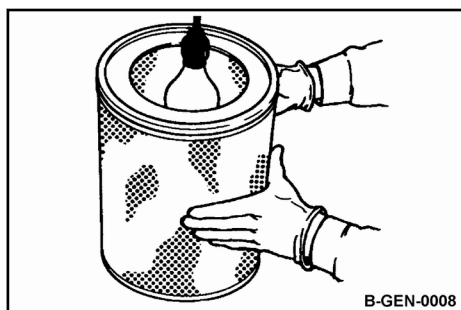

Fig. 136

4. Release the snap bow and take off the cover.
5. Clean the cover and dust discharge valve.
6. Pull out the air filter with a slight turning motion.
7. Thoroughly clean the filter housing and sealing faces.
8. Clean the inside of the drain pipe in the filter housing thoroughly.



#### CAUTION!

**Danger of eye injuries caused by particles flying around!**

- Wear your personal protective equipment (safety gloves, protective working clothes, goggles).

9. Blow the air filter out with dry compressed air (max. 2.1 bar (30 psi)) from inside to outside by moving the gun up and down inside the element, until it is free of dust.
10. Examine the air filter with a torch for cracks and holes in the paper bellows.
11. Replace the air filter if it is damaged.

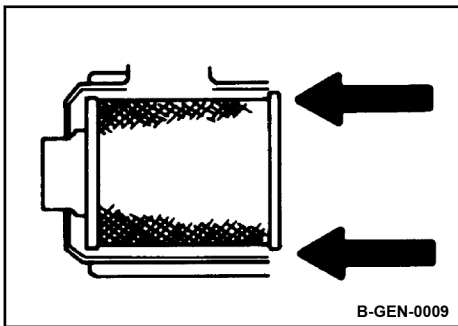

Fig. 137

### Resetting the maintenance indicator

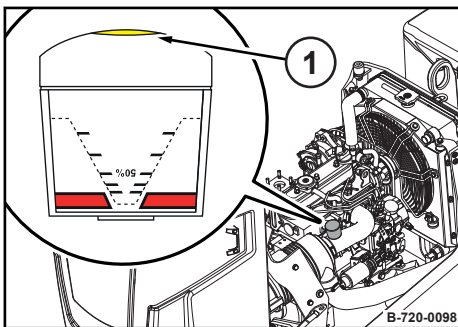

Fig. 138

12. Slide the air filter carefully into the housing.



#### NOTICE!

#### Danger of engine damage!

- The dust discharge valve must point vertically downwards.
- Make sure that the cover locks engage correctly.

13. Reinstall the cover.

14. After maintenance has been completed, press the button (1) on the maintenance indicator.

⇒ The maintenance indicator is reset.

## 8.7.2 Checking and cleaning the water separator

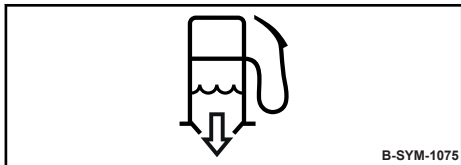

Fig. 139



*The service intervals for the water separator depend on the water content in the fuel and can therefore not be determined precisely.*

*After taking the engine into operation you should check for signs of water and dirt initially every day.*

Protective equipment: ■ Working clothes  
 ■ Safety shoes  
 ■ Protective gloves

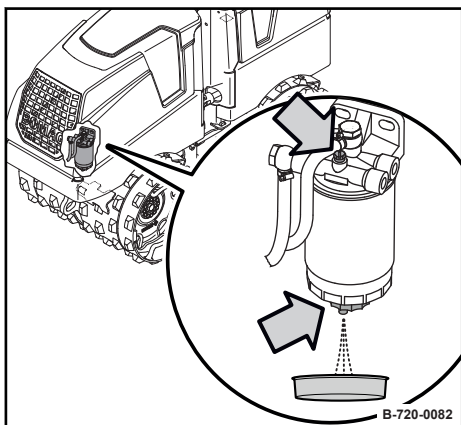

Fig. 140

1. Park the machine safely ↗ Chapter 6.6 'Parking the machine in secured condition' on page 93.
2. Loosen the bleed screw by a few turns.
3. Loosen the drain plug and drain the fluid until pure diesel fuel starts to run out.
4. Collect escaping fluids.
5. Screw the drain plug back in tightly. Check for leaks; if necessary, use a new seal ring.
6. Bleed the fuel system ↗ Chapter 8.8.6.2 'Bleeding the fuel system' on page 127.
7. Retighten the bleed screw. Check for leaks; if necessary, use a new seal ring.
8. Dispose of collected fluid in line with environmental regulations.

## 8.8 Every 250 operating hours/annually

### 8.8.1 Change engine oil and oil filter cartridge



Perform this maintenance work at the latest after one year.



#### NOTICE!

##### Danger of engine damage!

- Change the oil only with the engine at operating temperature.
- Use only oil of the permitted specification ↪ Chapter 8.3.1 'Engine oil' on page 109.
- Filling quantity: ↪ Chapter 8.4 'List of fuels and lubricants' on page 113

Protective equipment: ■ Working clothes  
■ Safety shoes  
■ Protective gloves

1. Park the machine safely ↪ Chapter 6.6 'Parking the machine in secured condition' on page 93.

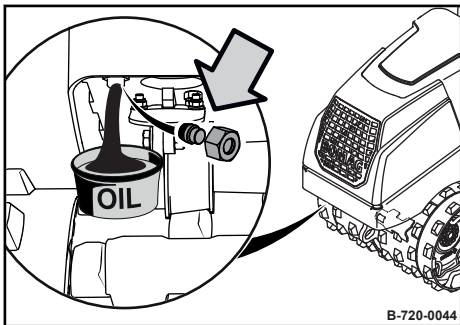

Fig. 141

- 2.



#### WARNING!

##### Danger of burning on hot components!

- Wear your personal protective equipment (protective gloves, protective clothing).
- Avoid touching hot components.

Unscrew the drain plug and collect any escaping oil.

3. Screw the drain plug back in tightly.

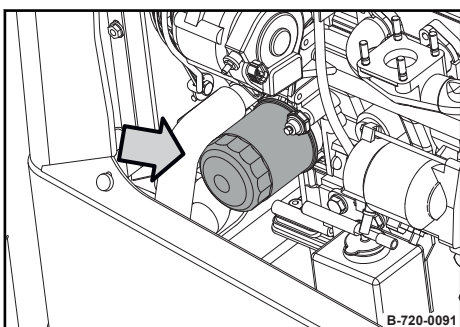

Fig. 142

4. Thoroughly clean the outside of the oil filter cartridge.
5. Unscrew the oil filter cartridge using an appropriate strap wrench.
6. Remove any dirt from the sealing face of the filter carrier.
7. Thinly apply oil to the rubber seal of the new oil filter cartridge.
8. Screw on the oil filter cartridge and tighten by hand.

## Maintenance – Every 250 operating hours/annually

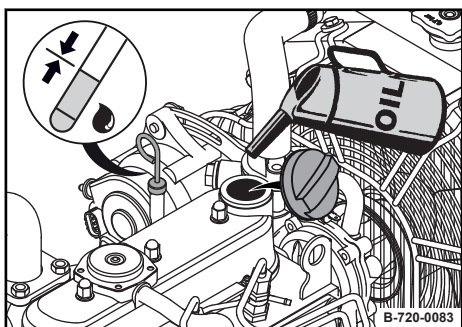

Fig. 143

9. Clean the area around the filling port and the oil dipstick.
10. Remove the cap and fill with fresh engine oil.
11. Close the cap.
12. After a short test run, check the oil level on the oil dipstick; if necessary, top up to the “MAX” mark.
13. Check the oil filter cartridge and drain plug for leaks.
14. Dispose of the oil and filters in line with environmental regulations.

### 8.8.2 Checking, tensioning the V-belt

#### 8.8.2.1 Checking the V-belt

Protective equipment: ■ Working clothes  
■ Protective gloves

1. Park the machine in secured condition ↪ *Chapter 6.6 'Parking the machine in secured condition' on page 93.*
2. Allow the engine to cool down.
3. Check the entire circumference of the V-belt for damage and cracks.
4. Replace a damaged or cracked V-belt ↪ *Chapter 8.9.1 'Replacing the V-belt' on page 131.*
5. Check with thumb pressure whether the V-belt can be depressed more than 7 to 9 mm (0.28 – 0.35 inch) between the V-belt pulleys, retighten if necessary.

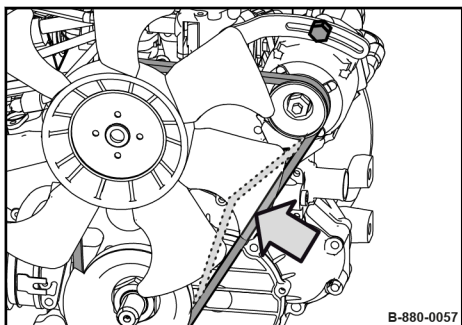

Fig. 144

#### 8.8.2.2 Tightening the V-belt

Protective equipment: ■ Working clothes  
■ Protective gloves

1. Loosen the tensioning screw (1) and the screw (2) on the generator.
2. Press the generator towards the outside using a lever, until the correct V-belt tension is reached.
3. Retighten clamping screw (1) and screw (2).

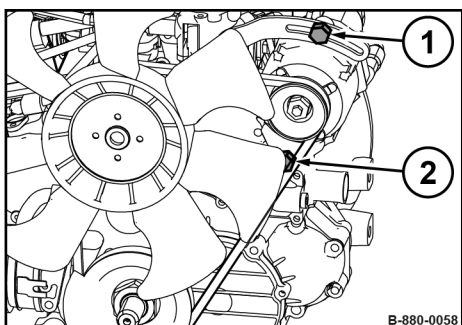

Fig. 145

### 8.8.3 Replacing the air filter



Perform this maintenance work at the latest after one year.

Protective equipment: ■ Working clothes  
■ Safety shoes  
■ Protective gloves

1. Park the machine safely ↪ Chapter 6.6 'Parking the machine in secured condition' on page 93.
2. Release the snap bow and take off the cover.
3. Clean the cover and dust discharge valve.

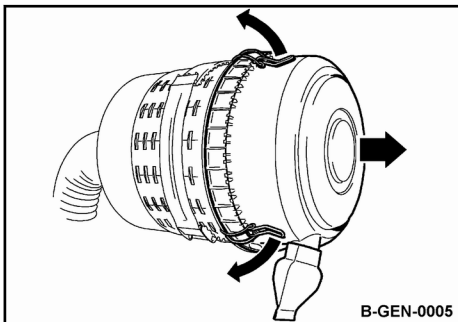

Fig. 146

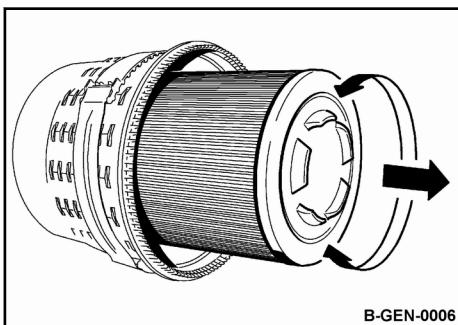

Fig. 147

4. Pull out the air filter with a slight turning motion and replace.
5. Thoroughly clean the filter housing and sealing faces.
6. Clean the inside of the drain pipe in the filter housing thoroughly.

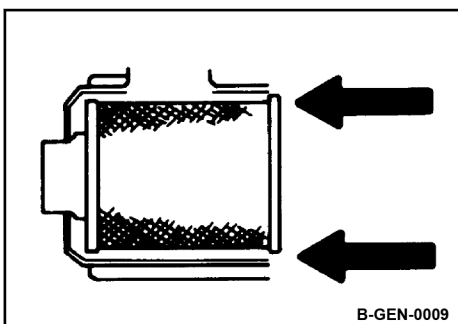

Fig. 148

7. Slide the new air filter carefully into the housing.



#### NOTICE!

#### Danger of engine damage!

- The dust discharge valve must point vertically downwards.
- Make sure that the cover locks engage correctly.

8. Reinstall the cover.

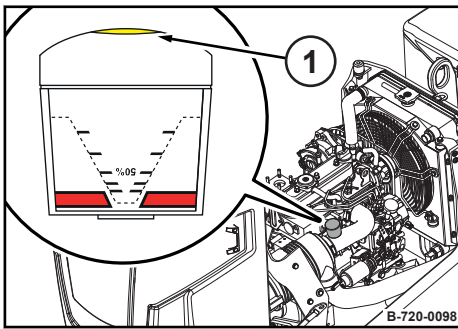

Fig. 149

9. Press the button (1) on the maintenance indicator.  
⇒ The maintenance indicator is reset.

### 8.8.4 Check the air intake lines

Protective equipment: ■ Working clothes  
■ Safety shoes  
■ Protective gloves

1. Park the machine safely ↪ Chapter 6.6 'Parking the machine in secured condition' on page 93.
2. Allow the engine to cool down.
3. Check the condition and tight fit of all air intake lines and hose clamps.
4. If necessary, replace any damaged air intake lines or hose clamps.

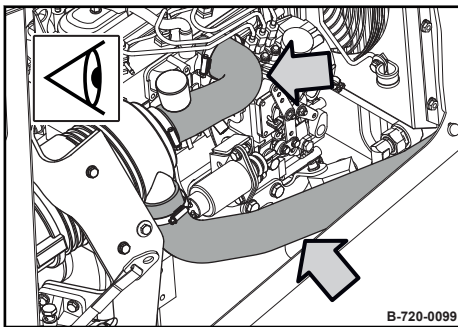

Fig. 150

### 8.8.5 Changing the oil in the exciter housing

Loads may only be lifted by an expert/qualified person.

Do not use lifting points that are damaged or impaired in any way.

Only use lifting and lashing tackle with sufficient load bearing capacity for the weight to be loaded.

Always use appropriate lifting tackle at the lifting points.

Use lifting tackle only in the specified loading direction.

Lifting tackle must not be damaged by machine parts.

When lifting the machine, make sure the load does not move in an uncontrolled way. If necessary, hold the load steady with guide ropes.



*Perform this maintenance work at the latest after one year.*



#### **NOTICE!**

##### **Components may get damaged!**

- Only change the oil at operating temperature.
- Only use oil of the permitted specification  
↳ Chapter 8.3.4 'Oil for exciter shaft housing' on page 112.
- Filling quantity: ↳ Chapter 8.4 'List of fuels and lubricants' on page 113
- Do not use low-ash engine oils for the exciter shaft housing.

Protective equipment: ■ Working clothes  
■ Safety shoes  
■ Protective gloves

1. Park the machine safely ↳ Chapter 6.6 'Parking the machine in secured condition' on page 93.
2. Engage the articulation lock ↳ Chapter 8.2.2.1 'Engaging the articulation lock' on page 107.
3. Attach lifting tackle to the front lashing point.
4. Lift the machine at the front and support the front drum.
5. Secure the rear drum with a wheel chock.

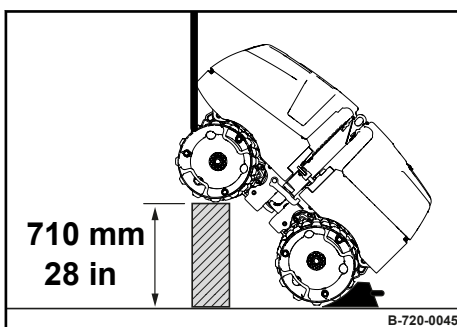

Fig. 151



## Maintenance – Every 250 operating hours/annually

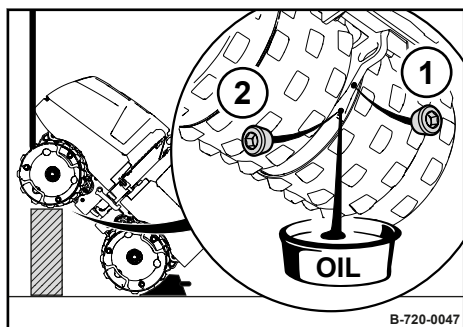

Fig. 152

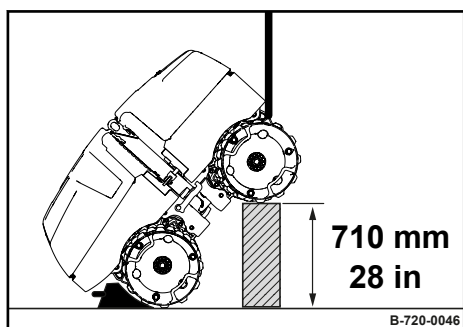

Fig. 153

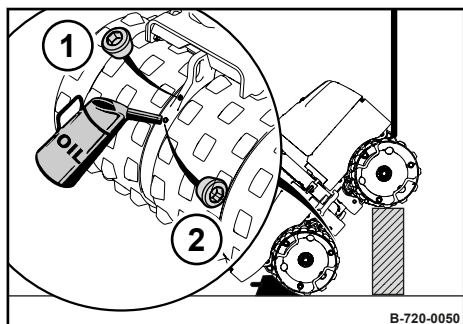

Fig. 154

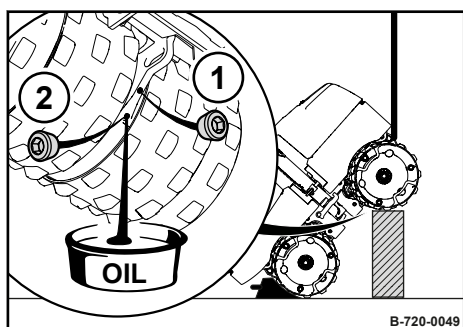

Fig. 155

6.



### WARNING!

#### Danger of burning on hot components!

- Wear your personal protective equipment (protective gloves, protective clothing).
- Avoid touching hot components.

Clean and remove the bleed screw (1) and drain plug (2) from the front drum.

7. Drain off and collect all oil.

8. Lower the machine and attach lifting tackle to the rear lashing point.

9. Lift the machine at the rear and support the rear drum.

10. Secure the front drum with a wheel chock.

11. Fill the front drum with oil via the drain opening.

12. Screw the bleed screw (1) and drain plug (2) back in tightly.

13.



### WARNING!

#### Danger of burning on hot components!

- Wear your personal protective equipment (protective gloves, protective clothing).
- Avoid touching hot components.

Clean and remove the bleed screw (1) and drain plug (2) from the rear drum.

14. Drain off and collect all oil.

15. Lift the machine at the front again, support the front drum securely, and secure the rear drum with a wheel chock.

## Maintenance – Every 250 operating hours/annually

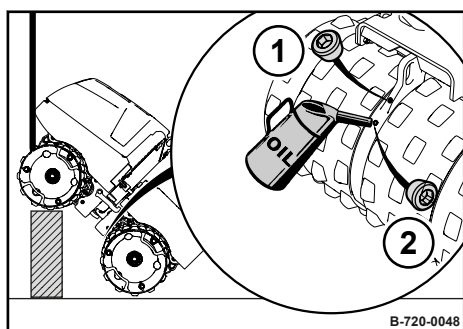

Fig. 156

16. Fill the rear drum with oil via the drain opening.
17. Screw the bleed screw (1) and drain plug (2) back in tightly.
18. Lower the machine.
19. Dispose of oil in line with environmental regulations.

### 8.8.6 Replacing the fuel filter; bleeding the fuel system

#### 8.8.6.1 Replacing the fuel filter



#### NOTICE!

##### Danger of engine damage!

- Ensure strict cleanliness! Thoroughly clean the area around the fuel filters.
- Air in the fuel system causes irregular running of the engine, a drop in engine power, stalls the engine and makes starting impossible.

Protective equipment: ■ Working clothes  
■ Safety shoes  
■ Protective gloves

1. Park the machine safely ↗ *Chapter 6.6 'Parking the machine in secured condition' on page 93.*
2. Remove the bolts and washers (2).
3. Open the central electrics (1).

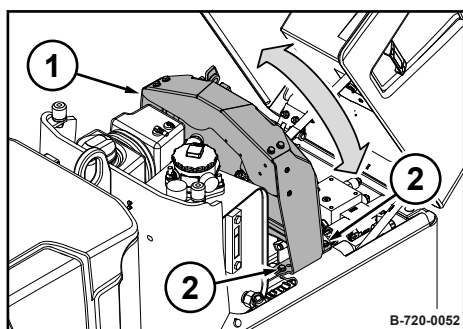

Fig. 157

## Maintenance – Every 250 operating hours/annually

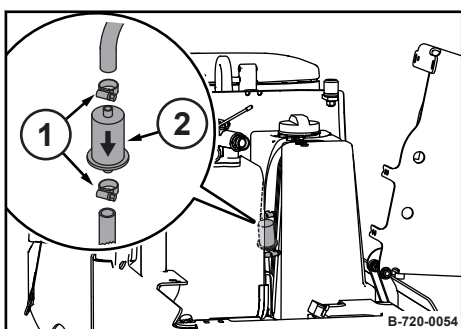

Fig. 158

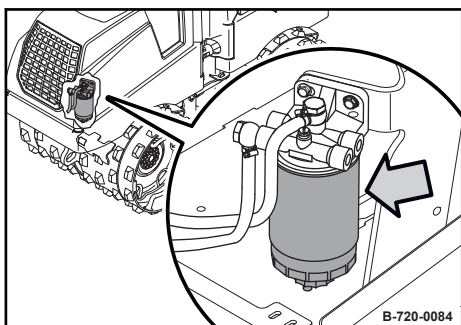

Fig. 159

4. Loosen the hose clamps (1) on the fuel pre-filter (2).
5. Pull the fuel lines off the fuel pre-filter.
6. Install the new fuel pre-filter and observe the flow direction (arrow).
7. Reconnect the fuel hoses with hose clamps.
8. Shut the central electrics and screw it back down.

9. Loosen the fuel filter using a suitable strap wrench and remove.
10. Remove any dirt from the sealing face of the filter carrier.
- 11.



### NOTICE!

#### Danger of engine damage!

- Never fill filters beforehand, to avoid the entry of dirt into the clean side.

Thinly apply oil to the rubber seal on the new fuel filter.

12. Screw on the new filter cartridge by hand until the seal is in contact, then tighten by hand.
13. Dispose of fuel and fuel filters in line with environmental regulations.
14. Bleed the fuel system ↪ *Chapter 8.8.6.2 'Bleeding the fuel system' on page 127.*

### 8.8.6.2 Bleeding the fuel system

- Protective equipment:
- Working clothes
  - Safety shoes
  - Protective gloves

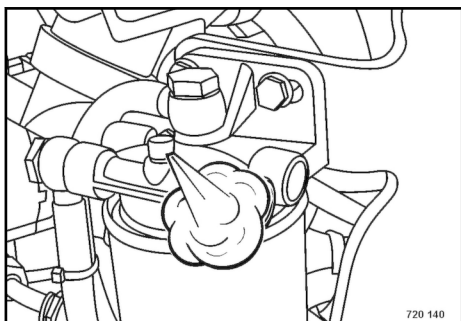

Fig. 160

1. Loosen the bleed screw on the fuel filter 2 to 3 turns.

## Maintenance – Every 250 operating hours/annually

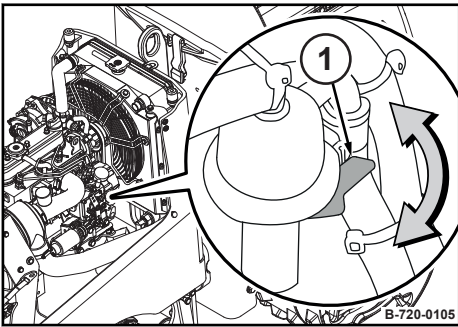

Fig. 161

2. Operate the hand lever (1) on the fuel lift pump until fuel flows out of the loosened bleed screw without air bubbles.
3. Collect the escaping fuel.
4. Tighten the bleeding screw.
5. Start the engine and run it for 5 minutes at idle speed.
6. Check the fuel pre-filter for leaks.
7. Dispose of collected fuel in line with environmental regulations.

### 8.8.7 Draining the fuel tank sludge

**i** The filling level of the fuel tank should not exceed 5.0 l (1.3 gal US) for draining purposes.

Protective equipment: ■ Working clothes  
■ Safety shoes  
■ Protective gloves

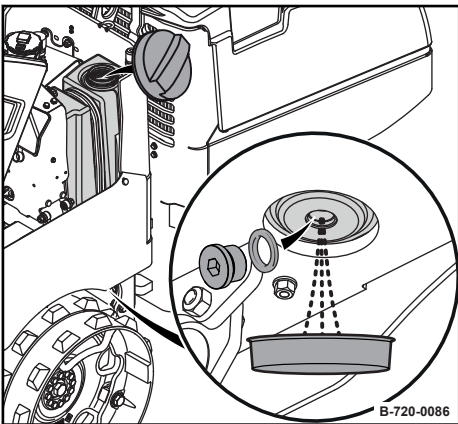

Fig. 162

1. Park the machine safely ↪ Chapter 6.6 'Parking the machine in secured condition' on page 93.
2. Clean the area around the filler opening and remove the cap.
3. Unscrew the drain plug and drain off approx. 5.0 l (1.3 gal US) of fuel.
4. Collect the escaping fuel.
5. Screw the drain plug back on tightly.
6. Fill the fuel tank with clean fuel.
7. Dispose of collected fuel in line with environmental regulations.

### 8.8.8 Checking radiator hoses and hose clamps

Protective equipment: ■ Working clothes  
■ Protective gloves

1. Park the machine in secured condition ↪ Chapter 6.6 'Parking the machine in secured condition' on page 93.
2. Allow the engine to cool down.
3. Check the condition and tight fit of all fuel lines and hose clamps.

## Maintenance – Every 250 operating hours/annually

4. If fuel lines or hose clamps are found to be damaged, the corresponding parts must be immediately repaired or replaced by authorized service personnel.



### NOTICE!

#### Danger of engine damage!

- After work on the fuel system bleed the system, perform a test run and check for leaks.

## 8.8.9 Servicing the battery; checking the main battery shutoff

### 8.8.9.1 Battery service



*Maintenance free batteries also need care. Maintenance free only means that the fluid level does not need to be checked.*

*Every battery has a self-discharge, which may, if not checked occasionally, even cause damage to the battery as a result of exhaustive discharge.*

*Exhausted batteries (batteries with formation of sulphate on the plates) are not covered under warranty!*

- Protective equipment:
- Working clothes
  - Safety shoes
  - Protective gloves
  - Safety goggles

1. Park the machine safely ☞ *Chapter 6.6 'Parking the machine in secured condition' on page 93.*
2. Remove the battery and clean the battery compartment.
3. Clean the outside of the battery.
4. Clean the battery poles and terminals and grease them with pole grease (Vaseline).
5. Install the battery and check the battery fastening.
6. Check the condition of the vibration insulation mats; replace if necessary.
7. On serviceable batteries check the acid level; if necessary, top up to the filling mark with distilled water.

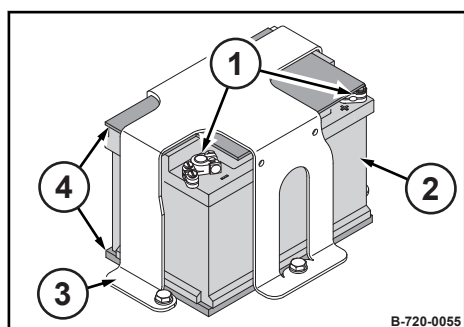
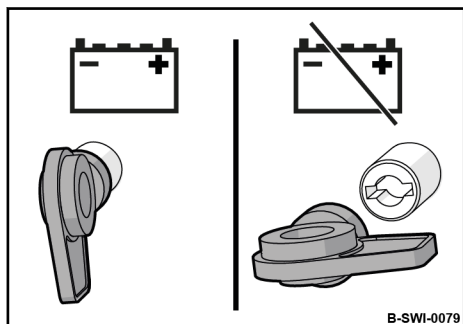

Fig. 163

- 1 Terminal
- 2 Battery
- 3 Battery fastening
- 4 Vibration insulation mat

**8.8.9.2 Checking the main battery shutoff**



*Fig. 164*

1. Turn the main battery switch counter-clockwise and pull it out.
2. Check by turning the ignition key, whether the battery is disconnected from the electric system of the machine.

### 8.9 Every 500 operating hours

#### 8.9.1 Replacing the V-belt

**i** Perform this maintenance work at the latest after two years.

Protective equipment: ■ Working clothes  
■ Safety shoes  
■ Protective gloves

1. Park the machine safely ↗ *Chapter 6.6 'Parking the machine in secured condition' on page 93.*
2. Allow the engine to cool down.
3. Loosen the tensioning screw (1) and screw (2) on the generator.
4. Press the generator inwards, and release and remove the V-belt.
5. Install the new V-belt.
6. Tension the V-belt to the specified value ↗ *Chapter 8.8.2 'Checking, tensioning the V-belt' on page 121.*
7. Retighten the clamping screw and screw.

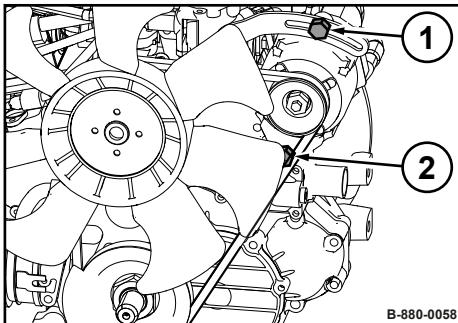

Fig. 165

## Maintenance – Every 1000 operating hours

### 8.10 Every 1000 operating hours

#### 8.10.1 Adjusting the valve clearance



#### NOTICE!

#### Danger of engine damage!

We recommend to have this work carried out by trained personnel or our after sales service.

- Before checking the valve clearance let the engine cool down for at least 30 minutes. The engine oil temperature must be below 80 °C (176 °F).

#### Valve clearance

Intake/exhaust valve	0.15 mm to 0.19 mm (0.006 in to 0.007 in)
----------------------	--

Protective equipment:

- Working clothes
- Safety shoes
- Protective gloves

1. Park the machine safely ↪ *Chapter 6.6 'Parking the machine in secured condition' on page 93.*
2. Allow the engine to cool down.
3. Remove the valve cover.

#### Preparations

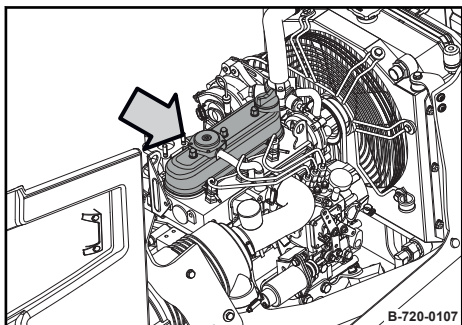

Fig. 166



### Checking the valve clearance

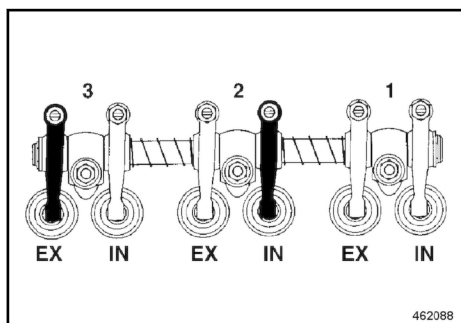

Fig. 167

IN Intake valve  
EX Exhaust valve

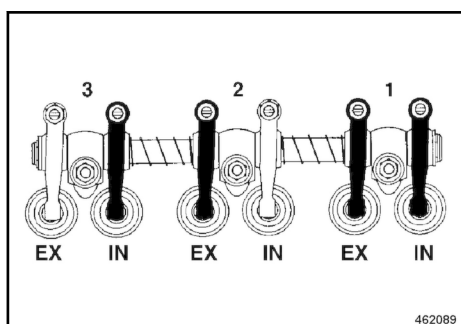

Fig. 168

IN Intake valve  
EX Exhaust valve

### Adjusting the valve clearance

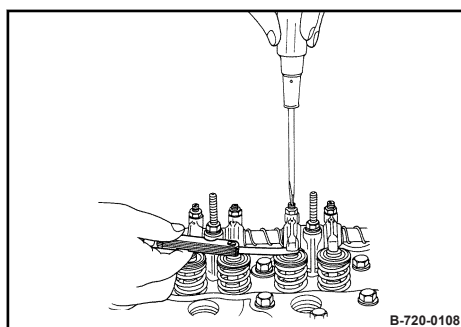

Fig. 169

- Turn the crankshaft using a V-belt until both valves on cylinder 1 overlap.



*Cylinder 1 is on the fan side.*

- Check the valve clearance on the valves marked black; adjust if necessary.
  - ⇒ The feeler gauge must fit through the gap with little resistance.
- Turn the crankshaft one full turn (360 °) more using the V-belt.
- Check the valve clearance on the valves marked black using a feeler gauge; adjust if necessary.
  - ⇒ The feeler gauge must fit through the gap with little resistance.
- Loosen the counter nut on the rocker arm.
- Adjust the valve clearance using the adjustment screw.
- Tighten the counter nut.

## Maintenance – Every 1000 operating hours

### Concluding work

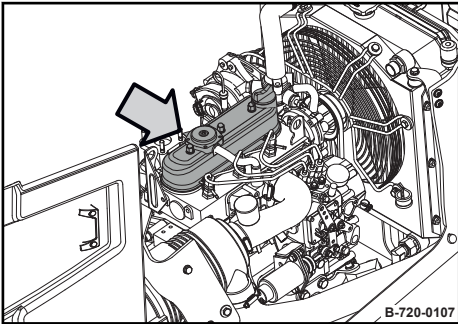

Fig. 170

11. Install the valve cover with a new seal.
12. After a short test run check the valve cover for leaks.

### 8.11 Every 2000 operating hours

#### 8.11.1 Changing the hydraulic oil and filter

**i** Perform this maintenance work at the latest after two years.

The hydraulic oil and filter also requires changing after major repairs in the hydraulic system.

Always replace the hydraulic oil filter after each hydraulic oil change.

Do not start the engine after draining off the hydraulic oil.

Do not use any detergents to clean the system.

Use only lint-free cleaning cloths for cleaning.

When changing over from mineral oil-based hydraulic oil to an ester-based, biologically degradable hydraulic oil, consult the lubrication service of the respective oil manufacturer, or our Customer Service for details.



#### NOTICE!

##### Risk of damage!

- Perform the oil change when the hydraulic oil is warm.
- Use only hydraulic oil of the permitted specification ↪ Chapter 8.3.5 'Hydraulic oil' on page 112.
- Filling quantity: ↪ Chapter 8.4 'List of fuels and lubricants' on page 113.

Protective equipment: ■ Working clothes  
■ Safety shoes  
■ Protective gloves

1. Park the machine safely ↪ Chapter 6.6 'Parking the machine in secured condition' on page 93.

2.



#### WARNING!

##### Danger of burning on hot components!

- Wear your personal protective equipment (protective gloves, protective clothing).
- Avoid touching hot components.

Unscrew the drain plug.

3. Drain off and collect all hydraulic oil.

4. Screw the drain plug back in.

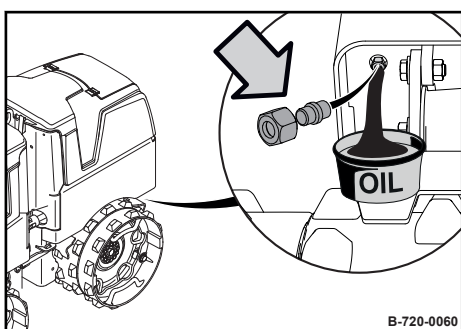

Fig. 171

## Maintenance – Every 2000 operating hours

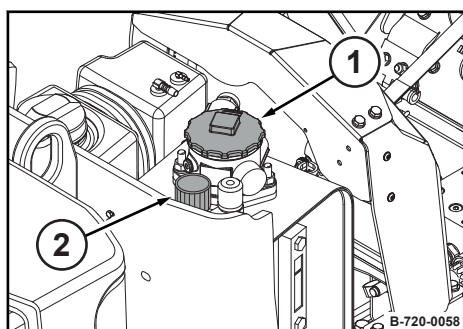

Fig. 172

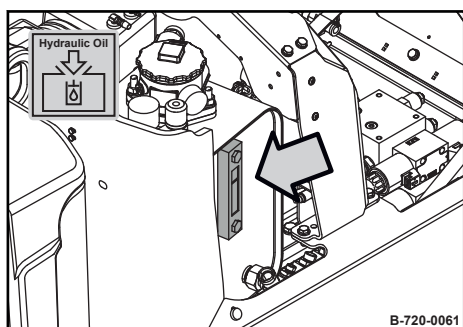

Fig. 173

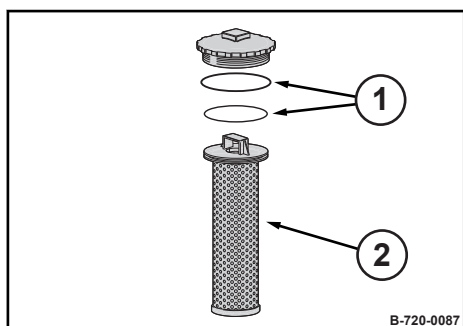

Fig. 174

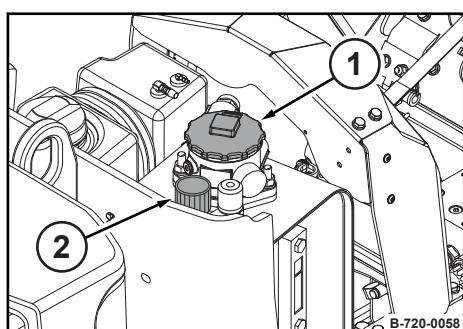

Fig. 175

5. Clean the area round the hydraulic oil tank, cap (1) and breather filter (2).
6. Unscrew the cap and remove with filter element.
- 7.



*We recommend to use our filling and filtering unit with fine filter to fill the system. This ensures finest filtration of the hydraulic oil, prolongs the lifetime of the hydraulic oil filter and protects the hydraulic system.*

Fill up with fresh hydraulic oil.

8. Check the oil level in the inspection glass.
  - ⇒ **Nominal value:** Approx. 3 cm (1.2 in) below the top edge of the inspection glass

9. Insert a new filter element (2) and new O-rings (1).

10. Screw the cap (1) back on.
11. Replace the breather filter (2).
12. After the test run, check the filters for leaks.
13. Dispose of the hydraulic oil and filter in line with environmental regulations.

### 8.11.2 Changing the coolant



Perform this maintenance work at the latest after two years.

Do not start the engine after draining off the coolant.

In case of lubrication oil entering into the cooling system or a suspicious turbidity caused by corrosion residues or other suspended matter, the coolant must be drained off and the complete cooling system needs to be cleaned.

Oil can damage the sealing materials used in the cooling system.

If oil has entered, you must add a cleansing agent in order to remove any residues from the system. Follow the instructions of the manufacturer! If in doubt, consult your Customer Service or the engine manufacturer.

When changing the coolant without any signs of contamination, cleaning of the cooling system is not necessary.



#### NOTICE!

##### Danger of engine damage!

- Use only coolant of the permitted specification  
↳ Chapter 8.3.3 'Coolant' on page 111.
- Do not mix different coolants and additives of any other kind.
- Filling quantity: ↳ Chapter 8.4 'List of fuels and lubricants' on page 113

- Protective equipment:
- Working clothes
  - Safety shoes
  - Protective gloves
  - Safety goggles

1. Park the machine safely ↳ Chapter 6.6 'Parking the machine in secured condition' on page 93.
2. Allow the engine to cool down.
3. Unscrew the cap.

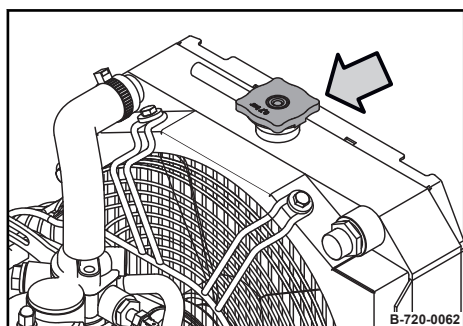

Fig. 176

## Maintenance – Every 2000 operating hours

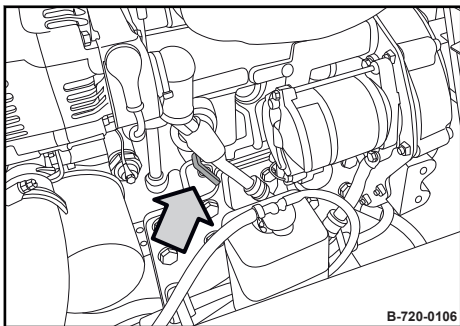

Fig. 177

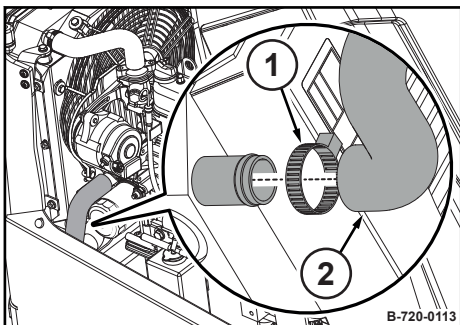

Fig. 178

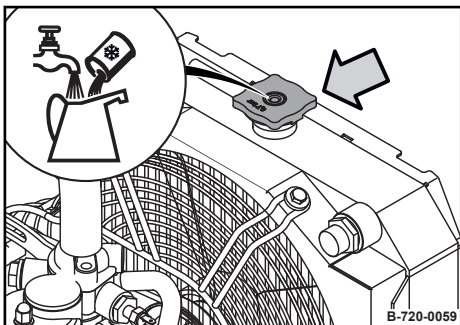

Fig. 179

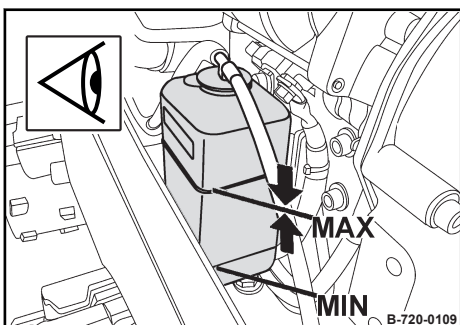

Fig. 180

4. Open the drain valve on the engine.
5. Loosen the hose clamp (1) and pull the hose (2) off the radiator.
6. Drain off the coolant completely and collect it.
7. Close the drain valve again.
8. Push the hose back on again and tighten the hose clamp.
9. Fill with coolant until the level reaches the bottom edge of the filler neck.
10. Check the coolant level in the compensation tank.
  - ⇒ The coolant level must be between the “MIN” and “MAX” marks.
11. If necessary, fill with coolant up to the “MAX” mark.
12. Screw the filler cap back on again.
13. Start the engine and run to operating temperature.
14. Let the engine cool down and check the coolant level again; if necessary, top up in the compensation tank.
15. Dispose of coolant in line with environmental regulations.

### 8.11.3 Replacing hoses

This work must only be performed by authorized service personnel.



*Perform this maintenance work at the latest after two years.*

The following hoses need to be renewed:

- fuel hoses,
- air intake hoses.

### 8.11.4 Check the injection valves

This work must only be performed by authorized service personnel.

## **Maintenance – Every 3000 operating hours**

### **8.12 Every 3000 operating hours**

#### **8.12.1 Checking the fuel injection pump**

This work must only be performed by authorized service personnel.



## 8.13 As required

### 8.13.1 Checking/adjusting the scrapers



**DANGER!**

**Danger to life caused by machine movements!**

- Never step in front of or behind the drums/wheels while the engine is running.

Protective equipment: ■ Working clothes  
 ■ Safety shoes  
 ■ Protective gloves

1. Park the machine safely ↪ *Chapter 6.6 'Parking the machine in secured condition' on page 93.*
2. Check the condition of the eight scrapers (four per drum); clean if necessary.
3. Replace any worn scrapers.

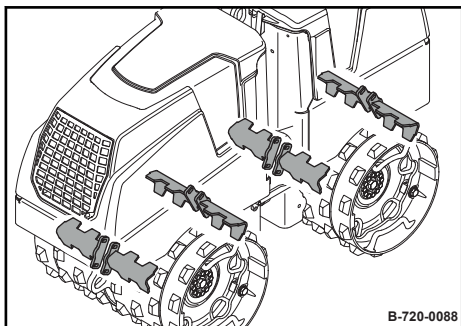

Fig. 181

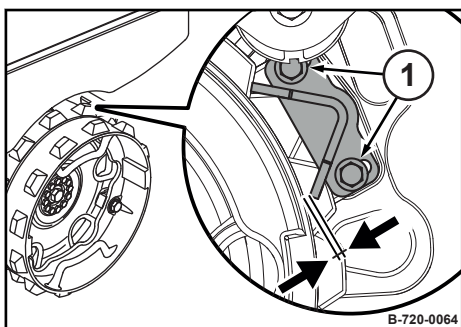

Fig. 182

4. Check the gap between the scrapers and drum.

Nominal value	Approx. 5 mm (0.2 in)
---------------	-----------------------

5. If necessary, loosen the screws (1) and adjust the gap evenly.
6. Tighten the screws.

### 8.13.2 Cleaning the radiator module



**NOTICE!**

**Components may get damaged!**

- Do not bend or damage cooling fins.
- Do not clean with high pressure.

1. Park the machine safely ↪ *Chapter 6.6 'Parking the machine in secured condition' on page 93.*
2. Allow the engine to cool down.

## Maintenance – As required

### Cleaning with compressed air

Protective equipment: ■ Protective gloves  
■ Safety goggles



#### CAUTION!

**Danger of eye injuries caused by particles flying around!**

- Wear your personal protective equipment (safety gloves, protective working clothes, goggles).

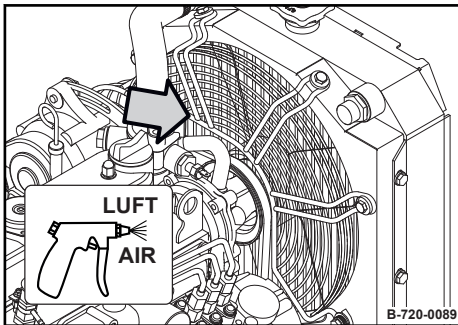

Fig. 183

1. Blow the radiator out with compressed air from inside the engine compartment.
2. Blow the radiator out with compressed air from the outside.

### Cleaning with a cold cleaning agent



#### NOTICE!

**Electric components can be damaged by water entering into the system!**

- Protect electrical equipment such as generator, regulator and starter against the direct water jet.

1. Spray the engine and radiator with a suitable cleaning agent, let it soak in for a while, and then wash off with a strong water jet.
2. Warm up the engine for a while to prevent corrosion.

### 8.13.3 Cleaning the machine

Protective equipment: ■ Working clothes  
■ Safety shoes  
■ Protective gloves

1. Park the machine safely ↪ *Chapter 6.6 'Parking the machine in secured condition' on page 93.*
2. Allow the engine to cool down for at least 30 minutes.

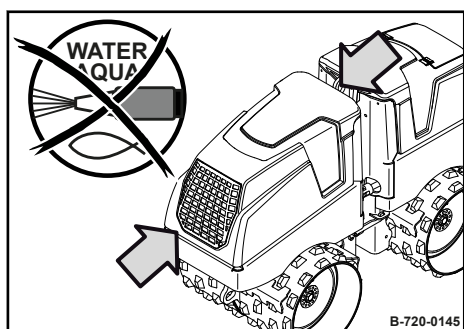

Fig. 184

3.



**NOTICE!**

**Electric components can be damaged by water entering into the system!**

- Do not direct the water jet straight into the cooling air openings, air filter, exhaust outlet or electrical equipment.

Clean the machine from the outside with a water jet.

4.

Warm up the engine for a while to avoid corrosion.

### 8.13.4 Checking the central screw of the drive hub

- Protective equipment:
- Working clothes
  - Safety shoes
  - Protective gloves

1. Park the machine safely ↪ *Chapter 6.6 'Parking the machine in secured condition' on page 93.*
2. Check the tightening torque of the central screw on all four drive hubs.

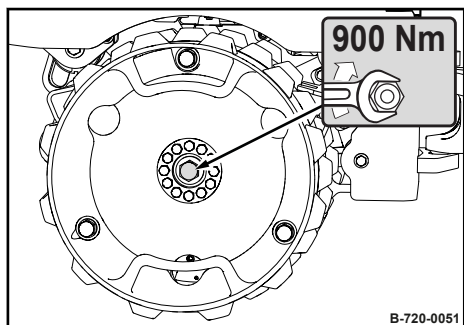

Fig. 185

Nominal value	900 Nm (664 ft·lbf)
---------------	---------------------

### 8.13.5 Cleaning the drum drive / drums



*How dirty the drum drives and drums are depends on the daily operating conditions; clean frequently if necessary.*

*However, perform this maintenance work at the latest after one year.*

Observe the safety notes for lifting the machine ↪ *Chapter 3 'Concerning your safety' on page 19.*

Use lifting tackle which is suitable for the weight of the drums:  
Approx. 102 kg (225 lbs) each.

Always perform maintenance work on the individual drums one at a time.

Protective equipment: ■ Working clothes  
■ Safety shoes  
■ Protective gloves

Prerequisites:

- Adequate space for attaching or removing.
  - The machine is on level, firm ground.
  - If necessary, a second person is present to help remove the drums.
1. Park the machine safely ↪ *Chapter 6.6 'Parking the machine in secured condition' on page 93.*
  2. Engage the articulation lock ↪ *Chapter 8.2.2.1 'Engaging the articulation lock' on page 107.*
  3. If necessary, remove the drum extension ↪ *Chapter 9 'Setting up / refitting' on page 149* and clean it thoroughly.
  4. Attach lifting tackle to the front / rear lashing point.
  5. Lift the machine up and support it safely.

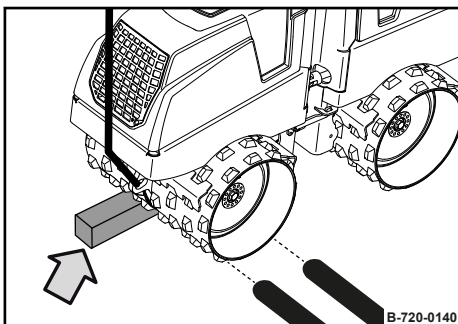

Fig. 186

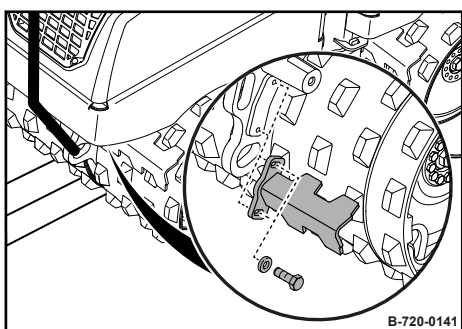

Fig. 187

6. Unscrew the fastening screws and take off the scraper.

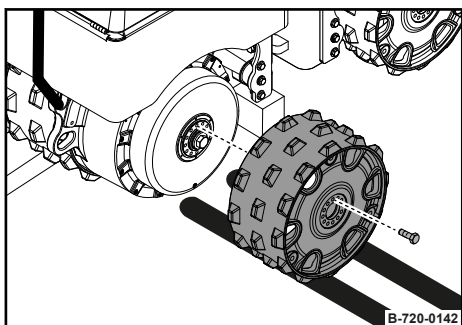

Fig. 188

7. Clean the fastening screws, unscrew them and remove the drum.
8. Clean the drum thoroughly on the inside and outside.
9. Clean the drum drive housing thoroughly.

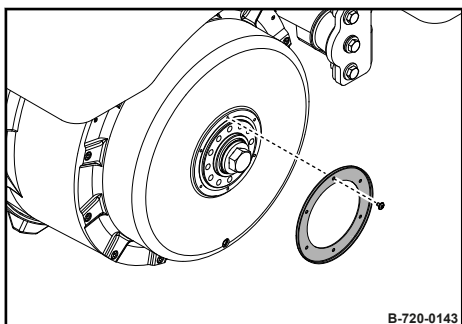

Fig. 189

10. Unscrew the fastening screws and take off the clamping ring.

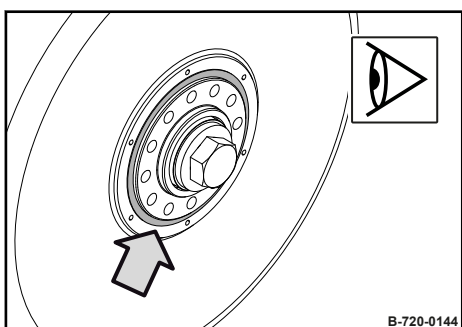

Fig. 190

11. Check the seal ring for wear and damage, change if necessary.
12. Insert and tighten the clamping ring (e.g. spare part no: 009 780 66).
13. Insert the fastening screws with a medium strength retention agent (e.g. spare part no: 009 780 06) into the clamping ring and tighten them.
14. Fasten the drum.

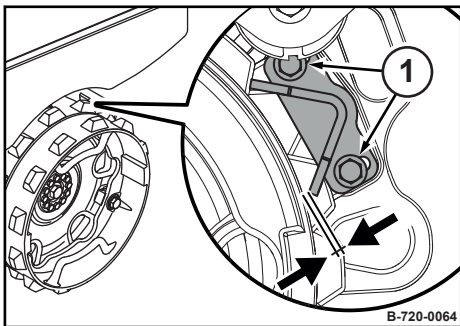

Fig. 191

15. Attach the scraper and insert the fastening screws (1).

16. Set the distance between scraper and drum.

Nominal value	Approx. 5 mm (0.2 in)
---------------	-----------------------

17. Tighten the fastening screws on the scraper.

18. If necessary, reinstall the drum extension ↗ *Chapter 9 'Setting up / refitting' on page 149.*

19. Lower the machine.

20. Repeat the maintenance work for the three other drums one at a time.

21. If necessary, dispose of the seal rings in an environmentally friendly way.

### 8.13.6 Measures prior to extended shut-down period

#### 8.13.6.1 Measures before shutting down

If the machine is shut down for a longer period of time, e.g. winter season, the following work must be carried out:

1. Clean the machine thoroughly.
2. After shutting down store the machine under cover in a dry and well ventilated room.
3. Grease the bare piston rods of all hydraulic cylinders well and pull them in as far as possible.
4. Spray a thin oil film onto to all lever joints and bearing points without lubrication.
5. Repair damaged paint; preserve bare areas thoroughly with anti-corrosive agent.
6. Clean the water separator.
7. Fill the fuel tank with diesel fuel to prevent the formation of condensation water in the tank.
8. Change engine oil and oil filter if the oil has been changed more than 300 hours ago, or if the oil is older than 12 months.
9. Check the anti-freeze concentration and the coolant level.
10. Disconnect the ground strap from the battery (this avoids self-discharge caused by closed-circuit consuming devices).

### 8.13.6.2 Battery service during prolonged machine downtimes



#### **WARNING!**

**Danger of injury caused by exploding gas mixture!**

- Remove the plugs before starting to recharge the battery.
- Ensure adequate ventilation.
- Smoking and open fire is prohibited!
- Do not lay any tools or other metal objects on the battery.
- Do not wear jewellery (watch, bracelets, etc.) when working on the battery.
- Wear your personal protective equipment (protective gloves, protective clothing, goggles).

Protective equipment: ■ Working clothes  
■ Protective gloves  
■ Safety goggles

1. Switch off all consuming devices (e.g. ignition, light).
2. Measure the open-circuit voltage of the battery at regular intervals (at least 1 x per month).
  - ⇒ Reference values: 12.6 V = fully charged; 12.3 V = discharged to 50%.
3. Recharge the battery immediately after an open-circuit voltage of 12.25 V or less is reached. Do not perform boost charging.
  - ⇒ The open-circuit voltage of the battery occurs approx. 10 hours after the last charging process or one hour after the last discharge.
4. Switch off the charging current before removing the charging clamps.
5. After each charging process allow the battery to rest for one hour before taking it into service.
6. For standstill periods of more than one month you should always disconnect the battery. Do not forget to perform regular open-circuit voltage measurements.

### 8.13.6.3 Measures before restarting

1. Replace the fuel filter.
2. Replace the air filter.
3. Change engine oil and oil filter.
4. Check the coolant level.
5. Check the charge condition of the batteries, recharge if necessary. Check the battery fluid level before and after charging.

## Maintenance – As required

6. Connect the ground straps to the batteries.
7. Check the function of the electric system.
8. Check cables, hoses and lines for cracks and leaks.
9. Check the service life of hydraulic hoses and replace if necessary.
10. Start the engine and run it for 15 to 30 minutes with idle speed.
11. While the engine is running keep an eye on the gauges for engine oil pressure and coolant temperature.
12. Check the oil levels.
13. Check the function of electric system, steering and brakes.
14. Clean the machine thoroughly.





### 9.1 Drum extension

#### 9.1.1 Preliminary remarks and safety notes

Prerequisites for attaching and removing the drum extension:

- Adequate space for attaching or removing
- The machine is on level, firm ground
- If necessary, a second person is present to help lift the drum extension

#### 9.1.2 Removing the drum extension

**i** Consider the weight of the drum extensions:  
Approx. 28 kg (62 lbs) each

Protective equipment: ■ Working clothes  
■ Safety shoes  
■ Protective gloves

1. Park the machine safely ↪ Chapter 6.6 'Parking the machine in secured condition' on page 93.
2. Unscrew the fastening bolts (1).
3. Remove the washers.
4. Remove the drum extension (2).

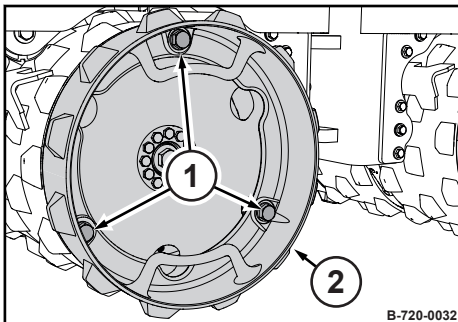

Fig. 192

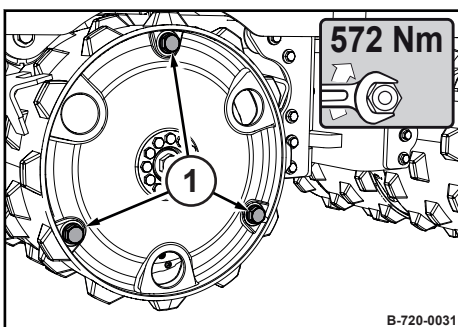

Fig. 193

5. To protect the threads, remount the fastening bolts (1) and washers; tightening torque: 572 Nm (422 ft-lbf).

### 9.1.3 Attaching the drum extension

Protective equipment: ■ Working clothes  
■ Safety shoes  
■ Protective gloves

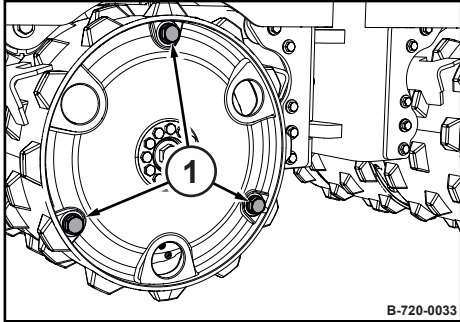

Fig. 194

1. Unscrew the fastening bolts (1) and remove the washers.

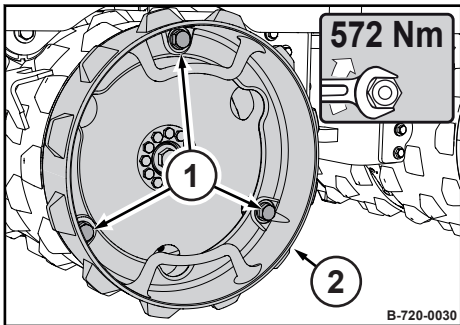

Fig. 195

2. Remount the drum extension (2) with the fastening bolts (1) and washers; tightening torque: 572 Nm (422 ft·lbf).

### 9.2 Teaching the BOSS safety field system

After replacing components in the radio communication system (e.g. radio remote control, radio receiver) or BOSS safety field system (e.g. aerial at the front or back), the BOSS safety field system will need to be retaught.

Prerequisites:

- Main battery switch is switched on
- Emergency stop switch is unlocked

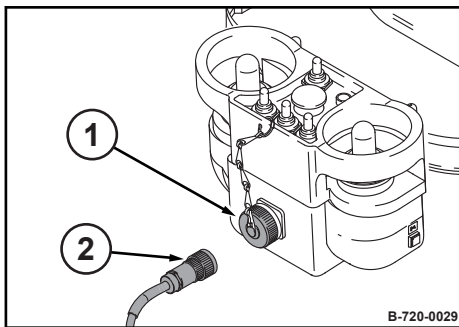

Fig. 196

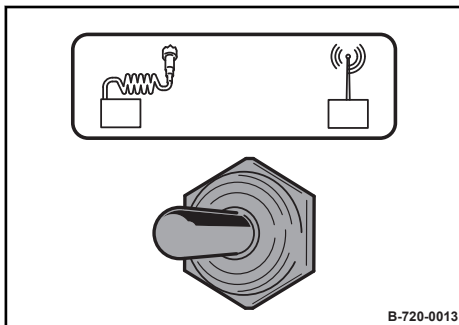

Fig. 197

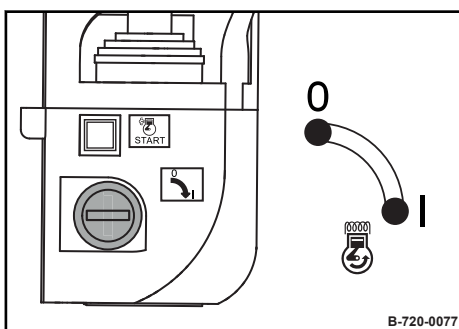

Fig. 198

1. Remove the safety cap (1) and connect the cable (2) to the remote control.

2. Take up position in the safety field at the machine.

⇒ **Distance:** < 1.2 m (1.3 yd).

3. Turn the toggle switch for operating mode to the "left" position.

4. Turn the ignition key to position "I".

## Setting up / refitting – Teaching the BOSS safety field system

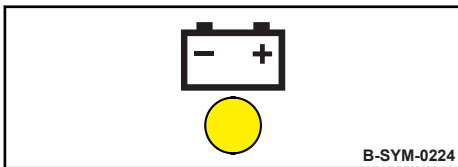

Fig. 199

⇒ The charge control light lights up.

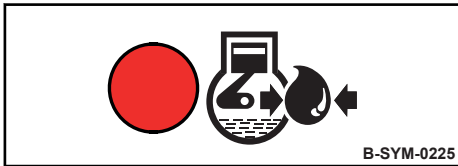

Fig. 200

The engine oil pressure warning light lights up.



Fig. 201

The safety device warning light lights up.

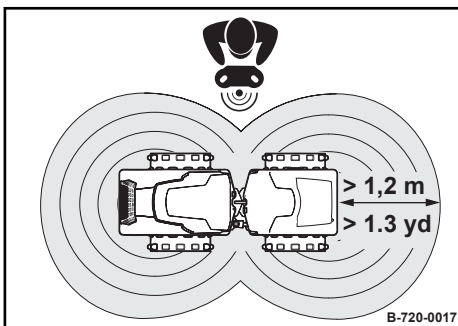

Fig. 202

5. Leave the safety field with the remote control.

⇒ **Distance:** > 1.2 m (1.3 yd).



Fig. 203

The safety device warning light goes out after approx. 2 seconds.

The machine is now ready for operation.





### 10.1 Starting the engine with jump leads



#### NOTICE!

**A wrong connection will cause severe damage in the electric system.**

- Bridge the machine only with a 12 Volt auxiliary battery.

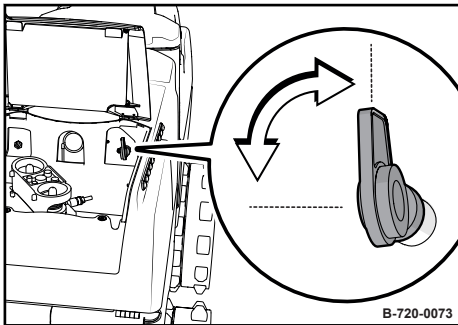

Fig. 204

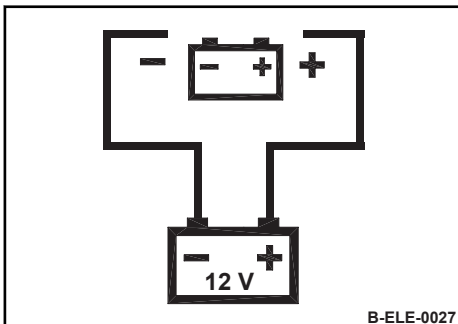

Fig. 205

1. Open the rear protective hood.
2. Switch on the main battery switch.
3. First connect the plus pole of the external battery to the plus pole of the starter battery using the first jump lead.
4. Next, connect the second jump lead to the minus pole of the energizing external battery and then to the minus pole of the starter battery.
5. Start the engine: ↪ *Chapter 6.2.4 'Starting the engine' on page 83.*
6. After starting, disconnect the minus poles first and the plus poles after.
7. Close the rear protective hood.



### 10.2 Switching off the machine manually

**i** If the remote control malfunctions, the engine can be switched off manually.

1. If possible, move the machine onto level, firm ground.
2. Set the travel lever to “middle” position to stop the machine.

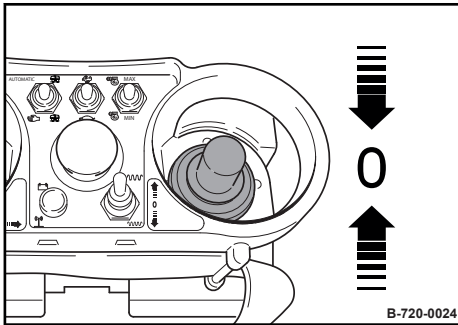

Fig. 206



#### NOTICE!

#### Danger of engine damage!

- Do not shut down the engine all of a sudden from full load speed, but let it idle for about two minutes.

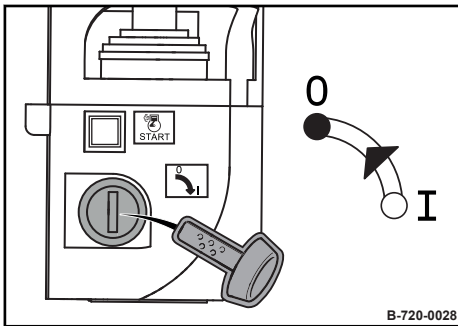

Fig. 207

3. Turn the ignition key to position “0” and pull it out.
4. Open the front protective hood.

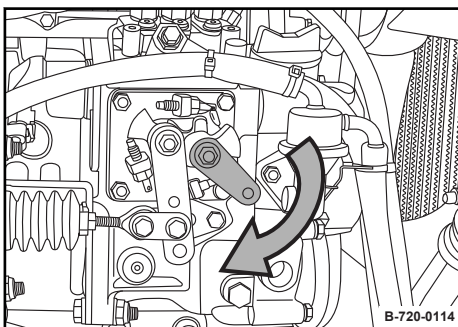

Fig. 208

5. Move the lever on the engine and hold.  
⇒ The engine is shut down.
6. Close the front protective hood again.
7. Open the flap.

## Troubleshooting – Switching off the machine manually

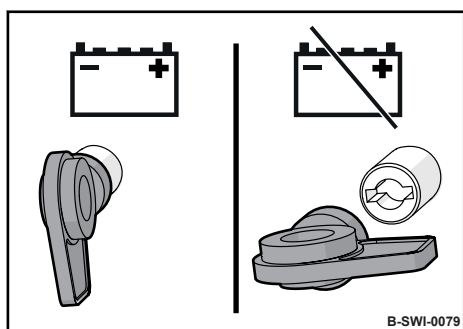

Fig. 209

8. Turn the main battery switch anticlockwise and pull it out.
9. Close the flap again.
10. Shut down the machine and inform our Customer Service Department.
11. Only operate the machine after it has been repaired.

### 10.3 Decrease in the hydraulic oil level

In case of an internal leakage in the hydraulic system, hydraulic oil might collect in the travel system or exciter shaft housing:

- Normally, there must not be any oil in the travel system housing.
- If hydraulic oil collects in the exciter shaft housing, the oil level in it will increase tremendously.

#### Checking the travel system housing

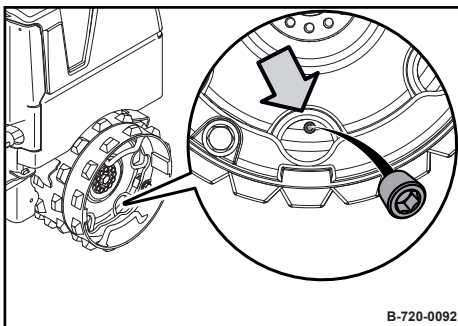

Fig. 210

- Protective equipment:
- Working clothes
  - Safety shoes
  - Protective gloves
  - Safety goggles

1. Move the machine onto flat, level ground so that the oil level inspection plug can be reached through the bottom of the drum.
2. Park the machine safely ↪ *Chapter 6.6 'Parking the machine in secured condition' on page 93.*
3. Place a cleaning cloth underneath the oil level inspection plug and remove the plug.
  - ⇒ Normally, there must not be any oil in the travel system housing.
4. If a significant quantity flows out of the inspection bore you should inform our customer service.
5. Screw the oil level inspection plug back in.
6. If necessary, dispose of the collected oil in line with environmental regulations.

#### Checking the oil level in the exciter shaft housing

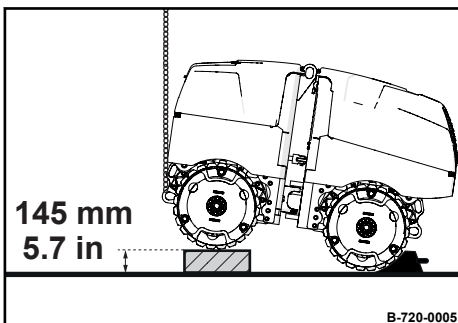

Fig. 211

- Protective equipment:
- Working clothes
  - Safety shoes
  - Protective gloves
  - Safety goggles

1. Park the machine safely ↪ *Chapter 6.6 'Parking the machine in secured condition' on page 93.*
2. Lift the front or rear of the machine 145 mm (5.7 in), support it securely and secure it with a wheel chock.

## Troubleshooting – Decrease in the hydraulic oil level

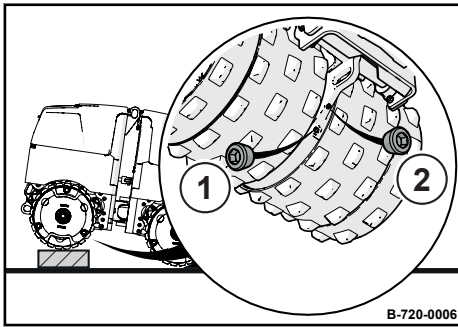

Fig. 212

3. Place a collecting vessel under the drain (1) and ventilation plug (2).
4. Unscrew the drain and ventilation plugs; collect any escaping oil.
  - ⇒ The oil level normally just reaches the bottom edge of the drain bore.
5. If a significant quantity flows out of the drain bore, inform our Customer Service.
6. Screw the drain and ventilation plugs back in.
7. Lower the machine.
8. If necessary, dispose of the collected oil in line with environmental regulations.

### 10.4 Fuse assignment

#### 10.4.1 Notes on safety



**WARNING!**

**Danger of injury by fire in the machine!**

- Do not use fuses with higher ampere ratings and do not bridge fuses.

#### 10.4.2 Fuse box

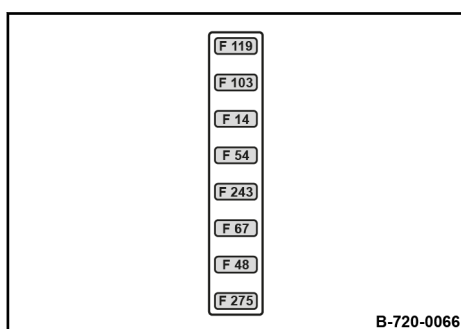

Fig. 213

Fuse	Amperage	Designation
F119	20 A	Fuse for engine
F103	10 A	Fuse for potential 15
F14	25 A	Fuse for engine shut-down solenoid
F54	5 A	Fuse cable remote control
F243	3 A	Fuse for TELEMATIC potential 30
F67	25 A	Fuse control potential 30
F48	30 A	Fuse for pre-heating
F275	5 A	Fuse for ECONOMIZER

## Troubleshooting – Fuse assignment

### 10.4.3 Main fuse

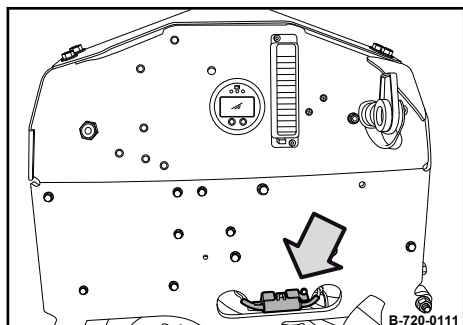

Fig. 214

Fuse	Amperage	Designation
F00	80 A	Main fuse

## 10.5 Engine faults

Fault	Possible cause	Remedy
Engine does not start	Fuel tank empty	Refuel, bleed the fuel system
	Fuel filter clogged, in winter due to paraffin separation	Change the fuel filter, use winter fuel
	Fuel lines leaking	Check all line connections for leaks and tighten the fittings, bleed the fuel system
	Battery not charged or not connected	Tighten the terminal clamps on the battery, check all cable connections
	Starter defective	Have examined by a specialist
	Emergency stop push button is locked	Unlock the emergency stop switch
	Moving parts overheating because of a lack of lubrication	Check the engine oil level, correct if necessary Check the engine oil filter, replace if necessary Have the lubrication system examined by a specialist
Poor starting of engine or engine works irregularly with poor power	Battery power too low, terminal clamps loose or oxidized causing the starter to turn too slowly	Check the battery charge condition, clean the terminal clamps, tighten and cover them with acid-free grease
	Fuel supply too low, fuel system clogged by paraffin separation during winter	Replacing the fuel filter Check all line connections for leaks and tighten the fittings, bleed the fuel system Use winter fuel in winter
	Engine oil with wrong SAE viscosity class	Change the engine oil
	Air filter dirty	Clean, replace if necessary
	Moving parts overheating because of a lack of lubrication	Check the engine oil level, correct if necessary Check the engine oil filter, replace if necessary Check the lubrication system
Excessive exhaust smoke	Engine oil level too high	Check, drain off if necessary
	Insufficient fuel quality	Use specified fuel
	Air filter dirty	Clean, replace if necessary
	Injection valve defective	Have examined by a specialist
Engine overheating, engine must be shut down immediately!	Cooling fins on radiator are extremely dirty (the warning lamp for engine oil temperature lights)	Clean the cooling fins
	Engine oil level too low	Check, fill up if necessary

## Troubleshooting – Engine faults

Fault	Possible cause	Remedy
	Lack of coolant	Check all pipes and hoses for good condition and leak tightness Check the coolant level, top up if necessary Do not use radiator sealant to seal leaks
	Anti-freeze concentration too high	Use coolant with the specified mixing ratio
	Air filter dirty	Clean, replace if necessary
	Thermostat defective	Check the thermostat, replace if necessary
	Interior parts of radiator corroded	Clean or replace the radiator
	Insufficient cooling air supply to the cooling fan	Remove any clogging from the cooling air duct
	Fan, radiator or radiator cap defective	Have examined by a specialist
Engine has insufficient engine oil pressure (engine oil pressure warning lamp lights)	Engine oil level too low	Check, fill up if necessary
	Lubrication system leaking	Have the lubrication system examined by a specialist
The charge control light lights during operation, the warning buzzer sounds	Generator speed too low	Check the generator belt for tension, replace the belt if necessary
	Generator or regulator defective	Have examined by a specialist



## Troubleshooting – Remote control faults (cable operation)

### 10.6 Remote control faults (cable operation)

Fault	Possible cause	Remedy
Engine stops for no reason	Emergency stop switch actuated or defective	Pull out the emergency stop switch Have examined by a specialist; replace if necessary
	Fuse F54, F67 or F103 triggered	Check the fuses; replace if necessary Have examined by a specialist
	Operating mode toggle switch defective	Have examined by a specialist; replace if necessary
	Relay K11 defective	Have examined by a specialist; replace if necessary
	Cable defective	Check cable for tight fit Have examined by a specialist; replace if necessary
	Remote control defective	Have examined by a specialist; replace if necessary
	Cross-slope sensor defective	Check the cross-slope sensor signal, input code 1405 Have examined by a specialist; replace if necessary
	Control defective	Have examined by a specialist; replace if necessary
Ignition key in position "I", display module operative, but engine cannot be started	The travel lever or steering lever is not in neutral position	Disengage the travel lever or steering lever and move to neutral position Check the travel lever signal, input code 2500 Check the steering lever signal, input code 2501
	Fuse F119 triggered	Check the fuses; replace if necessary Have examined by a specialist; replace if necessary
	Battery not charged or defective	Check the battery charge; recharge if necessary Replace defective battery
	Cross-slope sensor defective	Check the cross-slope sensor signal, input code 1405 Have examined by a specialist; replace if necessary
	Relay K39 defective	Check the relay control signal, input code 5070 Have examined by a specialist; replace if necessary

## Troubleshooting – Remote control faults (cable operation)

Fault	Possible cause	Remedy
	Cable defective	Check cable for tight fit Have examined by a specialist; replace if necessary
	Remote control defective	Have examined by a specialist; replace if necessary
	Control defective	Have examined by a specialist; replace if necessary
No function after starting up engine	Start sequence not observed; engine started before horn sounds	Actuate the warning horn button Shut down the engine manually and restart
	Emergency stop switch actuated or defective	Pull out the emergency stop switch Have examined by a specialist; replace if necessary
	Remote control defective	Have examined by a specialist; replace if necessary
	Cable defective	Check cable for tight fit Have examined by a specialist; replace if necessary
	Control defective	Have examined by a specialist; replace if necessary
"CTO" appears on display module when ignition key in position "I"	Cable defective	Check cable for tight fit Have examined by a specialist; replace if necessary
	Control defective	Have examined by a specialist
Engine does not run to full speed	Engine speed toggle switch not actuated or defective	Check the toggle switch position Check the toggle switch signal, input code 2505 Have examined by a specialist; replace if necessary
	Fuse F14 triggered	Check the fuses; replace if necessary Have examined by a specialist; replace if necessary
	Relay K114 defective	Check the relay control signal, input code 5050 Have examined by a specialist; replace if necessary
	Control defective	Have examined by a specialist; replace if necessary
	Cable defective	Check cable for tight fit Have examined by a specialist; replace if necessary

## Troubleshooting – Remote control faults (radio operation)

### 10.7 Remote control faults (radio operation)

Prerequisite:

- Function of the remote control in cable operation without any interference
- No steel rope or metal attachments on the machine (radio connection interference)

Fault	Possible cause	Remedy
Machine does not respond	Aerial defective or wrong one installed	Have examined by a specialist; replace if necessary
	Receiver not or incorrectly connected	Check the plug-in connection between receiver and machine
	Receiver and radio remote control have different system numbers	Check the system numbers; use the radio remote control with identical system number
	Battery empty or defective	Charge or replace the battery
	Distance between machine and radio remote control is too great	Reduce the distance
	Operating mode toggle switch defective	Have examined by a specialist; replace if necessary
	Receiver or radio remote control defective	Have examined by a specialist; replace if necessary
Ignition key in position "I", display module operative, but engine cannot be started	Battery empty or defective	Charge or replace the battery
	Receiver or radio remote control defective	Have examined by a specialist; replace if necessary
Engine stops for no reason	Battery empty or defective	Charge or replace the battery
	Interference caused by other radio signals	Check close vicinity for other radio signals (e.g. airport, construction crane); if necessary, move machine by means of cable operation
	Aerial defective or wrong one installed	Have examined by a specialist; replace if necessary
	Distance between machine and radio remote control is too great	Reduce the distance
	Operating mode toggle switch defective	Have examined by a specialist; replace if necessary
	Emergency stop switch actuated or defective	Pull out the emergency stop switch Have examined by a specialist; replace if necessary

## Troubleshooting – Remote control faults (radio operation)

Fault	Possible cause	Remedy
	Receiver or radio remote control defective	Have examined by a specialist; replace if necessary
	Wiring loom defective	Have examined by a specialist; replace if necessary

### 10.8 Faults in BOSS safety system

Fault	Possible cause	Remedy
No travel movements; steering is still possible	The operator is inside the safety field with radio remote control	Leave the safety field
	Radio remote control or receiver replaced and safety field system subsequently not taught	Teach the safety field system ↪ <i>Chapter 9.2 'Teaching the BOSS safety field system' on page 152</i>
	Front or rear safety device aerial not connected properly or defective	Check the plug-in connection of the aeri-als; replace if necessary
	Distance between machine and radio remote control is too great	Reduce the distance
	Safety device control not connected prop-erly or defective	Check the plug-in connection of the con-trol; replace if necessary
	Radio remote control defective	Have examined by a specialist; replace if necessary
	Wiring loom defective	Have examined by a specialist; replace if necessary

### 10.9 Trouble shooting ECONOMIZER

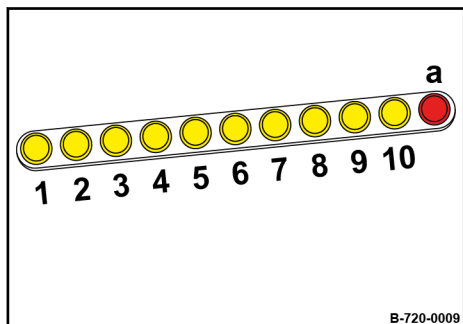

Fig. 215

Fault	Possible cause	Remedy
Status display (a) flashing	Jump operation of the drum on hard ground	
	Vibration frequency and/or engine speed too slow	Make sure the engine reaches maximum speed. Inform our Customer Service.
	Cable breakage	Inform our Customer Service Department
	Sensor has come loose	Inform our Customer Service Department
Status display (a) lights	System error	Restart the ECONOMIZER. Turn the ignition key back to position "0" and then again to position "I". If the status display (a) still does not light up, inform our Customer Service.
LEDs 5, 6 and 7 are flashing	No calibration value available This value is required to calculate the measuring values.	Inform our Customer Service Department
The displayed measuring values are not plausible	Weak spots may also be located under the layer to be compacted and thus adversely affect compaction of the layers above.	In unfavourable cases, excessively varying material composition can influence the measuring results. On material which is too dry or moist, lower measuring values will be displayed.

### 10.10 Fault code display

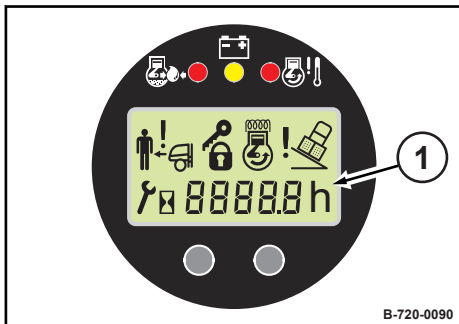

Fig. 216

Faults are displayed on the display module (1) in the form of flashing fault codes. If several faults occur at the same time, these will be indicated by flashing codes, one after the other.

If a fault code is displayed, read out and have the fault rectified by specialists authorised by the operating company. If necessary, contact our Customer Service.

Overview of fault codes ↗ *Chapter 12 'Appendix' on page 177.*

### 10.11 Entering input codes via the display unit



Codes can be entered via the display unit to show operating states and for troubleshooting.

Codes can only be entered when the engine is switched off.

Overview of input codes ↪ Chapter 12 'Appendix' on page 177.

1. Shut down the engine.
2. Turn the ignition key to position "I".

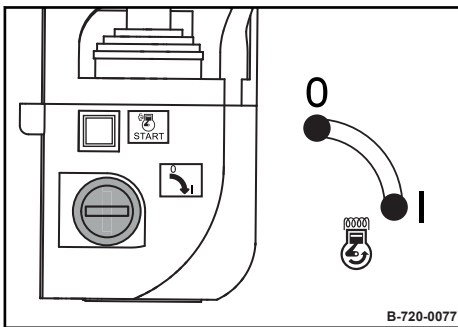

Fig. 217

3. Press function keys F1 and F2 at the same time.  
⇒ The display shows '0000'. The first digit flashes.

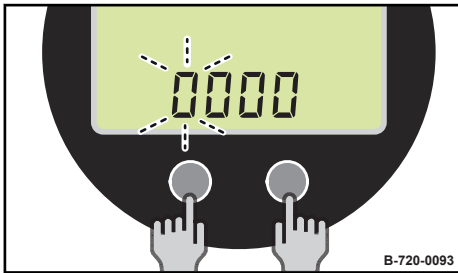

Fig. 218

4. Set the first digit of the input code by pressing function key F1.



Fig. 219



## Troubleshooting – Entering input codes via the display unit

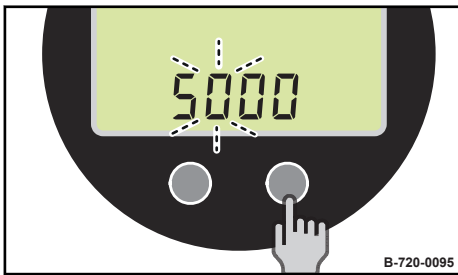

Fig. 220

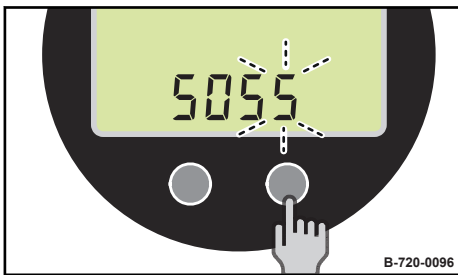

Fig. 221

5. Press function key F2 and move one digit further.
6. Set the other digits of the input code.

7. After setting the fourth digit, end the input by pressing function key F2.  
⇒ The required function is implemented.



*Depending on the function (e.g. switching ECO mode off or on), further codes must be entered ↪ Chapter 12 'Appendix' on page 177.*

8. To terminate the input function, enter the input code '0000' or turn the ignition key to the "0" position.





## Disposal – Final shut-down of machine

### 11.1 Final shut-down of machine

After the machine has reached the end of its service life, the individual components of the machine must be disposed of properly.

Observe national regulations!

Carry out the following work and have the machine dismantled by a state-approved recycling company.



#### **WARNING!**

#### **Health hazard caused by fuels and lubricants!**

- Safety regulations and environmental protection regulations must be followed when handling fuels and lubricants ↪ *Chapter 3.4 'Handling fuels and lubricants' on page 27.*

Protective equipment:

- Working clothes
- Safety shoes
- Protective gloves
- Safety goggles

1. Remove the batteries.
2. Empty the fuel tank.
3. Drain the hydraulic oil tank.
4. Drain the coolant from the cooling system and engine.
5. Drain engine oil from the engine and exciter housing.



## Appendix – List of fault codes

### 12.1 List of fault codes

#### Overview

Fault code	Function group
1000 - 1999	Travel system
2000 - 2499	Steering
2500 - 2999	Remote controls
5000 - 5499	Diesel engine
7000 - 7499	Input codes for machine parameterization
7500 - 7999	Operating hour meter, load spectrum (input codes)
8000 - 8999	Severe software error
9000 - 9998	External IO nodes, joysticks, data collectors (CAN communication and hardware defects )
9999	Unknown fault, displayed value higher than +/- 10000, automatic output by the BMFSA

#### Travel function fault codes

Code	Fault reaction	Fault description	Possible cause	Control terminal	Input code for diagnostics
1030	Output is switched off; function no longer possible	<b>Output valve for forward travel, Y 16</b> Current flowing from this output is too high. Output was switched off!	Excessive current flow in current path, probably caused by a defective coil or short circuit to ground	X3:22	-
1031	Output is switched off; function no longer possible	<b>Output valve for forward travel, Y 16</b> Short circuit current flows out of this output. Output was switched off!	Short circuit to ground in the current path Lines rubbed through Valve defective	X3:22	-
1032	Output is switched off; function no longer possible	<b>Output valve for forward travel, Y 16</b> No or inadequate current flows out of this output.	Wire breakage in current path Current path connected to +12 V	X3:22	1030 1031 1032
1033	Engine is shut down	<b>Output valve for forward travel, Y 16</b> Although the output is switched off, voltage is present.	Current path connected to +12 V	X3:22	1030 1031 1032

## Appendix – List of fault codes

Code	Fault reaction	Fault description	Possible cause	Control terminal	Input code for diagnostics
1040	Output is switched off; function no longer possible	<b>Output valve for reverse travel, Y 17</b> Current flowing from this output is too high. Output was switched off!	Excessive current flow in current path, probably caused by a defective coil or short circuit to ground	X3:24	-
1041	Output is switched off; function no longer possible	<b>Output valve for reverse travel, Y 17</b> Short circuit current flows out of this output. Output was switched off!	Short circuit to ground in the current path Lines rubbed through Valve defective	X3:24	-
1042	Output is switched off; function no longer possible	<b>Output valve for reverse travel, Y 17</b> No or inadequate current flows out of this output.	Wire breakage in current path Current path connected to +12 V	X3:24	1040 1041 1042
1043	Engine is shut down	<b>Output valve for reverse travel, Y 17</b> Although the output is switched off, voltage is present.	Current path connected to +12 V	X3:24	1040 1041 1042
1050	Output is switched off; function no longer possible	<b>Output valve 2. Output, Y 03</b> Current flowing from this output is too high. Output was switched off!	Excessive current flow in current path, probably caused by a defective coil or short circuit to ground	X3:11	-
1051	Output is switched off; function no longer possible	<b>Output valve 2. Output, Y 03</b> Short circuit current flows out of this output. Output was switched off!	Short circuit to ground in the current path Lines rubbed through Valve defective	X3:11	-
1052	Output is switched off; function no longer possible	<b>Output valve 2. Output, Y 03</b> No or inadequate current flows out of this output.	Wire breakage in current path Current path connected to +12 V	X3:11	1050 1051 1052
1053	Output is switched off; engine only runs at idle speed	<b>Output valve 2. Output, Y 03</b> Although the output is switched off, voltage is present.	Current path connected to +12 V	X3:11	1050 1051 1052
1060	Output is switched off; function no longer possible	<b>Brake valve output, Y 04</b> Current flowing from this output is too high. Output was switched off!	Excessive current flow in current path, probably caused by a defective coil or short circuit to ground	X3:40	-

## Appendix – List of fault codes

Code	Fault reaction	Fault description	Possible cause	Control terminal	Input code for diagnostics
1061	Output is switched off; function no longer possible	<b>Brake valve output, Y 04</b> Short circuit current flows out of this output. Output was switched off!	Short circuit to ground in the current path Lines rubbed through Valve defective	X3:40	-
1062	Output is switched off; function no longer possible	<b>Brake valve output, Y 04</b> No or inadequate current flows out of this output.	Wire breakage in current path Current path connected to +12 V	X3:40	1060 1061 1062
1063	Output is switched off; engine only runs at idle speed	<b>Brake valve output, Y 04</b> Although the output is switched off, voltage is present.	Current path connected to +12 V	X3:40	1060 1061 1062
1305	Output is switched off; function no longer possible	<b>Output valve vibration low ampl., Y 56</b> Current flowing from this output is too high. Output was switched off!	Excessive current flow in current path, probably caused by a defective coil or short circuit to ground	X3:12	-
1306	Output is switched off; function no longer possible	<b>Output valve vibration low ampl., Y 56</b> Short circuit current flows out of this output. Output was switched off!	Short circuit to ground in the current path Lines rubbed through Valve defective	X3:12	-
1307	Output is switched off; function no longer possible	<b>Output valve vibration low ampl., Y 56</b> No or inadequate current flows out of this output.	Wire breakage in current path Current path connected to +12 V	X3:12	1305 1306 1307
1308	Output is switched off; engine only runs at idle speed; 2nd gear is inhibited	<b>Output valve vibration low ampl., Y 56</b> Although the output is switched off, voltage is present.	Current path connected to +12 V	X3:12	1305 1306 1307
1310	Output is switched off; function no longer possible	<b>Output valve vibration high ampl., Y 57</b> Current flowing from this output is too high. Output was switched off!	Excessive current flow in current path, probably caused by a defective coil or short circuit to ground	X3:13	-
1311	Output is switched off; function no longer possible	<b>Output valve vibration high ampl., Y 57</b> Short circuit current flows out of this output. Output was switched off!	Short circuit to ground in the current path Lines rubbed through Valve defective	X3:13	-



## Appendix – List of fault codes

Code	Fault reaction	Fault description	Possible cause	Control terminal	Input code for diagnostics
1312	Output is switched off; function no longer possible	<b>Output valve vibration high ampl., Y 57</b> No or inadequate current flows out of this output.	Wire breakage in current path Current path connected to +12 V	X3:13	1310 1311 1312
1313	Output is switched off, engine only runs at idle speed; 2nd gear is inhibited	<b>Output valve vibration high ampl., Y 57</b> Although the output is switched off, voltage is present.	Current path connected to +12 V	X3:13	1310 1311 1312

### Fault codes steering

Code	Fault reaction	Fault description	Possible cause	Control terminal	Input code for diagnostics
2010	Output is switched off; function no longer possible	<b>Output valve steering right, Y 237</b> Current flowing from this output is too high. Output was switched off!	Excessive current flow in current path, probably caused by a defective coil or short circuit to ground	X3:19	1010
2011	Output is switched off; function no longer possible	<b>Output valve steering right, Y 237</b> Short circuit current flows out of this output. Output was switched off!	Short circuit to ground in the current path Lines rubbed through Valve defective	X3:19	-
2012	Output is switched off; function no longer possible	<b>Output valve steering right, Y 237</b> No or inadequate current flows out of this output.	Wire breakage in current path Current path connected to +12 V	X3:19	1010 1011 1012
2013	Engine is shut down	<b>Output valve steering right, Y 237</b> Although the output is switched off, voltage is present.	Current path connected to +12 V	X3:19	1010 1011 1012
2020	Output is switched off; function no longer possible	<b>Output valve steering left, Y 238</b> Current flowing from this output is too high. Output was switched off!	Excessive current flow in current path, probably caused by a defective coil or short circuit to ground	X3:21	-

## Appendix – List of fault codes

Code	Fault reaction	Fault description	Possible cause	Control terminal	Input code for diagnostics
2021	Output is switched off; function no longer possible	<b>Output valve steering left, Y 238</b> Short circuit current flows out of this output. Output was switched off!	Short circuit to ground in the current path Lines rubbed through Valve defective	X3:21	-
2022	Output is switched off; function no longer possible	<b>Output valve steering left, Y 238</b> No or inadequate current flows out of this output.	Wire breakage in current path Current path connected to +12 V	X3:21	1020 1021 1022
2023	Engine is shut down	<b>Output valve steering left, Y 238</b> Although the output is switched off, voltage is present.	Current path connected to +12 V	X3:21	1020 1021 1022

### Fault codes of remote control

Code	Fault reaction	Description of fault	Possible cause
2500	Engine is stopped, all functions are locked, horn sounds	<b>Operation of two remote control system at the same time</b>	A remote control with cable and a wireless remote control are operated at the same time.
2600	Engine stopped, emergency stop relay in the control is switched off, all outputs on control are switched off	<b>Remote control emergency stop</b>	Emergency stop on remote control operated
2601	Engine stopped, emergency stop relay in the control is switched off, all outputs on control are switched off	<b>Fault in data transfer between remote control sender and receiver</b>	Battery empty Radio signal transmission is disturbed Distance between sender and machine too big
2605 <sup>Output of error code 2605 only with software version older than 1.11!</sup>	Engine stopped, emergency stop relay in the control is switched off, all outputs on control are switched off	<b>Receive signal too weak</b>	Radio signal transmission is disturbed Distance between sender and machine too big
2611	Engine is shut down.	<b>CANopen – fault in bus communication</b>	
2612	Engine is shut down.	<b>CANopen – fault in bus communication</b>	
2613	Engine is shut down	<b>CANopen – fault in bus communication</b>	

## Appendix – List of fault codes

### General fault codes for the diesel engine and machine in general

Code	Fault reaction	Fault description	Possible cause	Control terminal	Input code for diagnostics
5015	Only warning, horn sounds, display module is dark,	<b>Potential 15 missing</b> Control has switched relay K11, no voltage	Fuse F 103 defective Relay K11 defective Cable breakage in wiring loom	X3:20	Not possible
5016	Output is switched off; function no longer possible	<b>Battery voltage too low</b> Battery voltage already below 11 Volt when switching on	Battery acid level too low Battery defective Battery discharged		0561
5020	Only warning, horn sounds	<b>Input engine oil pressure, B 06</b> Oil pressure switch delivers the signal "no engine oil pressure"	The oil pressure switch has measured inadequate oil pressure. The engine may be shut down. Should this message be displayed even though the engine is not running, the following faults should be examined:  Current path has short circuit to ground Engine oil level not correct Engine oil pump defective Pressure relief valve after engine oil filter soiled Oil pressure switch defective	X3:03	5020
5021	Engine shut down by inadequate oil pressure	<b>Input engine oil pressure, B 06</b> Fault 5 0 2 0 present longer than 8 seconds Engine is shut down	See fault code 5 0 2 0	X3:03	5020
5025	Engine running	<b>No rotary speed signal from the generator regulator</b> Only warning	Generator regulator defective Line between regulator and control interrupted	X3:41	-
5031	Machine standing	<b>Engine stops, engine stalled</b>	Lack of fuel Engine stopped without a corresponding command from the control		

## Appendix – List of fault codes

Code	Fault reaction	Fault description	Possible cause	Control terminal	Input code for diagnostics
5040	Output is switched off, engine stops	<b>Output HW shutdown solenoid, Y 13</b> Current flowing from this output is too high Output was switched off!	Excessive current flow in current path, probably caused by a defective coil or short circuit to ground	X3:10	-
5041	Output is switched off, engine stops	<b>Output HW shutdown solenoid, Y 13</b> Short circuit current flows out of this output Output was switched off!	Short circuit to ground in the current path Lines rubbed through Valve defective	X3:10	-
5042	Output is switched off, engine stops	<b>Output HW shutdown solenoid, Y 13</b> No or inadequate current flows out of this output.	Wire breakage in current path Current path connected to +12 V	X3:10	5040 5041 5042
5043	Output is switched off, engine stops	<b>Output HW shutdown solenoid, Y 13</b> Although the output is switched off, voltage is present.	Current path connected to +12 V	X3:10	5040 5041 5042
5050	Output is switched off; engine only runs at idle speed	<b>Output relay K 114, speed control solenoid</b> Current flowing from this output is too high. Output was switched off!	Excessive current flow in current path, probably caused by a defective coil or short circuit to ground	X3:09	-
5051	Output is switched off; engine only runs at idle speed	<b>Output relay K 114, speed control solenoid</b> Short circuit current flows out of this output Output was switched off!	Short circuit to ground in the current path Lines rubbed through	X3:09	-
5052	Output is switched off; engine only runs at idle speed	<b>Output HW shutdown solenoid, Y 13</b> No or inadequate current flows out of this output.	Wire breakage in current path Current path connected to +12 V	X3:09	5050 5051 5052
5053	Output is switched off; engine only runs at idle speed	<b>Output relay K 114, speed control solenoid</b> Although the output is switched off, voltage is present.	Current path connected to +12 V	X3:09	5050 5051 5052
5054		<b>Input AUX – signal solenoid Y 13</b>	Wire breakage in current path	X3:04	-

## Appendix – List of fault codes

Code	Fault reaction	Fault description	Possible cause	Control terminal	Input code for diagnostics
5060	Output switched off, no potential 15 on machine, control is working, engine is stopped or cannot be started	<b>Output relay K 11, change-over of potential 15</b> Current flowing from this output is too high Output was switched off!	Excessive current flow in current path, probably caused by a defective coil or short circuit to ground	X3:07	-
5061	Output switched off, no potential 15 on machine, control is working, engine is stopped or cannot be started	<b>Output relay K 11, change-over of potential 15</b> Short circuit current flows out of this output Output was switched off!	Short circuit to ground in the current path Lines rubbed through	X3:07	-
5062	Output switched off, no potential 15 on machine, control is working, engine is stopped or cannot be started	<b>Output relay K 11, change-over of potential 15</b> No or inadequate current flows out of this output.	Wire breakage in current path Current path connected to +12 V	X3:07	5060 5061 5062
5063	Output switched off, no potential 15 on machine, control is working, engine is stopped or cannot be started	<b>Output relay K 11, change-over of potential 15</b> Although the output is switched off, voltage is present.	Current path connected to +12 V	X3:07	5060 5061 5062
5070	Output switched off, engine cannot be started	<b>Output relay K 39, starter</b> Current flowing from this output is too high Output was switched off!	Excessive current flow in current path, probably caused by a defective coil or short circuit to ground	X3:06	-
5071	Output switched off, engine cannot be started	<b>Output relay K 39, starter</b> Short circuit current flows out of this output Output was switched off!	Wire breakage in current path Current path connected to +12 V Lines rubbed through	X3:06	-
5072	Output switched off, engine cannot be started	<b>Output relay K 39, starter</b> No or inadequate current flows out of this output.	Wire breakage in current path Current path connected to +12 V	X3:06	5070 5071 5072

## Appendix – List of fault codes

Code	Fault reaction	Fault description	Possible cause	Control terminal	Input code for diagnostics
5073	All outputs switched off, engine stopped, safety relay switched off	<b>Output relay K 39, starter</b> Although the output is switched off, voltage is present.	Current path connected to +12 V	X3:06	5070 5071 5072
5080 5085	Output switched off, horn cannot sound	<b>Output horn, H 07</b> Current flowing from this output is too high Output was switched off!	Excessive current flow in current path, probably caused by a defective coil or short circuit to ground	X3:08 X3:36	-
5081 5086	Output switched off, horn cannot sound	<b>Output horn, H 07</b> Short circuit current flows out of this output. Output was switched off!	Short circuit to ground in the current path Lines rubbed through Horn defective	X3:08 X3:36	-
5082 5087	Output switched off, horn cannot sound	<b>Output horn, H 07</b> No or inadequate current flows out of this output.	Wire breakage in current path Current path connected to +12 V	X3:08 X3:36	5080 5081 5082
5083 5088	Horn may sound continuously	<b>Output horn, H 07</b> Although the output is switched off, voltage is present.	Current path connected to +12 V	X3:08 X3:36	5080 5081 5082
5090	Machine does not start	<b>Input inclination switch B56</b> The machine cannot be started, because the input does not receive a signal from the inclination switch.	Wire breakage in current path Switch defective The switch is in actuated state (incorrect installation position)	X3:23	1405
5091	Shutdown of diesel engine	<b>Input inclination switch B56</b> The diesel engine is shut down because the input on the control does not receive a signal from the inclination sensor	Wire breakage in current path Switch defective The switch is in actuated state (machine has turned over) The machine must first be shut down after it has been placed in correct position.	X3:23	1405

## Appendix – List of fault codes

Code	Fault reaction	Fault description	Possible cause	Control terminal	Input code for diagnostics
5092	Shutdown of diesel engine	<b>Input inclination switch B56</b> The diesel engine is shut down because the input on the control does not receive a signal from the inclination sensor + Start lock activated	The switch is in actuated state (machine has turned over) + Start lock activated Wire breakage in current path Switch defective	X3:23	1405
5100	Horn sounds; <b>only warning!</b>	<b>Input coolant temperature sensor, B53</b> Coolant temperature too high	Lack of coolant Radiator defective Sensor defective	X3:05	5100
5101	Vibration and 2. gear switched off	<b>Input coolant temperature sensor, B53</b> Coolant temperature too high over a longer period of time	Lack of coolant Radiator defective Sensor defective	X3:05	5100

### Fault in BOSS safety system

Code	Fault reaction	Description of fault	Possible cause
6001	Machine travels for 15min. without activated BOSS safety system. Attention: Only for servicing purposes!	Warning that service mode is active	Service mode activated via input code
6010	Travel movement not possible, only steering	Fault of front safety field antenna (W12)	Wire breakage in current path, front safety field antenna defective
6011	Travel movement not possible, only steering	Fault of rear safety field antenna (W13)	Wire breakage in current path, rear safety field antenna defective
6012	Travel movement not possible, only steering	Transponder fault (no feedback)	Fault in radio link of safety system, transponder of remote control defective
6013	Travel movement not possible, only steering	Transponder fault	Internal fault in transponder of remote control
6014	Travel movement not possible, only steering	Fault in safety field control (A115)	Internal fault in safety field control
6015	Travel movement not possible, only steering	Fault in bus communication between safety field control and transponder	Wire breakage in current path
6016		Reception quality safety field control	

## Appendix – List of fault codes

### Faults in parametrization

Code	Fault reaction	Fault description	Possible cause	Control terminal	Input code for diagnostics
7010	Machine cannot be started; module is not completely initialized	No machine type set	Module is new; parameters were deleted		0725



## 12.2 Input codes for BLM control

### Outputs for travel functions

Fault description	Cause	Remedy
1010	Output valve steering right, Y 237	Display value = output voltage in Volt
	Voltage at output	Display value = output voltage in Volt
1011	Output valve steering right, Y 237	Display value = output current in Amperè
	Current at output	Display value = output current in Amperè
1012	Output valve steering right, Y 237	0000 = Output not triggered 0001 = Output triggered
	Logic level of control	0000 = Output not triggered 0001 = Output triggered
1015	Valve control, steering	0100 = steering to the left 0010 = Valve not triggered 0011 = steering to the right
		0100 = steering to the left 0010 = Valve not triggered 0011 = steering to the right
1020	Output valve steering left, Y 238	Display value = output voltage in Volt
	Voltage at output	Display value = output voltage in Volt
1021	Output valve steering left, Y 238	Display value = output current in Amperè
	Current at output	Display value = output current in Amperè
1022	Output valve steering left, Y 238	0000 = Output not triggered 0001 = Output triggered
	Logic level of control	0000 = Output not triggered 0001 = Output triggered
1030	Output valve travelling forward, Y 16	Display value = output voltage in Volt
	Voltage at output	Display value = output voltage in Volt
1031	Output valve travelling forward, Y 16	Display value = output current in Amperè
	Current at output	Display value = output current in Amperè
1032	Output valve travelling forward, Y 16	0000 = Output not triggered 0001 = Output triggered
	Logic level of control	0000 = Output not triggered 0001 = Output triggered
1035	Valve control, travel system	0100 = Driving forward 0010 = Drum stopped 0011 = Driving reverse

## Appendix – Input codes for BLM control

Fault description	Cause	Remedy
1040	Output valve travelling reverse, Y 17	Display value = output voltage in Volt
	Voltage at output	Display value = output voltage in Volt
1041	Output valve travelling reverse, Y 17	Display value = output current in Amperè
	Current at output	Display value = output current in Amperè
1042	Output valve travelling reverse, Y 17	0000 = Output not triggered 0001 = Output triggered
	Logic level of control	0000 = Output not triggered 0001 = Output triggered
1050	Output valve 2. gear, Y 03	Display value = output voltage in Volt
	Voltage at output	Display value = output voltage in Volt
1051	Output valve 2. gear, Y 03	Display value = output current in Amperè
	Current at output	Display value = output current in Amperè
1052	Output valve 2. gear, Y 03	0000 = Output not triggered 0001 = Output triggered
	Logic level of control	0000 = Output not triggered 0001 = Output triggered
1060	Output brake valve, Y 04	Display value = output voltage in Volt
	Voltage at output	Display value = output voltage in Volt
1061	Output brake valve, Y 04	Display value = output current in Amperè
	Current at output	Display value = output current in Amperè
1062	Output brake valve, Y 04	0000 = Output not triggered 0001 = Output triggered
	Logic level of control	0000 = Output not triggered 0001 = Output triggered

### Outputs for work functions

Fault description	Cause	Remedy
1305	Output valve vibration low amplitude, Y 56	Display value = output voltage in Volt
	Voltage at output	Display value = output voltage in Volt
1306	Output valve vibration low amplitude, Y 56	Display value = output current in Amperè
	Current at output	Display value = output current in Amperè
1307	Output valve vibration low amplitude, Y 56	0000 = Output not triggered 0001 = Output triggered
	Logic level of control	0000 = Output not triggered

## Appendix – Input codes for BLM control

Fault description	Cause	Remedy
1307	Logic level of control	0001 = Output triggered
1310	Output valve vibration high amplitude, Y 57	Display value = output voltage in Volt
	Voltage at output	Display value = output voltage in Volt
1311	Output valve vibration high amplitude, Y 57	Display value = output current in Amperè
	Current at output	Display value = output current in Amperè
1312	Output valve vibration high amplitude, Y 57	0000 = Output not triggered 0001 = Output triggered
	Logic level of control	0000 = Output not triggered 0001 = Output triggered

### Inputs logic and power module

Fault description	Cause	Remedy
1400	Input signal L from generator regulator	12 V > Generator stopped Ground, 0 V > Generator running
1401	Input oil pressure switch, B 06	12 V > No oil pressure Ground, 0 V > Oil pressure
1402	Input limit switch engine speed solenoid, Aux	12 V > Solenoid retracted 0V Ground > Solenoid not in end position
1405	Input inclination sensor, B 56	12 V > Inclination less than 45° 0V Ground > Inclination higher than 45°
1409	Activation input, cable remote control, S 101	12 V > Operating mode cable remote control
1410	Activation input, radio remote control, S 101	12 V > Operating mode wireless

### Diesel engine, machine electrics

Fault description	Cause	Remedy
5010	Engine speed	Display value = 1/min
5020	Engine oil pressure, B 06	0000 = No engine oil pressure 0001 = Engine oil pressure OK
	Shows status of input engine oil pressure	0000 = No engine oil pressure 0001 = Engine oil pressure OK
5030	Inclination sensor, B 56	0000 = No signal, machine inclined more than 45°, or switch defective

## Appendix – Input codes for BLM control

Fault description	Cause	Remedy
5030	Inclination sensor, B 56	0001 = OK, inclination of machine less than 45°
	Shows the switching state of the inclination switch	0000 = No signal, machine inclined more than 45°, or switch defective 0001 = OK, inclination of machine less than 45°
5040	Output via winding of shut-down solenoid, Y 13	Display value = output voltage in Volt
	Voltage at output	Display value = output voltage in Volt
5041	Output via winding of shut-down solenoid, Y 13	Display value = output current in Amperè
	Current at output	Display value = output current in Amperè
5042	Output via winding of shut-down solenoid, Y 13	0000 = Output not triggered 0001 = Output triggered
	Logic level of control	0000 = Output not triggered 0001 = Output triggered
5050	Output relay K 114, engine speed solenoid	Display value = output voltage in Volt
	Voltage at output	Display value = output voltage in Volt
5051	Output relay K 114, engine speed solenoid	Display value = output current in Amperè
	Current at output	Display value = output current in Amperè
5052	Output relay K 114, engine speed solenoid	0000 = Output not triggered 0001 = Output triggered
	Logic level of control	0000 = Output not triggered 0001 = Output triggered
5055	Enable parameter change ECO-mode	
5056	Confirm parameter change ECO-mode	<b>Subsequently switch off the ignition!</b>
5057	ECO-mode off	<b>Enter code number 5055 first!</b>
5058	ECO-mode on	<b>Enter code number 5055 first!</b>
5059	Display of ECO-mode setting	0 = ECO-mode off 1 = ECO-mode on
5060	Output relay K 11, potential changeover	Display value = output voltage in Volt
	Voltage at output	Display value = output voltage in Volt
5061	Output relay K 11, potential changeover	Display value = output current in Amperè

## Appendix – Input codes for BLM control

Fault description	Cause	Remedy
5061	Current at output	Display value = output current in Amperè
5062	Output relay K 11, potential changeover	0000 = Output not triggered 0001 = Output triggered
	Logic level of control	0000 = Output not triggered 0001 = Output triggered
5070	Output relay K 39, starter	Display value = output voltage in Volt
	Voltage at output	Display value = output voltage in Volt
5071	Output relay K 39, starter	Display value = output current in Amperè
	Current at output	Display value = output current in Amperè
5072	Output relay K 39, starter	0000 = Output not triggered 0001 = Output triggered
	Logic level of control	0000 = Output not triggered 0001 = Output triggered
5080	Output horn, H 07	Display value = output voltage in Volt
	Voltage at output	Display value = output voltage in Volt
5081	Output horn, H 07	Display value = output current in Amperè
	Current at output	Display value = output current in Amperè
5082	Output horn, H 07	0000 = Output not triggered 0001 = Output triggered
	Logic level of control	0000 = Output not triggered 0001 = Output triggered
5085	Output 2 horn, H 07	Display value = output voltage in Volt
	Voltage at output	Display value = output voltage in Volt
5086	Output 2 horn, H 07	Display value = output current in Amperè
	Current at output	Display value = output current in Amperè
5087	Output 2 horn, H 07	0000 = Output not triggered 0001 = Output triggered
	Logic level of control	0000 = Output not triggered 0001 = Output triggered
5100	Coolant temperature sensor, B 53	0000 = Temperature too high, excessive temperature 0001 = Temperature OK

## Appendix – Input codes for BLM control

### Checking the function of the remote controls

Fault description	Cause	Remedy
2500	Actuation of travel lever on remote control, S 138	0100 = Travel lever shifted forward 0010 = Travel lever not moved 0001 = Travel lever shifted backward
2501	Actuation of steering joystick on remote control, S 137	0100 = Joystick actuated to the left 0010 = Joystick not moved 0001 = Joystick actuated to the right
2502	Position of switch for vibration, S 36	0100 = Switch operated to forward, vibration high amplitude 0010 = Switch not operated 0001 = Switch operated to reversed, vibration low amplitude
2503	Position of switch for type of vibration, S 132	0100 = Switch operated to forward, automatic operation 0010 = Switch not operated, manual operation
2504	Position of switch for fast speed, S 133	0100 = Switch operated to forward, fast speed selected 0010 = Switch not operated, fast speed disabled
2505	Position of switch for engine speed, S 134	0100 = Switch operated to forward, high engine speed 0010 = Switch not operated, idle speed
2506	Position of button for horn, S 03	0000 = Button not operated 0001 = Button operated



*With the input codes listed above it is possible to check the transfer of the individual switching signals from the remote controls to the central control unit.*

*For this purpose start the machine and subsequently press the horn button to bring the remote control sender in operating mode for this function test.*

*For testing the spiral cable switch the operating mode switch to cable operation, connect the spiral cable to the sender and start the machine.*

*If the engine starts, the spiral cable is OK.*

### System information

Fault description	Cause	Remedy
0555	Software Version	3-digit version number
	Shows the software version number.	3-digit version number

## Appendix – Input codes for BLM control

Fault description	Cause	Remedy
0561	Supply voltage	Display value = voltage in V
	Shows the voltage value	Display value = voltage in V

### Setting the remote control type

Fault description	Cause	Remedy
0660	Switches on function "Set remote control type"	See adjustment instructions
0661	confirms the entered remote control type	See adjustment instructions
0662	Preselect radio remote control, default setting	See adjustment instructions

### Fault log

Fault description	Cause	Remedy
0700	Switch on function „Show stored faults“	See adjustment instructions
0701	Switch off function "Show stored faults"	See adjustment instructions
0710	Delete all stored faults	See adjustment instructions

### BOSS safety system

Fault description	Cause	Remedy
6000	Enable service mode	6000
6001	Service mode active, machine travels for 15min. without activated BOSS safety system. Attention: Only for servicing purposes!	6001 = service mode active
6002	Service mode inactive	

### Reading out the operating hour meter

Fault description	Cause	Remedy
7500	Display of hours, operating hour meter	The full hours are displayed
7501	Display of minutes, operating hour meter	The minute digits of the operating hour meter are displayed

### Setting the machine type

Fault description	Cause	Remedy
7010	Activates "Set machine type" function	See adjustment instructions
7011	Confirms entered machine type	See adjustment instructions

## Appendix – Input codes for BLM control

<b>Fault description</b>	<b>Cause</b>	<b>Remedy</b>
7103	Preselect machine type with hoop guard	See adjustment instructions
7104	Preselect machine type without hoop guard	See adjustment instructions





Head Office/Hauptsitz  
BOMAG  
Hellerwald  
D-56154 Boppard  
Germany  
Telefon: +49 6742 100-0  
Fax: +49 6742 3090  
e-mail: info@bomag.com



BOMAG  
Niederlassung Berlin  
Gewerbestraße 3  
15366 Hoppegarten  
GERMANY  
Tel.: +49 3342 369410  
Fax: +49 3342 369436  
e-mail: nlberlin@bomag.com

BOMAG  
Niederlassung Boppard  
Hellerwald  
56154 Boppard  
GERMANY  
Tel.: +49 6742 100360  
Fax: +49 6742 100392  
e-mail: nlboppard@bomag.com

BOMAG  
Niederlassung Chemnitz  
Querstraße 6  
09247 Chemnitz  
GERMANY  
Tel.: +49 3722 51590  
Fax: +49 3722 515951  
e-mail: nlchemnitz@bomag.com

BOMAG  
Niederlassung Hannover  
Dieselstraße 44  
30827 Garbsen-Berenbostel  
GERMANY  
Tel.: +49 5131 70060  
Fax: +49 5131 6766  
e-mail: nlhannover@bomag.com

BOMAG  
Niederlassung München  
Otto-Hahn-Ring 3  
85301 Schweitenkirchen  
GERMANY  
Tel.: +49 8444 91840  
Fax: +49 8444 918420  
e-mail: nlmuenchen@bomag.com

BOMAG  
Niederlassung Stuttgart  
Uferstraße 22  
73630 Remshalden-Grunbach  
GERMANY  
Tel.: +49 7151 986293  
Fax: +49 7151 9862959  
e-mail: nlstuttgart@bomag.com

BOMAG Maschinenhandelsgesellschaft m.b.H.  
Klausenweg 654  
2534 Alland  
AUSTRIA  
Tel.: +43 2258 20202  
Fax: +43 2258 20202-20  
e-mail: austria@bomag.com

BOMAG MARINI EQUIPAMENTOS LTDA  
Rua Comendador Clemente Cifali, 530  
Distrito Industrial Ritter  
Cachoeirinha – RS  
BRAZIL  
ZIP code 94935-225  
Tel.: +55 51 2125-6677  
Fax: +55 51 3470-6220  
e-mail: brasil@bomag.com

BOMAG (CANADA), INC.  
3455 Semenyk Court  
Mississauga, Ontario  
L5C 4P9  
CANADA  
Tel.: +1 905 361 9961  
Fax: +1 905 361 9962  
e-mail: canada@bomag.com

BOMAG (China) Construction  
Machinery Co. , Ltd  
No. 2808, West Huancheng Road,  
Shanghai Comprehensive Industrial  
Zone Fengxian Shanghai 201401  
CHINA  
Tel.: +86 21 3365 5566  
Fax: +86 21 3365 5508  
e-mail: china@bomag.com

BOMAG France S.A.S.  
2, avenue du Général de Gaulle  
91170 VIRY-CHATILLON  
FRANCE  
Tel.: +33 1 69578600  
Fax: +33 1 69962660  
e-mail: france@bomag.com

BOMAG (GREAT BRITAIN), LTD  
Sheldon Way, Larkfield  
Aylesford  
Kent ME20 6SE  
GREAT BRITAIN  
Tel.: +44 1622 716611  
Fax: +44 1622 710233  
e-mail: gb@bomag.com

BOMA Equipment Hong Kong LTD  
Room 1003, 10/F Charm Centre  
700, Castle Peak Road  
Kowloon,  
HONG KONG  
Tel.: +852 2721 6363  
Fax: +852 2721 3212  
e-mail: bomahk@bomag.com

BOMAG Italia Srl.  
Via Roma 50  
48011 Alfonsine  
ITALY  
Tel.: +39 0544 864235  
Fax: +39 0544 864367  
e-mail: italy@bomag.com

FAYAT BOMAG Polska Sp. z.o.o.  
Ul. Szyszkowa 52  
02-285 Warszawa  
POLAND  
Tel.: +48 22 4820400  
Fax: +48 22 4820401  
e-mail: poland@bomag.com

FAYAT BOMAG Rus OOO  
Klyazma block, h 1-g  
141400 Khimki, Moscow region  
RUSSIA  
Tel.: +7 (495) 2879290  
Fax: +7 (495) 2879291  
e-mail: russia@bomag.com

BOMAG GmbH, Singapore  
300, Beach Road  
The Concourse, , 18-06  
Singapore 199555  
SINGAPORE  
Tel.: +65 294 1277  
Fax: +65 294 1377  
e-mail: singapore@bomag.com

BOMAG Americas, Inc.  
125 Blue Granite Parkway  
Ridgeway SC 29130  
U.S.A.  
Tel.: +1 803 3370700  
Fax: +1 803 3370800  
e-mail: usa@bomag.com