

# E-series

Articulated Dump Trucks

B25E | B30E



Blu@dvantage™

**BELL**

# E is for evolution

**Your business is our business. Bell Articulated Dump Trucks haul more, for longer at the lowest cost-per-ton to deliver more on your profit margins.**

As a global leader in Articulated Dump Trucks, Bell Equipment brings you the world class E-series range. The evolutionary E-series is packed with class leading features that deliver production boosting payloads, lower daily operating costs, superior ride quality and uncompromised safety standards. Bell E-series ADTs will give your business the competitive edge you need.



Specifications	B25E	B30E
<b>Gross power</b>	210 kW (282 hp)	240 kW (322 hp)
<b>Operating mass</b>		
Empty	18,763 kg (41,365 lb)	19,216 kg (42,365 lb)
Loaded	42,763 kg (94,276 lb)	47,216 kg (104,093 lb)
<b>Rated payload</b>	24,000 kg (52,911 lb)	28,000 kg (61,729 lb)
<b>2:1 heaped capacity</b>	15 m <sup>3</sup> (19,5 yd <sup>3</sup> )	17,5 m <sup>3</sup> (22,9 yd <sup>3</sup> )

Extensive use of high-strength, lightweight materials give these trucks the best payload-to-mass ratios and hauling efficiencies in each class.

With their oscillating frame and high-floatation tyres, Bell trucks won't leave you stuck on muddy, rutted or hilly terrain.

The redesigned sound-suppressed cab features fatigue-beating controls, advanced diagnostic monitor and a sealed-switch module for convenient, fingertip operation of numerous functions.

Fuel-efficient emission-certified engines deliver clean power without compromise in all conditions. Leading-edge emissions technology ensures rapid engine response and dependable cold-start performance.



**The new E-series range takes ADT functionality to new industry standards, with customer-focused enhancements and the highest level of automated machine protection available.**

Through substantial investments in Research and Development and employing industry leading technology, advancements have been made in the key areas of performance and fuel efficiency – helping you to move more material at lower operating costs and environmental impact.

# Building on pedigree

Building on from the D-series platform, Bell Equipment's evolutionary approach to design delivers optimised power-to-weight ratio and legendary fuel efficiency.

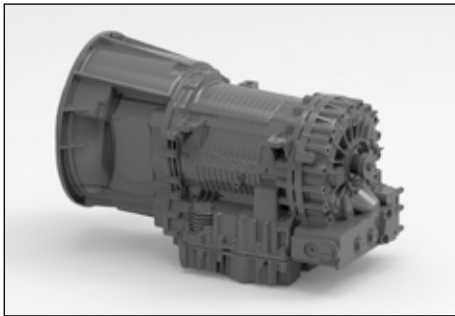

Planetary powershift transmission optimises shift points to match conditions and vehicle weight while protecting the transmission from operator error and abuse.



The transfer case inter-axle differential delivers equal torque to each axle when traction is favourable. When conditions deteriorate, the diff-lock automatically engages to deliver torque to the tyres that can best use it.



High-strength steel and widely spaced taper roller bearings in the articulation area enhance long-term durability.



A tailgate is available as an option for better material retention. The tailgate opens as the bin is raised for dumping. Spring steel straps maintain positive seal throughout the haul, ensuring minimal material is lost.



• Limited-slip differentials and automatic transfer case diff-lock provide real Automatic Traction Control.

• The best-in-class payload-to-weight ratio means that more of your fuel cost is spent moving the material, not running the machine, decreasing your cost per tonne.

• An industry leading, fully automatic six-speed planetary transmission with torque converter lock-up maximises fuel efficiency.

• Automatic retardation slows the truck when the operator backs off the accelerator pedal for more confidence on steep grades and enhanced brake life.

• Electronic unit injection fuel system provides high injection pressures even at low engine speed for improved cold-starting ability, low-speed response, and reduced emissions.

• The short front end provides the best approach angle that allows these ADTs to attack steep terrain.

• High-travel suspension keeps all tyres in constant contact with the ground, for optimum traction.

# gree

Improved payloads, faster haul cycles and industry leading fuel economy all help you move more material at a lower-cost-per-tonne than your competitors.

Class leading payload-to-weight ratio means that more of your fuel cost is spent moving the material and not running the machine - for maximum productivity and profitability.

With a high oscillating frame joint, articulated steering, and high-floatation tyres, these hard working haulers won't let wet weather or steep grades dampen your plans.



**Our innovative comfort ride option is available as an option to even further enhance ride comfort by ensuring minimal whole body vibration exposure.**

Productivity increases, through increased cycle times, and reduced haul road maintenance are even further benefits of the simple, but extremely successful system. Long haul cycles with rough, hard roads will see maximum benefit, especially on the unladen run.

# Uncompromised durability

**Built smarter, to work harder. Bell ADTs offer optimised machine weights so you spend more time and money moving material and not running the machine.**

With decades of ADT experience, the new Bell E-series articulated hauler is designed and manufactured using purpose built, reliable Bell components best suited for the toughest of conditions. The central oscillation joint, high suspension travel on all axles, and balanced weight distribution provide the agility and ability to navigate hostile terrain.



The high-strength steel chassis delivers strength and rigidity without excess weight.



For comfortable productivity, front-suspension damping helps minimise vibration, while a superior suspension seat reduces the roll often experienced in off-road conditions.



Rough terrain demands tough suspensions. Heavy-duty components absorb shocks and come back for more. You get best-in-class ground clearance, too.



Hydraulically actuated dry-disc brakes deliver consistent “on-the-mark” braking, even in cold weather. Simplified design makes them easy to maintain.

Fully enclosed, dual circuit wet disc brakes offer superior braking performance and extended service life essential for wet and muddy conditions. Oil-immersed wet-disc brakes are virtually maintenance-free.

Viscous direct-drive engine fans provide cooling for the best efficiency.

Class leading engine braking coupled with automated transmission retardation, provides superior braking power and reduces service brake wear.

**Other uptime-boosting features include world class on-board diagnostics with live stream functionality, solid-state sealed switches and satellite fleet management system.**

High-strength welded-alloy steel chassis and reinforced articulation joints, offer superior strength and durability with optimised weight for class leading power-to-weight ratio. Lower machine mass reduces powertrain and structural stress.

# Tomorrow's tech today

**Blu@dvantage™ is not only healthy for the environment, it's healthy for your wallet too.**

An efficiently tuned engine combined with a complete weight optimised machine package ensures that Bell ADTs have a minimal carbon footprint. Diesel exhaust fluid (Adblue™) is injected into the flow of the exhaust gases and urea reacts with the NOx gases in the catalytic convertor to form harmless Nitrogen and water.

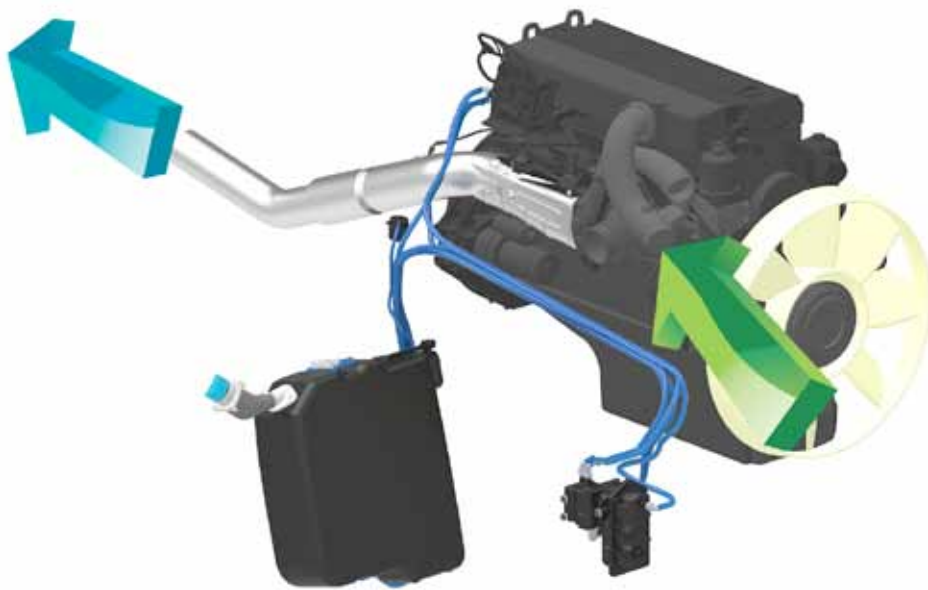

## Blu@dvantage™

- Reduced emissions
- Improved engine efficiency
- Lower fuel consumption
- Improved power
- Improved torque
- Improved engine response



# nnology

- Blu@dvantage™ emissions control coupled with the lowest fuel burn ensures the lowest environmental impact.

- Field tests on the new Blu@dvantage™ system show up to 15% saving in fuel with only a 3-5% usage of urea.



**The all-new truck platform has been specifically engineered to handle future emission requirements and take ADT innovation into the next era.**

Bell Equipment's evolutionary E-series runs "Blu@dvantage™" SCR-technology (Selective Catalytic Reduction) – an industry leading standard in fuel-efficient emission control, designed specifically for the off-highway market to be compliant to Stage IIIB and Tier 4i. Engine power and fuel consumption have been further optimised through event dependant software that controls retardation, cooling and charging of accumulators.

# Operate with ease

**Using the latest in automotive technology and state-of-the-art tooling, the E-series takes operator experience to new heights.**

Climb into the cab of a Bell ADT and you will feel right at home. Its quiet, spacious interior, ergonomically positioned operator station and climate-controlled cabin is loaded with productivity-boosting comfort and convenience features that minimise operator fatigue and enhance the operator's experience. Modern flowing lines, in keeping with current styling trends on road vehicles, offer unsurpassed levels of visibility.

From the state-of-the-art 10" full colour screen and automotive mouse interface with centrally located sealed display unit to air suspension seat, tilt/telescoping steering wheel and optional CD player with high-output speakers, the E-series provides everything your operators need to perform at their best.



Easy-to-understand instruments and intuitive controls wrap around the operator so they're easier to view and operate.



A user friendly 10" colour monitor offers vital operating information, safety warnings, detailed diagnostic readings and dump body function settings.



An automotive controller with menu navigation provides for simple operation of machine functions.



Convenient sealed switch module provides fingertip control of numerous productivity enhancing functions including: **Keyless Start, I-Tip, Dump Body Upper Limit, Soft Stop/Hard Stop Selection, Retarder Aggressiveness and Speed Control.**

- The standard sound-suppression package significantly reduces noise levels and operator fatigue.
- The adaptive transmission control adjusts clutch engagement to ensure smooth, consistent shifts throughout the life of the truck.
- A fully adjustable air-suspension seat with variable damping, auto height adjust according to operator weight, pneumatic lumbar support and multipoint harness for class-leading comfort and safety.
- A purpose designed HVAC climate-control system with automotive-style louvres keeps the glass clear and the cab comfortable.
- New machine styling and cabin design improvements, which include full glass access door and high visibility mirror package, provide exceptional all-round visibility.
- You won't find retarder pedals or levers in a Bell truck. Retarder aggressiveness is simply set on the switch pad. Everything else is automatic.

# Safety, our business too

By listening to users and delivering on expectations in an ever changing workplace, we provide a truck that leads in application safety with numerous groundbreaking innovations.

Independent features such as Keyless Start, HillAssist, Bin Tip Prevention, Auto Park Application (APA), Standard Turbo Spin Protection and On-Board Weighing (OBW) are still standard on the E-series. For improved safety and productivity, the E-series has an automatic Inter-axle Differential Lock (IDL) giving the vehicle full Automatic Traction Control.



Our quiet operator cabins are ROPS/FOPS certified with an air suspension operator seat. Both the operator and trainer seat have retractable lap belts with automatically locking retractors.



An optional integrated reverse camera and high visibility mirrors ensure superior all round visibility.



Keyless start, driver identity and access codes ensure no unauthorised operation of your equipment.



- Full handrails (to ISO 2876) can be installed to offer improved safety when performing engine checks.
- The park brake automatically applies when neutral is selected and it is not possible to engage neutral at speed. Torque dependent park brake release (hill assist) ensures no roll back on slopes.
- Best-in-class retarder and engine braking automatically applies when the operator lifts his foot off the accelerator. Retarder aggressiveness can be simply adjusted on the sealed switch module ensuring maximum descent control for all conditions.
- All trucks can be set up to automatically sound the horn when starting or switching between forward and reverse.
- Multiple geofencing in challenging site conditions ensures safe machine operation, such as downhill speed control, geofence speed limits and bin restrictions.



The exclusive on-board weighing option presents the operator with real time information on the payload while the machine is being loaded. A 'speed restriction' mode can also be activated if the machine is significantly overloaded.



The incorporation of a pitch and roll sensor in the vehicle prevents bin operation if the truck is in an unsafe position.



Both operator or site selectable maximum speed control allows the vehicle to automatically decelerate and apply the retarder to prevent onsite speeding.

# Maximise your uptime

The E-series is loaded with features that make it as easy to maintain as it is to operate. Spend less time and expense getting ready for work and more time getting work done.

Easy-to-reach dipsticks, see-through reservoirs, sight gauges and grouped service points make quick work of the daily routine. Quick-change filters, extended engine and hydraulic oil-service intervals lower daily operating costs and provide superior machine uptime. An industry leading 10" colour monitor offers on-board machine diagnostics as well as automated daily service functionality, this coupled with diagnostic test ports help you troubleshoot and make informed maintenance decisions on site.

- Automated daily service checks can be done with ease and comfort from inside the operator station using the 10" colour LCD monitor and sealed display controller.
- The load-sensing hydraulic system was designed with simplicity in mind, while maintaining efficiency. Fewer components for improved reliability and serviceability.
- Extended engine transmission and hydraulic oil-change for increased uptime and lower operating cost.
- Available environmental drains allow quick, no-spill changes.
- Your Bell Service Centre has the parts and backup you need to stay productive and offers a wide variety of preventative maintenance and support programmes to help you control costs.



If something goes wrong, the diagnostic monitor provides service codes and supporting info to help diagnose the problem.



The cab can be tilted in minutes without special tools, for convenient service access to drivetrain components.



An in-cab load centre simplifies fuse replacement. Fewer relays, connectors and harnesses mean higher reliability.



See-through fluid reservoirs and sight gauges let you check fluid levels at a glance.



Easily accessible test ports allow technicians to troubleshoot problems more quickly.



The centralised lube bank places difficult-to-reach nipples within reach. The convenient lube chart helps ensure that nothing gets overlooked.

# Where ever you are...

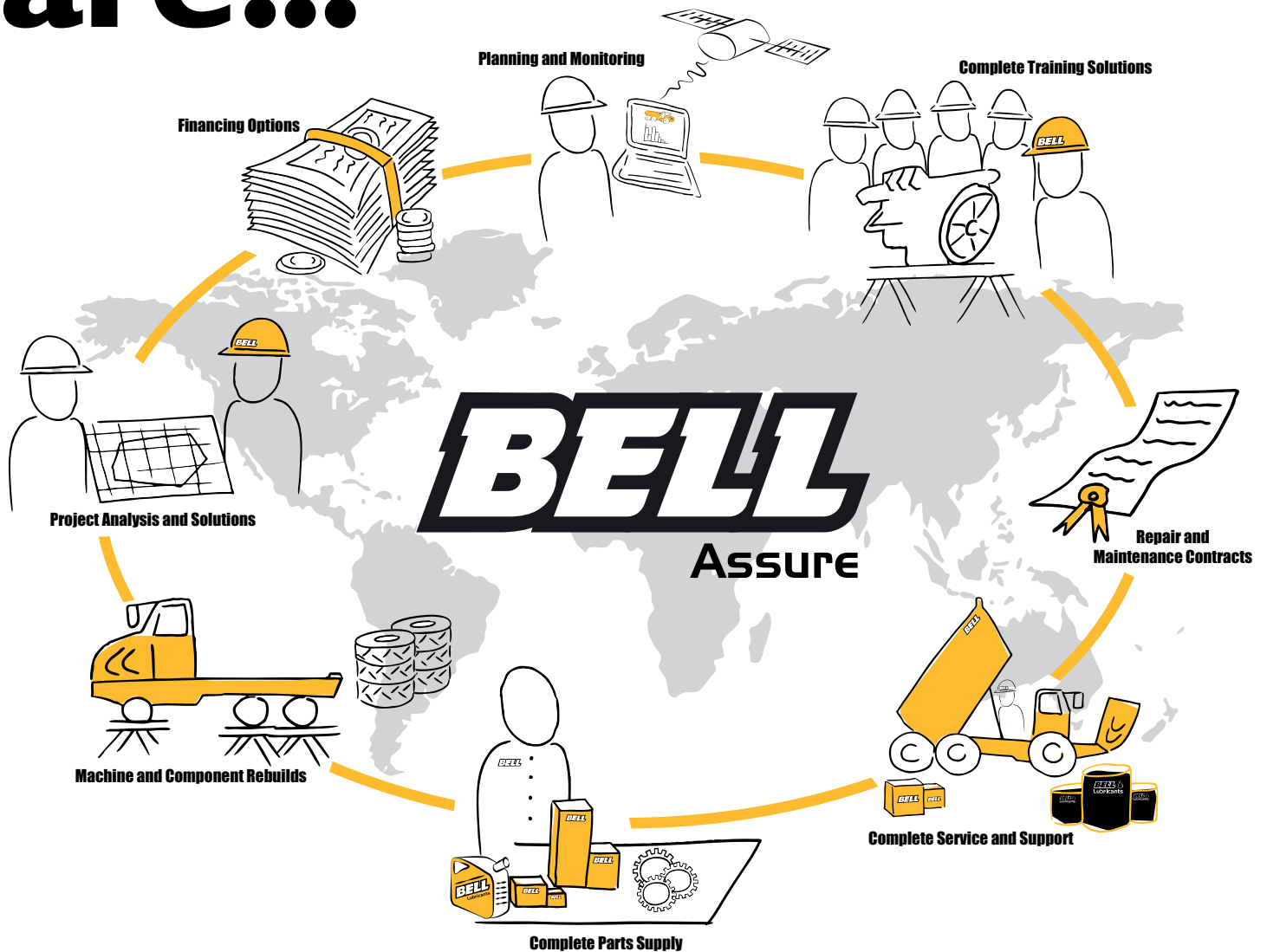

Through our own network as well as approved dealers and strategic alliances we ensure supply and support to the global market.

Develop a lasting and meaningful partnership with Bell Equipment through Bell Assure, your tailor-made support structure furnished with all the after-sales tools you need to give you best value, peace of mind and a unique after-sales experience.

# ...we have you covered



# Smarter fleet management



**BELL**  
Fleetm@tic

**Cutting edge technology, helping you run your fleet smarter. Providing accurate, up-to-date operational data, production data and diagnostic data.**

Machine operational data is processed and compiled into useful production and performance statistics, accessible via the Bell Fleetm@tic website. These reports are also automated and emailed directly to you. The key to a productive and profitable fleet, lies in the ability to monitor and manage your machines and operators efficiently.

## **Fleetm@tic:**

- Maximise productivity
- Generate machine utilisation reports
- Identify operator training requirements
- Pro-active maintenance planning
- Receive machine health data
- Implement safety features
- Protect investments
- Receive real time geospatial data

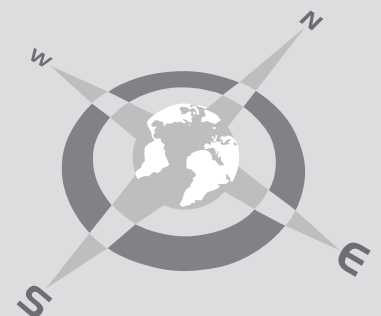

# Technical Data - B25E

## ENGINE

Mercedes Benz OM 926 LA

### Gross Power

210 kW (282 hp) @ 2,200 rpm

### Net Power

203 kW (272 hp) @ 2,200 rpm

### Torque

1,120 Nm (826 lbf) @ 1,200 -1,600 rpm

### Displacement

6,37 litres (388 cu.in)

### Fuel Tank Capacity

379 l (100 US gal)

### Auxiliary Brake

Exhaust brake  
Engine Valve Brake (EVB)

### AdBlue™ Tank Capacity

31 l (8,2 US gal)

### Certification

OM 926 LA meets EU Stage IIIB/EPA Tier 4i emissions regulations.

## TRANSMISSION

Allison 3500PR ORS

### Layout

Engine mounted

### Gear Layout

Constant meshing planetary gears

### Gears

Automatic: 6 Forward, 1 Reverse

### Clutch Type

Hydraulically operated multidisc

### Control Type

Electronic

### Torque Control

Hydrodynamic, with lock-up in all gears.

## TRANSFER BOX

Bell GR 8100

### Layout

Remote mounted

### Gear Layout

Three in-line helical gears

### Output Differential

Interaxle torque proportional, 67/33 Automatic inter axle diff lock.

## AXLES

Bell 15T

Axle housings: fabricated steel  
Differentials: high input limited slip  
Final drive: outboard planetary.

## BRAKING SYSTEM

### Service Brake

Dual circuit, full hydraulic actuation  
Dry disc brakes with 8 calipers (4F, 2M, 2R).

### Maximum Brake Force

184 kN (41,400 lbf) with standard tyres.

### Park & Emergency

Spring applied air released, driveline mounted disc.

### Maximum Brake Force

195 kN (43,900 lbf)

### Auxiliary Brake

Automatic exhaust brake and Engine Valve Brake (EVB).  
Variable Adjustable Hydraulic retarder in transmission.

### Maximum Retardation

539 kW (722 hp)

## WHEELS

### Type

Radial Earthmover

### Tyre

23.5R25

## FRONT SUSPENSION

Semi-independent, leading A-frame supported by hydro-pneumatic suspension struts.

## REAR SUSPENSION

Pivoting walking beams with laminated rubber suspension blocks.

## HYDRAULIC SYSTEM

Variable displacement with load sensing.

### Flow

165 l/min (44 gal/min)

### Pressure

28 MPa (4,061 psi)

### Filter

5 microns

## STEERING SYSTEM

Double-acting steering cylinders with ground driven emergency steering pump.

### Lock to lock turns

4.1

### Steering Angle

45°

## DUMPING SYSTEM

Double-acting, single stage, dump cylinders.

### Raise Time

14,5 s

### Lowering Time

7,5 s

### Tipping Angle

70°

## PNEUMATIC SYSTEM

Air drier with heater and integral unloader valve, serving park brake and auxiliary functions.

### System Pressure

810 kPa (117 psi)

## ELECTRICAL SYSTEM

### Voltage

24 V

### Battery Type

Two AGM (Absorption Glass Mat) type.

### Battery Capacity

2 X 75 Ah

### Alternator Rating

28 V 80 A

## VEHICLE SPEEDS

1st	7 km/h	4 mph
2nd	15 km/h	9 mph
3rd	23 km/h	14 mph
4th	35 km/h	22 mph
5th	47 km/h	29 mph
6th	50 km/h	31 mph
R	7 km/h	4 mph

## CAB

ROPS/FOPS certified

76 dBA internal sound level

measured according to ISO 6396.

# Load Capacity & Ground Pressure

OPERATING WEIGHTS		GROUND PRESSURE				LOAD CAPACITY		OPTION WEIGHTS	
UNLADEN	kg (lb)	LADEN (No sinkage)		LADEN (15% sinkage)		BODY	m <sup>3</sup> (yd <sup>3</sup> )		kg (lb)
Front	9,673 (21,325)	23.5R25	kPa (Psi)	23.5R25	kPa (Psi)	Struck Capacity	12 (15,7)	Bin liner	997 (2,198)
Middle	4,572 (10,080)					SAE 2:1 Capacity	15 (19,5)	Tailgate	735 (1,620)
Rear	4,518 (9,960)	Middle	344 (50)	Middle	221 (32)	SAE 1:1 Capacity	18 (23,5)	Extra wheelset	565 (1,246)
Total	18,763 (41,365)	Rear	344 (50)	Rear	221 (32)	SAE 2:1 Capacity with Autogate	15,5 (20,3)		
<b>LADEN</b>						Rated Payload	24,000 kg		
Front	11,799 (26,012)						(52,911 lbs)		
Middle	15,528 (34,233)								
Rear	15,436 (34,031)								
Total	42,763 (94,276)								

# Dimensions

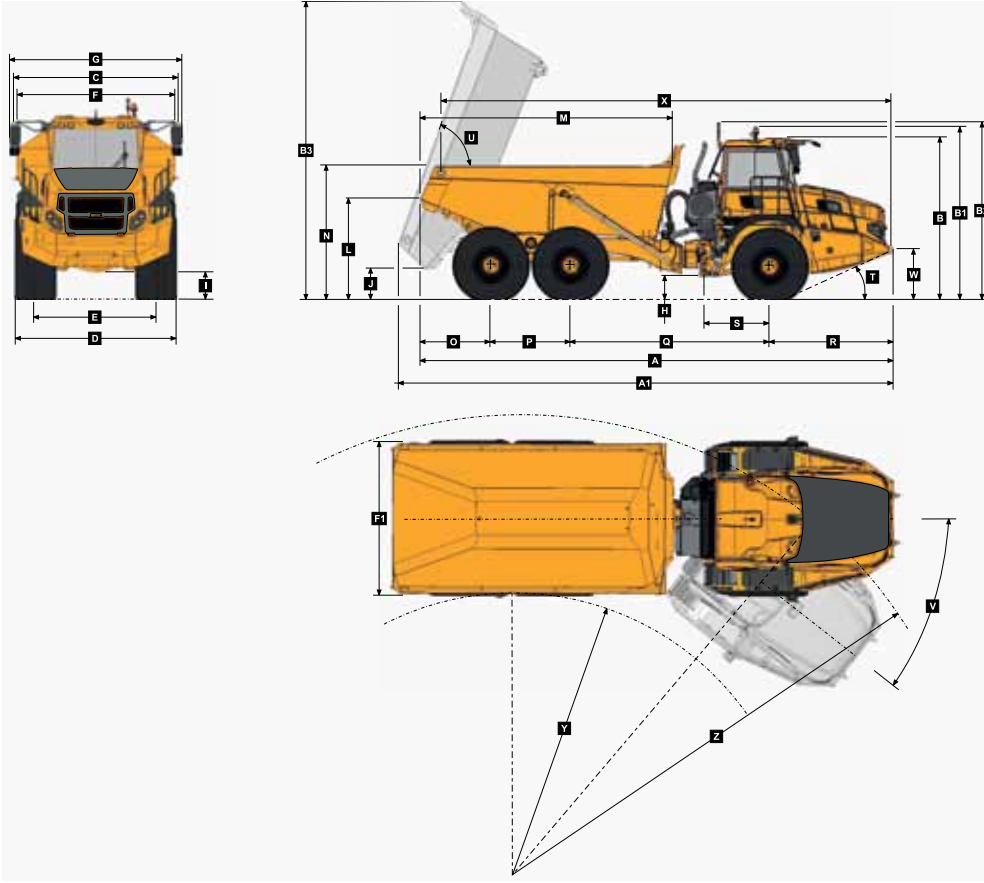

## Machine Dimensions

A	Length - Transport Position	9953 mm
A1	Length - Bin Fully Tipped	10324 mm
B	Height - Transport Position	3426 mm
B1	Height - Rotating Beacon	3661 mm
B2	Height - Load Light	3747 mm
B3	Bin Height - Fully Tipped	6262 mm
C	Width over Mudguards	2985 mm
D	Width over Tyres - 23.5R25	2940 mm
D1	Width over Tyres - 750/65 R25	2998 mm
E	Tyre Track Width - 23.5R25	2356 mm
E1	Tyre Track Width - 750/65 R25	2260 mm
F	Width over Bin	2700 mm
F1	Width over Tailgate	2998 mm
G	Width over Mirrors - Operating Position	3260 mm
H	Ground Clearance - Artic	537 mm
I	Ground Clearance - Front Axle	488 mm
J	Ground Clearance - Bin Fully Tipped	710 mm
K	Ground Clearance - Under Run Bar	N/A
L	Bin Lip Height - Transport Position	2176 mm
M	Bin Length	5272 mm
N	Load over Height	2763 mm
O	Rear Axle Centre to Bin Rear	1500 mm
P	Mid Axle Centre to Rear Axle Centre	1670 mm
Q	Mid Axle Centre to Front Axle Centre	4181 mm
R	Front Axle Centre to Machine Front	2602 mm
S	Front Axle Centre to Artic Centre	1362 mm
T	Approach Angle	25 °
U	Maximum Bin Tip Angle	70 °
V	Maximum Articulation Angle	45 °
W	Front Tie Down Height	1075 mm
X	Machine Lifting Centres	9477 mm
Y	Inner Turning Circle Radius - 23.5R25	4110 mm
Y1	Inner Turning Circle Radius - 750/65 R25	4081 mm
Z	Outer Turning Circle Radius - 23.5R25	8000 mm
Z1	Outer Turning Circle Radius - 750/65 R25	8029 mm

# Gradeability / Rimpull

1. Determine tractive resistance by finding intersection of vehicle mass line and grade line. NOTE: 2% typical rolling resistance is already assumed in chart and grade line.
2. From this intersection, move straight left across charts until line intersects rimpull curve.
3. Read down from this point to determine maximum speed attained at that tractive resistance.

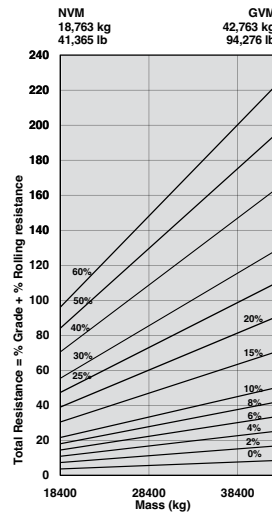

ADT, B25E 6X6 - Tractive Effort

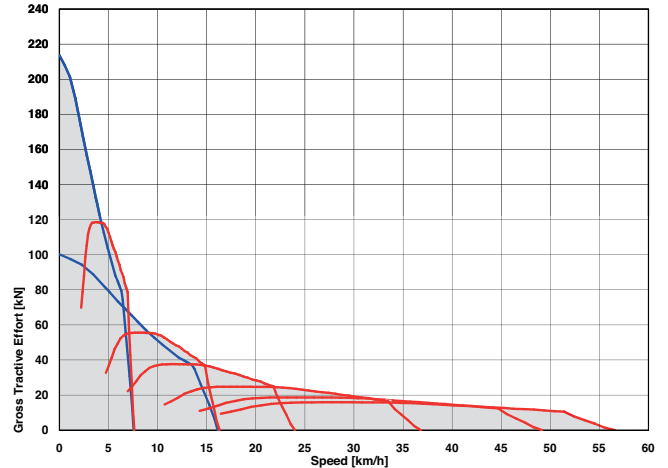

# Retardation

1. Determine retardation force required by finding intersection of vehicle mass line.
2. From this intersection, move straight left across charts until line intersects the curve. NOTE: 2% typical rolling resistance is already assumed in chart.
3. Read down from this point to determine maximum speed.

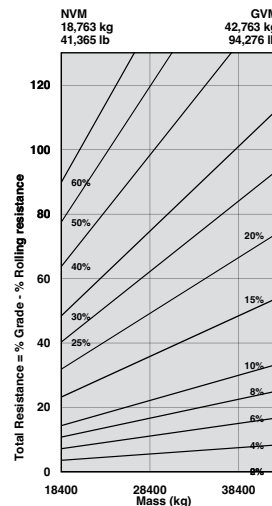

ADT, B25E 6X6 - Retardation

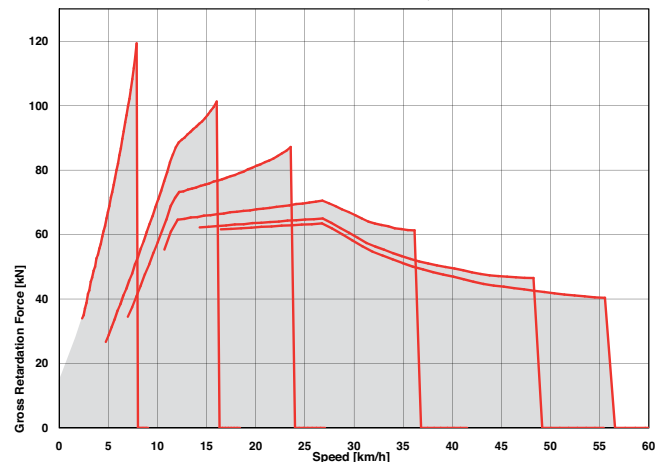

# Technical Data - B30E

## ENGINE

Mercedes Benz OM 926 LA

### Gross Power

240 kW (322 hp) @ 2,200 rpm

### Net Power

232 kW (311 hp) @ 2,200 rpm

### Torque

1,300 Nm (959 lbf) @ 1,200 - 1,600 rpm

### Displacement

7,2 litres (439 cu.in)

### Fuel Tank Capacity

379 l (100 US gal)

### Auxiliary Brake

Exhaust brake  
Engine Valve Brake (EVB)

### AdBlue™ Tank Capacity

31 l (8,2 US gal)

### Certification

OM 926 LA meets EU Stage IIIB/EPA Tier 4i emissions regulations.

## TRANSMISSION

Allison 3500PR ORS

### Layout

Engine mounted

### Gear Layout

Constant meshing planetary gears

### Gears

Automatic: 6 Forward, 1 Reverse

### Clutch Type

Hydraulically operated multidisc

### Control Type

Electronic

### Torque Control

Hydrodynamic, with lock-up in all gears

## TRANSFER BOX

Bell GR 10 000

### Layout

Remote mounted

### Gear Layout

Three in-line helical gears

### Output Differential

Interaxle torque proportional, 67/33 Automatic inter axle diff lock.

## AXLES

Bell 18T

Axle housings: fabricated steel  
Differentials: high input limited slip  
Final drive: outboard planetary.

## BRAKING SYSTEM

### Service Brake

Dual circuit, full hydraulic actuation  
Dry disc brakes with 8 calipers (4F, 2M, 2R).

### Maximum Brake Force

184 kN (41,400 lbf) with standard tyres.

### Park & Emergency

Spring applied air released, driveline mounted disc

### Maximum Brake Force

184 kN (41,400 lbf)

### Auxiliary Brake

Automatic exhaust brake and Engine Valve Brake (EVB).  
Variable Adjustable Hydraulic retarder in transmission.

### Maximum Retardation

554 kW (743 hp)

## WHEELS

### Type

Radial Earthmover

### Tyre

23.5R25 or 750/65R25

## FRONT SUSPENSION

Semi-independent, leading A-frame supported by hydro-pneumatic suspension struts.

## REAR SUSPENSION

Pivoting walking beams with laminated rubber suspension blocks.

## HYDRAULIC SYSTEM

Variable displacement with load sensing.

### Flow

165 l/min (44 gal/min)

### Pressure

28 MPa (4,061 psi)

### Filter

5 microns

## STEERING SYSTEM

Double-acting steering cylinders with ground driven emergency steering pump.

### Lock to lock turns

4.1

### Steering Angle

45°

## DUMPING SYSTEM

Double-acting, single stage, dump cylinders.

### Raise Time

14,5 s

### Lowering Time

7,5 s

### Tipping Angle

70°

## PNEUMATIC SYSTEM

Air drier with heater and integral unloader valve, serving park brake and auxiliary functions.

### System Pressure

810 kPa (117 psi)

## ELECTRICAL SYSTEM

### Voltage

24 V

### Battery Type

Two AGM (Absorption Glass Mat) type

### Battery Capacity

2 X 75 Ah

### Alternator Rating

28 V 80 A

## VEHICLE SPEEDS

1st	7 km/h	4 mph
2nd	15 km/h	9 mph
3rd	23 km/h	14 mph
4th	35 km/h	22 mph
5th	47 km/h	29 mph
6th	50 km/h	31 mph
R	7 km/h	4 mph

## CAB

ROPS/FOPS certified

76 dBA internal sound level

measured according to ISO 6396.

# Load Capacity & Ground Pressure

OPERATING WEIGHTS		GROUND PRESSURE				LOAD CAPACITY		OPTION WEIGHTS	
UNLADEN	kg (lb)	LADEN-No sinkage		LADEN-15% sinkage		BODY	m <sup>3</sup> (yd <sup>3</sup> )		kg (lb)
Front	9,743 (21,480)	23.5R25	kPa (Psi)	23.5R25	kPa (Psi)	Struck Capacity	14 (18,3)	Bin liner	1,124 (2,478)
Middle	4,763 (10,501)					SAE 2:1 Capacity	17,5 (22,9)	Tailgate	785 (1,731)
Rear	4,710 (10,384)	Middle	387 (56)	Middle	248 (36)	SAE 1:1 Capacity	21 (27,5)	Extra wheelset	565 (1,246)
Total	19,216 (42,365)	Rear	387 (56)	Rear	248 (36)	SAE 2:1 Capacity with Autogate	18 (23,5)		
<b>LADEN</b>									
Front	12,751 (28,111)	750/65	kPa (Psi)	750/65	kPa (Psi)	Rated Payload	28,000 kg		
Middle	17,237 (38,001)					Front	229 (33)	Front	149 (22)
Rear	17,228 (37,981)	Middle	316 (46)	Middle	212 (31)		(61,729 lbs)		
Total	47,216 (104,093)	Rear	316 (46)	Rear	212 (31)				

# Dimensions

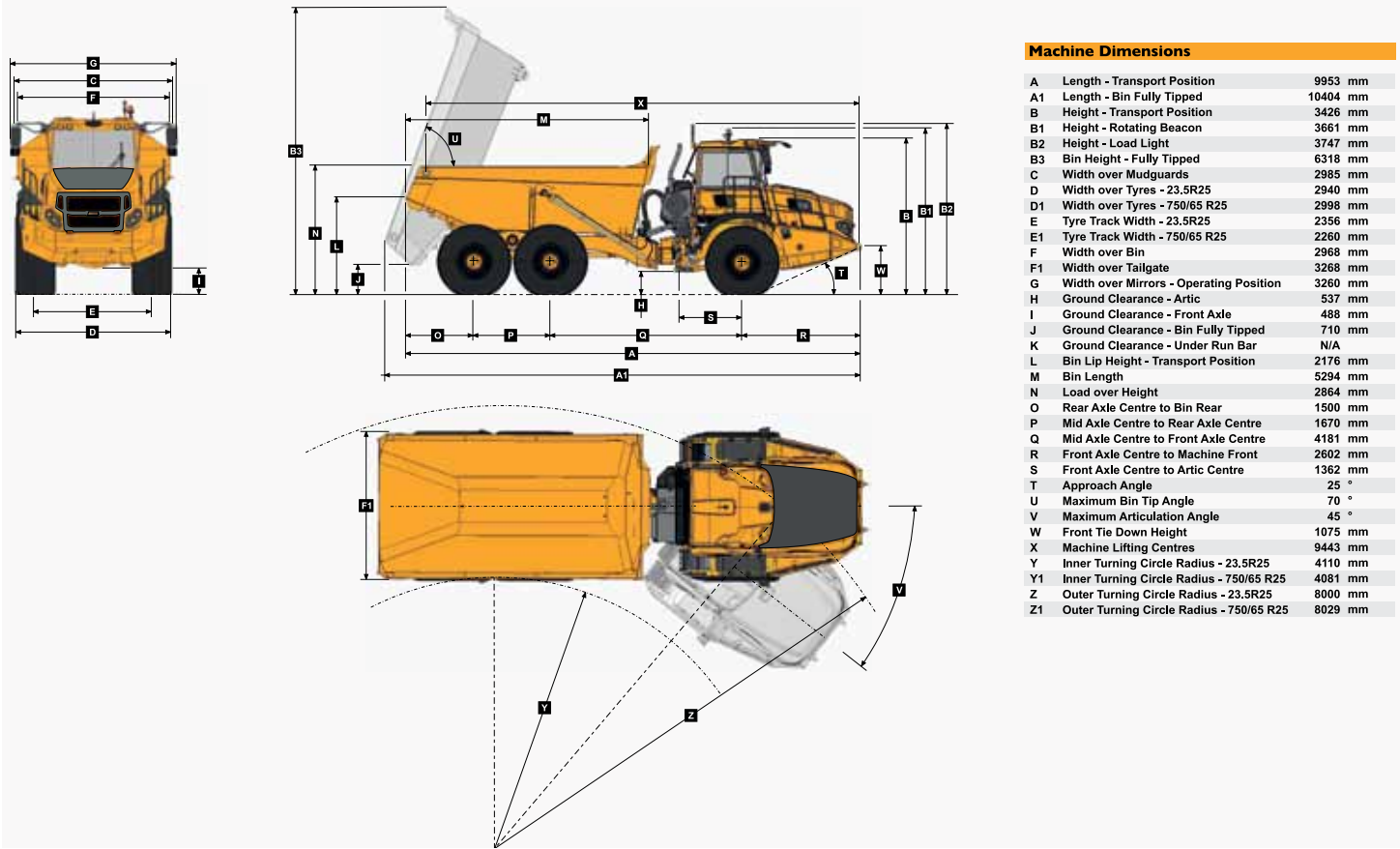

# Gradeability / Rimpull

1. Determine tractive resistance by finding intersection of vehicle mass line and grade line. NOTE: 2% typical rolling resistance is already assumed in chart and grade line.
2. From this intersection, move straight left across charts until line intersects rimpull curve.
3. Read down from this point to determine maximum speed attained at that tractive resistance.

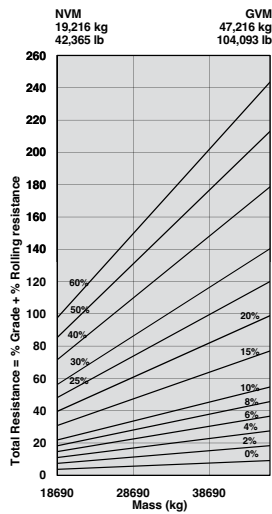

ADT, B30E 6X6 - Tractive Effort

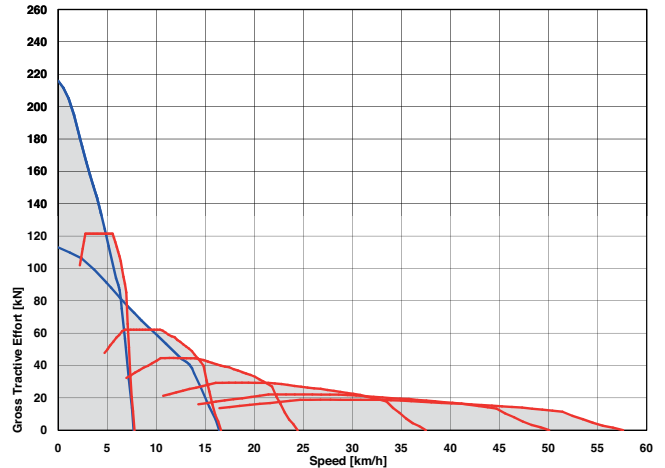

# Retardation

1. Determine retardation force required by finding intersection of vehicle mass line.
2. From this intersection, move straight left across charts until line intersects the curve. NOTE: 2% typical rolling resistance is already assumed in chart.
3. Read down from this point to determine maximum speed.

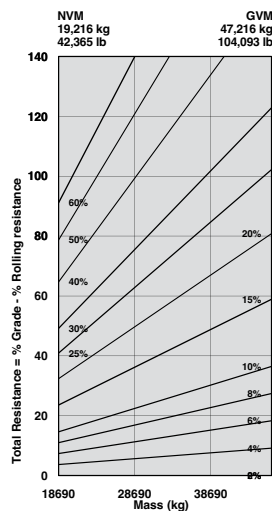

ADT, B30E 6X6 - Retardation

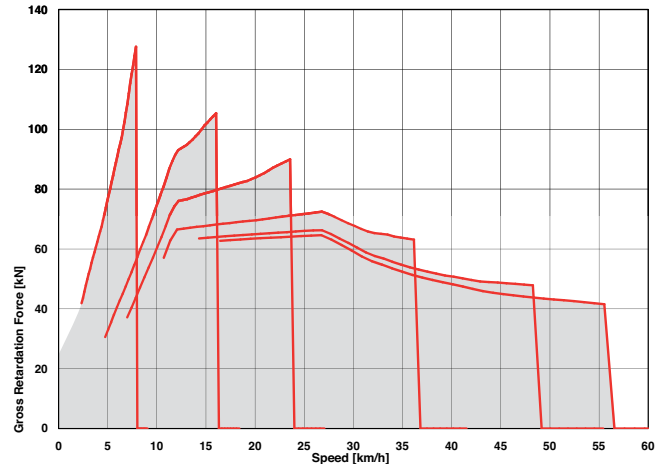

# Features and Options

B25E	B30E	● STANDARD ▲ OPTION
<b>ENGINE</b>		
●	●	Wet-sleeve cylinder liners
●	●	Engine valve brake and exhaust brake
●	●	Dual element air cleaner with dust ejector valve
●	●	Precleaner
●	●	Water separator
●	●	Serpentine drive belt with automatic tensioner
<b>COOLING</b>		
●	●	Crank-shaft mounted viscous-drive fan
●	●	Fan guard
<b>PNEUMATIC SYSTEM</b>		
●	●	Engine-mounted compressor
●	●	Air drier with heater
●	●	Integral unloader valve
<b>ELECTRICAL SYSTEM</b>		
●	●	Battery disconnect
●	●	Drive lights
▲	▲	Deluxe work lights
●	●	Electric Hooter
●	●	Air Horn
●	●	Reverse alarm
●	●	Rotating Beacon
●	●	Pitch Roll Sensor
<b>STEERING SYSTEM</b>		
●	●	Ground-driven secondary steering pump
<b>CAB</b>		
●	●	ROPS/FOPS certification
●	●	Tilt cab
●	●	Gas strut-supported door
●	●	I-Tip programmable dump-body tip settings
●	●	Air conditioner
●	●	Heater
▲	▲	AM/FM radio/CD player
●	●	Rear window guard
●	●	Wiper/washer with intermittent control
●	●	Tilt and telescoping steering wheel
●	●	Centre-mount air-suspension seat
▲	▲	LED work lights
▲	▲	Rotating beacon: seat belt installation
▲	▲	Remote engine and machine isolation
▲	▲	Remote battery jump start

B25E	B30E	● Standard ▲ Option
<b>CAB (continued)</b>		
●	●	Retractable seat belt
●	●	Foldaway trainer seat with retractable seat belt
●	●	12-volt power outlet
●	●	Cup holder
●	●	Cooled/heated lunch box
●	●	Ashtray
▲	▲	Electric adjustable and heated mirrors
●	●	Deluxe 10" colour LCD: Speedometer / Fuel gauge / Transmission oil temperature gauge / Engine coolant temperature gauge / LED function/warning indicators and audible alarm / Transmission gear selection / Tachometer / Battery voltage / Hour meter / Odometer / Fuel consumption / Tip counter / Trip timer / Trip distance / Metric/English units / Service codes/diagnostics
●	●	Backlit sealed switch module functions with: Wiper control / Lights / Heated mirrors / Retarding aggressiveness / Transfer case differential lock / Transmission gear hold / Dump-body tip limit / Automatic dump-body tip settings / Airconditioner/ Heater controls / Preselected Speed Control
<b>DUMP BODY</b>		
●	●	Dump-body mechanical lock
▲	▲	Body liner
▲	▲	Tailgate
▲	▲	Body heater
▲	▲	Less dump body and cylinders
<b>OTHER</b>		
●	●	23.5R25 radial earthmover tyres
●	▲	750/65R25 radial earthmover tyres
●	●	Remote grease banks
▲	▲	Automatic greasing
●	●	Onboard Weighing
▲	▲	Load lights: Stack
▲	▲	Comfort Ride Suspension
▲	▲	Reverse Camera
▲	▲	Hand Rails
●	●	Cab Peak
▲	▲	Lock out kit







All dimensions are shown in millimetres, unless otherwise stated between brackets.  
 Under our policy of continuous improvement, we reserve the right to change technical data  
 and design without prior notice. Photographs featured in this brochure may include optional  
 equipment. Blu@dvantage™ is a trademark of Bell Equipment Co. (PTY) Ltd  
 AdBlue™ is a registered trademark of VDA

**BELL INTERNATIONAL: Tel: +27 (0) 35-907 9431**

**E-mail: [marketing@bellequipment.com](mailto:marketing@bellequipment.com)**

**Web: [www.bellequipment.com](http://www.bellequipment.com)**

 Tel: +61 8-9356-1033

 Tel: +33 (0) 5-55-89-23-56

 Tel: +49 (0) 6631 / 91-13-0

 Tel: +7-495-287-80-02

 Tel: +27 (0) 11-928-9700

 Tel: +34-91-879-60-19

 Tel: +44 (0) 1283-712862

 Tel: +1-855-494-2355

**Strong Reliable Machines  
 Strong Reliable Support**

**BELL**